

152 263

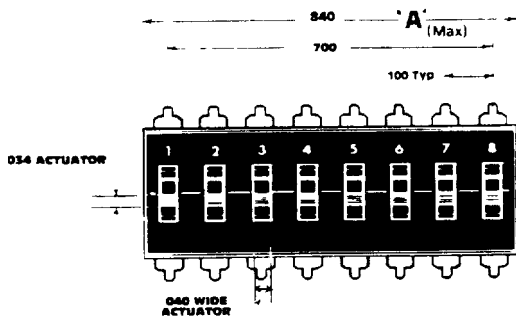

SPECIFICATIONS

Low Profile Dip Switches for Automatic or Manual Insertion

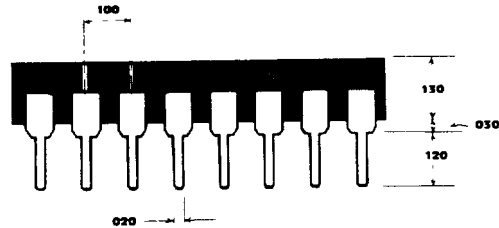
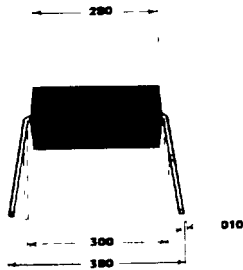

SPST-FLUSH ACTUATORS		
"A" OVERALL DIMENSION	NUMBER OF SWITCH POSITIONS	PART NUMBER
.840	8	M40 8S
.720	7	M40 7S
.620	6	M40 6S
.520	5	M40 5S
.420	4	M40 4S
.320	3	M40 3S
.220	2	M40 2S

ELECTRICAL

Contact Resistance

Initial, max. 20 Milliohms
 After 2000 actuation, max. 80 Milliohms

Current and Voltage Ratings, max.

Switching 100mA @ 20VDC
 Non-switching 100mA @ 50VDC
 Insulation Resistance, initial 1000meg Ω 500VDC
 Dielectric Withstanding Voltage, min. 500VDC
 Capacitance, max., between adjacent switches 5 Picofarads

ENVIRONMENTAL

Temperature Rating

Operating -40°C to +100°C
 Storage -60°C to +125°C
 Humidity 95% RH, 40°C for 96 Hours
 Vibration Per MIL-STD-202, Method 204B
 Shock Per MIL-STD-202, Method 213C
 Solderability Per MIL-STD-202, Method 208
 Mechanical Life 2000 Actuations, 80 Milliohms, Max.

PHYSICAL

Housing 30% Glass Filled 6/6 Nylon (UL 94VO)
 Lead Frame Contacts Brass, 30 Microinch Gold Over 50 Microinch Nickel at Contact Points
 Leads Solder Plating
 Slide Contacts Beryllium Copper, 30 Microinch Gold Over 100 Microinch Nickel

SURFACE MOUNT DIP SWITCHES

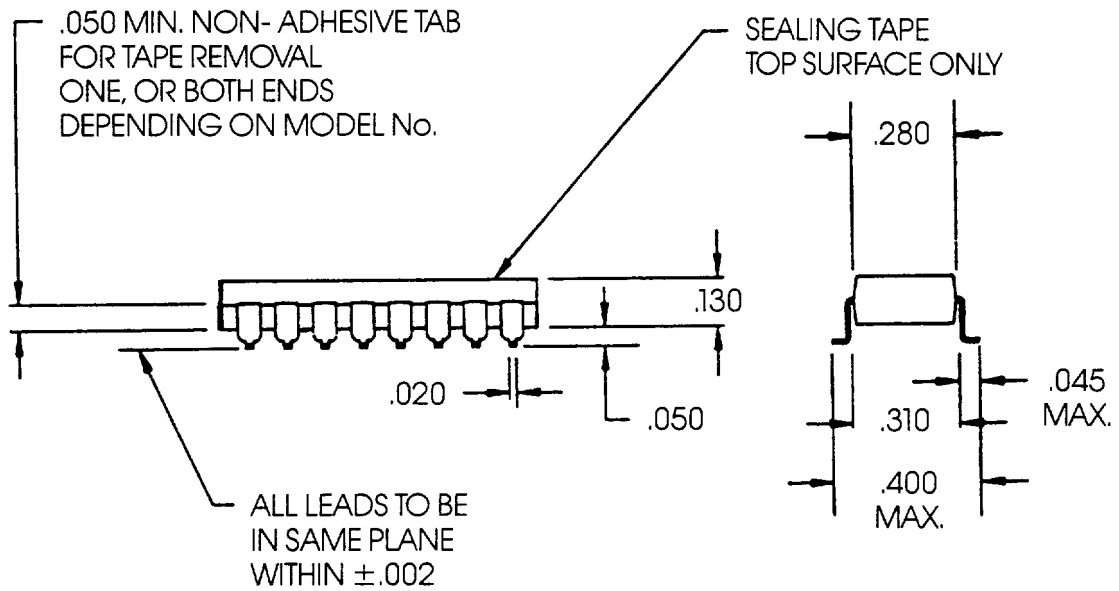
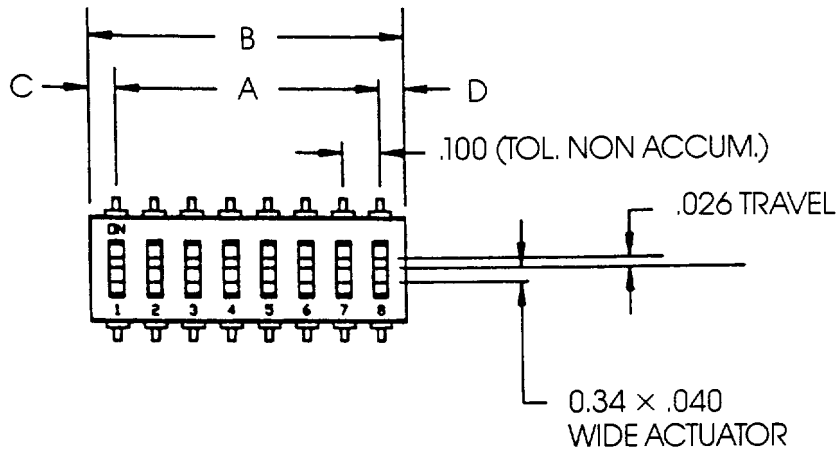

Dimensions in inches

MODEL NO.	A	B	C	D
M40 8SM	.700	.840	.070	.070
M40 7SM	.600	.715	.070	.045
M40 6SM	.500	.615	.070	.045
M40 5SM	.400	.515	.045	.070
M40 4SM	.300	.415	.045 or .070	.070 or .045
M40 3SM	.200	.315	.070	.045
M40 2SM	.100	.215	.045	.070