



**MCP7386X**  
**Battery Charger**  
**Evaluation Board**  
**User's Guide**

---

**Note the following details of the code protection feature on Microchip devices:**

- Microchip products meet the specification contained in their particular Microchip Data Sheet.
- Microchip believes that its family of products is one of the most secure families of its kind on the market today, when used in the intended manner and under normal conditions.
- There are dishonest and possibly illegal methods used to breach the code protection feature. All of these methods, to our knowledge, require using the Microchip products in a manner outside the operating specifications contained in Microchip's Data Sheets. Most likely, the person doing so is engaged in theft of intellectual property.
- Microchip is willing to work with the customer who is concerned about the integrity of their code.
- Neither Microchip nor any other semiconductor manufacturer can guarantee the security of their code. Code protection does not mean that we are guaranteeing the product as "unbreakable."

Code protection is constantly evolving. We at Microchip are committed to continuously improving the code protection features of our products. Attempts to break Microchip's code protection feature may be a violation of the Digital Millennium Copyright Act. If such acts allow unauthorized access to your software or other copyrighted work, you may have a right to sue for relief under that Act.

---

Information contained in this publication regarding device applications and the like is provided only for your convenience and may be superseded by updates. It is your responsibility to ensure that your application meets with your specifications. MICROCHIP MAKES NO REPRESENTATIONS OR WARRANTIES OF ANY KIND WHETHER EXPRESS OR IMPLIED, WRITTEN OR ORAL, STATUTORY OR OTHERWISE, RELATED TO THE INFORMATION, INCLUDING BUT NOT LIMITED TO ITS CONDITION, QUALITY, PERFORMANCE, MERCHANTABILITY OR FITNESS FOR PURPOSE. Microchip disclaims all liability arising from this information and its use. Use of Microchip's products as critical components in life support systems is not authorized except with express written approval by Microchip. No licenses are conveyed, implicitly or otherwise, under any Microchip intellectual property rights.

**Trademarks**

The Microchip name and logo, the Microchip logo, Accuron, dsPIC, KEELOQ, microID, MPLAB, PIC, PICmicro, PICSTART, PRO MATE, PowerSmart, rfPIC, and SmartShunt are registered trademarks of Microchip Technology Incorporated in the U.S.A. and other countries.

AmpLab, FilterLab, Migratable Memory, MXDEV, MXLAB, PICMASTER, SEEVAL, SmartSensor and The Embedded Control Solutions Company are registered trademarks of Microchip Technology Incorporated in the U.S.A.

Analog-for-the-Digital Age, Application Maestro, dsPICDEM, dsPICDEM.net, dsPICworks, ECAN, ECONOMONITOR, FanSense, FlexROM, fuzzyLAB, In-Circuit Serial Programming, ICSP, ICEPIC, Linear Active Thermistor, MPASM, MPLIB, MPLINK, MPSIM, PICKit, PICDEM, PICDEM.net, PICLAB, PICTail, PowerCal, PowerInfo, PowerMate, PowerTool, rFLAB, rfPICDEM, Select Mode, Smart Serial, SmartTel, Total Endurance and WiperLock are trademarks of Microchip Technology Incorporated in the U.S.A. and other countries.

SQTP is a service mark of Microchip Technology Incorporated in the U.S.A.

All other trademarks mentioned herein are property of their respective companies.

© 2005, Microchip Technology Incorporated, Printed in the U.S.A., All Rights Reserved.

 Printed on recycled paper.

**QUALITY MANAGEMENT SYSTEM  
CERTIFIED BY DNV  
== ISO/TS 16949:2002 ==**

*Microchip received ISO/TS-16949:2002 quality system certification for its worldwide headquarters, design and wafer fabrication facilities in Chandler and Tempe, Arizona and Mountain View, California in October 2003. The Company's quality system processes and procedures are for its PICmicro® 8-bit MCUs, KEELOQ® code hopping devices, Serial EEPROMs, microperipherals, nonvolatile memory and analog products. In addition, Microchip's quality system for the design and manufacture of development systems is ISO 9001:2000 certified.*



# MCP7386X EVALUATION BOARD USER'S GUIDE

---

---

## Table of Contents

---

---

<b>Preface</b> .....	<b>1</b>
<b>Chapter 1. Product Overview</b>	
1.1 Introduction and Highlights .....	5
1.2 What is the MCP7386X Battery Charger Evaluation Board? .....	5
1.3 What the MCP7386X Battery Charger Evaluation Board Includes .....	5
<b>Chapter 2. Installation and Operation</b>	
2.1 Features .....	7
2.2 Getting Started .....	7
2.3 Detailed Description .....	8
<b>Appendix A. Schematic and Layouts</b>	
A.1 Introduction .....	11
A.2 Board Schematic .....	12
A.3 Board – Top Layer .....	13
A.4 Board – Silk-Screen Layer .....	14
A.5 Board – Bottom Layer .....	15
<b>Appendix B. Bill Of Materials (BOM)</b>	
<b>Worldwide Sales and Service</b> .....	<b>18</b>

# MCP7386X Evaluation Board User's Guide

---

NOTES:

---

---

## Preface

---

---

### NOTICE TO CUSTOMERS

All documentation becomes dated, and this manual is no exception. Microchip tools and documentation are constantly evolving to meet customer needs, so some actual dialogs and/or tool descriptions may differ from those in this document. Please refer to our web site ([www.microchip.com](http://www.microchip.com)) to obtain the latest documentation available.

Documents are identified with a “DS” number. This number is located on the bottom of each page, in front of the page number. The numbering convention for the DS number is “DSXXXXA”, where “XXXX” is the document number and “A” is the revision level of the document.

## INTRODUCTION

This chapter contains general information that will be useful to know before using the MCP7386X Battery Charger Evaluation Board. Items discussed in this chapter include:

- Document Layout
- Conventions Used in this Guide
- Recommended Reading
- The Microchip Web Site
- Customer Support
- Document Revision History

## DOCUMENT LAYOUT

This document describes how to use the MCP7386X Battery Charger Evaluation Board as a development tool to emulate and debug firmware on a target board. The manual layout is as follows:

- **Chapter 1. “Product Overview”** – Important information about the MCP7386X Battery Charger Evaluation Board.
- **Chapter 2. “Installation and Operation”** – For users evaluating the MCP73861/2/3/4 devices, this chapter describes how to use the various features of the hardware.
- **Appendix A. “Schematic and Layouts”** – Shows the schematic and layout diagrams for the MCP7386X Battery Charger Evaluation Board.
- **Appendix B. “Bill Of Materials (BOM)”** – Lists the parts used to build the MCP7386X Battery Charger Evaluation Board.

# MCP7386X Evaluation Board User's Guide

## CONVENTIONS USED IN THIS GUIDE

This manual uses the following documentation conventions:

### DOCUMENTATION CONVENTIONS

Description	Represents	Examples
<b>Arial font:</b>		
Italic characters	Referenced books	<i>MPLAB<sup>®</sup> IDE User's Guide</i>
	Emphasized text	...is the <i>only</i> compiler...
Initial caps	A window	the Output window
	A dialog	the Settings dialog
	A menu selection	select Enable Programmer
Quotes	A field name in a window or dialog	"Save project before build"
Underlined, italic text with right angle bracket	A menu path	<u><i>File&gt;Save</i></u>
Bold characters	A dialog button	Click <b>OK</b>
	A tab	Click the <b>Power</b> tab
Text in angle brackets < >	A key on the keyboard	Press <Enter>, <F1>
<b>Courier New font:</b>		
Plain Courier New	Sample source code	#define START
	Filenames	autoexec.bat
	File paths	c:\mcc18\h
	Keywords	_asm, _endasm, static
	Command-line options	-Opa+, -Opa-
	Bit values	0, 1
	Constants	0xFF, 'A'
Italic Courier New	A variable argument	<i>file.o</i> , where <i>file</i> can be any valid filename
Square brackets [ ]	Optional arguments	mcc18 [options] <i>file</i> [options]
Curly brackets and pipe character: {   }	Choice of mutually exclusive arguments; an OR selection	errorlevel {0 1}
Ellipses...	Replaces repeated text	var_name [, var_name...]
	Represents code supplied by user	void main (void) { ... }

## RECOMMENDED READING

This user's guide describes how to use the MCP7386X Battery Charger Evaluation Board. Other useful documents are listed below. The following Microchip documents are available and recommended as supplemental reference resources.

### **MCP73861/2/3/4 Data Sheet, "Advanced Single or Dual-Cell, Fully-Integrated Li-Ion/Li-Polymer Charge Management Controllers" (DS21893)**

This data sheet provides detailed information regarding the MCP73861 Advanced Single or Dual-Cell, Fully-Integrated, Lithium-Ion/Lithium-Polymer Charge Management Controllers.

## THE MICROCHIP WEB SITE

Microchip provides online support via our web site at [www.microchip.com](http://www.microchip.com). This web site is used as a means to make files and information easily available to customers. Accessible by using your favorite Internet browser, the web site contains the following information:

- **Product Support** – Data sheets and errata, application notes and sample programs, design resources, user's guides and hardware support documents, latest software releases and archived software
- **General Technical Support** – Frequently Asked Questions (FAQs), technical support requests, online discussion groups, Microchip consultant program member listing
- **Business of Microchip** – Product selector and ordering guides, latest Microchip press releases, listing of seminars and events, listings of Microchip sales offices, distributors and factory representatives

## CUSTOMER SUPPORT

Users of Microchip products can receive assistance through several channels:

- Distributor or Representative
- Local Sales Office
- Field Application Engineer (FAE)
- Technical Support
- Development Systems Information Line

Customers should contact their distributor, representative or field application engineer (FAE) for support. Local sales offices are also available to help customers. A listing of sales offices and locations is included in the back of this document.

Technical support is available through the web site at: <http://support.microchip.com>

## DOCUMENT REVISION HISTORY

### Revision B (September 2005)

- Added References to MCP73861/2/3/4.

### Revision A (June 2004)

- Initial Release of this Document.

# MCP7386X Evaluation Board User's Guide

---

NOTES:



---

---

## Chapter 1. Product Overview

---

---

### 1.1 INTRODUCTION

This chapter provides an overview of the MCP7386X Battery Charger Evaluation Board and covers the following topics:

- What is the MCP7386X Battery Charger Evaluation Board?
- What the MCP7386X Battery Charger Evaluation Board Includes

### 1.2 WHAT IS THE MCP7386X BATTERY CHARGER EVALUATION BOARD?

The MCP7386X Battery Charger Evaluation Board is an evaluation and demonstration tool for Microchip Technology's MCP7386X Advanced Single or Dual-Cell, Fully-Integrated, Lithium-Ion/Lithium-Polymer Charge Management Controllers. The design provides for dynamic versatility while being able to handle accurate measurements.

When connected, this evaluation board allows for the evaluation of the MCP7386X devices in a variety of applications.

### 1.3 WHAT THE MCP7386X BATTERY CHARGER EVALUATION BOARD INCLUDES

This MCP7386X Battery Charger Evaluation Board Kit includes:

- The MCP7386X Battery Charger Evaluation Board
- MCP73861 Device (Installed)
- MCP73861/2/3/4 Data Sheet (DS21893)
- MCP7386X Battery Charger Evaluation Board User's Guide (DS51475)

# MCP7386X Evaluation Board User's Guide

---

NOTES:

---

---

## Chapter 2. Installation and Operation

---

---

### 2.1 FEATURES

The MCP7386X Battery Charger Evaluation Board has the following features:

- Evaluation of MCP7386X devices in 4 x 4, 16-lead QFN packages
- Simple, stand-alone operation or microcontroller-compatible
- Powered from external bench supply or wall cube
- Surface-mount design
- Fully assembled and tested

### 2.2 GETTING STARTED

The MCP7386X Battery Charger Evaluation Board is a fully-functional, assembled and tested surface-mount board for evaluation of Microchip's MCP7386X Advanced Single or Dual-Cell, Fully Integrated Lithium-Ion/Lithium-Polymer Charge Management Controllers. The following steps provide simple, stand-alone operation. Refer to Figure 2-1 for the setup configuration diagram. The setup configuration diagram depicts evaluation of the installed MCP73861 for single-cell applications.

1. Connect an external bench supply or wall cube to the surface-mount test points provided. The input voltage source should be in the range of 5V to 12V. Refer to **Section 2.3.1 "Input Source"** for details on the input source requirements.

**Note:** Observe correct polarity of connection. Positive terminal connects to J2 ( $V_{IN+}$ ); negative terminal connects to J3 ( $V_{IN-}$ ).

2. Connect a single-cell Lithium-Ion or Lithium-Polymer battery pack to the circuit for evaluation.

**Note:** Observe correct polarity of connection. Positive terminal connects to J5 ( $V_{BAT+}$ ); negative terminal connects to J6 ( $V_{BAT-}$ ).

3. Connect an external battery pack thermistor to the J7 (THERM) input. The thermistor should be connected from J7 (THERM) to J6 ( $V_{BAT-}$ ). If continuous cell temperature monitoring is not desired, place a 10 k $\Omega$  resistor from THERM to  $V_{BAT-}$ , or populate R5 with a 10 k $\Omega$  resistor.
4. Turn on the bench supply or plug in the wall cube.
5. A green LED ( $D_1$ ) provides status during the charge cycle. A red LED ( $D_2$ ) indicates a Fault condition. Refer to the MCP73861/2/3/4 data sheet (DS21893) for details.

# MCP7386X Evaluation Board User's Guide

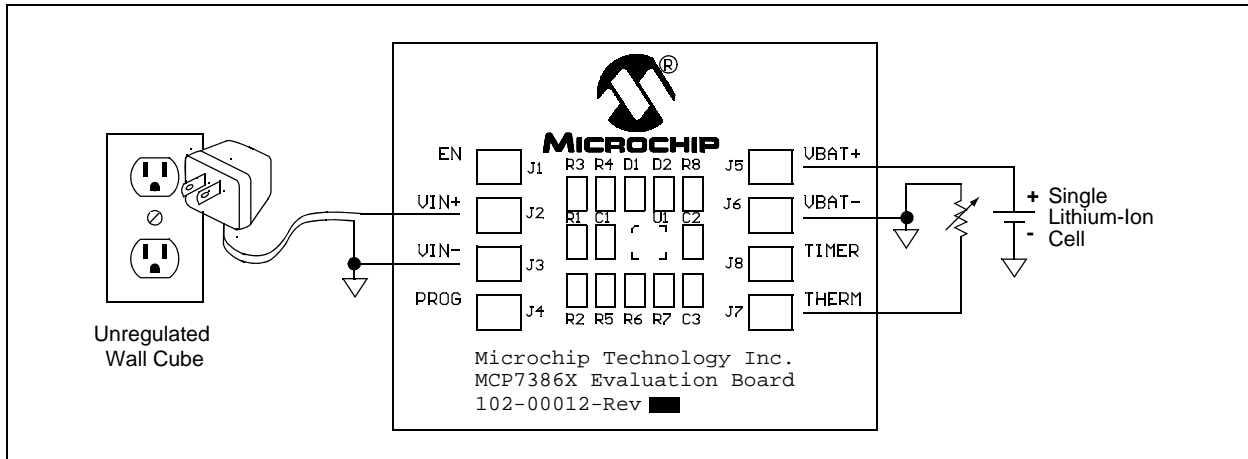

FIGURE 2-1: Setup Configuration Diagram.

## 2.3 DETAILED DESCRIPTION

The MCP7386X Battery Charger Evaluation Board is set up to evaluate simple, stand-alone, linear charging of single/dual-cell Lithium-Ion/Lithium-Polymer battery packs. The reference design provides constant current charging, followed by constant voltage charging with automatic charge termination. As provided, the MCP7386X Battery Charger Evaluation Board is set for a fast charge, constant current level of 1.2A, typical for single-cell applications. The MCP73861 is provided in a 4 x 4, 16-lead QFN package and is equipped with shutdown control, status indicator, fault indicator, safety timer and a continuous cell temperature monitor. For dual-cell applications, the MCP73862 or MCP73864 can be substituted for the MCP73861. Refer to the MCP73861/2/3/4 data sheet (DS21893) for details on the individual device features.

### 2.3.1 Input Source

The MCP7386X Battery Charger Evaluation Board is designed to provide a fast charge current of 1.2A, typical. The input source should provide a voltage in the range of 5V to 12V. The input source should be capable of providing a minimum of 7.5W.

Lower peak currents can be obtained by adjusting the value of the charge programming resistors ( $R_2$ ). A corresponding lower-power input source may then be utilized. Refer to the MCP73861/2/3/4 data sheet (DS21893) for details on determining the appropriate programming resistor.

### 2.3.2 Safety Timer Periods

The MCP7386X Battery Charger Evaluation Board can be used with a variety of battery packs. As provided, the MCP7386X Battery Charger Evaluation Board is set up to perform well with single-cell, 1000 mAh battery packs. Battery packs with alternative capacities and various charge currents can be implemented. The safety timer periods may need to be adjusted in order to ensure a full charge. The safety timer periods can be adjusted by changing the capacitance of  $C_3$ . Refer to the MCP73861/2/3/4 data sheet (DS21893) for details on determining the appropriate timer capacitance.

### 2.3.3 Disable Control

The MCP7386X Battery Charger Evaluation Board is designed to provide stand-alone operation. The installed MCP73861 device is enabled whenever the input source is present. To disable charging, a jumper can be placed between J1, EN and J3 ( $V_{IN-}$ ).

## 2.3.4 Battery Headers

Independent battery connections are provided. The battery pack positive terminal should be connected to J5 ( $V_{BAT+}$ ). The battery pack negative terminal should be connected to J6 ( $V_{BAT-}$ ). In addition, a connection is provided for a nominal 10 k $\Omega$  at +25°C NTC thermistor, situated in the battery pack for temperature sensing. When the cell temperature is between -5°C and +55°C, installed resistors provide a charging window when a thermistor with a sensitivity index ( $\beta$ ) of 3982 is utilized. Charging is inhibited when the cell temperature deviates outside the preset window. The resistor values can be adjusted to provide the desired charging window for a variety of thermistors. Refer to the MCP73861/2/3/4 data sheet (DS21893) for details.

<p><b>Note:</b> Improper connection of the battery may result in damage to the battery and increase the possibility of personal injury. It is also important to avoid shorting the battery terminals together.</p>
--

## 2.3.5 Device Support Options

The MCP7386X Battery Charger Evaluation Board supports the entire MCP7386X family. The MCP7386X Battery Charger Evaluation Board is provided with one reference design utilizing the MCP73861. Alternate devices can be substituted in order to evaluate the different MCP7386X family options.

## 2.3.6 Microcontroller Option

Connection points provide easily-accessible locations for interface to a host microcontroller. The host microcontroller can be used to disable the charger, monitor charge status or terminate a charge.

## 2.3.7 Output Voltage Options

The MCP7386X Battery Charger Evaluation Board is provided with a Constant-Voltage mode output voltage of 4.2V per cell, the evaluation of which can be achieved by moving resistor  $R_4$  to  $R_3$ , or by shorting the  $R_3$  pads.

# MCP7386X Evaluation Board User's Guide

---

NOTES:



# MCP7386X EVALUATION BOARD USER'S GUIDE

---

---

## Appendix A. Schematic and Layouts

---

---

### A.1 INTRODUCTION

This appendix contains the following schematics and layouts for the MCP7386X Evaluation Board:

- Board Schematic
- Board – Top Layer
- Board – Silk-Screen Layer
- Board – Bottom Layer

# MCP7386X Evaluation Board User's Guide

## A.2 BOARD SCHEMATIC

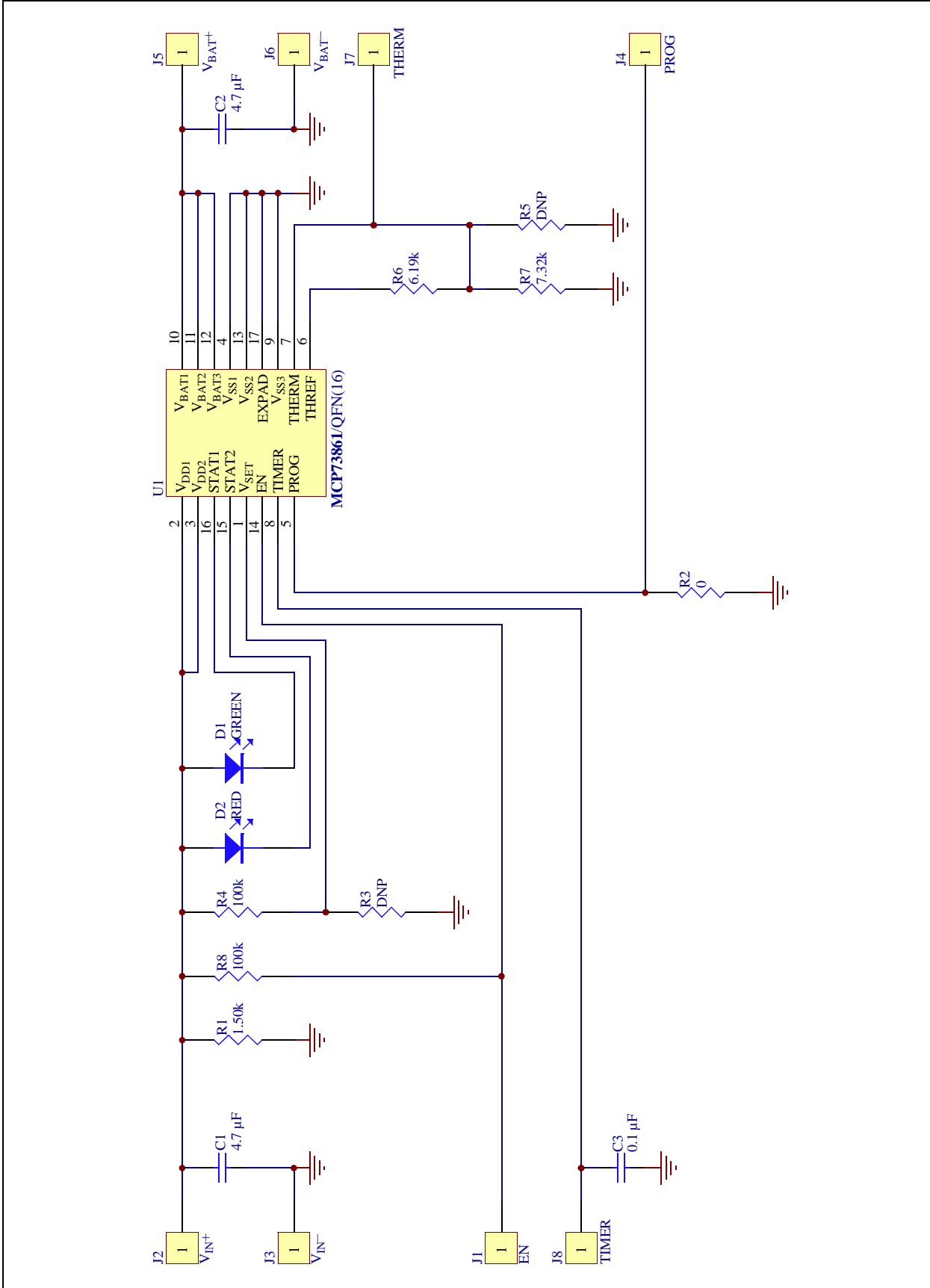



## A.3 BOARD – TOP LAYER

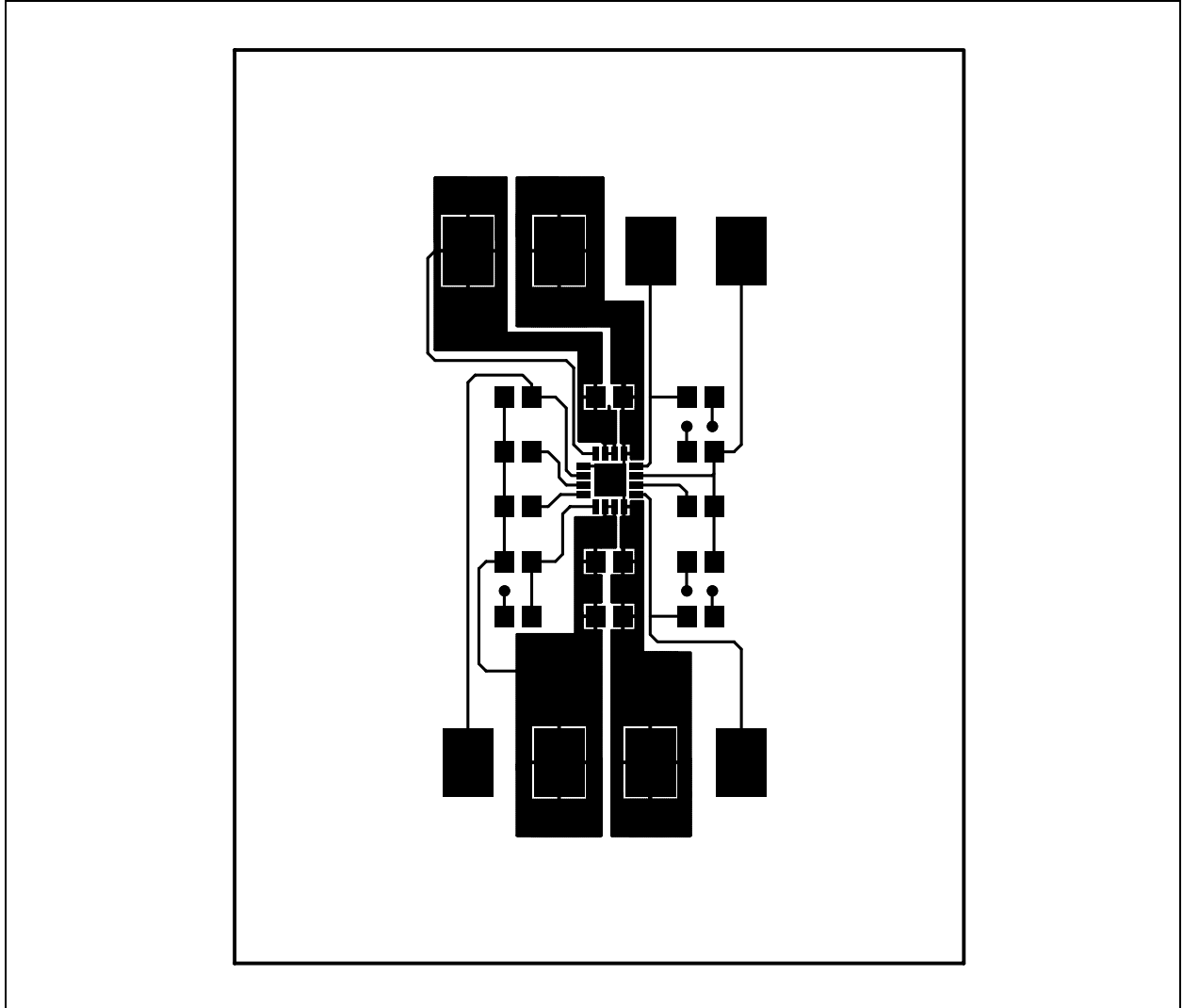

# MCP7386X Evaluation Board User's Guide

## A.4 BOARD – SILK-SCREEN LAYER

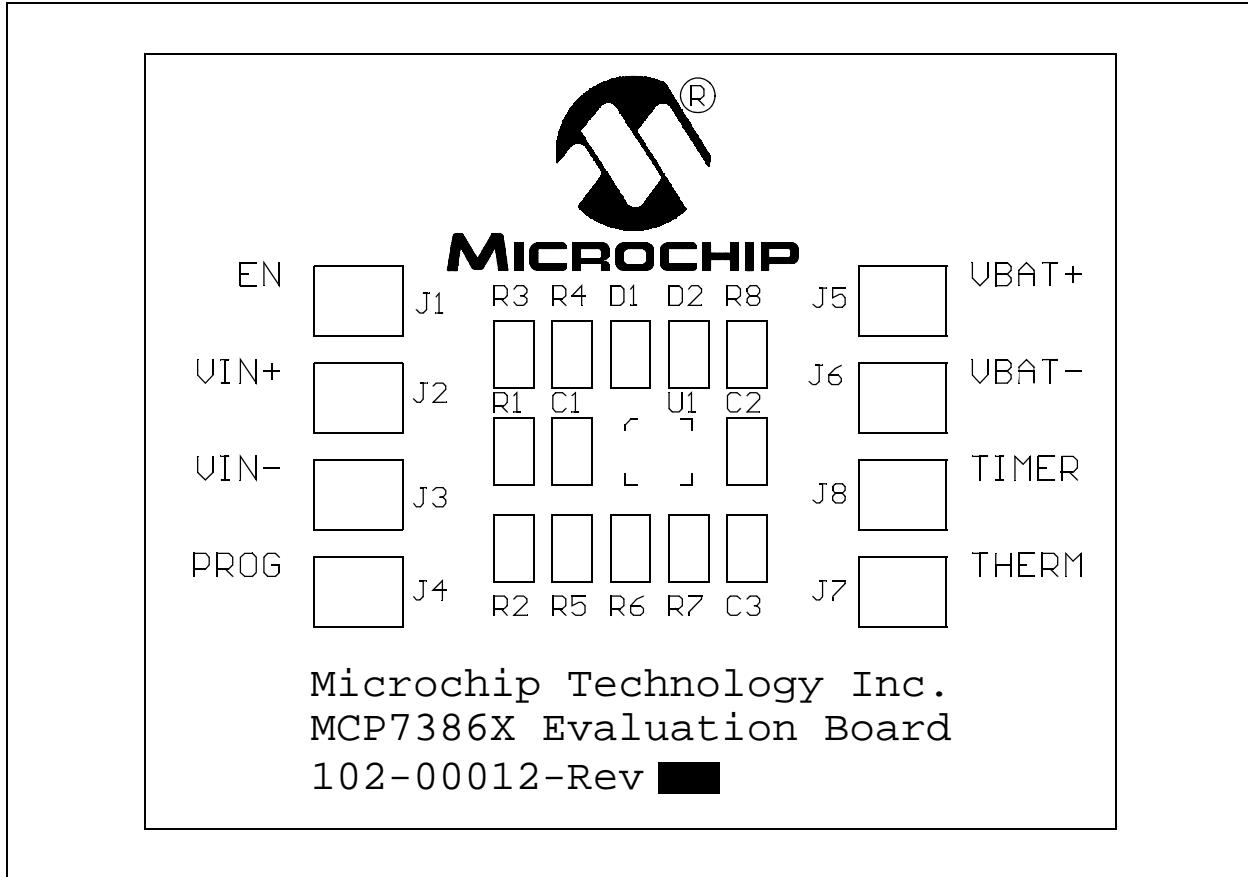

## A.5 BOARD – BOTTOM LAYER

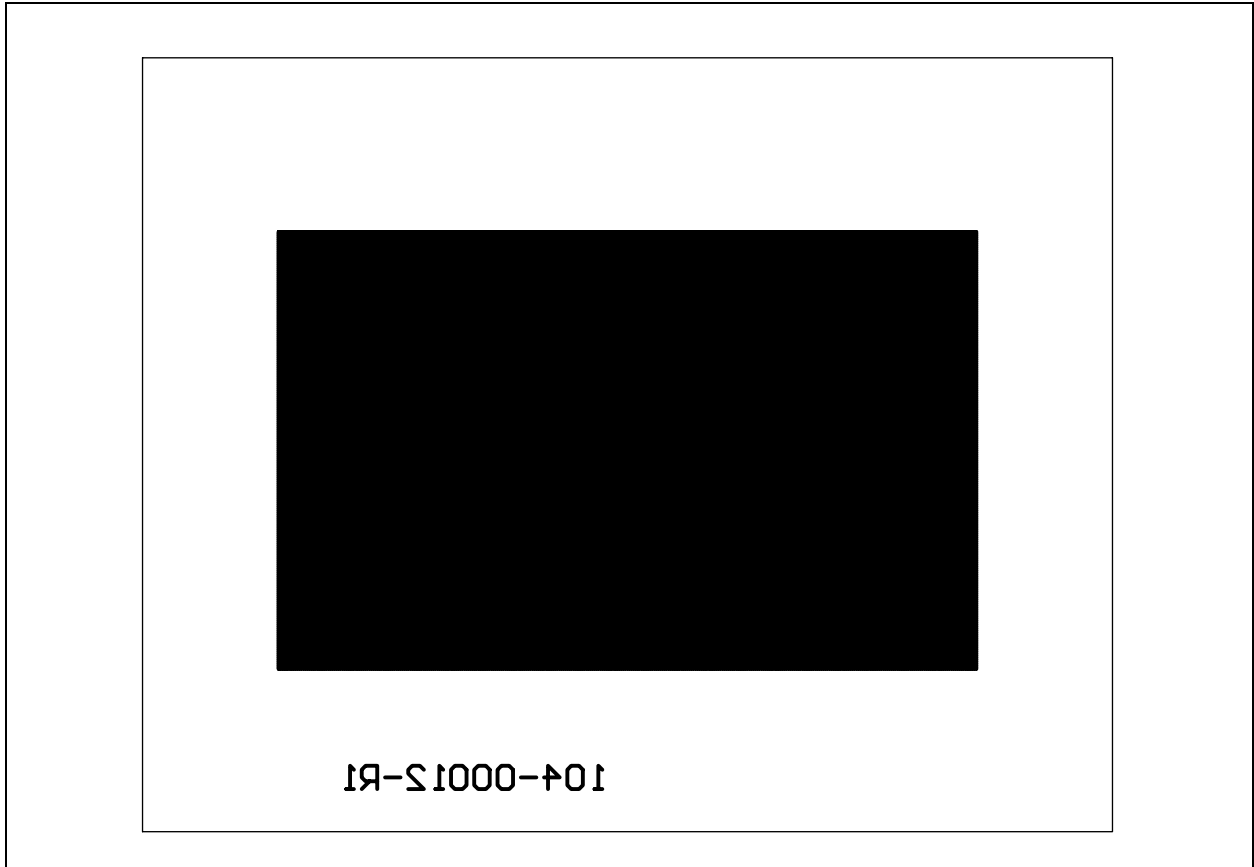

# MCP7386X Evaluation Board User's Guide

---

NOTES:

**Appendix B. Bill Of Materials (BOM)**

**TABLE B-1: BILL OF MATERIALS (BOM)**

Reference Designator	Quantity	Description	Manufacturer	Manufacturer Part Number
C1, C2	2	4.7 $\mu$ F, X5R Ceramic, 16V, 0805	Panasonic <sup>®</sup>	ECJ-2FB1C475K
C3	1	0.1 $\mu$ F, X7R Ceramic, 16V, 0805	Panasonic	ECJ-2VB1C104K
D1	1	Green LED, 0805	Lumex <sup>®</sup> Opto/ Components Inc.	SML-LXT0805GW
D2	1	Red LED, 0805	Lumex Opto/ Components Inc.	SML-LXT0805SRW
J1 - J8	8	Surface-Mount Test Point, 5016	Keystone <sup>®</sup> Electronics	5016
R1	1	1.5 k $\Omega$ , 1/8W, Chip Resistor, 0805	Panasonic	ERJ-6GEYJ152V
R2	1	0 $\Omega$ Jumper, 0805	Panasonic	ERJ-6GEY0R00V
R3, R5	0	DNP, 0805		
R4, R8	2	100 k $\Omega$ , 1/10W, Chip Resistor, 0805	Panasonic	ERJ-6ENF1003V
R6	1	6.19 k $\Omega$ , 1/10W, Chip Resistor, 0805	Panasonic	ERJ-6ENF6191V
R7	1	7.32 k $\Omega$ , 1/10W, Chip Resistor, 0805	Panasonic	ERJ-6ENF7321V
U1	1	Single-Cell Lithium-Ion Charger, 4X4QFN16	Microchip Technology Inc.	MCP73861-I/MLG



---

---

## WORLDWIDE SALES AND SERVICE

---

---

### AMERICAS

**Corporate Office**  
2355 West Chandler Blvd.  
Chandler, AZ 85224-6199  
Tel: 480-792-7200  
Fax: 480-792-7277  
Technical Support:  
<http://support.microchip.com>  
Web Address:  
[www.microchip.com](http://www.microchip.com)

**Atlanta**  
Alpharetta, GA  
Tel: 770-640-0034  
Fax: 770-640-0307

**Boston**  
Westborough, MA  
Tel: 774-760-0087  
Fax: 774-760-0088

**Chicago**  
Itasca, IL  
Tel: 630-285-0071  
Fax: 630-285-0075

**Dallas**  
Addison, TX  
Tel: 972-818-7423  
Fax: 972-818-2924

**Detroit**  
Farmington Hills, MI  
Tel: 248-538-2250  
Fax: 248-538-2260

**Kokomo**  
Kokomo, IN  
Tel: 765-864-8360  
Fax: 765-864-8387

**Los Angeles**  
Mission Viejo, CA  
Tel: 949-462-9523  
Fax: 949-462-9608

**San Jose**  
Mountain View, CA  
Tel: 650-215-1444  
Fax: 650-961-0286

**Toronto**  
Mississauga, Ontario,  
Canada  
Tel: 905-673-0699  
Fax: 905-673-6509

### ASIA/PACIFIC

**Australia - Sydney**  
Tel: 61-2-9868-6733  
Fax: 61-2-9868-6755

**China - Beijing**  
Tel: 86-10-8528-2100  
Fax: 86-10-8528-2104

**China - Chengdu**  
Tel: 86-28-8676-6200  
Fax: 86-28-8676-6599

**China - Fuzhou**  
Tel: 86-591-8750-3506  
Fax: 86-591-8750-3521

**China - Hong Kong SAR**  
Tel: 852-2401-1200  
Fax: 852-2401-3431

**China - Qingdao**  
Tel: 86-532-8502-7355  
Fax: 86-532-8502-7205

**China - Shanghai**  
Tel: 86-21-5407-5533  
Fax: 86-21-5407-5066

**China - Shenyang**  
Tel: 86-24-2334-2829  
Fax: 86-24-2334-2393

**China - Shenzhen**  
Tel: 86-755-8203-2660  
Fax: 86-755-8203-1760

**China - Shunde**  
Tel: 86-757-2839-5507  
Fax: 86-757-2839-5571

**China - Wuhan**  
Tel: 86-27-5980-5300  
Fax: 86-27-5980-5118

**China - Xian**  
Tel: 86-29-8833-7250  
Fax: 86-29-8833-7256

### ASIA/PACIFIC

**India - Bangalore**  
Tel: 91-80-2229-0061  
Fax: 91-80-2229-0062

**India - New Delhi**  
Tel: 91-11-5160-8631  
Fax: 91-11-5160-8632

**India - Pune**  
Tel: 91-20-2566-1512  
Fax: 91-20-2566-1513

**Japan - Yokohama**  
Tel: 81-45-471- 6166  
Fax: 81-45-471-6122

**Korea - Gumi**  
Tel: 82-54-473-4301  
Fax: 82-54-473-4302

**Korea - Seoul**  
Tel: 82-2-554-7200  
Fax: 82-2-558-5932 or  
82-2-558-5934

**Malaysia - Penang**  
Tel: 604-646-8870  
Fax: 604-646-5086

**Philippines - Manila**  
Tel: 632-634-9065  
Fax: 632-634-9069

**Singapore**  
Tel: 65-6334-8870  
Fax: 65-6334-8850

**Taiwan - Hsin Chu**  
Tel: 886-3-572-9526  
Fax: 886-3-572-6459

**Taiwan - Kaohsiung**  
Tel: 886-7-536-4818  
Fax: 886-7-536-4803

**Taiwan - Taipei**  
Tel: 886-2-2500-6610  
Fax: 886-2-2508-0102

**Thailand - Bangkok**  
Tel: 66-2-694-1351  
Fax: 66-2-694-1350

### EUROPE

**Austria - Weis**  
Tel: 43-7242-2244-399  
Fax: 43-7242-2244-393

**Denmark - Copenhagen**  
Tel: 45-4450-2828  
Fax: 45-4485-2829

**France - Paris**  
Tel: 33-1-69-53-63-20  
Fax: 33-1-69-30-90-79

**Germany - Munich**  
Tel: 49-89-627-144-0  
Fax: 49-89-627-144-44

**Italy - Milan**  
Tel: 39-0331-742611  
Fax: 39-0331-466781

**Netherlands - Drunen**  
Tel: 31-416-690399  
Fax: 31-416-690340

**Spain - Madrid**  
Tel: 34-91-352-30-52  
Fax: 34-91-352-11-47

**UK - Wokingham**  
Tel: 44-118-921-5869  
Fax: 44-118-921-5820



08/24/05