



MCP9800 Thermal Sensor PICtail™ Demo Board User's Guide

Note the following details of the code protection feature on Microchip devices:

- Microchip products meet the specification contained in their particular Microchip Data Sheet.
- Microchip believes that its family of products is one of the most secure families of its kind on the market today, when used in the intended manner and under normal conditions.
- There are dishonest and possibly illegal methods used to breach the code protection feature. All of these methods, to our knowledge, require using the Microchip products in a manner outside the operating specifications contained in Microchip's Data Sheets. Most likely, the person doing so is engaged in theft of intellectual property.
- Microchip is willing to work with the customer who is concerned about the integrity of their code.
- Neither Microchip nor any other semiconductor manufacturer can guarantee the security of their code. Code protection does not mean that we are guaranteeing the product as "unbreakable."

Code protection is constantly evolving. We at Microchip are committed to continuously improving the code protection features of our products. Attempts to break Microchip's code protection feature may be a violation of the Digital Millennium Copyright Act. If such acts allow unauthorized access to your software or other copyrighted work, you may have a right to sue for relief under that Act.

Information contained in this publication regarding device applications and the like is provided only for your convenience and may be superseded by updates. It is your responsibility to ensure that your application meets with your specifications. MICROCHIP MAKES NO REPRESENTATIONS OR WARRANTIES OF ANY KIND WHETHER EXPRESS OR IMPLIED, WRITTEN OR ORAL, STATUTORY OR OTHERWISE, RELATED TO THE INFORMATION, INCLUDING BUT NOT LIMITED TO ITS CONDITION, QUALITY, PERFORMANCE, MERCHANTABILITY OR FITNESS FOR PURPOSE. Microchip disclaims all liability arising from this information and its use. Use of Microchip's products as critical components in life support systems is not authorized except with express written approval by Microchip. No licenses are conveyed, implicitly or otherwise, under any Microchip intellectual property rights.

Trademarks

The Microchip name and logo, the Microchip logo, Accuron, dsPIC, KEELOQ, microID, MPLAB, PIC, PICmicro, PICSTART, PRO MATE, PowerSmart, rfPIC, and SmartShunt are registered trademarks of Microchip Technology Incorporated in the U.S.A. and other countries.

AmpLab, FilterLab, Migratable Memory, MXDEV, MXLAB, PICMASTER, SEEVAL, SmartSensor and The Embedded Control Solutions Company are registered trademarks of Microchip Technology Incorporated in the U.S.A.

Analog-for-the-Digital Age, Application Maestro, dsPICDEM, dsPICDEM.net, dsPICworks, ECAN, ECONOMONITOR, FanSense, FlexROM, fuzzyLAB, In-Circuit Serial Programming, ICSP, ICEPIC, MPASM, MPLIB, MPLINK, MPSIM, PICkit, PICDEM, PICDEM.net, PICLAB, PICtail, PowerCal, PowerInfo, PowerMate, PowerTool, rfLAB, rfPICDEM, Select Mode, Smart Serial, SmartTel and Total Endurance are trademarks of Microchip Technology Incorporated in the U.S.A. and other countries.

SQTP is a service mark of Microchip Technology Incorporated in the U.S.A.

All other trademarks mentioned herein are property of their respective companies.

© 2005, Microchip Technology Incorporated, Printed in the U.S.A., All Rights Reserved.

 Printed on recycled paper.

QUALITY MANAGEMENT SYSTEM
CERTIFIED BY DNV
== ISO/TS 16949:2002 ==

Microchip received ISO/TS-16949:2002 quality system certification for its worldwide headquarters, design and wafer fabrication facilities in Chandler and Tempe, Arizona and Mountain View, California in October 2003. The Company's quality system processes and procedures are for its PICmicro® 8-bit MCUs, KEELOQ® code hopping devices, Serial EEPROMs, microperipherals, nonvolatile memory and analog products. In addition, Microchip's quality system for the design and manufacture of development systems is ISO 9001:2000 certified.



MCP9800 THERMAL SENSOR PICtail™ DEMO BOARD USER'S GUIDE

Table of Contents

Preface	1
Chapter 1. Product Overview	5
1.1 Introduction	5
1.2 What is the MCP9800 Thermal Sensor PICtail™ Demo Board?	5
1.3 What the MCP9800 Thermal Sensor PICtail Demo Board Kit Includes ...	5
Chapter 2. Installation and Operation	7
2.1 Introduction	7
2.2 Features	7
2.3 Getting Started	7
2.4 Functional Description	10
Appendix A. Schematic and Layouts	15
A.1 Introduction	15
A.2 Board Schematic	16
A.3 Board - Top Layer	17
A.4 Board - Silk-screen Layer	18
A.5 Board - Bottom Layer	19
Appendix B. Bill-Of-Materials (BOM)	21
Worldwide Sales and Service	22

MCP9800 Thermal Sensor PICtail™ Demo Board User's Guide

NOTES:



MCP9800 THERMAL SENSOR PICtail™ DEMO BOARD USER'S GUIDE

Preface

NOTICE TO CUSTOMERS

All documentation becomes dated, and this manual is no exception. Microchip tools and documentation are constantly evolving to meet customer needs, so some actual dialogs and/or tool descriptions may differ from those in this document. Please refer to our web site (www.microchip.com) to obtain the latest documentation available.

Documents are identified with a "DS" number. This number is located on the bottom of each page, in front of the page number. The numbering convention for the DS number is "DSXXXXA", where "XXXX" is the document number and "A" is the revision level of the document.

For the most up-to-date information on development tools, see the MPLAB® IDE on-line help. Select the Help menu, and then Topics to open a list of available on-line help files.

INTRODUCTION

This chapter contains general information that will be useful to know before using the MCP9800 Thermal Sensor PICtail Demo Board. Items discussed in this chapter include:

- About This Guide
- Recommended Reading
- The Microchip Web Site
- Customer Support

ABOUT THIS GUIDE

Document Layout

This document describes how to use the MCP9800 Thermal Sensor PICtail Demo Board as a development tool to emulate and debug firmware on a target board. The manual layout is as follows:

- **Chapter 1: Overview** – Important information about the MCP9800 Thermal Sensor PICtail Demo Board.
- **Chapter 2: MCP9800 Thermal Sensor PICtail Demo Board** – Includes a detailed description of each function of the demo board and instructions on how to begin using the board.
- **Appendix A: Schematic and Layouts** – Shows the schematic and layout diagrams for the MCP9800 Thermal Sensor PICtail Demo Board.
- **Appendix B: Bill-of-Materials (BOM)** – Lists the parts used to build the MCP9800 Thermal Sensor PICtail Demo Board.

Conventions Used in this Guide

This manual uses the following documentation conventions:

DOCUMENTATION CONVENTIONS

Description	Represents	Examples
Arial font:		
Italic characters	Referenced books	<i>MPLAB® IDE User's Guide</i>
	Emphasized text	...is the <i>only</i> compiler...
Initial caps	A window	the Output window
	A dialog	the Settings dialog
	A menu selection	select Enable Programmer
Quotes	A field name in a window or dialog	"Save project before build"
Underlined, italic text with right angle bracket	A menu path	<u><i>File>Save</i></u>
Bold characters	A dialog button	Click OK
	A tab	Click the Power tab
'bnnnn	A binary number where <i>n</i> is a digit	'b00100, 'b10
Text in angle brackets < >	A key on the keyboard	Press <Enter>, <F1>
Courier font:		
Plain Courier	Sample source code	#define START
	Filenames	autoexec.bat
	File paths	c:\mcc18\h
	Keywords	_asm, _endasm, static
	Command-line options	-Opa+, -Opa-
	Bit values	0, 1
Italic Courier	A variable argument	<i>file.o</i> , where <i>file</i> can be any valid filename
0xnnnn	A hexadecimal number where <i>n</i> is a hexadecimal digit	0xFFFF, 0x007A
Square brackets []	Optional arguments	mcc18 [options] <i>file</i> [options]
Curly brackets and pipe character: { }	Choice of mutually exclusive arguments; an OR selection	errorlevel {0 1}
Ellipses...	Replaces repeated text	var_name [, var_name...]
	Represents code supplied by user	void main (void) { ... }

RECOMMENDED READING

The following Microchip document is available and recommended as a supplemental reference resource.

MCP9800, "2-Wire High-Accuracy Temperature Sensor" Data Sheet (DS21909)

This data sheet provides detailed information regarding the MCP9800 device.

THE MICROCHIP WEB SITE

Microchip provides online support via our web site at www.microchip.com. This web site is used as a means to make files and information easily available to customers. Accessible by using your favorite Internet browser, the web site contains the following information:

- **Product Support** – Data sheets and errata, application notes and sample programs, design resources, user's guides and hardware support documents, latest software releases and archived software
- **General Technical Support** – Frequently Asked Questions (FAQs), technical support requests, online discussion groups, Microchip consultant program member listing
- **Business of Microchip** – Product selector and ordering guides, latest Microchip press releases, listing of seminars and events, listings of Microchip sales offices, distributors and factory representatives

CUSTOMER SUPPORT

Users of Microchip products can receive assistance through several channels:

- Distributor or Representative
- Local Sales Office
- Field Application Engineer (FAE)
- Technical Support
- Development Systems Information Line

Customers should contact their distributor, representative or field application engineer (FAE) for support. Local sales offices are also available to help customers. A listing of sales offices and locations is included in the back of this document.

Technical support is available through the web site at: <http://support.microchip.com>

In addition, there is a Development Systems Information Line which lists the latest versions of Microchip's development systems software products. This line also provides information on how customers can receive currently available upgrade kits.

The Development Systems Information Line numbers are:

1-800-755-2345 – United States and most of Canada

1-480-792-7302 – Other International Locations

REVISION HISTORY

Revision A (January 2005)

- Initial Release of this document.

MCP9800 Thermal Sensor PICtail™ Demo Board User's Guide

NOTES:



MCP9800 THERMAL SENSOR PICtail™ DEMO BOARD USER'S GUIDE

Chapter 1. Product Overview

1.1 INTRODUCTION

This chapter provides an overview of the MCP9800 Thermal Sensor PICtail Demo Board and covers the following topics:

- What is the MCP9800 Thermal Sensor PICtail Demo Board?
- What the MCP9800 Thermal Sensor PICtail Demo Board kit includes

1.2 WHAT IS THE MCP9800 THERMAL SENSOR PICtail DEMO BOARD?

The MCP9800 Thermal Sensor PICtail Demo Board demonstrates how to interface the MCP9800 to a PICmicro® microcontroller using the PICKit™ 1 Flash Starter Kit as a platform. A PIC16F684 14-pin, Flash-based, 8-bit CMOS microcontroller device is included with the demo board and can be used with PICKit 1 Flash Starter Kit. Also included is firmware that provides the I²C™ interface and temperature conversion routines to communicate with the MCP9800 and convert the serial data to temperature.

The MCP9800 Thermal Sensor PICtail Demo Board can also be used as a “stand-alone” module to quickly add thermal-sensing capability to any existing application. This basic sensor functionality is implemented on a small Printed Circuit Board (PCB) and an interface via a standard 100 mil header.

1.3 WHAT THE MCP9800 THERMAL SENSOR PICtail DEMO BOARD KIT INCLUDES

This MCP9800 Thermal Sensor PICtail Demo Board Kit includes:

- The MCP9800 Thermal Sensor PICtail Demo Board
- MCP9800 Thermal Sensor PICtail Demo Board User's Guide
- MCP9800 Data Sheet
- PIC16F684 14-pin, Flash-based, 8-bit, CMOS Microcontroller
- PIC16F684 Firmware

NOTES:

Chapter 2. Installation and Operation

2.1 INTRODUCTION

The MCP9800 Thermal Sensor PICtail Demo Board demonstrates how to interface the MCP9800 to a microcontroller, for use by the system designer as an example of how to integrate a digital temperature sensor into a system. In addition, the designer can serially transmit the temperature data to the onboard, 7-segment LED display to show the temperature.

2.2 FEATURES

The MCP9800 Thermal Sensor PICtail Demo Board has the following features:

- Small PCB layout
- Standard 100 mil 14-pin header (J2) for easy interface to the PICkit™ 1 Flash Starter Kit or custom application
- 7-segment LED display to display temperature in °C or °F
- Temperature alert-indicating LED

2.3 GETTING STARTED

This section describes how to quickly configure the MCP9800 Thermal Sensor PICtail Demo Board and PICkit™ 1 Flash Starter Kit. A block diagram of the configuration is shown in Figure 2-1.

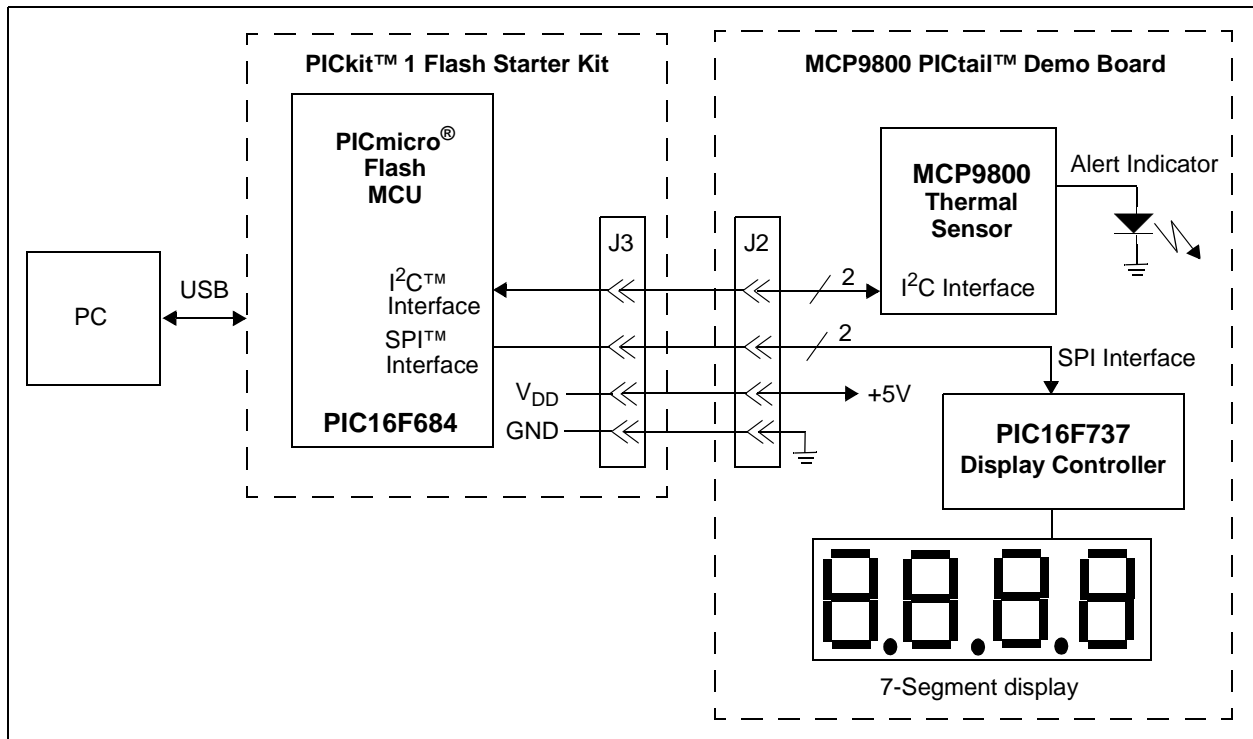

FIGURE 2-1: MCP9800 Thermal Sensor PICtail™ Demo Board Block Diagram.

2.3.1 Hardware Setup

1. Connect the J2 header of the MCP9800 Thermal Sensor PICtail Demo Board to the J3 connector on the PICkit™ 1 Flash Starter Kit. Refer to Figure 2-2 for proper orientation of the MCP9800 Thermal Sensor PICtail Demo Board and Figure 2-3 for a simplified board schematic.
2. Insert the PIC16F684 into the evaluation socket of the PICkit 1 Flash Starter Kit.
3. Connect the PICkit 1 Flash Starter Kit USB cable from the USB port of the PC to the USB port (J1) on the PICkit 1 Flash Starter Kit. +5V of power is supplied to the PICkit 1 Flash Starter Kit via the USB cable. The green power LED and the red busy LED will turn on, indicating that power is being supplied to the board.

WARNING

Do not hot-swap the MCP9800 PICtail™ Demo Board.

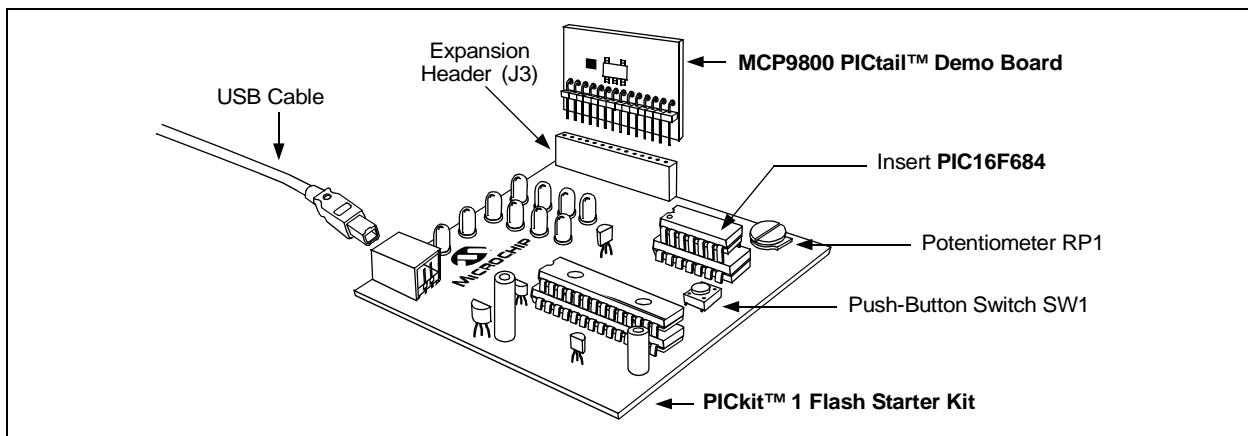

FIGURE 2-2: MCP9800 PICtail™ Daughter Board and PICkit™1 Flash Starter Kit.

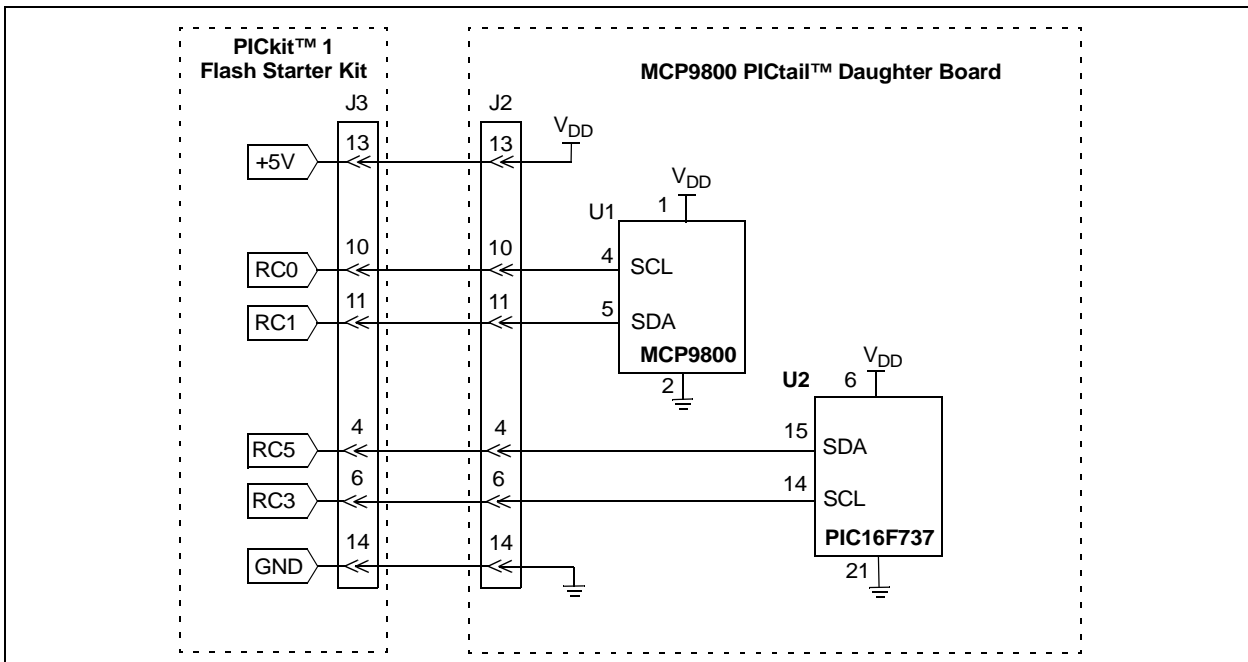

FIGURE 2-3: Simplified MCP9800 PICtail™ Daughter Board Schematic.

2.3.2 Programming the PIC16F684

1. Download and install the PICkit 1 Flash Starter Kit software onto your PC.
2. Copy the 00031R1-1.HEX file (supplied on the CD that came with this kit) onto your PC.
3. When the PICkit 1 Flash Starter Kit is started, the main window will be displayed on the PC, as indicated in Figure 2-4.

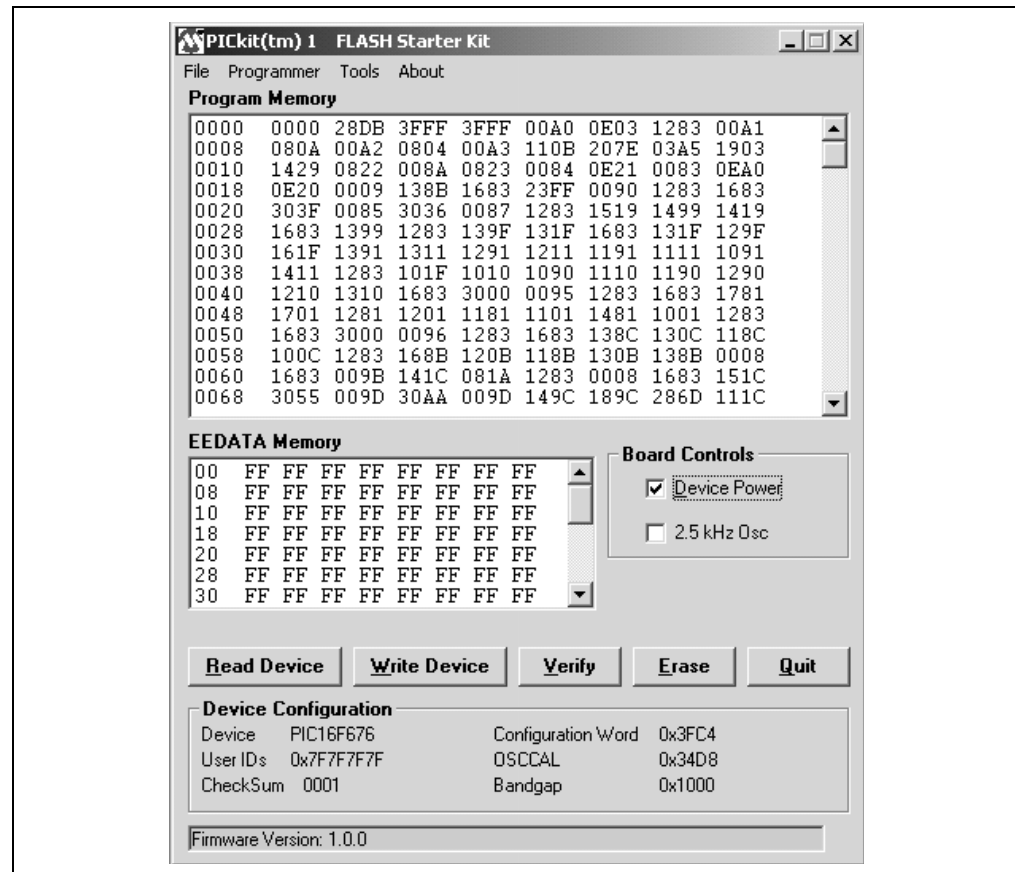

FIGURE 2-4: PICkit™ 1 Flash Starter Kit GUI Window on the PC.

4. Switch off the device power by unchecking the **Device Power** box under **Board Controls** in the PICkit 1 Flash Starter Kit window (Figure 2-4). The busy LED on the PICkit 1 Flash Starter Kit will switch off when the device power is switched off.
5. Click on the **Erase** button in the window to ensure that the PIC16F684 device has been erased.
6. From the **File** pull-down menu, select **Import HEX**. A file window will appear. Select and open 00031R1-1.HEX.
7. Click on the **Write Device** button in the PICkit 1 Flash Starter Kit window. The PIC16F684 device will be written to with the 00031R1-1.HEX firmware. Once completed, the status bar at the bottom of the window will indicate **Write Successful**.
8. Switch on the device power by checking the **Device Power** box under **Board Controls** in the PICkit 1 Flash Starter Kit window. The busy LED on the PICkit 1 Flash Starter Kit will turn on when the device power is switched on.
9. The 7-segment display on the MCP9800 Thermal Sensor PICtail Demo Board will show ambient temperature (°C).

2.4 FUNCTIONAL DESCRIPTION

2.4.1 The MCP9800 Thermal Sensor PICtail™ Demo Board

This demo board has the MCP9800 temperature sensor device and a 7-segment LED display circuit. The user can read the ambient temperature data from the MCP9800 using the PICkit 1 Flash Starter Kit and display the data using the 7-segment display on the MCP9800 Thermal Sensor PICtail Demo Board. It's also possible to transmit the data to a PC for a display using the PICkit 1 Flash Starter Kit software strip-chart display tool.

This demo board has a 14-pin header that connects to the PICkit 1 Flash Starter Kit. The header connects the +5V supply, ground and all serial I/O pins to the MCP9800 Thermal Sensor PICtail Demo Board. There are four serial I/O lines used to communicate with the MCP9800 and the 7-segment display circuit. The MCP9800 uses two I/O lines for the I²C™ interface to transmit temperature data, while the 7-segment display circuit uses two I/O lines for the SPI™ interface to display temperature data.

The user can develop custom firmware to communicate with the MCP9800 and the 7-segment display using most 14-pin PICmicro® microcontrollers and the PICkit 1 Flash Starter Kit. In addition, Microchip provides a demo firmware that uses the PIC16F684 microcontroller. This firmware will be referenced throughout the user's guide to show the various functions of the demo board.

2.4.2 The MCP9800

The MCP9800 comes with user-programmable registers that provide flexibility for temperature-sensing applications. The register settings allow user-selectable 9-bit to 12-bit temperature measurement resolution, configuration of the power-saving Shutdown and One-shot (single conversion on command while in Shutdown) modes and the specification of both temperature alert output and hysteresis limits. When the temperature changes beyond the specified limits, the MCP9800 outputs an alert signal. The user has the option of setting the alert output signal polarity as an active-low or active-high comparator output for thermostat operation, or as a temperature event interrupt output for microprocessor-based systems

This device has I²C/SMBus compatible serial interface (refer to the MCP9800 data sheet (DS21909) for further details).

2.4.3 User-Selectable Features

The demo firmware programs the Temperature Limit and Hysteresis Limit registers (T_{SET} and T_{HYST} , respectively) according to the position of the RP1 potentiometer, located on the PICkit 1 Flash Starter Kit. The potentiometer is connected to the PIC16F684 analog input pin. The voltage across the potentiometer wiper terminal determines T_{SET} . The wiper position provides 15 possible T_{SET} limits from 10°C to 55°C, in 3°C increments. T_{HYST} is programmed 5°C below T_{SET} (5°C hysteresis).

When the ambient temperature exceeds the programmed T_{SET} limit, the MCP9800 outputs an alert signal using the ALERT output pin. This pin is an open-drain output that is configured as an active-high output. When this pin is high, the D₁ diode lights up and remains lit until the temperature drifts beyond the hysteresis limit (T_{HYST}).

This firmware also converts degree Celsius to degree Fahrenheit using the SW1 switch located on the PICkit 1 Flash Starter Kit. When the user presses the momentary push-button switch, the 7-segment display shows the ambient temperature in degree Fahrenheit.

In addition, the user has the option of changing the MCP9800 temperature measurement resolution (default resolution is 10-bit). However, this requires modifying a firmware variable and recompiling the firmware. The `00031R1-1.asm` firmware can be edited and compiled using Microchip's MPLAB® IDE, which can be downloaded from Microchip's web site at www.microchip.com. This particular variable is identified in text within the firmware, with an instruction provided about how to change the variable to select a resolution. Once the variable is changed according to the instruction given in the `00031R1-1.asm` firmware, the user can recompile the firmware and program the PIC16F684 with the `00031R1-1.HEX` file, as shown in **Section 2.3.2 "Programming the PIC16F684"**.

This demo board and demo firmware provides a platform to easily develop a custom firmware and evaluate the various features of the MCP9800.

2.4.4 Displaying the Temperature Data

2.4.4.1 THE 7-SEGMENT LED DISPLAY

The PIC16F684 microcontroller firmware, located on the PICkit 1 Flash Starter Kit, reads the ambient temperature from the MCP9800 temperature sensor and sends the data to the 7-segment LED display.

The 7-segment LED display is controlled using another PICmicro® microcontroller that is located on the MCP9800 Thermal Sensor PICtail Demo Board. This PICmicro microcontroller controls the LED segments and display frequency. It receives data from the PICkit 1 Flash Starter Kit using ports RC3 and RC5 via the SPI protocol. Once the data is successfully received, the PICmicro microcontroller displays the corresponding LED segments.

The temperature data from the PICkit 1 Flash Starter Kit has to be formatted to Binary Code Decimal (BCD) before transmission. A 4-bit instruction and a 4-bit BCD has to be transmitted for each of the four digits on the 7-segment display. The location and definition of the instruction bits and BCD bits are shown in Table 2-1.

TABLE 2-1: SERIAL DATA FORMAT

Instruction				BCD	
Start	Dot	No display	Dash	MSb	LSb
bit 7					bit 0

- bit 7 **START:** Start-of-display bit
 1 = This BCD is the first digit
 0 = This BCD is not the first digit
- bit 6 **DOT:** Display dot bit
 1 = Display dot after this BCD, which indicates that the next BCD is a decimal point
 0 = No dot displayed
- bit 5 **NO DISPLAY:** No digit to be displayed
 1 = Digit not displayed
 0 = Digit displayed
- bit 4 **DASH:** Display dash for negative number bit
 1 = Display dash (—) to indicate negative number.
 0 = Dash not displayed
- bit 3 - 0 **BCD:** BCD bits MSb first

This format requires that a 32-bit data (8 bits at a time) needs to be transmitted in order to display four-digit temperature data on the 7-segment display.

Table 2-2 shows examples on displaying temperature data.

TABLE 2-2: TEMPERATURE DATA FORMAT FOR DISPLAY

Temperature	1 st byte	2 nd byte	3 rd byte	4 th byte
125.5	1000 0001	0000 0010	0100 0101	0000 0101
25.25	1000 0010	0100 0101	0000 0010	0000 0101
5.25	1010 0000	0100 0101	0000 0010	0000 0101
-5.25	1001 0000	0100 0101	0000 0010	0000 0101
-55.5	1001 0000	0000 0101	0100 0101	0000 0101

This format insures proper protocol between the microcontrollers on the PICkit 1 Flash Starter Kit and the MCP9800 Thermal Sensor PICtail Demo Board. In addition, this display protocol makes the 7-segment display circuit generic for use in applications other than temperature data display.

The 7-segment display controller firmware (00031R1-2.HEX) can be customized using Microchip's MPLAB® ICD 2 programming tool. A header can be soldered on the MCP9800 Thermal Sensor PICtail Demo Board for the MPLAB ICD 2 programmer. The PIC16F737 microcontroller cannot be programmed using the PICKit 1 Flash Starter Kit.

2.4.4.2 STRIP-CHART DISPLAY ON PC

Once the hardware is connected to the PICKit 1 Flash Starter Kit, as shown in **Section 2.3.1 “Hardware Setup”**, and the PIC16F684 MCU is programmed as indicated in **Section 2.3.2 “Programming the PIC16F684”**, the user can use the strip-chart tool available on the PICKit 1 Flash Starter Kit software. This is done by selecting the strip-chart tool on the software and clicking **GO**.

The strip-chart display shows the ambient temperature data from the MCP9800. This display does not support negative numbers. Therefore, the data is offset by 1024. In addition, the tool does not support 11-bit and 12-bit data.

NOTES:



MCP9800 THERMAL SENSOR PICtail™ DEMO BOARD USER'S GUIDE

Appendix A. Schematic and Layouts

A.1 INTRODUCTION

This appendix contains the following schematics and layouts for the MCP9800 Thermal Sensor PICtail Demo Board:

- Board Schematic
- Board - Top Layer
- Board - Silk-Screen Layer
- Board - Bottom Layer

A.2 BOARD SCHEMATIC

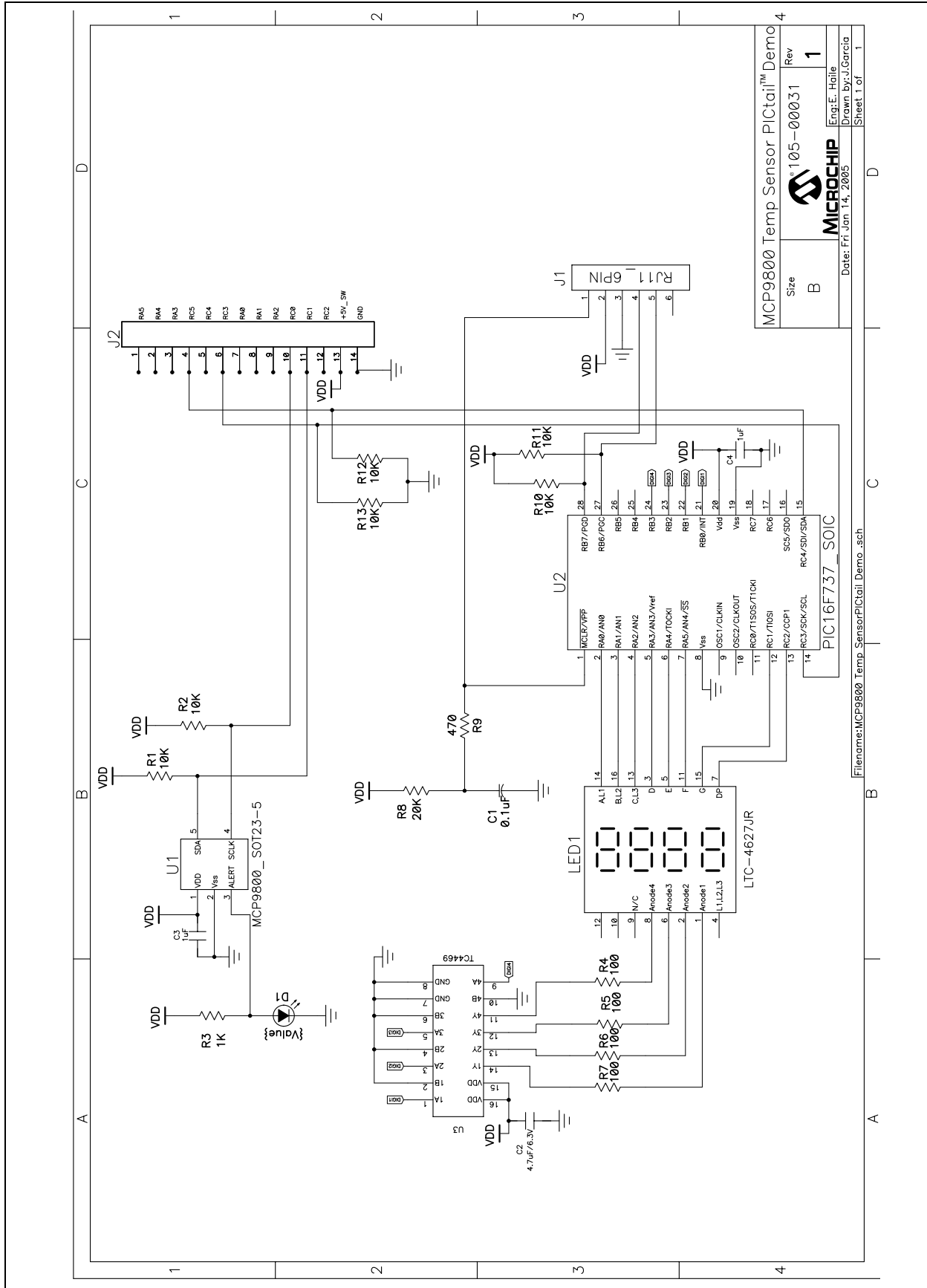

A.3 BOARD - TOP LAYER

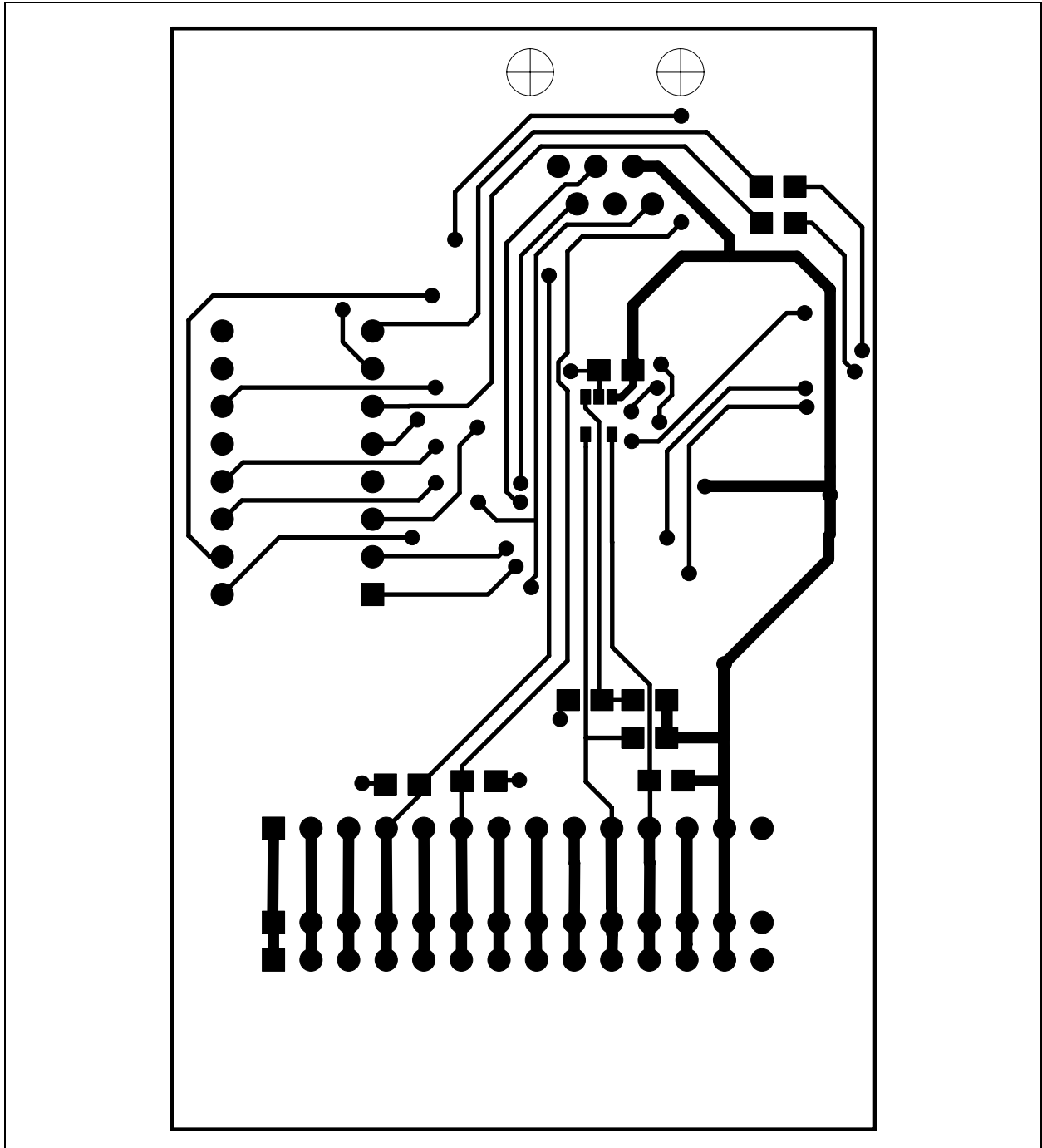

A.4 BOARD - SILK-SCREEN LAYER

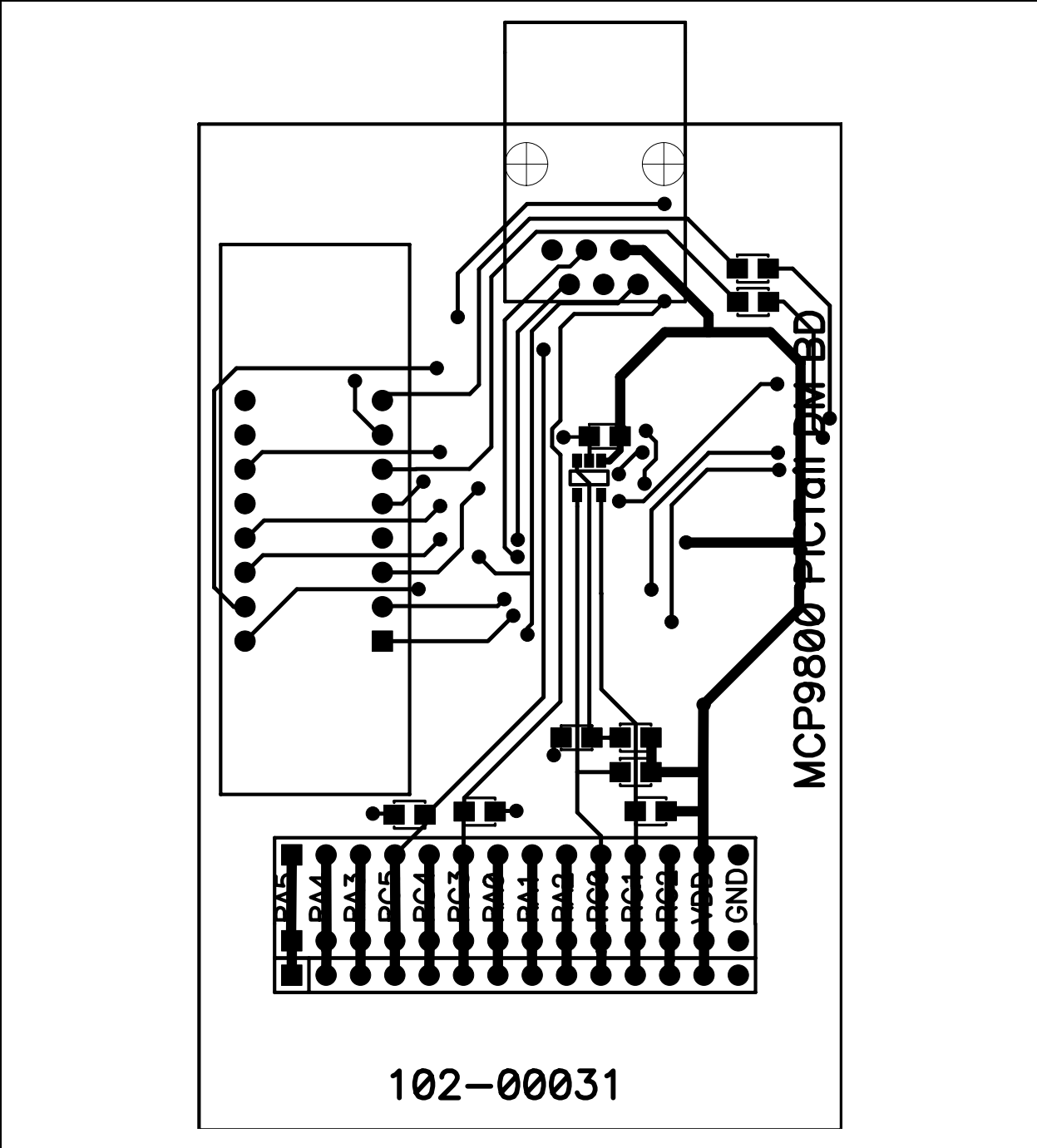

A.5 BOARD - BOTTOM LAYER

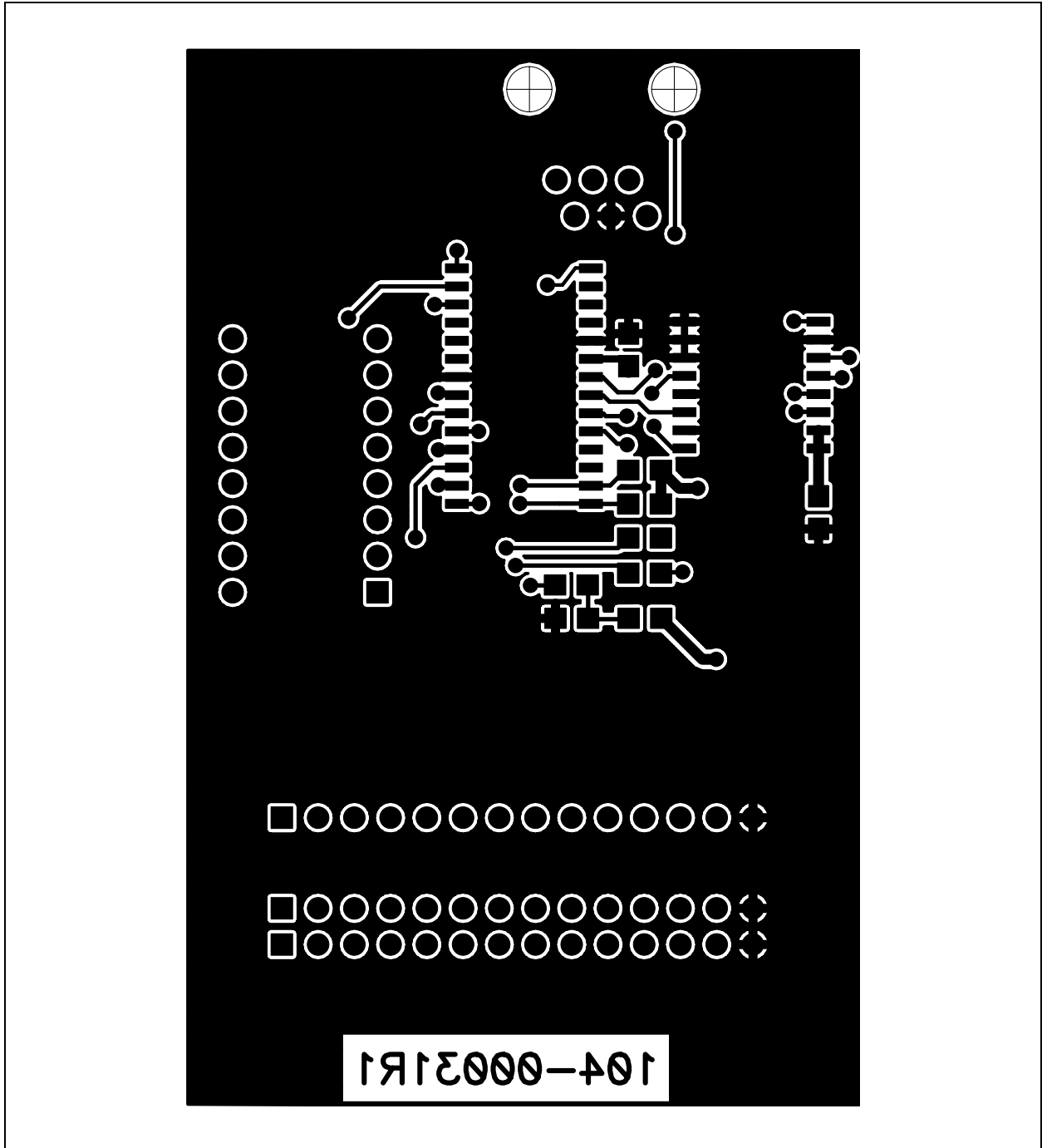

NOTES:



MCP9800 THERMAL SENSOR PICtail™ DEMO BOARD USER'S GUIDE

Appendix B. Bill-Of-Materials (BOM)

TABLE B-1: BILL-OF-MATERIALS (BOM)

Qty	Reference	Description	Manufacturer	Part Number
1	C1	CAP .1 μ F 16V CERAMIC X7R 0805	Panasonic® - ECG	ECJ-2VB1C104K
1	C2	CAP 4.7 μ F 6.3V CERAMIC 0805 X5R	Panasonic - ECG	ECJ-2FB0J475M
2	C3,C4	CAP 1 μ F 16V CERAMIC Y5V 0805	Panasonic - ECG	ECJ-2VF1C105Z
1	D1	LED 2.8X3.2 MM 635NM RED CLR SMD	Panasonic - ECG	SML-LX2832IC-TR
1	LED1	LED 7-Segment .4" 4DGT SUPER RED CA	Panasonic - ECG	LTC-4627JR
1	R3	RES 1.00 K Ω 1/10W 1% 0805 SMD	Panasonic - ECG	ERJ-6ENF1001V
6	R1,R2,R10, R11,R12,R13	RES 10.0 K Ω 1/10W 1% 0805 SMD	Panasonic - ECG	ERJ-6ENF1002V
1	R8	RES 20.0 K Ω 1/10W 1% 0805 SMD	Panasonic - ECG	ERJ-6ENF2002V
5	R3,R4,R5,R6 R7	RES 100 Ω 1/10W 1% 0805 SMD	Panasonic - ECG	ERJ-6ENF1000V
1	R9	RES 475 Ω 1/10W 1% 0805 SMD	Panasonic - ECG	ERJ-6ENF4750V
1	J1	CONNMODJACK6-6R/APCB50AU * * Note: "NOT POPULATED"	Panasonic - ECG	520470-3
1	J2	CONN HEADER 14POS .100 VERT TIN	Panasonic - ECG	22-28-4140
	U1	2-Wire High-Accuracy Temperature Sensor	Microchip Technology Inc.	MCP9800AOT-M/TOG
	U2	8-Bit CMOS Flash Microcontroller	Microchip Technology Inc.	PIC16F737-I/SO
	U3	Logic-Input CMOS Quad Drivers	Microchip Technology Inc.	TC4469COE



WORLDWIDE SALES AND SERVICE

AMERICAS

Corporate Office
2355 West Chandler Blvd.
Chandler, AZ 85224-6199
Tel: 480-792-7200
Fax: 480-792-7277
Technical Support:
<http://support.microchip.com>
Web Address:
www.microchip.com

Atlanta
Alpharetta, GA
Tel: 770-640-0034
Fax: 770-640-0307

Boston
Westford, MA
Tel: 978-692-3848
Fax: 978-692-3821

Chicago
Itasca, IL
Tel: 630-285-0071
Fax: 630-285-0075

Dallas
Addison, TX
Tel: 972-818-7423
Fax: 972-818-2924

Detroit
Farmington Hills, MI
Tel: 248-538-2250
Fax: 248-538-2260

Kokomo
Kokomo, IN
Tel: 765-864-8360
Fax: 765-864-8387

Los Angeles
Mission Viejo, CA
Tel: 949-462-9523
Fax: 949-462-9608

San Jose
Mountain View, CA
Tel: 650-215-1444
Fax: 650-961-0286

Toronto
Mississauga, Ontario,
Canada
Tel: 905-673-0699
Fax: 905-673-6509

ASIA/PACIFIC

Australia - Sydney
Tel: 61-2-9868-6733
Fax: 61-2-9868-6755

China - Beijing
Tel: 86-10-8528-2100
Fax: 86-10-8528-2104

China - Chengdu
Tel: 86-28-8676-6200
Fax: 86-28-8676-6599

China - Fuzhou
Tel: 86-591-8750-3506
Fax: 86-591-8750-3521

China - Hong Kong SAR
Tel: 852-2401-1200
Fax: 852-2401-3431

China - Shanghai
Tel: 86-21-5407-5533
Fax: 86-21-5407-5066

China - Shenyang
Tel: 86-24-2334-2829
Fax: 86-24-2334-2393

China - Shenzhen
Tel: 86-755-8203-2660
Fax: 86-755-8203-1760

China - Shunde
Tel: 86-757-2839-5507
Fax: 86-757-2839-5571

China - Qingdao
Tel: 86-532-502-7355
Fax: 86-532-502-7205

ASIA/PACIFIC

India - Bangalore
Tel: 91-80-2229-0061
Fax: 91-80-2229-0062

India - New Delhi
Tel: 91-11-5160-8631
Fax: 91-11-5160-8632

Japan - Kanagawa
Tel: 81-45-471- 6166
Fax: 81-45-471-6122

Korea - Seoul
Tel: 82-2-554-7200
Fax: 82-2-558-5932 or
82-2-558-5934

Singapore
Tel: 65-6334-8870
Fax: 65-6334-8850

Taiwan - Kaohsiung
Tel: 886-7-536-4818
Fax: 886-7-536-4803

Taiwan - Taipei
Tel: 886-2-2500-6610
Fax: 886-2-2508-0102

Taiwan - Hsinchu
Tel: 886-3-572-9526
Fax: 886-3-572-6459

EUROPE

Austria - Weis
Tel: 43-7242-2244-399
Fax: 43-7242-2244-393

Denmark - Ballerup
Tel: 45-4450-2828
Fax: 45-4485-2829

France - Massy
Tel: 33-1-69-53-63-20
Fax: 33-1-69-30-90-79

Germany - Ismaning
Tel: 49-89-627-144-0
Fax: 49-89-627-144-44

Italy - Milan
Tel: 39-0331-742611
Fax: 39-0331-466781

Netherlands - Drunen
Tel: 31-416-690399
Fax: 31-416-690340

England - Berkshire
Tel: 44-118-921-5869
Fax: 44-118-921-5820