

Digilent PmodDA1™ Digital To Analog Module Converter Board Reference Manual

Revision: 04/12/05



215 E Main Suite D | Pullman, WA 99163
(509) 334 6306 Voice and Fax

Overview

The Digilent PmodAD1 Digital to Analog Module Converter module (the DA1™) converts signals from digital to analog at up to one MSa per second. The DA1 uses a 6-pin header connector and at less than one square inch is small enough to be located where the reconstructed signal is needed.

Features include:

- two AD7303 8-bit D/A converter chips that convert up to one MSa per second
- a 6-pin header and 6-pin connector
- four D/A conversion channels
- very low power consumption
- small form factor (0.80" x 0.80").

Functional Description

The DA1 can produce an analog output ranging from 0-3.3 volts. It has four simultaneous D/A conversion channels, each with an 8-bit converter that can process separate digital signals.

The DA1 is equipped with two AD7303 digital to analog converters. Each converter has two channels through which digital signals can be converted to analog signals.

Outputs are produced by sending commands via the SPI/MICROWIRE™ serial bus to the D/A converters. The two converters are connected in parallel so that commands are sent to both converters simultaneously.

The DA1 is designed to work with Digilent system boards. Some system boards, like the Digilent Pegasus board, have a 6-pin header that can be connected to the DA1's 6-pin header using a 6-pin cable.

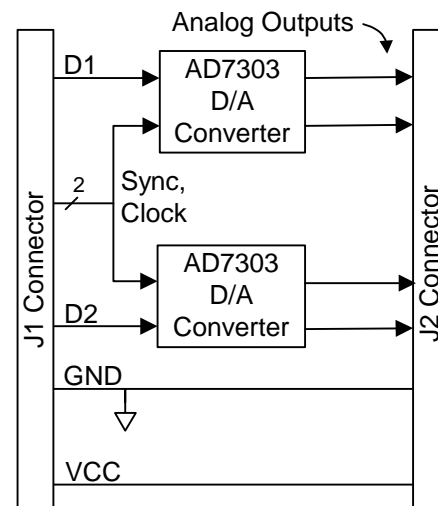
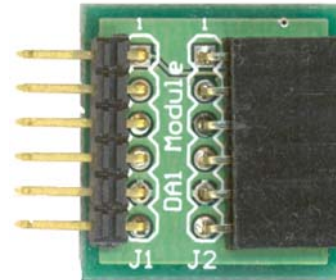

DA1 Circuit Diagram

Other Digilent boards may need a Digilent Modular Interface Board (MIB) and a 6-pin cable to connect to the DA1. The MIB plugs into the system board and the cable connects the MIB to the DA1.

The DA1 can be powered by voltage from either a Digilent system board or an outside device. Damage can result if power is supplied from both sources or if the outside device supplies more than 3V. For more information, see www.digilentinc.com.

For information on the AD7303, see the Analog Devices data sheet at www.analog.com.