

Toggle Switches



Specifications:

Electrical:

Maximum contact rating : Gold : 0.4 VA at 20 V (ac or dc)
 Maximum contact resistance : 10 mΩ
 Minimum insulation resistance : 1,000 MΩ at 500 V dc
 Dielectric strength : 1,000 V rms

Mechanical:

Life : 40,000 Cycles

Environmental:

Operating temperature : -30°C to +85°C

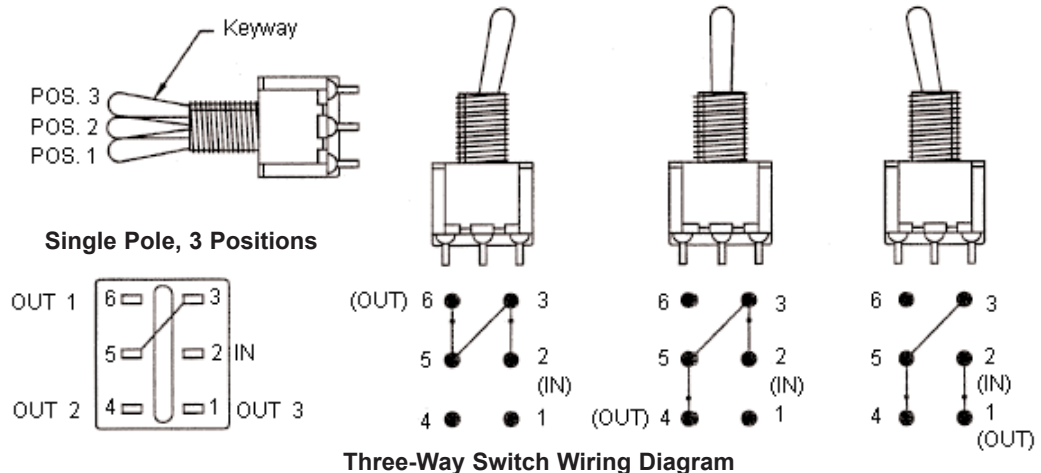
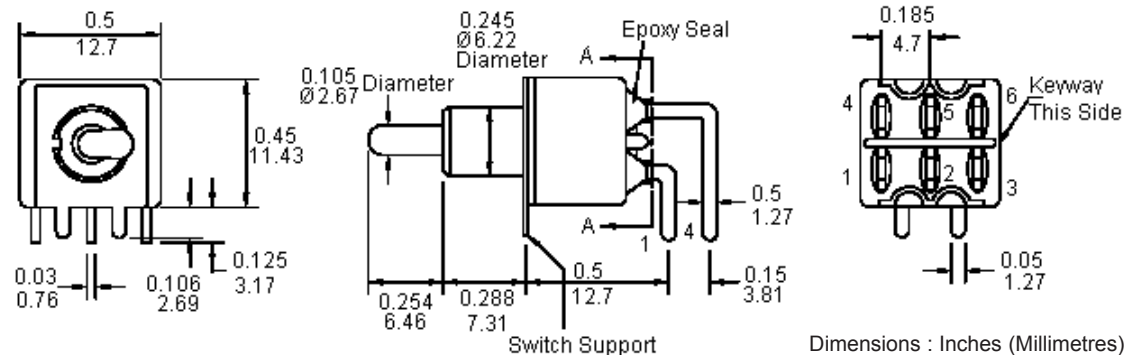

Material:

Case : DAP
 Housing : Stainless steel
 Actuator : Brass, chrome plated
 Bushing : Brass, nickel plated
 Support : Brass, tin plated
 Contact / Terminals : Copper alloy, gold plated



Toggle Switches



Model No.	Switching Position		
			
SPC21216	ON	ON	ON
SPC21217	MOM	ON	MOM
SPC21218	ON	ON	MOM
Conn. Terms	2-3 5-6	2-3 5-4	2-1 5-4

PCB Layout Component Side (Tolerance = ±0.1)

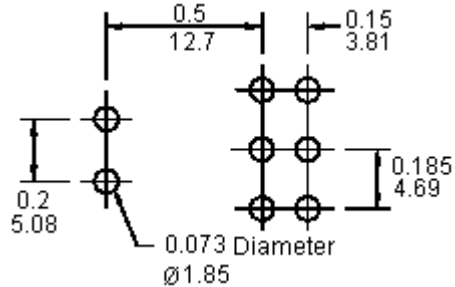

Dimensions : Inches (Millimetres)

Actuator

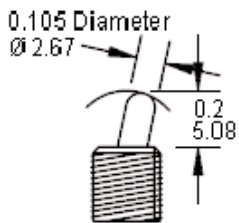

Bushing

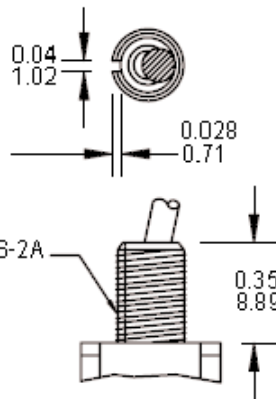

Standard Nut

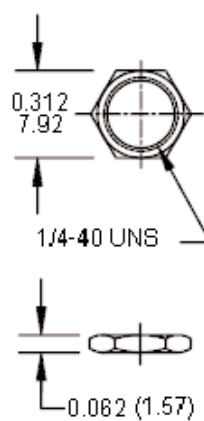

Lock Washer

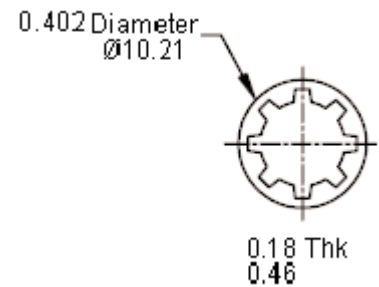

Dimensions : Inches (Millimetres)

Locking Ring

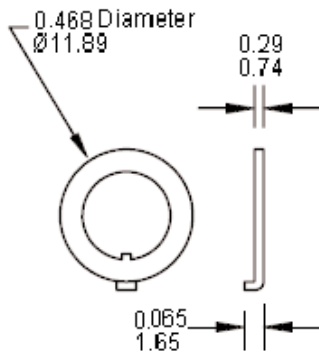

Panel Mounting

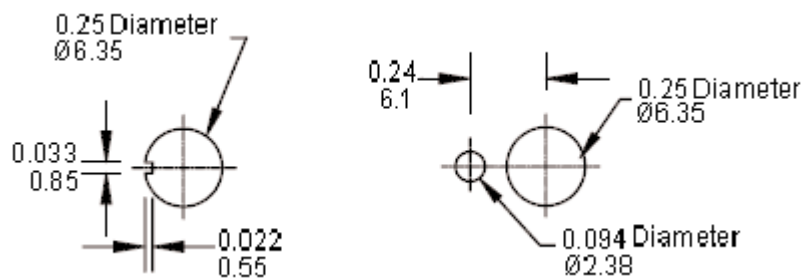

Dimensions : Inches (Millimetres)

Part Number Table

Description	Part Number
Toggle Switch	SPC21216
Toggle Switch	SPC21217
Toggle Switch	SPC21218

Disclaimer This data sheet and its contents (the "Information") belong to the Premier Farnell Group (the "Group") or are licensed to it. No licence is granted for the use of it other than for information purposes in connection with the products to which it relates. No licence of any intellectual property rights is granted. The Information is subject to change without notice and replaces all data sheets previously supplied. The Information supplied is believed to be accurate but the Group assumes no responsibility for its accuracy or completeness, any error in or omission from it or for any use made of it. Users of this data sheet should check for themselves the Information and the suitability of the products for their purpose and not make any assumptions based on information included or omitted. Liability for loss or damage resulting from any reliance on the Information or use of it (including liability resulting from negligence or where the Group was aware of the possibility of such loss or damage arising) is excluded. This will not operate to limit or restrict the Group's liability for death or personal injury resulting from its negligence. SPC Multicomp is the registered trademark of the Group. © Premier Farnell plc 2011.

<http://www.farnell.com>
<http://www.newark.com>
<http://www.cpc.co.uk>

