

Front Mount Hole Cutters



Features:

- One of a range of 'D' connector hole cutters in industry standard sizes, to be used by hand
- Designed to punch burr-free holes in up to 1.6 mm thick mild steel and up to 2.0 mm thick aluminium
- The punch and die are case hardened and tempered. All items are finished chemically blacked, and are machined to close tolerances

Specifications:

Materials:

Screw, 5/6"	: Mild steel
Die 1	: Mild steel
Die 2	: Mild steel
Guide plate	: Mild steel
Drilling jig	: Mild steel
Thrust race	: Mild steel
Washer, 5/16"	: Mild steel
Special nut	: Mild steel

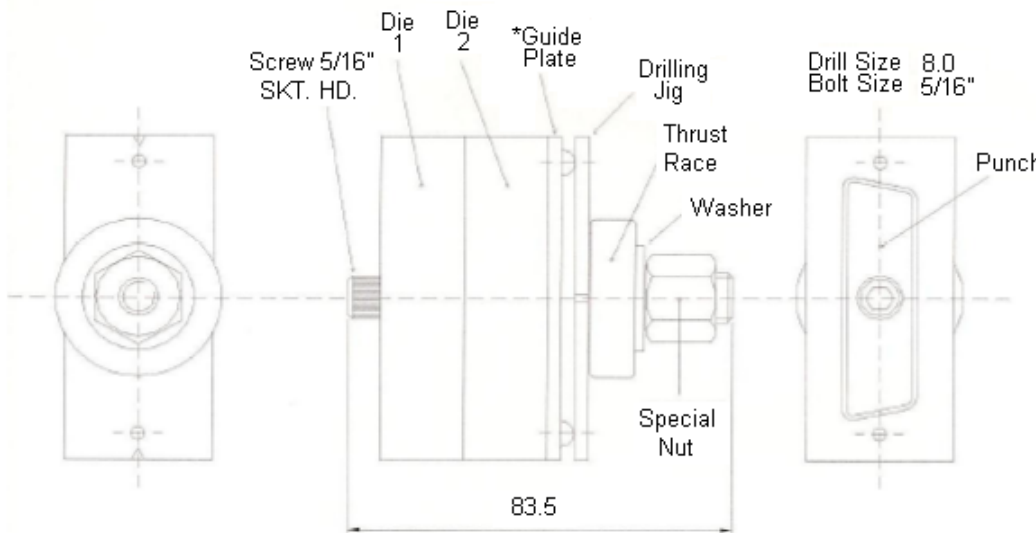

Dimensions : Millimetres

Specification Table

Description	Type	Order Code	
		Front Set	Rear Set
Front Mount D Hole Cutter	9 Way	975-0010	975-0010
Front Mount D Hole Cutter	15 Way	975-0020	975-0020
Front Mount D Hole Cutter	25 Way	975-0030	975-0030
Front Mount D Hole Cutter	37 Way	975-0040	975-0040

*No guide plate on 9 way or 15 way sets.

Important Notice : This data sheet and its contents (the "Information") belong to the members of the Premier Farnell group of companies (the "Group") or are licensed to it. No licence is granted for the use of it other than for information purposes in connection with the products to which it relates. No licence of any intellectual property rights is granted. The Information is subject to change without notice and replaces all data sheets previously supplied. The Information supplied is believed to be accurate but the Group assumes no responsibility for its accuracy or completeness, any error in or omission from it or for any use made of it. Users of this data sheet should check for themselves the Information and the suitability of the products for their purpose and not make any assumptions based on information included or omitted. Liability for loss or damage resulting from any reliance on the Information or use of it (including liability resulting from negligence or where the Group was aware of the possibility of such loss or damage arising) is excluded. This will not operate to limit or restrict the Group's liability for death or personal injury resulting from its negligence. DURATOOL is the registered trademark of the Group. © Premier Farnell plc 2011.

