

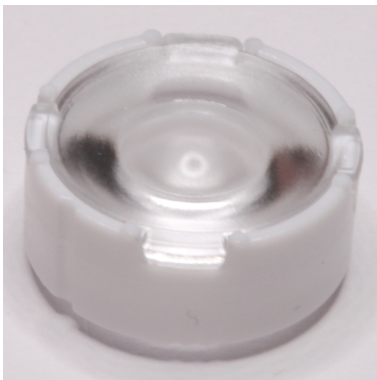

Ordering number FA11905
Description FA11905_Tina3-S-XM

Family Tina3
 Type Lens
 LED XM-L
 Color White
 Diameter 16.1 mm
 Height 11.35 mm
 Style Round
 Optic Material PMMA
 Holder Material PC
 Fastening Pin, tape
 Status Ready

FWHM 23 degrees
 Efficiency 86 %
 cd/lm -
 Gerber File Available



Ordering number FA11902
Description FA11902_Tina3-W-XM

Family Tina3
 Type Lens
 LED XM-L
 Color White
 Diameter 16.1 mm
 Height 7.95 mm
 Style Round
 Optic Material PMMA
 Holder Material PC
 Fastening Pin, tape
 Status Ready

FWHM 37 degrees
 Efficiency 92 %
 cd/lm -
 Gerber File Available

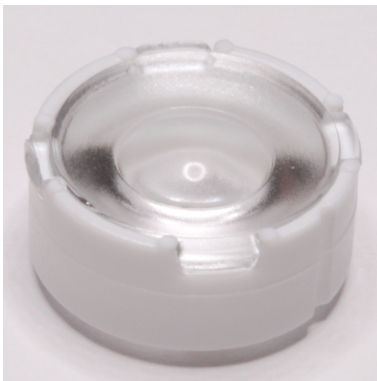

Ordering number FA11903
Description FA11903_Tina3-WW-XM

Family Tina3
 Type Lens
 LED XM-L
 Color White
 Diameter 16.1 mm
 Height 7.1 mm
 Style Round
 Optic Material PMMA
 Holder Material PC
 Fastening Pin, tape
 Status Ready

FWHM 56 degrees
 Efficiency 89 %
 cd/lm -
 Gerber File Available



Ordering number FA11904
Description FA11904_Tina3-WWW-XM

Family Tina3
 Type Lens
 LED XM-L
 Color White
 Diameter 16.1 mm
 Height 6.9 mm
 Style Round
 Optic Material PMMA
 Holder Material PC
 Fastening Pin, tape
 Status Ready

FWHM 71 degrees
 Efficiency 88 %
 cd/lm -
 Gerber File Available



PRODUCT DATASHEET Tina3-XM series



NOTE: The typical divergence will be changed by different color, chip size and chip position tolerance. The typical total divergence is the full angle measured where the luminous intensity is half of the peak value.



PRODUCT DATASHEET Tina3-XM series



GENERAL INFORMATION

- Product series especially designed & optimized for XM-L series of LEDs.
- Special care taken to make light distribution as uniform as possible.
- Lens material optical grade PMMA with high UV and temperature resistance (105 degrees of Celcius / 220 degrees of Fahrenheit). Allows use of high current and temperature conditions.

Please find more information about used material from below:

http://ledil.fi/sites/default/files/Documents/Technical/Material/PMMA%20N%20UL94_Yellow%20Card.pdf

<http://ledil.fi/sites/default/files/Documents/Technical/Material/PMMA%20N%20PLEXIGLAS-Datasheet.pdf>

- Optic holder molded by high quality PC material (120 dergees of Celcius / 248 degrees of Fahrenheit).

- Fastening to heat sink with a PU foam adhesive tape of automotive grade. Please find fastening details by clicking link: http://www.ledil.com/datasheets/DataSheet_TAPE.pdf

NOTE 1: We advise customer to ensure the suitability and sufficiency of the bond in the end product. For example, mechanical stress, vibration and holes on the surface of the circuit board weaken the strength of the tape.

NOTE 2: Assembly to the surface must be made straight, so the tape bonds constant and balanced with fastening surface. Slanted assembly might cause unbalanced bond to the surface. All surfaces where tape is applied must be clean, dry and free from grease and dirt.

If cleaning of PCB surfaces is needed, please follow strictly the cleaning instructions of your LED manufacturer - this is important as cleaning shall under no circumstances damage LEDs or other electronics components on the PCB.

Further note that optical components shall not be cleaned with any chemicals - only micro fiber cloth may be used to remove fingerprints or other traces from handling.

D

C

B

A

4

4

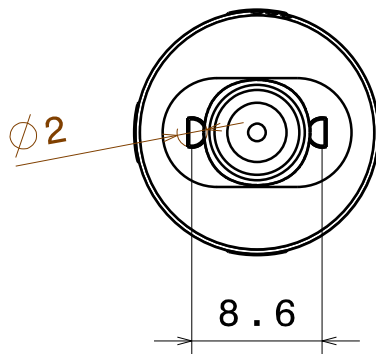

3

3

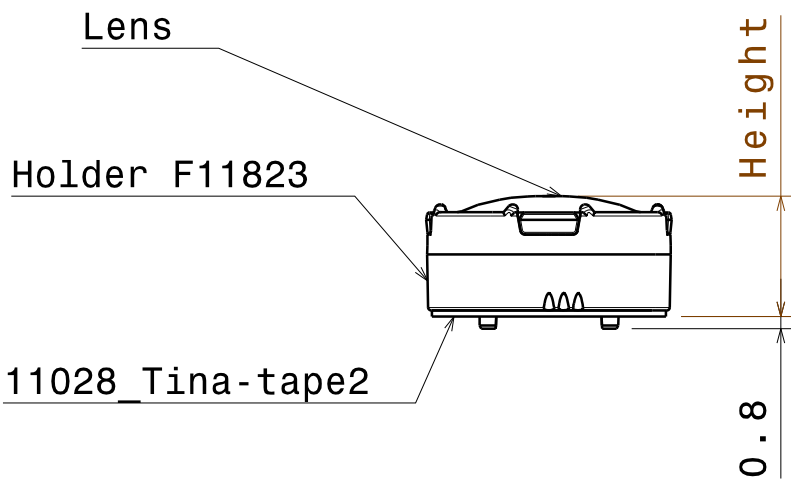

Height:
S:11.36
W:7.95
WW:7.1
WWW:6.9

2

2

MATERIALS
Lens: PMMA
Holder: PC
Tape: PU Foam

Part no.s:
FA11905_Tina3-S-XM
FA11902_Tina3-W-XM
FA11903_Tina3-WW-XM
FA11904_Tina3-WWW-XM

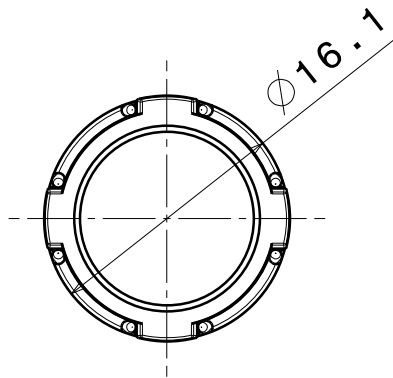

This drawing is our property.
It can't be reproduced
or communicated without
our written agreement.



Ledil Oy
Tehdaskatu 13
FIN-24100 SALO
Finland

DRAWING TITLE

Datasheet Tina3-series Assy XM

DRAWN BY
ah

DATE
18.05.2011

CHECKED BY
ah

DATE
18.5.2011

SIZE
A4

DRAWING NUMBER

-

REV
1

DESIGNED BY
pv

DATE
13.10.2010

SCALE

2:1

WEIGHT (g)

-

SHEET

1/1

D

A

1

1