

## AND64C402V-HB-KIT

6.4" VGA

Color TFT LCD Module

The AND64C402V-HB-KIT is a compact full color amorphous silicon TFT LCD module, that is suitable for applications such as computers, industrial, and test equipment. This device consists of a twisted nematic (TN) liquid crystal cell, that incorporates a TFT-array that has 640 x 480 pixels on a 6.4 inch diagonal screen, X and Y drivers, an LSI controller, and a built-in CCFL backlight.

### Features

- High aperture ratio
- High brightness
- Wide view angle
- High contrast ratio
- Pixel in stripe configuration
- Image Reversion: Up/Down & Left/Right
- Backlight lamps are replaceable
- Compatible w/VGA-480, VGA-400, VGA-350 & free format
- Single 5V input for LCD
- Thin and light weight
- High image quality
- Digital input

Product specifications contained herein may be changed without prior notice. It is therefore advisable to contact Purdy Electronics before proceeding with the design of equipment incorporating this product.

### Mechanical Characteristics

Item	Specification	Unit
Screen Size	6.4 inch (17 cm) diagonal	inch
Outline Dimensions	175.0 (H) x 126.5 (V) x 12.5 (D)	mm
Active Area	129.60 x 97.44	mm
Input Signal	6-bit Digital	
Pixel No. (RGB trio)	640 (H) x 480 (V)	–
Sub Pixel No.	1920 (H) x 480 (V)	–
Sub Pixel Arrangement	Stripe	–
Pixel Pitch	0.203 (H) x 0.203 (V)	mm
Weight	335	g

### Absolute Maximum Rating

Item	Symbol	Conditions	Absolute Max. Rating		Unit
			Min.	Max.	
+5V Supply Voltage	$V_{CC}$	$T_a=25^{\circ}\text{C}$	0.0	6.0	V
Input Signals Voltage	$V_{sig}$	$T_a=25^{\circ}\text{C}$	-0.3	$V_{CC}+0.3$	V
Operating Temperature	$T_{op}$	–	0	+55	$^{\circ}\text{C}$
Storage Temperature	$T_{stg}$	–	-25	+70	$^{\circ}\text{C}$
Humidity (No condensation of water)	–	$\leq 40^{\circ}\text{C}$	–	95%	RH

### Electrical Specification

Item	Symbol	Conditions	Specifications			Units
			Min.	Typ.	Max.	
Supply Voltage	$V_{CC}$	$T_a=25^{\circ}\text{C}$	4.75	5.0	5.25	V
Current Dissipation	$I_{CC}$	$T_a=25^{\circ}\text{C}$	–	500	600	mA
Supply Input Ripple Voltage	$V_{CCRP}$	$T_a=25^{\circ}\text{C}$	–	–	0.1	Vp-p
Input Signals Voltage (High)	$V_{IH}$	$T_a=25^{\circ}\text{C}$	2.6	–	–	V
Input Signals Voltage (Low)	$V_{IL}$	$T_a=25^{\circ}\text{C}$	–	–	0.5	V
Input Signals Current (High)	$I_{IH}$	$T_a=25^{\circ}\text{C}$	–	–	100	$\mu\text{A}$
Input Signals Current (Low)	$I_{IL}$	$T_a=25^{\circ}\text{C}$	–	–	100	$\mu\text{A}$

( $T_a = RT$ )

**Power Consumption**

Parameters	Symbol	Specifications		Unit	Remark
		Typ.	Max.		
+5V Current Dissipation	$I_{CC}$	260	300	mA	–
Input Signals Current (High)	$I_{IH}$	–	100	$\mu A$	$V_{IH}=+5$
Input Signals Current (Low)	$I_{IL}$	–	100	$\mu A$	$V_{IL}=0V$
LCD Panel Power Consumption	–	1.3	–	W	–
Backlight Power Consumption	–	4.56	–	mA	$380 V_{RMS}$

**Optical Specification**

Item	Symbol	Conditions	Specifications			Unit	
			Min.	Typ.	Max.		
Luminance	LUM		–	300	–	cd/m <sup>2</sup>	
Contrast Ratio	CR	$\frac{\text{Luminance when LCD is White}}{\text{Luminance when LCD is Black}}$	100	120	–	–	
Reflectance	R		–	6.0	–	%	
Viewing Angle	Horizontal	$\theta$	CR $\geq$ 10	$\pm 45$	$\pm 55$	–	deg
	Vertical	$\theta$ (to 12 o'clock)		10	15	–	2
		$\theta$ (to 6 o'clock)		30	35	–	–
Lamp Life	+25°C	Time	–	20,000	–	hr	

**Interface Pin Assignment**
**CN1 Input Signal (DF9-318-1V)**

Pin No.	Symbol	Function
1	GND	Ground (0V)
2	CLK	Clock sig. for sampling image digital data
3	Hsync	Horizontal synchronous signal
4	Vsync	Vertical synchronous signal
5	GND	Ground (0V)
6	R0	Red Image data signal (LSB)
7	R1	Red Image data signal
8	R2	Red Image data signal
9	R3	Red Image data signal
10	R4	Red Image data signal
11	R5	Red Image data signal (MSB)
12	GND	Ground (0V)
13	G0	Green Image data signal (LSB)
14	G1	Green Image data signal
15	G2	Green Image data signal
16	G3	Green Image data signal

Pin No.	Symbol	Function
17	G4	Green Image data signal
18	G5	Green Image data signal (MSB)
19	GND	Ground (0V)
20	B0	Blue Image data signal (LSB)
21	B1	Blue Image data signal
22	B2	Blue Image data signal
23	B3	Blue Image data signal
24	B4	Blue Image data signal
25	B5	Blue Image data signal (MSB)
26	GND	Ground (0V)
27	DENB	Signal to select horiz. display position
28	VCC	DC +5.0V power supply
29	VCC	DC +5.0V power supply
30	R/L	Horiz. image shift-direction select signal
31	U/D	Vert. image shift-direction select signal

**CN2 & CN3 CCFL Power Supply**

Pin No.	Symbol	Description
1	VL	Input (High Voltage)
2	NC	No Connect
3	GL	Input (Low Voltage)

Note: Low voltage side of backlight inverter connects with ground of inverter circuits.

**Input/Output Connector**

(A) LCD module connector  
Hirose DF9A-31P-1V

(B) Backlight connector  
JST BHR-03VS-1  
Pin No.: 3  
Pitch: 4 mm  
Red: High voltage  
White: Low voltage

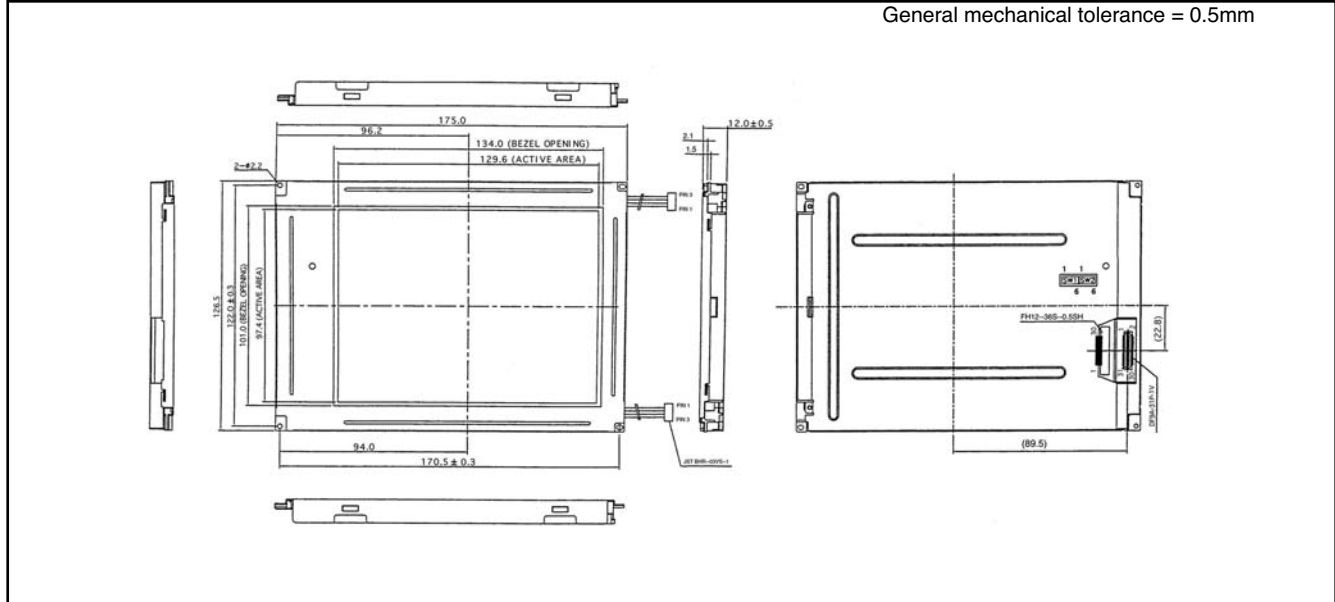
**Dimensional Outline**

Note: The TFT-LCD module is compatible with four kinds of VGA timing. They are VGA-480, VGA-400, VGA-350 and freedom mode. The polarization of Hsync and Vsync determine the timing.

	VGA-480	VGA-400	VGA-350	Freedom Mode
<b>Hsync Polarization</b>	Negative	Negative	Positive	Positive
<b>Vsync Polarization</b>	Negative	Positive	Negative	Positive

R/L is the Right/Left shift signal. The default value of the system is High.

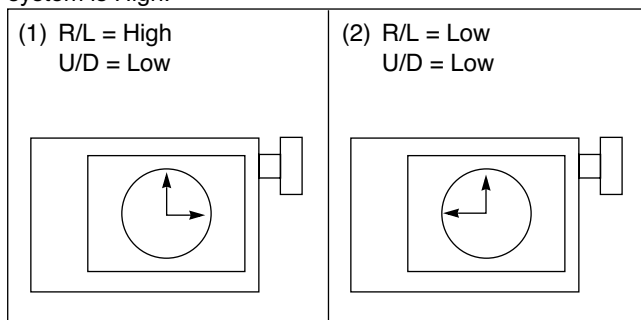

U/D is the Up/Down shift signal. The default value of the system is High.

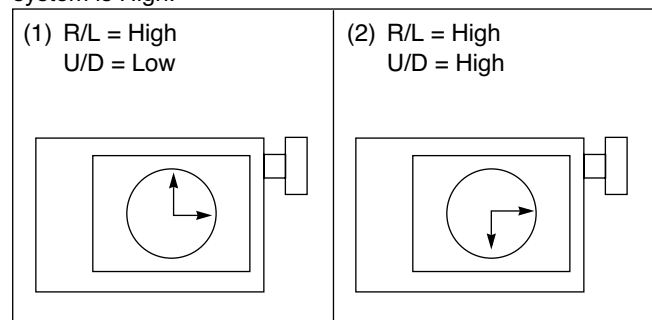
**Input/Output Signal Timing Chart**

Parameters		Symbol	Format	Min	Typ	Max	Unit
Clock	Frequency	$F_c=1/T_c$	All	–	25.175	–	MHz
	High Time	Tckh	All	10	–	–	ns
	Low Time	Tckl	All	10	–	–	ns

Parameters		Symbol	Format	Min	Typ	Max	Unit
Hsync	Periodic = Line	Thp	All	–	31.778	–	µs
				–	800	1024	clock
	Pulse Width	Thpw	All	2	96	200	clock
	Back Porch	Thbp	All	2	48	64	clock
Vsync	Periodic = Frame	Typ	VGA-480	515	525	1024	line
			VGA-400	447	449	1024	line
			VGA-350	447	449	1024	line
			Freedom Mode	–	–	1024	line
	Pulse Width	Typw	All	1	2	–	line
	Back Porch	Tybp	All	1	–	64	line
Data	Setup Time	Tds	All	10	–	–	ns
	Hold Time	Tdh	All	10	–	–	ns
DENB	Periodic = Line	Tep	All	–	800	1024	clock
				Pulse Width (H)	Tepw	All	2
	Display Line No (V)	Tvd	VGA-480	480	480	–	line
			VGA-400	400	400	–	line
			VGA-350	350	350	–	line
	Freedom Mode	–	480	–	line		
Horizontal Display Periodic		Thd	All	640	640	640	clock
Hsync-CLK Phase Difference		Thc	All	10	–	Tc-10	ns
Vsync-Hsync Phase Difference		Tvh	All	1	–	Thp-1	clock

**AND64C402V-HB Block Diagram**
