

SIEMENS

LOGO!

Manual

This manual has
the order number:
6ED1050-1AA00-0BE6

Edition 02/2005

A5E00380835-01

Preface, Contents	
Getting started with LOGO!	1
LOGO! installation and wiring	2
Programming LOGO!	3
LOGO! functions	4
Configuring LOGO!	5
LOGO! program module (card)	6
LOGO! Software	7
Applications	8
Technical data	A
Determining the cycle time	B
LOGO! without display	C
LOGO! menu structure	D
Order numbers	E
Abbreviations	F
Index	

Safety Guidelines

This manual contains notices you have to observe in order to ensure your personal safety, as well as to prevent damage to property. The notices referring to your personal safety are highlighted in the manual by a safety alert symbol; notices referring to property damage only have no safety alert symbol. The notices shown below are graded according to the degree of danger.



Danger

indicates that death or severe personal injury will result if proper precautions are not taken.



Warning

indicates that death or severe personal injury may result if proper precautions are not taken.



Caution

with a safety alert symbol indicates that minor personal injury can result if proper precautions are not taken.

Caution

without a safety alert symbol indicates that property damage can result if proper precautions are not taken.

Attention

indicates that an unintended result or situation can occur if the corresponding notice is not taken into account.

If more than one degree of danger is present, the warning notice representing the highest degree of danger will be used. A notice warning of injury to persons with a safety alert symbol may also include a warning relating to property damage.

Qualified Personnel

The device/system may only be set up and used in conjunction with this documentation. Commissioning and operation of a device/system may only be performed by qualified personnel. Within the context of the safety notices in this documentation qualified persons are defined as persons who are authorized to commission, ground and label devices, systems and circuits in accordance with established safety practices and standards.

Prescribed Usage

Note the following:



Warning

This device and its components may only be used for the applications described in the catalog or the technical description, and only in connection with devices or components from other manufacturers which have been approved or recommended by Siemens.

Correct, reliable operation of the product requires proper transport, storage, positioning and assembly as well as careful operation and maintenance.

Trademarks

All names identified by ® are registered trademarks of the Siemens AG. The remaining trademarks in this publication may be trademarks whose use by third parties for their own purposes could violate the rights of the owner.

Copyright Siemens AG 2004 All rights reserved

The distribution and duplication of this document or the utilization and transmission of its contents are not permitted without express written permission. Offenders will be liable for damages. All rights, including rights created by patent grant or registration of a utility model or design, are reserved

Disclaimer of Liability

We have reviewed the contents of this publication to ensure consistency with the hardware and software described. Since variance cannot be precluded entirely, we cannot guarantee complete consistency. However, the information in this publication is reviewed regularly and any necessary corrections are included in subsequent editions.

Siemens AG
Automation and Drives
Postfach 4848, D-90327 Nuernberg

Siemens AG 2004
Technical data subject to change.

Preface

Dear customer

We thank you for purchasing LOGO! and congratulate you on your decision. With LOGO! you have acquired a logic module that meets the stringent quality requirements of ISO 9001.

LOGO! can be used in many fields of applications. Due to its high functionality and yet easy operation, LOGO! offers you utmost efficiency for almost any application.

Purpose of this manual

This LOGO! manual provides you with information about the creation of circuit programs, about the installation and use of LOGO! 0BA5 devices and expansion modules, and about their compatibility with the previous 0BA0-0BA4 versions (0BAx are the last four characters of the order number and differentiate the device series).

LOGO!'s place in information technology

The wiring information in your LOGO! manual is also found in the LOGO! Product Info included with all devices. For further information on programming the LOGO! on your PC, refer to the Online Help for LOGO!Soft Comfort.

LOGO!Soft Comfort is the programming software for PCs. It runs under Windows[®], Linux[®], Mac OS X[®] and helps you to get started with LOGO! and to write, test, print out and archive your programs, independent of the LOGO! .

Guide

We have divided this manual into 9 chapters:

- Getting started with LOGO!
- LOGO! installation and wiring
- Programming LOGO!
- LOGO! functions
- Configuring LOGO!
- LOGO! program module (card)
- LOGO! software
- Applications
- Appendix

Valid range of this manual

The manual applies to devices of series 0BA5.

Changes compared to previous releases of the manual

- The digital modules LOGO! DM16 24, DM16 24R and DM16 230R were added.
- The analog module LOGO! AM 2 AQ was added.
- The communication modules CM EIB/KNX and CM AS interface were added.
- Description of changes and new features of the series 0BA5 devices.

Main differences compared to previous devices (0BA0 to 0BA4)

- Display contrast may be changed.
- Default setting for the start screen may be changed.
- Analog output values for RUN/STOP transition may be selected.
- Analog inputs and analog outputs have been added to the RUN mode display.

New features of the current devices (0BA5)

- The “Analog ramp” special function enables you to use a two-step speed control.
- The “Analog multiplexer” special function enables you to select 1 of 4 analog values to be output.
- The “PI controller” special function enables you to use a PI controller function.

Additional support

At our Internet address

<http://www.siemens.com/logo>

you can quickly and easily find answers to your queries about LOGO!.

You can reach Technical Support as follows:

Phone: +49 (0)180 5050-222

Fax: +49 (0)180 5050-223

E-Mail: adsupport@siemens.com

Contents

Preface	i
1 Getting started with LOGO!	1
2 LOGO! installation and wiring	15
2.1 Modular LOGO! setup	19
2.1.1 Maximum setup	19
2.1.2 Setup with different voltage classes	20
2.1.3 Compatibility	22
2.2 Installing/removing LOGO!	23
2.2.1 DIN rail mounting	24
2.2.2 Wall-mounting	28
2.2.3 Labeling LOGO!	29
2.3 Wiring LOGO!	30
2.3.1 Connecting the power supply	30
2.3.2 Connecting LOGO! inputs	32
2.3.3 Connecting outputs	40
2.3.4 Connecting the EIB bus	42
2.3.5 Connecting the AS interface bus	43
2.4 Putting into operation	46
2.4.1 Switching on the LOGO!/Power On	46
2.4.2 Putting into operation of CM EIB/KNX	49
2.4.3 Operating states	49
3 Programming LOGO!	53
3.1 Connectors	55
3.2 EIB inputs/outputs	58
3.3 Blocks and block numbers	60
3.4 The way to LOGO!, starting with the circuit diagram	63
3.5 The four golden rules for operating LOGO!	66
3.6 Overview of LOGO! menus	68

3.7	Writing and starting the circuit program	69
3.7.1	Selecting programming mode	69
3.7.2	The first circuit program	71
3.7.3	Circuit program input	72
3.7.4	Assigning a circuit program name	78
3.7.5	Password	79
3.7.6	Switching LOGO! to RUN mode	84
3.7.7	Second circuit program	87
3.7.8	Deleting a block	93
3.7.9	Deleting block groups	94
3.7.10	Correcting programming errors	95
3.7.11	Selecting analog output values for RUN/STOP transition	96
3.7.12	Deleting the circuit program	97
3.7.13	Summertime/wintertime conversion	98
3.7.14	Synchronization	103
3.8	Memory space and circuit dimensions	106
4	LOGO! functions	111
4.1	Constants and connectors – Co	112
4.2	Basic functions list – GF	115
4.2.1	AND	117
4.2.2	AND with edge evaluation	118
4.2.3	NAND (not AND)	119
4.2.4	NAND with edge evaluation	120
4.2.5	OR	121
4.2.6	NOR (not OR)	122
4.2.7	XOR (exclusive OR)	123
4.2.8	NOT (Negation, Inverter)	123
4.3	Basics on special functions	124
4.3.1	Designation of the inputs	125
4.3.2	Time response	126
4.3.3	Backup of the real-time clock	127
4.3.4	Retentivity	128
4.3.5	Parameter protection	128
4.3.6	Calculating the gain and offset of analog values	129
4.4	Special functions list – SF	132
4.4.1	On-delay	136
4.4.2	Off-delay	140

4.4.3	On-/Off-delay	142
4.4.4	Retentive on-delay	144
4.4.5	Wiping relay (pulse output)	146
4.4.6	Edge triggered wiping relay	148
4.4.7	Asynchronous pulse generator	151
4.4.8	Random generator	153
4.4.9	Stairway lighting switch	155
4.4.10	Multiple function switch	158
4.4.11	Weekly timer	161
4.4.12	Yearly timer	166
4.4.13	Up/down counter	169
4.4.14	Hours counter	173
4.4.15	Threshold trigger	178
4.4.16	Analog threshold trigger	181
4.4.17	Analog differential trigger	184
4.4.18	Analog comparator	188
4.4.19	Analog value monitoring	193
4.4.20	Analog amplifier	196
4.4.21	Latching relay	198
4.4.22	Pulse relay	199
4.4.23	Message texts	202
4.4.24	Softkey	209
4.4.25	Shift register	213
4.4.26	Analog Multiplexer	216
4.4.27	Analog Ramp	220
4.4.28	PI controller	225
5	Configuring LOGO!	233
5.1	Selecting parameter assignment mode	234
5.1.1	Parameters	236
5.1.2	Selecting the parameters	237
5.1.3	Modifying parameters	238
5.2	Setting the default values for LOGO!	241
5.2.1	Setting the time-of-day and date (LOGO! ... C)	241
5.2.2	Setting the display contrast	243
5.2.3	Setting the start screen	244

6	LOGO! program module (card)	245
6.1	Security function (CopyProtect)	247
6.2	Inserting and removing the program module (card)	250
6.3	Copying data from LOGO! to the program module (card)	252
6.4	Copying data from the program module (card) to LOGO!	254
7	LOGO! Software	257
7.1	Connecting LOGO! to a PC	260
8	Applications	263

Appendix

A	Technical data	267
A.1	General technical data	267
A.2	Technical data: LOGO! 230...	270
A.3	Technical data: LOGO! DM8 230R and LOGO! DM16 230R	273
A.4	Technical data: LOGO! 24...	276
A.5	Technical data: LOGO! DM8 24 and LOGO! DM16 24	279
A.6	Technical data: LOGO! 24RC...	282
A.7	Technical data: LOGO! DM8 24 R and LOGO! DM16 24 R	285
A.8	Technical data: LOGO! 12/24... and LOGO! DM8 12/24R	288
A.9	Switching capacity and service life of the relay outputs	291
A.10	Technical data: LOGO! AM 2	292
A.11	Technical data: LOGO! AM 2 PT100	293
A.12	Technical data: LOGO! AM 2 AQ	295
A.13	Technical data: CM EIB/KNX	296
A.14	Technical data: LOGO!Power 12 V	298
A.15	Technical data: LOGO!Power 24 V	300
A.16	Technical data: LOGO! Contact 24/230	302
A.17	Technical data: LOGO! Contact 24/230	304
B	Determining the cycle time	303
C	LOGO! without display	305
D	LOGO! menu structure	309
E	Order numbers	311
F	Abbreviations	313
	Index	315

1 Getting started with LOGO!

Here's LOGO!

LOGO! is a universal logic module made by Siemens.

LOGO! integrates

- Controls
- Operator and display panel with background lighting
- Power supply
- Interface for expansion modules
- Interface for the program module (card) and a PC cable
- Pre-configured standard functions, e.g. on- and off-delays, pulse relay and softkey
- Timer
- Digital and analog flags
- Inputs and outputs, according to the device type.

What LOGO! can do for you

LOGO! offers solutions for domestic and installation engineering (e.g. for stairway lighting, external lighting, sun blinds, shutters, shop window lighting etc.), switch cabinet engineering, as well as for mechanical and apparatus engineering (e.g. for gate control systems, air-conditioning systems, or rainwater pumps etc.).

LOGO! can also be implemented for special control systems in conservatories or greenhouses, for control signal processing and, by connecting a communication module (e.g. ASi), for distributed local controlling of machines and processes.

Special versions without operator panel and display unit are available for series production applications in small machine, apparatus, switching cabinet and installation engineering.

Which devices are available?

LOGO! Basic is available in two voltage classes:

- Class 1 ≤ 24 V, i.e. 12 V DC, 24 V DC, 24 V AC
- Class 2 > 24 V, i.e. 115...240 V AC/DC,

in the versions:

- **With display:** 8 inputs and 4 outputs.
- **Without display** ("LOGO! Pure"): 8 inputs and 4 outputs.

Each version is integrated into 4 subunits (SU), is equipped with an expansion interface and provides 36 pre-configured standard and special function blocks for the creation of your circuit program.

Which expansion modules are available?

- LOGO! digital modules DM8... are available for operation with 12 V DC, 24 V AC/DC and 115...240 V AC/DC, and are equipped with four inputs and four outputs.
- LOGO! digital modules DM16... are available for operation with 24 V DC and 115...240 V AC/DC, and are equipped with eight inputs and eight outputs.
- LOGO! analog modules are available for operation with 24 V DC and (some) with 12 V DC, and are equipped with two analog inputs or two Pt100 inputs or two analog outputs.

The digital/analog modules are integrated in two or four subunits. Each one is equipped with two expansion interfaces for connecting additional modules.

Which communication modules are available?

- LOGO! communication module (CM) AS interface, which is described in more detail in a separate documentation.

The communication module has four virtual inputs and outputs, and acts as an interface between an AS-Interface system and a LOGO! system. The module enables four data bits to be transferred from the LOGO! Basic to the AS-Interface system and vice versa.

- LOGO! communication module (CM) EIB/KNX, which is described in more detail in a separate documentation.

CM EIB/KNX is a communication module (CM) for connecting the LOGO! to the *EIB*.

As an interface to *EIB*, CM EIB/KNX makes it possible to communicate with other *EIB* devices. To do this, you store a configuration in the CM EIB/KNX that specifies the inputs/outputs of the LOGO! to the *EIB* bus that are to be mapped. You can interconnect the corresponding inputs/outputs using LOGO! functions.

It's your choice

The various LOGO! Basic versions, expansion modules and communication modules offer you a highly flexible and adaptive system to suit your specific tasks.

The LOGO! system offers you many solutions such as for small domestic installations, simple automation tasks, and even complex engineering tasks involving its integration into a bus system (e.g. communication module AS interface).

Note

LOGO! Basic may only be equipped with expansion modules of the same voltage class. Mechanical encoding pins in the housing prevent you from connecting devices of a different voltage class.

Exception: The left-hand interface of an analog module or communication module is galvanically isolated.

This type of expansion module can therefore be connected to devices of a different voltage class.

See also Chapter 2.1.

Each LOGO! Basic provides the following connections for the creation of the circuit program, regardless of the number of connected modules:

- Digital inputs I1 to I24
- Analog inputs AI1 to AI8
- Digital outputs Q1 to Q16
- Analog outputs AQ1 and AQ2
- Digital flag blocks M1 to M24, M8: Startup flag
- Analog flag blocks AM1 to AM6
- Shift register bits S1 to S8
- 4 cursor keys
- 16 blank outputs X1 to X16.

The LOGO! structure

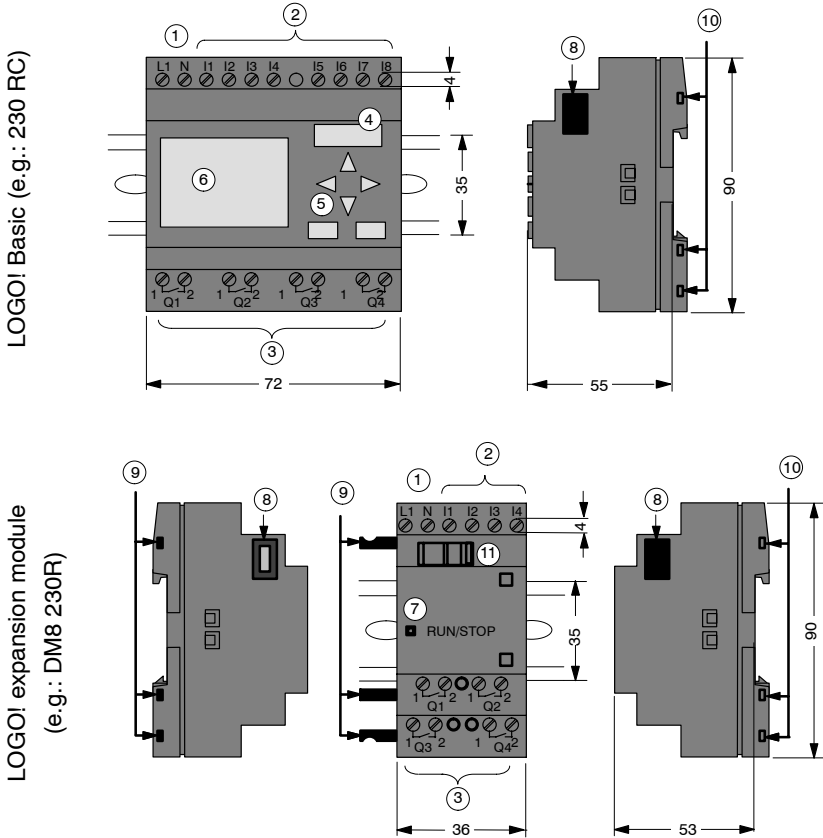

- | | | |
|------------------------|-------------------------------|-----------------------------|
| ① Power supply | ⑤ Control panel (not for RCo) | ⑧ Expansion interface |
| ② Inputs | ⑥ LCD (not for RCo) | ⑨ Mechanical coding pins |
| ③ Outputs | ⑦ RUN/STOP indicator | ⑩ Mechanical coding sockets |
| ④ Module slot with cap | ⑪ Slide | |

LOGO! Basic (e.g.: 12/24 RC)

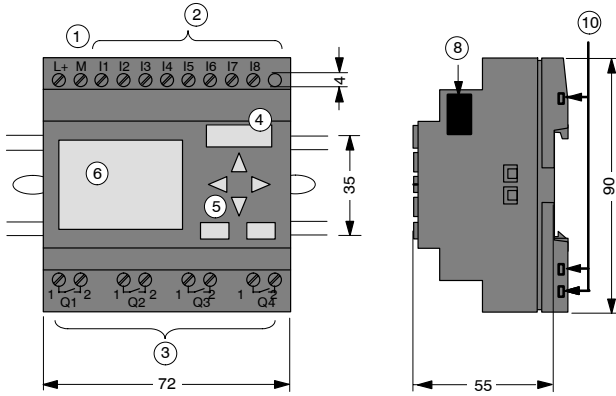

LOGO! expansion module
(e.g.: DM8 12/24R)

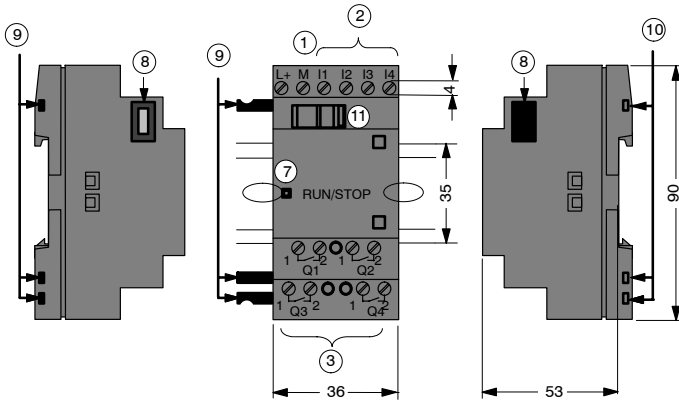

- | | | |
|------------------------|----------------------------------|--------------------------------|
| ① Power supply | ⑤ Control panel
(not for RCo) | ⑧ Expansion interface |
| ② Inputs | ⑥ LCD | ⑨ Mechanical coding
pins |
| ③ Outputs | ⑦ RUN/STOP indicator | ⑩ Mechanical coding
sockets |
| ④ Module slot with cap | | ⑪ Slide |

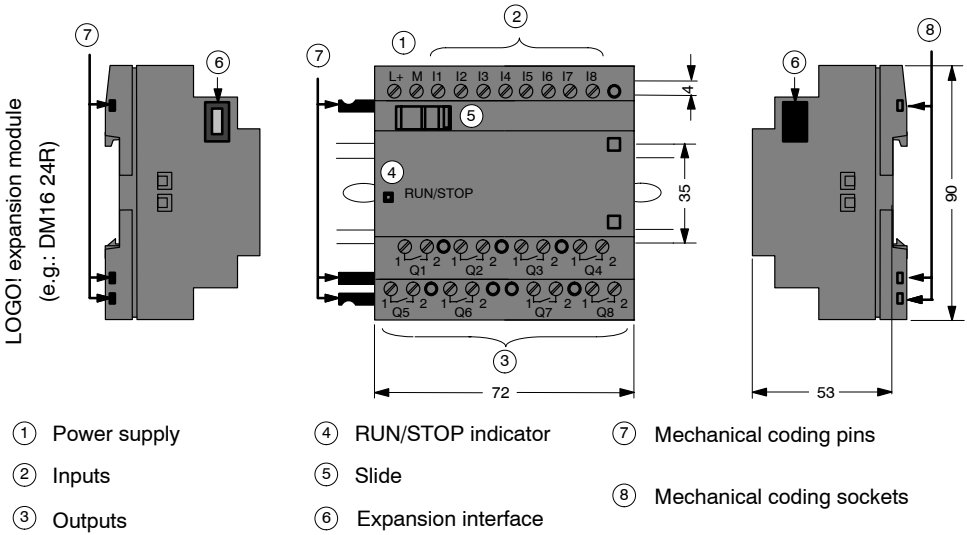

LOGO! AM 2

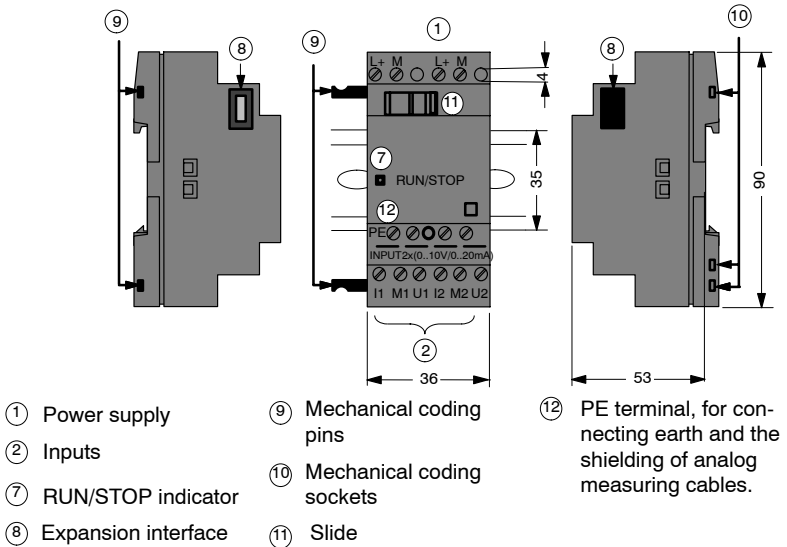

LOGO! AM 2 AQ

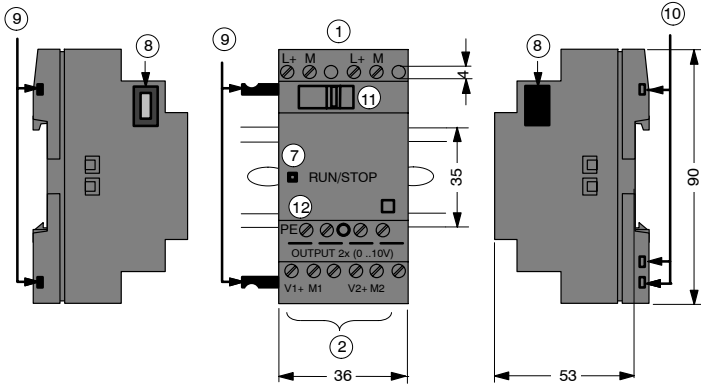

- ① Power supply
- ② Inputs
- ⑦ RUN/STOP indicator
- ⑧ Expansion interface
- ⑨ Mechanical coding pins
- ⑩ Mechanical coding sockets
- ⑪ Slide
- ⑫ PE terminal, for connecting earth

LOGO! CM EIB/KNX

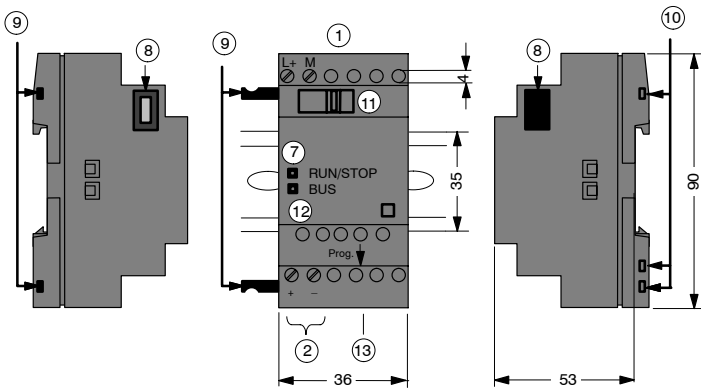

- ① Power supply
- ② EIB bus connection
- ⑦ RUN/STOP indicator, communication with the LOGO!
- ⑧ Expansion interface
- ⑨ Mechanical coding pins
- ⑩ Mechanical coding sockets
- ⑪ Slide
- ⑫ LED for status display of EIB/KNX
- ⑬ Programming button

How to identify LOGO!

The LOGO! identifier informs you of various properties:

- 12/24: 12/24 V DC version
- 230: 115...240 V AC version
- R: Relay outputs (without R: solid-state outputs)
- C: Integrated weekly timer
- o: Version without display ("LOGO! Pure")
- DM: Digital module
- AM: Analog module
- CM: Communication module (e.g. EIB/KNX module)

Symbols



Version with display unit is equipped with 8 inputs and 4 outputs



Version without display unit is equipped with 8 inputs and 4 outputs



The digital module is equipped with 4 digital inputs and 4 digital outputs



The digital module is equipped with 8 digital inputs and 8 digital outputs





The analog module is equipped with 2 analog inputs or two analog outputs, according to the device type



The communication module (CM); e.g. AS Interface is equipped with 4 virtual inputs and 4 virtual outputs

Versions

The following LOGO! versions are available:

Symbol	Designation	Supply voltage	Inputs	Outputs	Properties
	LOGO! 12/24 RC	12/24 V DC	8 digital (1)	4 relays (10 A)	
	LOGO! 24	24 V DC	8 digital (1)	4 solid state 24V / 0.3A	no clock
	LOGO! 24RC (3)	24 V AC/ 24 V DC	8 digital	4 relays (10A)	
	LOGO! 230RC (2)	115...240 V AC/DC	8 digital	4 relays (10A)	
	LOGO! 12/24RCo	12/24 V DC	8 digital (1)	4 relays (10A)	no display unit no keyboard
	LOGO! 24o	24 V DC	8 digital (1)	4 solid state 24 V / 0.3A	no display unit no keyboard no clock
	LOGO! 24RCo (3)	24 V AC / 24 V DC	8 digital	4 relays (10A)	no display unit no keyboard
	LOGO! 230RCo (2)	115...240 V AC/DC	8 digital	4 relays (10A)	no display unit no keyboard



(1): Of those can be used alternatively: 2 analog inputs (0 ... 10V) and 2 fast inputs.

(2): 230 V AC versions: Two groups consisting of 4 inputs each. Each input within a group must be connected to the same phase. It is possible to interconnect groups with a different phase.

(3): The digital inputs can be operated with P or N action.

Expansion modules

The following expansion modules can be connected to LOGO!:

Symbol	Name	Power supply	Inputs	Outputs
	LOGO! DM 8 12/24R	12/24 V DC	4 digital	4 relays (5A)
	LOGO! DM 8 24	24 V DC	4 digital	4 solid state 24V / 0.3A
	LOGO! DM 8 24R ⁽³⁾	24 V AC/DC	4 digital	4 relays (5A)
	LOGO! DM 8 230R	115...240 V AC/DC	4 digital ⁽¹⁾	4 relays (5A)
	LOGO! DM 16 24	24 V DC	8 digital	8 solid state 24V / 0.3A
	LOGO! DM 16 24R	24 V DC	8 digital	8 relays (5A)
	LOGO! DM 16 230R	115...240 V AC/DC	8 digital ⁽⁴⁾	8 relays (5A)
	LOGO! AM 2	12/24 V DC	2 analog 0 ... 10V or 0 ... 20mA ⁽²⁾	none
	LOGO! AM 2 PT100	12/24 V DC	2 Pt100 -50 °C to +200 °C	none
	LOGO! AM 2 AQ	24 V DC	none	2 analog 0 ... 10 V DC

(1): Different phases are not allowed within the inputs.

(2): 0 ... 10 V, 0 ... 20 mA can be connected optionally.

(3): Digital inputs can be operated either with P or with N action.

(4): Two groups consisting of 4 inputs each. Each input within a group must be connected to the same phase. It is possible to interconnect groups with a different phase.

Communication modules

The following communication modules can be connected to LOGO!:

Symbol	Name	Power supply	Inputs	Outputs
	LOGO! CM AS Interface	24 V DC	the next four inputs after the physical inputs of LOGO! ($I_n \dots I_{n+3}$)	the next four outputs after the physical outputs of LOGO! ($Q_n \dots Q_{n+3}$)
	LOGO! CM EIB/KNX	24 V AC/DC	max. 16 virtual digital inputs (I); max. 8 virtual analog inputs (AI)	max. 12 virtual digital outputs (Q); max. 2 virtual analog outputs (AA)

Certification and approvals

LOGO! is certified to cULus and FM.

- cULus Haz. Loc.
Underwriters Laboratories Inc. (UL) to
 - UL 508 (Industrial Control Equipment)
 - CSA C22.2 No. 142 (Process Control Equipment)
 - UL 1604 (Hazardous Location)
 - CSA-213 (Hazardous Location)
 APPROVED for use in
 Class I, Division 2, Group A, B, C, D Tx
 Class I, Zone 2, Group IIC Tx
- FM Approval
Factory Mutual Research (FM) to
Approval Standard Class Number 3611, 3600, 3810
 APPROVED for use in
 Class I, Division 2, Group A, B, C, D Tx
 Class I, Zone 2, Group IIC Tx

Note

You will find current approvals on the rating plate of the relevant module.



Warning

Risk of personal injury and material damage.

In potentially explosive atmospheres, there is a risk of personal injury or damage to material if you disconnect connectors when the system is in RUN.

In potentially explosive atmospheres, always switch off the power supply to LOGO! and its components before you disconnect any connectors.

LOGO! is issued with the CE Certificate of Conformity. It is compliant with VDE 0631 and IEC 61131-2 and interference-proof to EN 55011, Limit Class B.

Marine certification has been requested.

- ABS (American Bureau of Shipping)
- BV (Bureau Veritas)
- DNV (Det Norske Veritas)
- GL (Germanischer Lloyd)
- LRS (Lloyds Register of Shipping)
- Class NK (Nippon Kaiji Kyokai)

LOGO! is therefore suitable for use both in industry and in the domestic area.

ID for Australia



Our products carrying the label shown at the side are compliant with AS/NZS 2064:1997 (Class A) standard.

Recycling and Disposal

LOGO! units can be fully recycled, due to their low-pollutant equipment. Contact a certified electronic waste disposal center for environmentally acceptable recycling and disposal of your old devices.

2 LOGO! installation and wiring

General guidelines

Please note the following guidelines for installing and wiring your LOGO!:

- Always ensure that the wiring of your LOGO! is compliant with current rules and standards. Also, conform with all national and regional regulations when you install and operate the devices. For information on standards and regulations that apply to your specific case, contact your local authorities.
- Always switch off power before you wire or install/remove a module.
- Always use cables with appropriate conductor cross-sections for the relevant current. You can wire LOGO! with cable conductor cross-sections from 1.5 mm² to 2.5 mm²; see Chapter 2.3.
- Do not exceed the screw torque of the terminals. The maximum torque is: 0.5 N/m, see Chapter 2.3.
- Keep the cabling as short as possible. If longer cables are necessary, you should use shielded versions. You should always route your cables in pairs: i.e. one neutral conductor plus one phase conductor or signal line.
- Always keep separate:
 - The AC wiring
 - High-voltage DC circuits with high-frequency switching cycles
 - Low-voltage signal wiring.
 - The EIB bus cable may also be laid in parallel to other signal lines.
- Ensure that the wires are installed with appropriate strain relief.
- Provide a suitable lightning surge arrester for cables installed in hazardous areas.

- Do not connect an external power supply in parallel to the output load of a DC output. This could develop a reverse current at the output if you have not installed a diode or similar barrier device.
- Reliable functioning of the equipment is only ensured with certified components!

Note

LOGO! units may only be installed and wired by skilled personnel who are familiar with and follow general engineering rules and relevant regulations and standards.

What you must note when installing

LOGO! is designed for fixed and enclosed installation in the housing or the control cabinet.



Warning

Open facilities

Death, serious bodily injury or considerable damage to property can occur.

Modules of a LOGO! are open facilities. This means you must install LOGO! only in a housing or cabinet.

Access to the housings or cabinets must only be possible by using a key or a tool and only authorized or approved personnel may be allowed access.

It is permissible to operate LOGO! from its front at any time.

Safety of electronic control equipment

Introduction

The notes below apply regardless of the type or manufacturer of the electronic control.

Reliability

Maximum reliability of LOGO! devices and components is achieved by implementing extensive and cost-effective measures during development and manufacture.

This includes the following:

- Use of high-quality components;
- Worst-case design of all circuits;
- Systematic and computer-aided testing of all components;
- Burn-in of all large-scale integrated circuits (e.g. processors, memory, etc.);
- Measures preventing static charge when handling MOS ICs;
- Visual checks at different stages of manufacture;
- Continuous heat-run test at elevated ambient temperature over a period of several days;
- Careful computer-controlled final testing;
- Statistical evaluation of all returned systems and components to enable the immediate initiation of suitable corrective measures;
- Monitoring of major control components, using online tests (cyclic interrupt for the CPU, etc.).

These measures are referred to as basic measures.

Carrying out tests

You must, however, ensure safety in your plant.

Before finally commissioning a system you should carry out complete functional testing as well as all the necessary safety testing.

In testing, also include any predictable faults that can occur. This means that you will avoid any danger to the plant or to people during operation.

Risks

In all cases where the occurrence of failures can result in material damage or injury to persons, special measures must be taken to enhance the safety of the installation - and therefore also of the situation. System-specific and special regulations exist for such applications. They must be observed on installing the control system (e.g. VDE 0116 for burner control systems).

For electronic control equipment with a safety function, the measures that have to be taken to prevent or rectify faults are based on the risks involved in the installation. As of a certain degree of hazard the basic measures mentioned above are no longer sufficient. Additional measures must be implemented and approved for the controller.

Important information

The instructions in the operating manual must be followed exactly. Incorrect handling can render measures intended to prevent dangerous faults ineffective, or generate additional sources of danger.

2.1 Modular LOGO! setup

2.1.1 Maximum setup

Maximum setup of a LOGO! *with* analog inputs (LOGO! 12/24 RC/RCo and LOGO! 24/24o)

LOGO! Basic, 4 digital modules and 3 analog modules (example)

I1.....I6, I7, I8 AI1, AI2	I9...I12	I13...I16	I17...I20	I21...I24	AI3, AI4	AI5, AI6	AI7, AI8
LOGO! Basic	LOGO! DM 8	LOGO! DM 8	LOGO! DM 8	LOGO! DM 8	LOGO! AM 2	LOGO! AM 2	LOGO! AM 2
Q1...Q4	Q5...Q8	Q9...Q12	Q13...Q16				

In addition, you can plug in an analog output module.

Maximum setup of a LOGO! *without* analog inputs (LOGO! 24 RC/RCo and LOGO! 230 RC/RCo)

LOGO! Basic, 4 digital modules and 4 analog modules (example)

I1 I8	I9...I12	I13...I16	I17...I20	I21...I24	AI1 , AI2	AI3, AI4	AI5, AI6	AI7, AI8
LOGO! Basic	LOGO! DM 8	LOGO! DM 8	LOGO! DM 8	LOGO! DM 8	LOGO! AM 2	LOGO! AM 2	LOGO! AM 2	LOGO! AM 2
Q1...Q4	Q5...Q8	Q9...Q12	Q13... Q16					

In addition, you can plug in an analog output module.

High-speed/optimal communication performance

For optimal and high-speed communication performance between LOGO! Basic and the various modules, we recommend you install the “digital modules first, then the analog modules” (examples above). (The special function PI controller is an exception: the AI used for the value PV should be on the LOGO! Basic or an analog input module adjacent to the LOGO! Basic).

We **recommend** that you position the CM AS Interface on the far right-hand side. (If the AS Interface voltage fails, communication between the LOGO! system and the expansion modules, which are arranged to the right of the LOGO! CM AS Interface expansion module, is interrupted).

Note

CM EIB/KNX **must** always be installed as the last module on the right-hand side of LOGO! as no further interface modules may be connected to the CM EIB/KNX.

2.1.2 Setup with different voltage classes

Rules

Digital modules can only be connected to devices of the same voltage class.

You may connect analog and communication modules to devices of any voltage class.

You may replace two similar DM8 expansion modules by one appropriate DM16 expansion module (and vice versa) without having to change the circuit program.

Note

Two DM8 12/24R may be replaced by one DM16 24R only if operated with a power supply of 24 V DC.

Two DM8 24R may be replaced by one DM16 24R only if operated with DC and P action.

Overview:
Connecting an expansion module to LOGO! Basic

LOGO! Basic	Expansion modules					
	DM8 12/24R, DM16 24R	DM8 24, DM16 24	DM 8 24R	DM8 230R, DM16 230R	AM2, AM2 PT100, AM2 AQ	CM
LOGO! 12/24 RC	x	x	x	—	x	x
LOGO! 24	x	x	x	—	x	x
LOGO! 24 RC	x	x	x	—	x	x
LOGO! 230 RC	—	—	—	x	x	x
LOGO! 12/24RCo	x	x	x	—	x	x
LOGO! 24o	x	x	x	—	x	x
LOGO! 24 RCo	x	x	x	—	x	x
LOGO! 230 RCo	—	—	—	x	x	x

Overview:
Connecting a further expansion module to an expansion module

Expansion module	Further expansion modules					
	DM8 12/24R, DM16 24R	DM8 24, DM16 24	DM 8 24R	DM8 230R, DM16 230R	AM2, AM2 PT100, AM2 AQ	CM
DM 8 12/24R, DM 16 24R	x	x	x	—	x	x
DM 8 24, DM 16 24	x	x	x	—	x	x

Expansion module	Further expansion modules					
	DM8 12/24R, DM16 24R	DM8 24, DM16 24	DM 8 24R	DM8 230R, DM16 230R	AM2, AM2 PT100, AM2 AQ	CM
DM 8 24 R	x	x	x	—	x	x
DM 8 230R, DM 16 230R	—	—	—	x	x	x
AM 2, AM 2 PT100, AM 2 AQ	x	x	x	—	x	x
CM AS Interface	x	x	x	—	x	x

2.1.3 Compatibility

All currently available expansion modules are completely compatible with the basic modules of equipment series 0BA3 and 0BA4.

When using the LOGO! AM 2 AQ analog module with equipment series 0BA4, the functions are limited to the ones available on this equipment. You cannot use the module with equipment series 0BA3.

2.2 Installing/removing LOGO!

Dimensions

The LOGO! installation dimensions are compliant with DIN 43880.

LOGO! can be snap-mounted to 35 mm DIN rails to EN 50022 or on the wall.

LOGO! width:

- LOGO! Basic has a width of 72 mm, which corresponds with 4 subunits.
- LOGO! expansion modules have a width of 36 mm or 72 mm (DM16...), which corresponds with 2 or 4 subunits.

Note

The figure below shows you an example of the installation and removal of a LOGO! 230 RC and a digital module. The measures shown apply to all other LOGO! Basic versions and expansion modules.



Warning

Always switch off power before you “remove” and “insert” an expansion module.

2.2.1 DIN rail mounting

Mounting

How to **mount** a LOGO! Basic **and** a digital module onto a DIN rail:

LOGO! Basic:

1. Hook the LOGO! Basic module onto the rail and
2. then push down the lower end to snap it on. The mounting interlock at the rear must engage

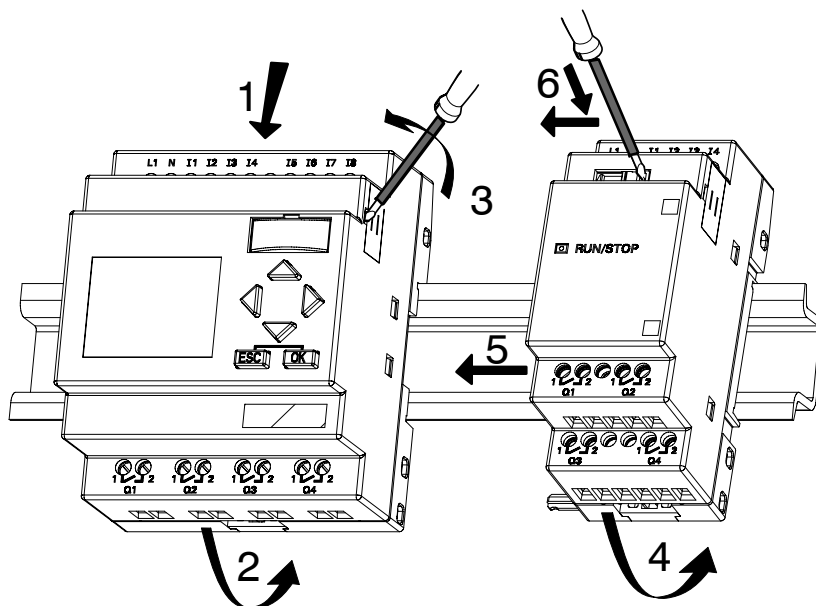

LOGO! digital module:

3. On the right side of the LOGO! Basic/LOGO! expansion module, remove the connector cap
4. Place the digital module onto the DIN rail on the right-hand side of the LOGO! Basic
5. Slide the digital module towards the left until it contacts the LOGO! Basic

- Using a screwdriver, push the interlock to the left. In its end position the slide interlock engages in LOGO! Basic.

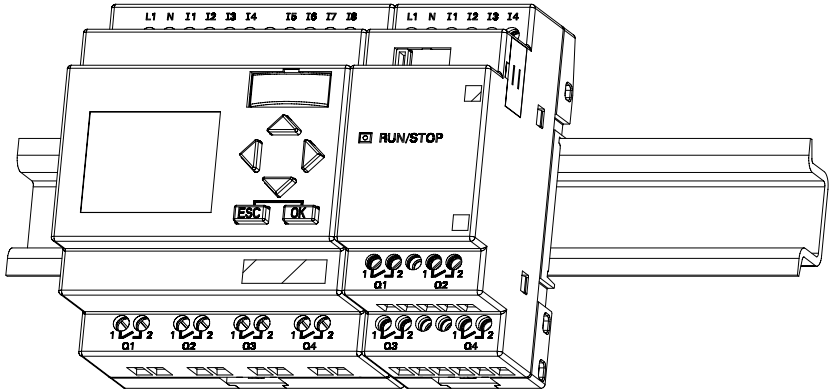

Repeat steps 3 through 6 to mount further expansion modules.

Note

The expansion interface on the last expansion module must be covered.

Removal

To **remove** LOGO!:

..... if you have installed **only one LOGO! Basic**:

Part **A**

1. Insert a screwdriver into the eyelet at the bottom of the slide interlock and move the latch downward
2. Swing the LOGO! Basic off the DIN rail.

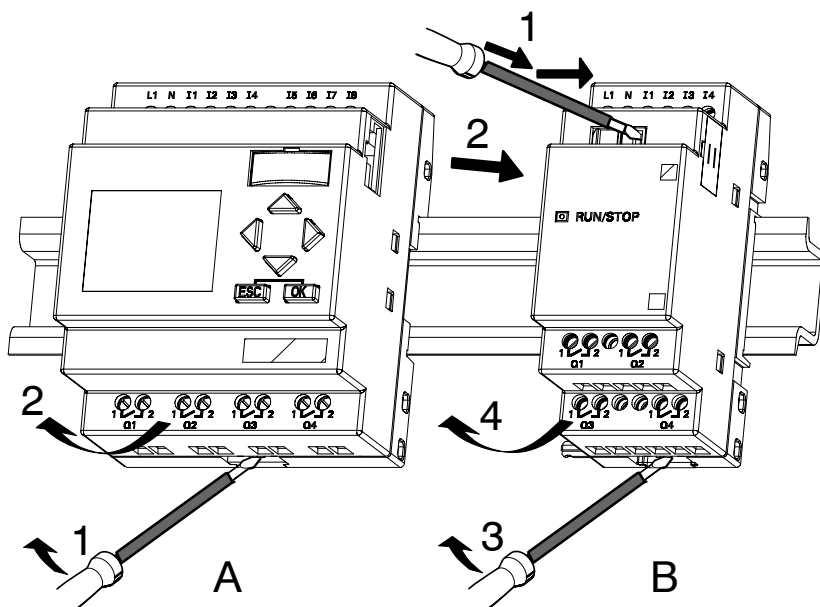

..... if you have connected **at least one expansion module** to LOGO! Basic:

Part B

1. Using a screwdriver, push the integrate slide interlock to the right
2. Slide the expansion module off towards the right
3. Insert a screwdriver into the eyelet at the bottom of the slide interlock and lever it downward
4. Swing the expansion module off the profile rail.

Repeat steps 1 to 4 for all other expansion modules.

Note

If you have connected more than one expansion module, it is advisable to start removal with the last module at the right-hand side.

Make sure the slide interlock of the module to be installed/removed is not engaged in the next module.

2.2.2 Wall-mounting

For wall-mounting, first slide the mounting slides on the rear side of the devices towards the **outside**. You can now wall-mount LOGO! by means of two mounting slides and two \emptyset M4 screws (tightening torque 0.8 to 1.2 N/m).

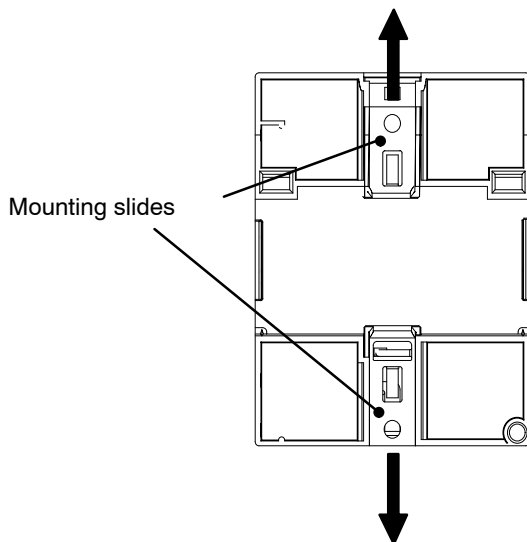

Drilling template for wall-mounting

Before you can wall-mount LOGO!, you need to drill holes using the template shown below.

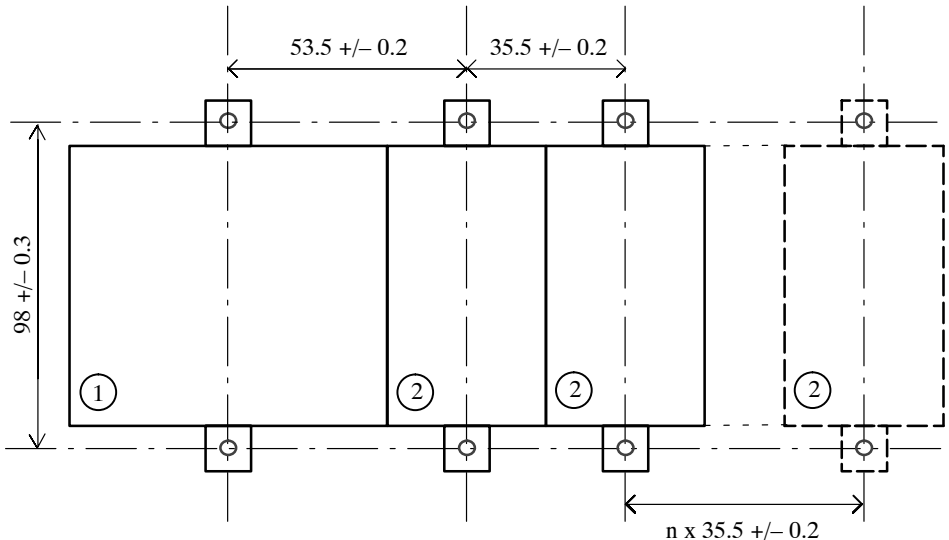

All dimensions in mm

- Bore hole for \emptyset M4 screw
- Tightening torque 0.8 to 1.2 N/m
- ① LOGO! Basic
- ② LOGO! expansion module with two subunits

2.2.3 Labeling LOGO!

The gray rectangular areas on the modules are intended for labeling the LOGO! modules.

In the case of expansion modules, you can use the gray areas for labeling the inputs and outputs, for example. In this connection, you can enter a delta factor of +8 for the inputs or +4 for the outputs if the basic module already has 8 inputs or 4 outputs.

2.3 Wiring LOGO!

Wire LOGO! using a screwdriver with a 3-mm blade.

You do not need wire ferrules for the terminals. You can use conductors with cross-sections of up to the following thicknesses:

- 1 x 2.5 mm²
- 2 x 1.5 mm² for each second terminal chamber

Tightening torque: 0.4...0.5 N/m or 3...4 lbs/in

Note

Always cover the terminals after you have completed the installation. To protect LOGO! adequately from impermissible contact to live parts, local standards must be complied with.

2.3.1 Connecting the power supply

The 230-V versions of LOGO! are suitable for operation with rated voltages of 115 V AC/DC and 240 V AC/DC. The LOGO! 24-V and 12-V versions can be operated with a 24 VDC, 24 V AC or 12 VDC power supply. For information on permissible voltage tolerances, line frequencies and power consumption, refer to the installation instructions in the Product Information supplied with your device and to the technical data in Appendix A.

The CM EIB/KNX has been designed as a communication module for the LOGO! controller and must be supplied with a mains voltage of 12/24 V AC/DC.

The AS Interface bus requires a special AS Interface power supply (30 V DC) that enables simultaneous transmission of data and power for the encoders via a single line.

Note

A power failure may cause an additional edge triggering signal at the special functions, for example.

Data of the last uninterrupted cycle are stored in LOGO!.

Connecting LOGO!

To connect LOGO! to the power supply:

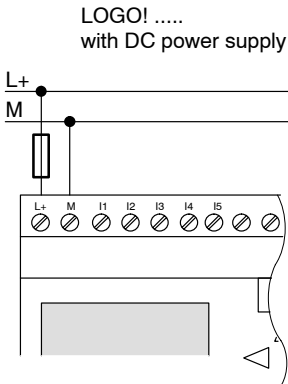

Protection with safety fuse
if required (recommended) for:

12/24 RC...:	0.8 A
24:	2.0 A
EIB/KNX	0.08 A

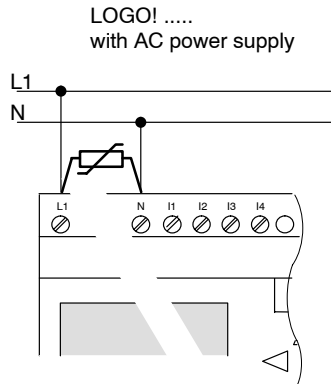

To suppress surge voltages,
install varistors (MOV) with an
operating voltage at least 20 %
above the rated voltage.

Note

LOGO! is a double-insulated switchgear. You do not need to connect an equipment grounding conductor.

Circuit protection with AC voltage

To suppress voltage peaks on the power supply lines, you can install a metal oxide varistor (MOV). Make sure the operating voltage of the varistor (MOV) used lies at least 20 % above the rated voltage (for example S10K275).

2.3.2 Connecting LOGO! inputs

Requirements

At the inputs you connect sensor elements such as: momentary switches, switches, light barriers, daylight control switches etc.

Sensor characteristics for LOGO!

	LOGO! 12/24 RC/RCo LOGO! DM8 12/24 R		LOGO! 24/24o LOGO! DM8 24	
	I1 ... I6	I7, I8	I1 ... I6	I7, I8
Signal status 0	< 5 VDC	< 5 VDC	< 5 VDC	< 5 VDC
Input current	< 1.0 mA	< 0.05 mA	< 1.0 mA	< 0.05 mA
Signal status 1	> 8 V DC	> 8 V DC	> 8 V DC	> 8 V DC
Input current	> 1.5 mA	> 0.1 mA	> 1.5 mA	> 0.1 mA

	LOGO! 24 RC/RCo (AC) LOGO! DM8 24 R (AC)	LOGO! 24 RC/RCo (DC) LOGO! DM8 24 R (DC)	LOGO! 230 RC/RCo (AC) LOGO! DM8 230 R (AC)	LOGO! 230 RC/RCo (DC) LOGO! DM8 230 R (DC)
Signal status 0	< 5 V AC	< 5 V DC	< 40 V AC	< 30 V DC
Input current	< 1.0 mA	< 1.0 mA	< 0.03 mA	< 0.03 mA
Signal status 1	> 12 V AC	> 12 V DC	> 79 V AC	> 79 V DC
Input current	> 2.5 mA	> 2.5 mA	> 0.08 mA	> 0.08 mA

	LOGO! DM16 24 R	LOGO! DM16 24	LOGO! DM16 230 R (AC)	LOGO! DM16 230 R (DC)
Signal status 0	< 5 V DC	< 5 V DC	< 40 V AC	< 30 V DC
Input current	< 1.0 mA	< 1.0 mA	< 0.05 mA	< 0.05 mA
Signal status 1	> 12 V DC	> 12 V DC	> 79 V AC	> 79 V DC
Input current	> 2.0 mA	> 2.0 mA	> 0.08 mA	> 0.08 mA

Note

The digital inputs of LOGO! 230 RC/RCo and of expansion module DM16 230R are divided into two groups, each consisting of four inputs. **Within** the same group, all inputs must be operated on the **same** phase. **Different** phases are only possible **between** the groups.

Example: I1 to I4 on phase **L1**, I5 to I8 on phase **L2**.

Inputs within the LOGO! DM8 230R may **not** be connected to different phases.

Sensor connections

Connecting glow lamps and 2-wire proximity switches (Bero) to LOGO! 230 RC/230 RCo or LOGO! DM8 230 R (AC) and LOGO! DM16 230R (AC)

The figure below shows how you connect a switch with a glow lamp to LOGO!. The current that flows through the glow lamp allows LOGO! to detect a "1" signal even though the switch contact is not closed. If, however, you use a switch the glow lamp of which is fitted with a power supply, this response does not occur.

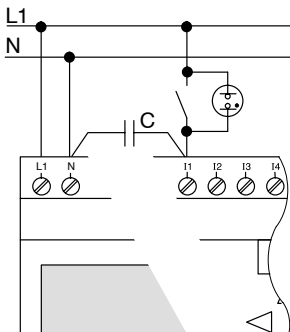

Order number for C:

Siemens
Switchgear & Systems

—||— 3SB1420-3D

X-capacitor 2.5 kV, 100 nF

Take into account the quiescent current of any 2-wire proximity switches used. The level of the quiescent current of some 2-wire proximity switches is high enough to trigger a logical "1" signal at the LOGO! input. You should therefore compare the quiescent current of the proximity switches with the technical data of inputs in Appendix A.

Remedy

To suppress this response, use Siemens components with the following order number: Capacitor 3SB 1420–3D. As an alternative, you can also use an X capacitor rated at 100 nF and 2.5 kV. In a destructive situation, this type of capacitor safely disconnects. You must choose the voltage level for which the capacitor is rated such that it is not destroyed in the case of overvoltage!

At 230 V AC, the voltage between N and an input I(n) must not be greater than 40 V to guarantee a "0" signal. You can connect approximately ten glow lamps to the capacitor.

Restrictions

- Signal status transitions 0 1 / 1 0

After a 0 to 1 or 1 to 0 transition, the signal must remain constant at the input at least for the duration of one program cycle, so that LOGO! can detect the new signal status.

The program execution time is determined by the size of the circuit program. Appendix B contains a benchmark test routine that you can use to determine the current scan cycle time.

Special features of LOGO! 12/24 RC/RCo and LOGO! 24/24o

- *High-speed inputs: I5 and I6*

These versions are also equipped with high-speed counting inputs (up/down counters, threshold triggers). The restrictions mentioned earlier do not apply to these high-speed inputs.

Note

The high-speed inputs I5 and I6 are the same as in the previous versions 0BA0 to 0BA4, i.e. a circuit program that is written in these versions can be transferred to the new 0BA5 units by means of the programming software LOGO! SoftComfort, without any changes to these features. In contrast to this, you need to modify circuit programs written for a LOGO!...L version (high-speed inputs I11/I12).

Expansion modules do not have high-speed inputs.

- *Analog inputs: I7 and I8*

The inputs I7 and I8 of LOGO! versions 12/24RC/RCo and 24/24o can be used both as standard digital inputs and as analog inputs. The input mode is defined in the LOGO! circuit program.

The inputs I7 / I8 provide digital functions, and the inputs AI1 and AI2 provide analog functions.

See also Chapter 4.1.

When using inputs I7 and I8 as analog ones, only the range from 0 to 10 V DC is available.

Connecting a potentiometer to inputs I7 / I8

To allow you to achieve 10 V as the maximum value when you completely turn the potentiometer once, you must connect a series resistor on the potentiometer's input side regardless of the input voltage (see figure below).

We suggest the following sizes of potentiometers and associated series resistors:

Voltage	Potentiometer	Series Resistor
12 V	5 k Ω	—
24 V	5 k Ω	6.6 k Ω

When using a potentiometer and 10 V input voltage as the maximum value, you must ensure that with a connected input voltage of 24 V, 14 V must release via the series resistor so that a maximum of 10 V are supplied when you turn the potentiometer one full rotation. With a voltage of 12 V, this can be neglected.

Note

The LOGO! AM 2 expansion module provides additional analog inputs. The LOGO! AM 2 PT100 expansion module provides Pt100 inputs.

Always use twisted and shielded cables for analog signals, and keep these as short as possible.

Sensor connections

To connect sensors to LOGO! :

LOGO! 12/24

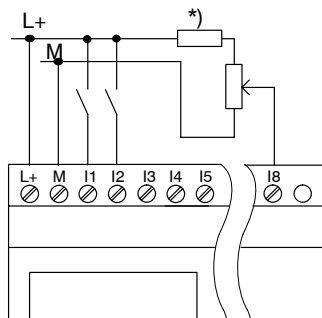

The inputs of these devices are not isolated and therefore require a common reference potential (chassis ground).

With LOGO! 12/24RC/RCo and LOGO! 24/24o modules, you can tap analog signals between the supply voltage and chassis ground (* = series resistor with 24 V DC).

LOGO! 230

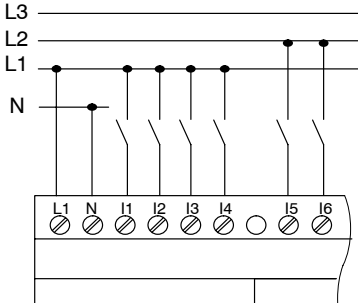

The inputs of these devices are arranged in 2 groups, each consisting of 4 inputs. Different phases are only possible between blocks, but not within the blocks.



Warning

Current safety regulations (VDE 0110, ... and IEC 61131-2, ... as well as cULus) do not permit the connection of different phases to an AC input group (I1 to I4 or I5 to I8) or to the inputs of a digital module.

LOGO! AM 2

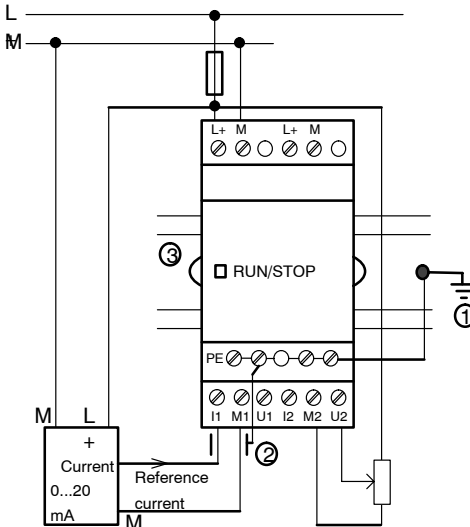

PE PE terminal for connecting earth and shielding the analog measuring cable

- ① Earth
- ② Cable shielding
- ③ DIN rail

Current measurement

Voltage measurement

The illustration above shows an example of four-wire current measurement and two-wire voltage measurement.

Connecting a two-wire sensor to the LOGO! AM 2

Wire up the two-wire sensor's connecting wires as follows:

1. Connect the sensor's output to connection U (0 ... 10 V voltage measurement) or to connection I (0 ... 20 mA current measurement) of the AM 2 module.
2. Connect the plus connector on the sensor to the 24 V supply voltage (L+).
3. Connect the ground connection on the sensor to the corresponding M input (M1 or M2) on the AM 2 module.

LOGO! AM 2 PT100

You can connect either a 2- or 3-wire Pt100 resistive thermocouple to the module.

For a **2-wire** connection, you need to short-circuit terminals M1+ and IC1 or M2+ and IC2. Errors caused by the ohmic resistance of the measuring line are not compensated for this type of connection. A line resistance of 1 Ω is proportional to a measuring error of +2.5 $^{\circ}\text{C}$.

A **3-wire** technique suppresses the influence of the cable length (ohmic resistance) on the result of the measurement.

2-wire technique

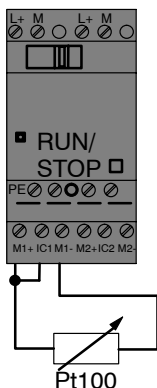

3-wire technique

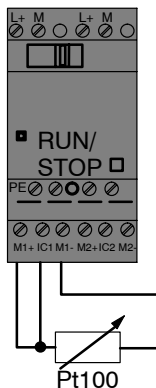

Note

Fluctuating analog values are due to screening on the connecting wire from the analog valuator device to the analog AM 2 / AM 2 PT100 LOGO! expansion module (encoder wire) that has either been mounted incorrectly or not at all. To avoid fluctuating analog values when using these expansion modules, proceed as follows:

- Use only shielded encoder wires.
 - Shorten the encoder wire as much as possible. The encoder wire must not be more than 10 meters long.
 - Clamp the encoder wire on one side only and clamp it only to the PE terminal on the AM 2 / AM 2 PT100 / AM 2 AQ expansion module.
 - Connect ground on the encoder supply to the PE terminal on the expansion module.
 - Avoid operating the LOGO! AM 2 PT100 expansion module with a power supply that is not grounded (potential-free). If you cannot avoid this, connect the negative output/ground output on the power supply to the shielding on the resistance thermometer's measuring wires.
-

2.3.3 Connecting outputs

LOGO! ...R...

The LOGO! ...R... version is equipped with relay outputs. The potential of the relay contacts is isolated from the power supply and the inputs.

Requirements for relay outputs

You can connect various loads to the outputs, e.g. lamps, fluorescent lamps, motors, contactor relays etc. For information on the properties required for the loads connected to LOGO! ...R..., refer to Appendix A.

Connecting

This is how you connect the load to LOGO! ...R...:

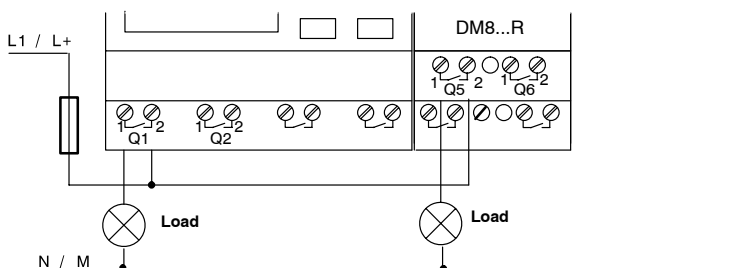

Protection with automatic circuit-breaker, max. 16 A, characteristics B16, e.g.: Power circuit-breaker 5SX2 116-6 (if required)

LOGO! with solid-state outputs

LOGO! versions with solid-state outputs can be identified by the fact that the letter **R** is missing from their type name. The outputs are short circuit-proof and overload-proof. An auxiliary load voltage supply is not necessary, because LOGO! supplies the load voltage.

Requirements for solid-state outputs

The load connected to LOGO! must have the following characteristics:

- The maximum switched current is 0.3 A per output.

Connecting

This is how you connect the load to a LOGO! with solid-state outputs:

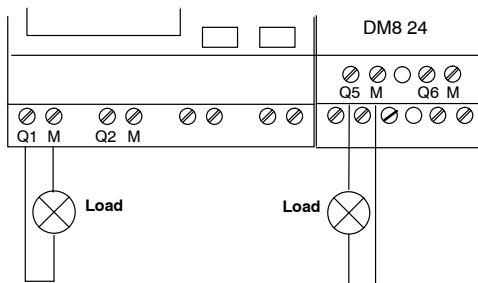

Load: 24 V DC, 0.3 A max.

LOGO! AM 2 AQ

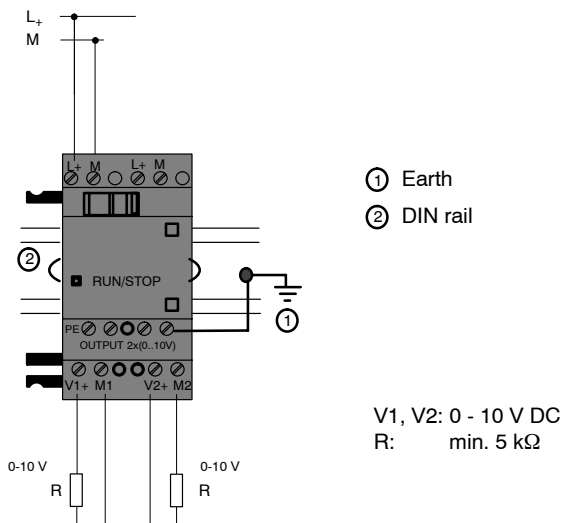

2.3.4 Connecting the EIB bus

The connection is carried out via the two-pole screw terminal (+ and -).

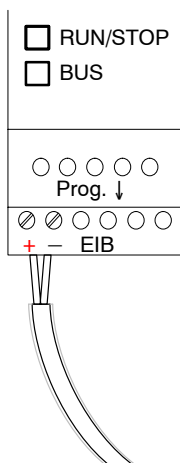

Only the red-black core pair is used, the white-yellow core pair is not connected.

Press the button “Prog ↓” to switch the CM EIB/KNX to programming mode.

Note

The button “Prog ↓” should not be pressed too firmly.
If the bus connection is OK, the LED lights up green.
In programming mode, the LED lights up orange.

Networking on the *EIB* bus

The CM EIB/KNX takes over the communication between LOGO! and *EIB* and makes communication available via *EIB* inputs/outputs.

The application of the CM EIB/KNX fills the complete LOGO! process image; i.e. inputs or outputs which are not occupied on LOGO! can be occupied via the *EIB*.

Note

For detailed information about the networking of LOGO! on the *EIB* bus please refer to the LOGO! CM EIB/KNX documentation, in particular the Micro Automation Set 8.

2.3.5 Connecting the AS interface bus

To set the address of the module on the AS interface bus, you need an addressing unit.

Valid addresses are in the range of 1 to 31. Use each address once only.

You can set the address on the AS interface bus before or after installation.

If the installed module is addressed via the address socket, the AS-Interface voltage must be disconnected beforehand.

This is necessary for safety reasons.

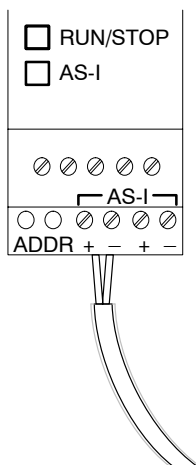

Networking on the AS interface bus

To make the connection to the AS interface bus, you need a communications-capable LOGO! variant:

- LOGO! basic module + CM AS-I.

To be able to send data across the AS interface bus to LOGO! and to receive data from it in the same way, you also need

- an AS interface power supply and
- an AS interface master (e.g. an S7-200 with a CP243-2 or a DP/AS-I Link 20 E).

LOGO! can only be accepted as a slave on the AS interface bus. This means that it is not possible to directly exchange data between two LOGO! devices. Data is always exchanged across the AS interface master.



Warning

The AS-Interface and LOGO! systems must **never** be connected together electrically!
Use safe isolation acc. to IEC 61131-2, EN 50178, UL 508, CSA C22.2 No. 142.

Logic Assignments

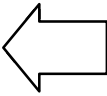
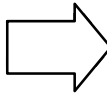
LOGO! system		AS Interface system
Inputs		Output data bits
I_n		D0
I_{n+1}		D1
I_{n+2}		D2
I_{n+3}		D3
Outputs		Output data bits
Q_n		D0
Q_{n+1}		D1
Q_{n+2}		D2
Q_{n+3}		D3

"n" depends on the plug-in position of the expansion module relative to the LOGO! Basic. It indicates the number of the input or output in LOGO! program code.

Note

Ensure that there is enough space for the inputs/outputs of the AS interface in the LOGO!'s address space. If you are already using more than 12 physical outputs or more than 20 physical inputs, it is no longer possible to operate the CM AS interface!

For detailed information about the networking of LOGO! on the AS interface bus please refer to the LOGO! CM AS Interface documentation, in particular the Micro Automation Sets 7 and 16.

2.4 Putting into operation

2.4.1 Switching on the LOGO!/Power On

LOGO! does not have a power switch. The reaction of LOGO! during startup depends on

- Whether a circuit program is stored in LOGO!
- Whether a program module (Card) is inserted
- Whether this is a LOGO! version without display unit (LOGO!...o)
- The status of LOGO! at the time of power failure.

All possible reactions of LOGO! are described on the following page.

To ensure that the expansion module on LOGO! changes to RUN mode, check the following:

- Has the sliding contact between LOGO! and the expansion module snapped into place properly?
- Is the power supply connected to the expansion module?
- In addition, always ensure that you switch on the power supply to the expansion module first before activating the power supply to the LOGO! basic module (or activate both power supplies at the same time); if you do not do this, the system does not detect the expansion module when you start up the LOGO! basic module.

Before power off

After power on

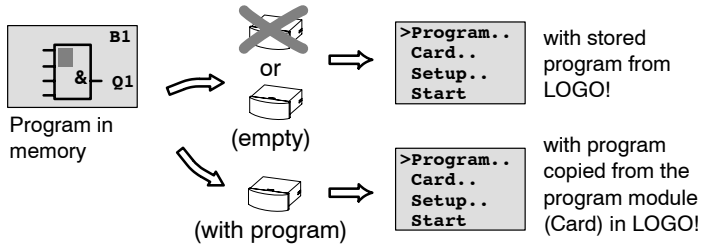
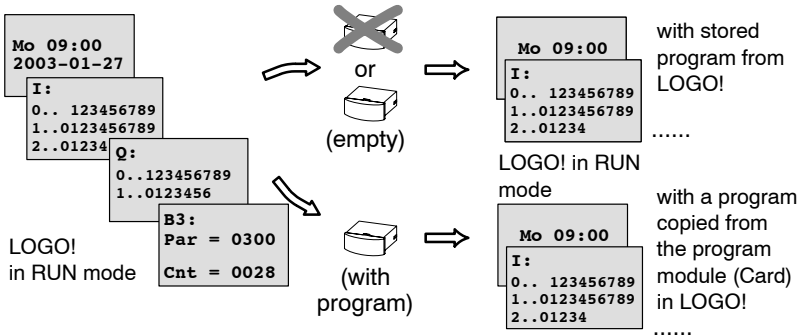
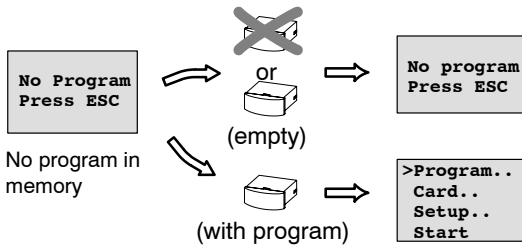

You can also memorize four simple rules for starting LOGO! :

1. If neither LOGO! nor the inserted program module (Card) contains a circuit program, LOGO! (with display unit) reports: 'No Program / Press ESC'.
2. A circuit program on the program module (Card) is automatically copied to LOGO!. The circuit program in LOGO! is overwritten.
3. If there is a circuit program in LOGO! or on the program module (Card), LOGO! adopts the operational state it had prior to POWER-OFF. Versions without display unit (LOGO!...o) automatically change from STOP to RUN (LED changes from red to green).
4. If you have enabled retentivity for at least one function, or a function is permanently retentive, the current values are retained at POWER-OFF.

Note

When a power failure occurs while you are entering a circuit program, the program in LOGO! will be deleted after power is returned.

Before you modify the circuit program, you should therefore save a backup copy of your original to a program module (Card) or to a computer (LOGO!Soft Comfort).

2.4.2 Putting into operation of CM EIB/KNX

1. Bus voltage and supply voltage must be present.
2. Connect the PC to the serial EIB interface.
3. Start software ETS, using ETS2 version 1.2.
4. Configure the application program in ETS2, V 1.2.
5. The application program is loaded into the devices via the EIB interface. The application program is available on the LOGO! home page (<http://www.siemens.de/logo>).
6. Click on "Program Physical Address" in ETS.
7. Press the button of the CM EIB/KNX to switch the CM EIB/KNX to programming mode; LED lights up orange.

Note

The button "Prog ↓" should not be pressed too firmly.
If the bus connection is OK, the LED lights up green.
In programming mode, the LED lights up orange.

8. If the LED is extinguished, the programming of the physical address has finished. You can now mark the physical address on the device. Composition of the physical address:
Area / Line / Device XX / XX / XXX
9. The application program can now be run. The device is then ready for operation.
10. If several CM EIB/KNX are installed in an EIB system, steps 1 to 9 must be repeated for each CM EIB/KNX.
11. Any further details about EIB commissioning can be found in the corresponding documentation.

2.4.3 Operating states

LOGO! Basic operating states

LOGO! Basic/Pure knows two operating states: STOP and RUN.

STOP	RUN
<ul style="list-style-type: none"> • The display shows: 'No Program' (not LOGO!...o) • Switching LOGO! to programming mode (not LOGO!...o) • LED is red (only LOGO!...o) 	<ul style="list-style-type: none"> • Display: Screen mask for monitoring I/Os and messages (after START in the main menu) (not LOGO!...o) • Switching LOGO! to parameter assignment mode (not LOGO!...o) • LED is green (only LOGO!...o)
<p>Action of LOGO!:</p> <ul style="list-style-type: none"> • The inputs data is not read. • The circuit program is not executed • The relay contacts are permanently open or the solid-state outputs are switched off 	<p>Action of LOGO!:</p> <ul style="list-style-type: none"> • LOGO! reads the status of the inputs • LOGO! uses the circuit program to calculate the status of the outputs • LOGO! switches the relay/solid-state outputs on or off

Note

After switching the mains on, the system briefly switches through the outputs on the LOGO 24/24o. With an open circuit, a voltage of > 8 V can occur for up to approximately 100 ms; when loaded, this time reduces to a matter of micro-seconds.

LOGO! expansion modules, operating states

LOGO! expansion modules know three operating states: The LED (RUN/STOP) is lit green, red or orange.

LED (RUN/STOP) is lit		
Green (RUN)	Red (STOP)	Orange/Yellow
The expansion module communicates with the device to its left	The expansion module does not communicate with the device to its left	Initialization phase of the expansion module

CM AS Interface, communication states

The CM AS Interface knows three communication states: The LED is lit green, red or flashes red/yellow.

LED AS-I is lit		
Green	Red	Red/Yellow
AS Interface communication OK	AS Interface communication failed	Slave has address "0"

CM AS Interface, behaviour on communication failure

- If the AS Interface voltage fails, communication between the LOGO! system and the expansion modules, which are arranged to the right of the LOGO! CM AS Interface expansion module, is interrupted.
Recommendation: Position LOGO! CM AS Interface on the far right-hand side!
- If communication is interrupted, the switching outputs are reset after about 40 to 100 ms.

CM EIB/KNX, communication states

The CM EIB/KNX knows three communication states: The LED is lit green, red or orange.

LED BUS is lit		
Green	Red	Orange
Bus connection OK, communication OK, no programming mode	Bus connection interrupted	Programming mode active and bus connection OK

CM EIB/KNX, behaviour on communication failure

- LOGO! voltage failure
If there is a power failure of LOGO! or a disruption in the communication to the LOGO! master or to the communication partner on the left-hand side, the outputs are set to 0. The RUN/STOP LED lights up red after a second.
- LOGO! voltage recovery
LOGO! starts up again, CM EIB/KNX sends the parameterised states.
- CM EIB/KNX voltage failure
All the inputs of the LOGO! master on the *EIB* are set to 0 by the LOGO! master.
- CM EIB/KNX voltage recovery
All the outputs of the LOGO! master on the *EIB* are updated. The inputs are read by the *EIB* depending on the parameterisation.
- Short circuit on the bus or bus interruption
The behaviour can be parameterised in the LOGO! configuration window of the application program in ETS (EIB Tool Software). The red light is set after 5 s.
- Bus recovery
The behaviour can be parameterised in the LOGO! configuration window.

3 Programming LOGO!

Getting started with LOGO!

Programming in our context refers to creating a circuit program. A LOGO! circuit program program is actually nothing more than a circuit diagram presented in a slightly different form!

We have adapted this presentation to the LOGO! display field. In this chapter we will show you how to use LOGO! to create the LOGO! circuit programs for your application.

At this point, we once again refer to LOGO!Soft Comfort, which is the LOGO! programming software you can use to quickly and easily create, test, modify save and print the circuit programs. The topics in this manual relate only to the creation of circuit programs on the actual LOGO!, because the programming software LOGO!Soft Comfort already contains extensive Online Help.

See also Chapter 7.

Note

LOGO! versions without display unit, i.e. the LOGO! 24o, LOGO! 12/24RCo, LOGO! 24RCo and LOGO! 230RCo units, do not have an operator panel and display unit. They are primarily designed for use in small machine and process equipment engineering systems for series production.

LOGO!...o versions are not programmed directly on the unit. Instead, the circuit program is downloaded to this device by means of LOGO!Soft Comfort or program modules (Cards) of other LOGO! 0BA5 units.

LOGO! versions without a display cannot write data to program modules (Cards).

See Chapters 6, 7 and Appendix C.

A small example in the first part of this chapter introduces the operating principle of LOGO!.

- We shall first show you the meaning of two basic terms, namely the **connector** and the **block**.
- As the next step, we shall create a circuit program based on a simple conventional circuit, which you ...
- can enter directly in LOGO! in the third step.

It will take you only a few pages of this manual to store your first executable circuit program in the LOGO! unit. With a suitable hardware (switches etc.), you will then be able to carry out first tests.

3.1 Connectors

LOGO! is equipped with inputs and outputs

Example of a configuration with several modules:

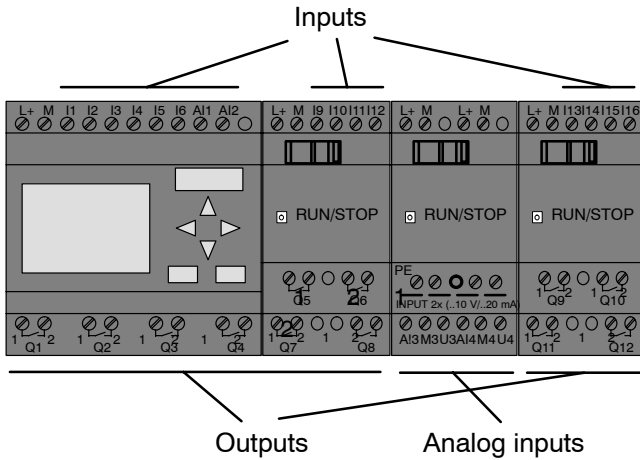

Each input is identified by the letter I plus a number. When you look at LOGO! from the front, you can see the input terminals at the top. Only analog modules LOGO! AM 2 and AM 2 PT100 have the inputs at the bottom.

Each output is identified by the letter Q plus a number (AM 2 AQ: AQ plus number). In the figure, you can see the output terminals at the bottom.

Note

LOGO! can recognize, read and switch the I/O of all expansion modules regardless of their type. The I/Os are presented in the installation order of the modules.

The following I/Os and flag blocks are available for creating your circuit program: : I1 to I24, AI1 to AI8, Q1 to Q16, AQ1 and AQ2, M1 to M24 and AM1 to AM6. Also available are the shift register bits S1 to S8, 4 cursor keys C ▲, C ►, C ▼ and C ◀, as well as 16 blank outputs X1 to X16. See Chapter 4.1 for more details.

The following applies to inputs I7 and I8 of LOGO! 12/24... and LOGO! 24/24o versions: If I7 or I8 is used in the circuit program, this input signal is digital; signals at AI1 or AI2 are analog.

LOGO!'s connectors

The term connector refers to all connections and states in LOGO! .





The digital I/O status can be '0' or '1'. Status '0' means that the input does not carry a voltage. Status '1' means that the input carries voltage.

The 'hi', 'lo' and 'x' connectors have been introduced to make it easier for you to create the circuit program:
'hi' (high) is assigned the status '1',
'lo' (low) is assigned the status '0'.

You do not have to use all of the connectors of a block. The circuit program automatically assigns the unused connectors a status that ensures proper functioning of the relevant block. If you prefer to do so, you can identify unused connectors with an 'x'.

For information on the meaning of the term "block", refer to Chapter 3.3.

LOGO! knows the following connectors:

Con-nectors	LOGO! Basic / Pure		DM	AM	AM2AQ
					
Inputs	LOGO! 230RC/RCo, LOGO! 24 RC/RCo	Two groups: I1... I4 and I5 ... I8	I9 ... I24	AI1... AI8	none
	LOGO! 12/24RC/ RCo, LOGO! 24/24o	I1... I6, I7, I8 AI1, AI2	I9 ... I24	AI3... AI8	
Outputs	Q1...Q4		Q5 ... Q16	none	AQ1, AQ2
lo	Logical '0' signals (off)				
hi	Logical '1' signals (on)				
x	An existing connection that is not used				

DM: Digital module

AM: Analog module

3.2 EIB inputs/outputs

The application program “20 CO LOGO! 900E02” controls the communication between the LOGO! and the EIB/KNX bus via the communication module CM EIB/KNX.

By configuring the application program in ETS (EIB Tool Software), the division of the input and output area of the LOGO! can be defined as a “hardware channel” and as a “virtual channel” on the EIB/KNX bus.

This characteristic also applies for analog processing.

A communication object is assigned to each “hardware channel” and each “virtual channel” of LOGO! module. The real-time clock of LOGO! can be used as a master or slave via the EIB/KNX bus.

The behaviour of the communication objects of the communication module CM EIB/KNX, when the status of the EIB/KNX bus changes, can also be parameterised.

A “virtual input channel” can be used as a bus state, i.e. a bus voltage failure can be reported.

The settings for analog values in LOGO! (Offset, Gain) do not affect the analog values for the CM EIB/KNX communication module (the output values of the CM EIB/KNX are always the raw values between 0 and 1000). In this case, you must parameterize customizing in the ETS.

Functions of the application program

- Specification of the hardware configuration (number of local digital inputs and outputs, analog inputs)
- Selection of time master or slave
- Use of I24 as a bus status signal
- Behaviour on bus voltage failure/recovery
- Input type as monoflop/normal for digital inputs via the EIB/KNX
- Output type as normal/dimmer/edge evaluation for digital outputs via the EIB/KNX

- Data type, adaptation, cyclical sending and sending on change in value for analog outputs via the EIB/KNX and analog inputs on LOGO!

Any further details about configuring the application program in ETS can be found in the current application program description.

For the application program see Siemens product database from version J onwards

or: <http://www.siemens.de/gamma>
<http://www.siemens.de/logo>

3.3 Blocks and block numbers

This chapter shows you how to use LOGO! elements to create complex circuits and how blocks and I/O are interconnected.

In Chapter 3.4 we are going to show you how to transform a conventional circuit to obtain a LOGO! circuit program.

Blocks

A block in LOGO! represents a function that is used to convert input information into output information. Previously you had to wire the individual elements in a control cabinet or terminal box.

When you create the circuit program, you interconnect the blocks. To do so, simply select the connection you require from the **Co** menu. The menu name Co is an abbreviation of the term “Connector”.

Logic operations

The most elementary blocks are the logic operations:

- AND
- OR
- ...

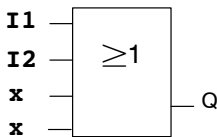

Inputs I1 and I2 are here connected to the OR block. The last two inputs of the block remain unused and are identified by the creator of the circuit program with an 'x'.

These special functions offer you significantly greater performance:

- Pulse relay
- Up/down counter
- On-delay
- Softkey
-

Chapter 4 gives a full list of the LOGO! functions.

Block representation on the LOGO! display

The figure below shows a typical view of the LOGO! display. As you can see, it can show only one block at a time. We have therefore introduced block numbers to help you check the circuit structure.

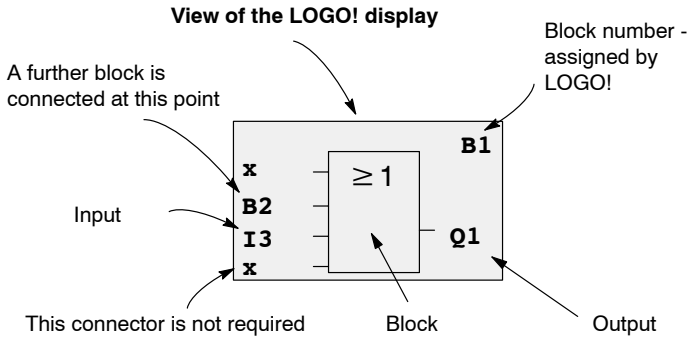

Assigning a block number

LOGO! assigns each new block in a circuit program a block number.

LOGO! uses these block numbers to indicate the block interconnections. This means that these numbers are mainly an aid to your orientation in the circuit program.

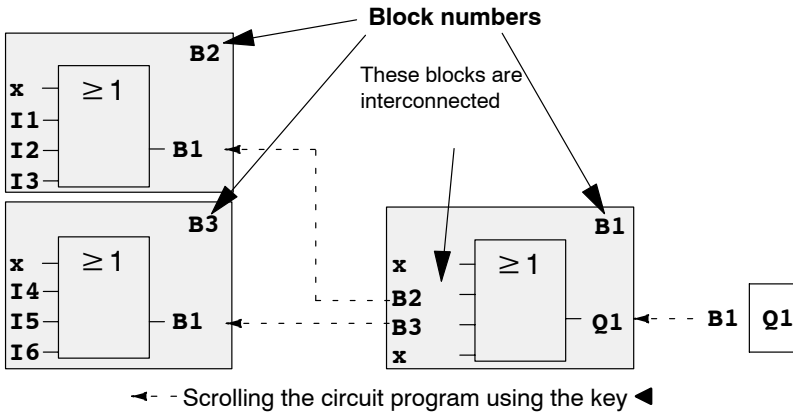

The figure above shows you three views of the LOGO! display, which represent the circuit program. As you can see, LOGO! interconnects the blocks using their numbers.

Advantages of block numbers

You can connect almost any block to an input of the current block by means of its block number. In this way, you can reuse the interim results of logical or other operations, reduce programming effort, save memory space and clean up your circuit layout. To do so, however, you need to know how LOGO! has named the blocks.

Note

We advise you to create an organizational program chart. You will find this a valuable aid when you create the circuit program because you can enter in this chart all the block numbers that LOGO! assigns.

By using the LOGO!Soft Comfort software to program LOGO!, you can directly create a function chart of your circuit program. LOGO!Soft Comfort also allows you to assign eight-character names to up to 64 blocks, and to view these on the LOGO! display in parameter assignment mode (see Chapter 3.5).

3.4 The way to LOGO!, starting with the circuit diagram

View of a circuit diagram

You know, of course, how a circuit logic is represented in a circuit diagram. Nevertheless, here is an example:

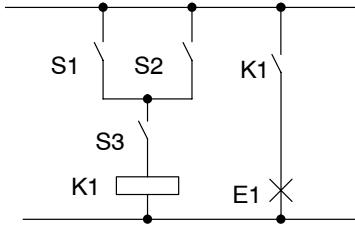

Load E1 is switched on and off by means of the switches (S1 OR S2) AND S3.

Relay K1 picks up when condition (S1 OR S2) AND S3 is met.

Creating this circuit with LOGO!

In LOGO! you create a circuit logic by interconnecting blocks and connectors:

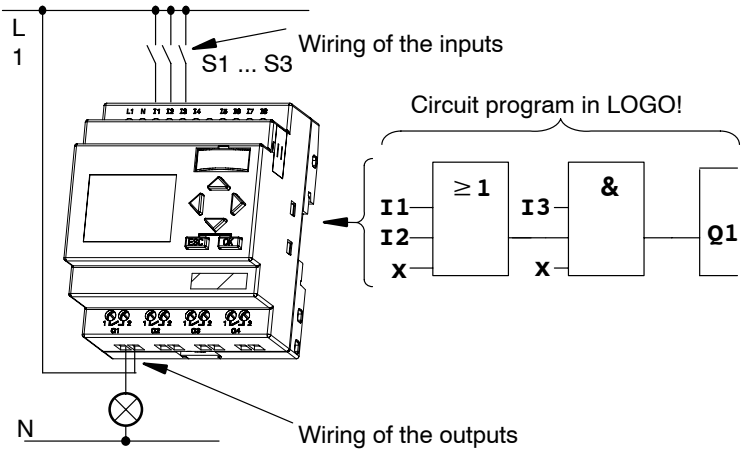

Note

Although you have four inputs available for logic operations (Basic functions, see Chapter 4.2), most of the views will only show three inputs for reasons of clarity. You program this fourth input and assign parameters just like you do with the other three inputs.

To create a circuit logic in LOGO!, start at the circuit output. The output is the load or relay that is to be switched.

Convert the circuit logic into blocks by working through the circuit, starting at the output and ending at the input:

Step 1: The make contact S3 is interconnected in series to output Q1 and to a further circuit element. A series connection corresponds with the AND block:

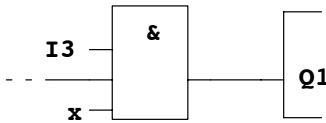

Step 2: S1 and S2 are connected in parallel. A parallel circuit corresponds with the OR block:

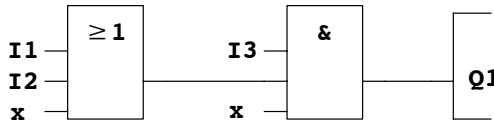

Unused inputs

The circuit program automatically assigns the unused connectors a status that ensures proper functioning of the relevant block. If you like, you can label unused connectors with an 'x' identifier.

In our example we shall use only two inputs of the OR block and two inputs of the AND block; the relevant unused third and fourth inputs are identified at the connector with an 'x'.

Now connect the I/Os to LOGO! .

Wiring

Connect the switches S1 to S3 to the screw terminals of your LOGO! :

- S1 to connector I1 of LOGO!
- S2 to connector I2 of LOGO!
- S3 to connector I3 of LOGO!

The output of the AND block controls the relay at output Q1. The load E1 is connected to output Q1.

Wiring example

The following figure shows you the wiring, based on a 230 V AC version of LOGO!.

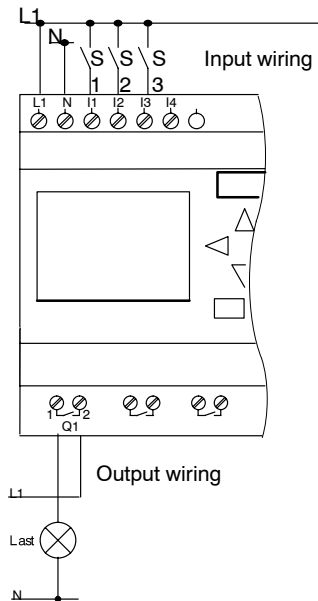

3.5 The four golden rules for operating LOGO!

Rule 1

Changing the operating mode

- You create the circuit program in **programming mode**. After power is on, and when the display shows “No Program / Press ESC”, press the **ESC** key to select programming mode.
- Timer and parameter values of an existing circuit program can be edited both in **parameter assignment mode** and in **programming mode**. During **parameter assignment** LOGO! is in **RUN mode**, i.e. it continues executing the circuit program (see Chapter 5). To work in **programming mode**, you need to terminate the circuit program by calling the “**Stop**” command.
- Select the ‘Start’ command on the main menu to set **RUN mode**.
- When the system is in **RUN**, you can return to **parameter assignment mode** by pressing the **ESC** key.
- When **parameter assignment mode** is open and you want to return to **programming mode**, select the “**Stop**” command from the parameter assignment menu, and confirm “**Stop Prg**” prompt with “**Yes**”. To do so, move the cursor to “**Yes**” and confirm with OK.

For more details on operating modes, refer to Appendix D.

Note

The following applies to 0BA2 device versions and earlier:

- You can open programming mode by pressing ◀+▶+OK.
 - You set parameter assignment mode by pressing **ESC+OK**.
-

Rule 2

Outputs and inputs

- Always create your circuit program by working from the output to the input.
- You can connect an output to several inputs, but not the same input to several outputs.
- Within the same program path you may not connect an output to an upstream input. For such internal recursions you should interconnect flags or outputs.

Rule 3

Cursor and cursor movement

The following applies when you edit a circuit program:

- You can **move the cursor** when it appears in the form of an underscore:
 - Press ◀, ▶, ▼ or ▲ to move the cursor in the circuit program.
 - Press **OK** to change to "Select connector/block"
 - Press **ESC** to exit programming mode.

- You **select a connector/block**

when the cursor appears as a solid square

- Press ▼ or ▲ to select a connector or a block.
- Confirm with OK.
- Press **ESC** to return to the previous step.

Rule 4

Planning

- Before you start to create a circuit program, you should either first create a design on paper or program LOGO! directly using LOGO!Soft Comfort.
- LOGO! can only save complete and faultless circuit programs.

3.6 Overview of LOGO! menus

Programming mode

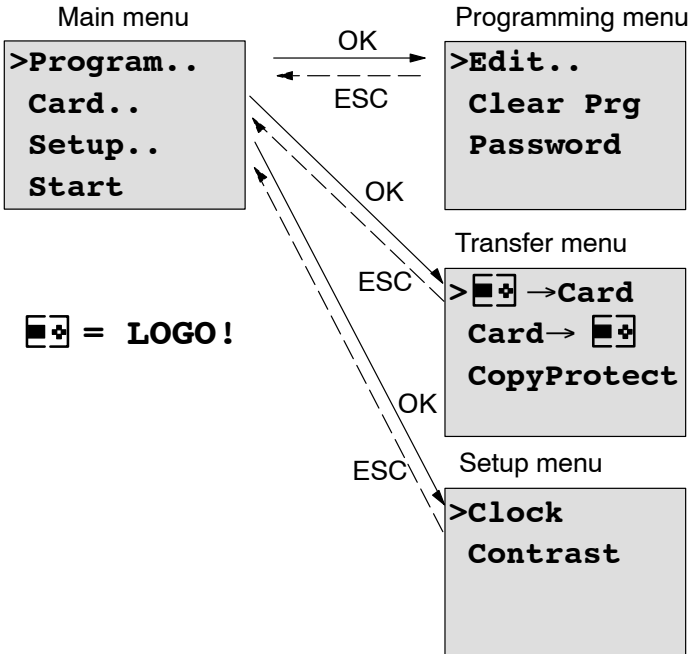

Parameter assignment mode

Parameter assignment menu

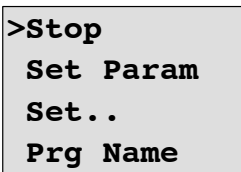

For more details on these menus, refer to Appendix D.

3.7 Writing and starting the circuit program

After you have designed a circuit, you want to write it to your LOGO! . The small example below shows how to do this.

3.7.1 Selecting programming mode

You have connected LOGO! to the power supply and switched it on. The display now shows you the message:

```
No Program
Press ESC
```

Switch LOGO! to programming mode by pressing **ESC**. This will take you to the main menu of LOGO!:

```
>Program..
  Card..
  Setup..
  Start
```

LOGO!'s main menu

The first character in the first line is the ">" cursor. Press ▲ and ▼ to move the ">" cursor up and down. Move it to "Program.." and confirm with **OK**. LOGO! opens the programming menu.

```
>Edit..
  Clear Prg
  Password
```

LOGO!'s programming menu

Here you can also move the ">" cursor by pressing ▲ and ▼. Move the ">" cursor to "Edit.." (for editing, i.e. input) and confirm with **OK**.

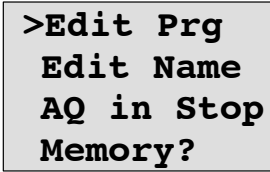

The image shows a rectangular box containing the text of the LOGO! Edit menu. The text is displayed in a monospaced font and is left-aligned. The menu items are: >Edit Prg, Edit Name, AQ in Stop, and Memory? The cursor is positioned at the beginning of the first line.

The Edit menu of LOGO!

Move the ">" cursor to "Edit Prg" (for editing the circuit program) and confirm with **OK**. LOGO! now shows you the first output:

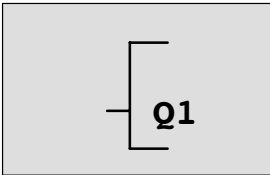

The first output of LOGO!

You are now in programming mode. Press ▲ and ▼ to select the other outputs. Now start to edit your circuit program.

Note

Because we have not yet saved a **password** for the circuit program in LOGO!, you can directly enter editing mode. When you select "Edit" after you have saved a password-protected circuit program, you are prompted to enter a password and to confirm it with **OK**. You can only edit the program after you have entered the correct password (see Chapter 3.7.5.).

3.7.2 The first circuit program

Let us now take a look at the following parallel circuit consisting of two switches.

Circuit diagram

The corresponding circuit diagram:

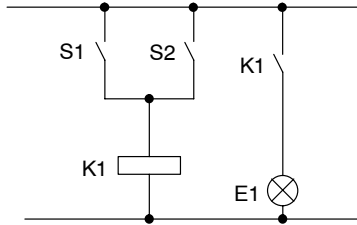

The load is switched on with S1 OR S2. LOGO! interprets this parallel circuit as an 'OR' logic, because S1 **OR** S2 switches on the output.

Translated into a LOGO! circuit program this means: Relay K1 is (at output Q1) is controlled by means of an OR block.

Circuit program

S1 is connected to the I1 and S2 to the I2 input connector of the OR block.

The corresponding layout of the circuit program in LOGO!:

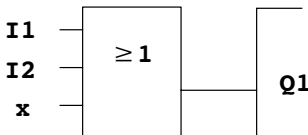

Wiring

The corresponding wiring:

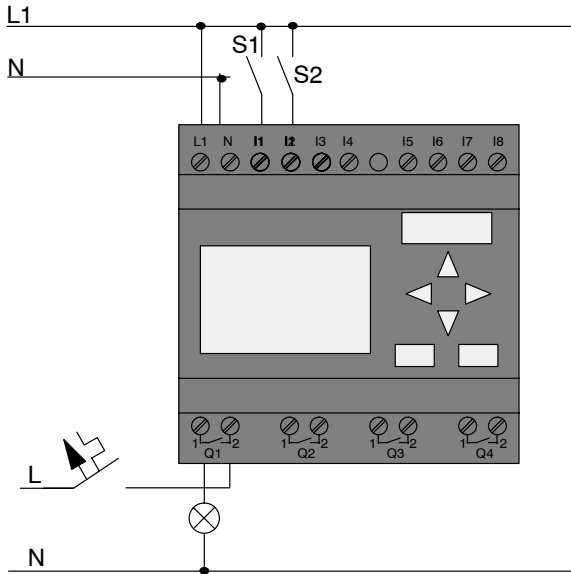

S1 switches input I1, while S2 switches input I2. The load is connected to the relay Q1.

3.7.3 Circuit program input

Let us now write the circuit program, starting at the output and working towards the input. LOGO! initially shows the output:

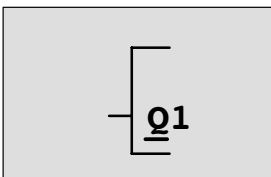

The first LOGO! output

You will see an underscore below the Q in Q1, which is the **cursor**. The cursor indicates your current position in the circuit program. You can move the cursor by pressing the ▲, ▼, ◀ and ▶ keys. Now press the ◀ key. The cursor moves to the left.

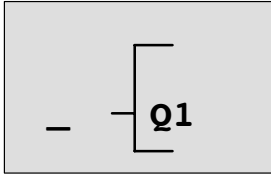

The cursor indicates your current position in the circuit program.

At this point you enter only the first (OR) block. Press **OK** to select editing mode.

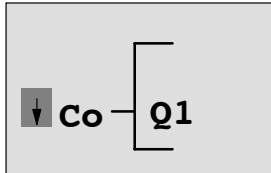

The cursor is displayed as a solid square: You can now select a connector or a block

The cursor no longer appears in the form of an underscore; but instead as a flashing solid square. LOGO! offers you various options here.

Select GF (basic functions) by pressing the ▼ key until GF appears, and confirm with **OK**. LOGO! now shows the first block from the list of basic functions:

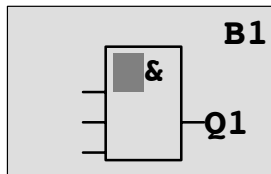

The AND is the first block of the basic functions list. The solid square cursor prompts you to select a block.

Now press ▼ or ▲ until the OR block appears on the display:

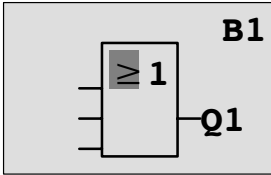

The solid square cursor is still positioned on the block.

Press **OK** to confirm your entries and exit the dialog.

The display now shows:

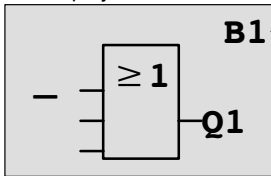

Block number

Your complete circuit program layout

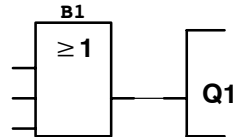

You have now entered the first block. Each new block is automatically assigned a block number. The only thing left to do is interconnect the block inputs. This is how it is done:

Press **OK**.

The display now shows:

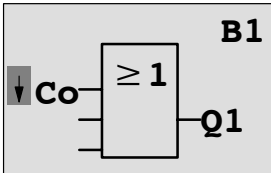

Select the **Co** list: Press **OK**

The display now shows:

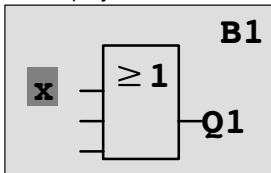

The first element of the **Co** list is the "Input 1" character, namely 'I1'.

Note

Press ▼ to go the start of the Co list: I1, I2 to I0. Press ▲ to go to the end of the Co list: I0, I1, to I1.

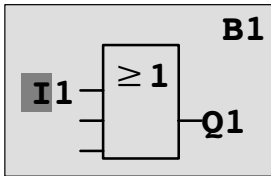

Press **OK**. I1 is now connected to the input of the OR block. The cursor jumps to the next input of the OR block.

The display now shows:

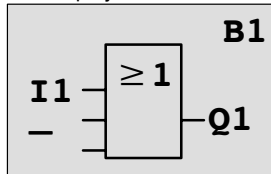

Your complete circuit program in LOGO! up to now:

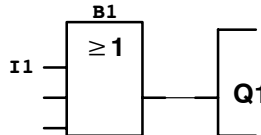

Now you connect input I2 to the input of the OR block. You already know how to do this:

- | | |
|----------------------------------|-----------------|
| 1. Switch to editing mode: | Press OK |
| 2. To select the Co list: | Press ▼ or ▲ |
| 3. To confirm the Co list with: | Press OK |
| 4. To select I2 : | Press ▼ or ▲ |
| 5. To apply I2: | Press OK |

I2 is now connected to the input of the OR block:

The display now shows:

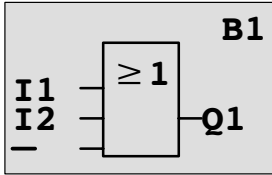

Your circuit program layout in LOGO! up to now

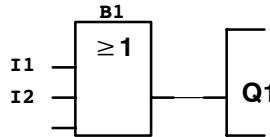

We do not need the last two inputs of the OR block for this circuit program. You can mark the unused inputs with an 'x'. Enter the 'x' character twice:

- | | |
|----------------------------------|----------------------------|
| 1. Switch to editing mode: | Press OK |
| 2. To select the Co list: | Press ▼ or ▲ |
| 3. To accept the Co list: | Press OK |
| 4. To select 'x': | Press ▼ or ▲ |
| 5. To apply x: | Press OK |

The display now shows:

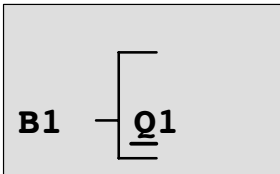

This is the layout of your circuit program

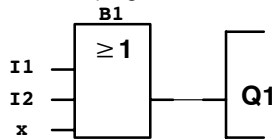

Note

You can invert individual inputs of the basic and special functions, i.e. if an input carries a logical “1” signal, the circuit program will output a logical “0”. On the other hand, a logical “0” is inverted into a logical “1” signal.

To invert an input, move the cursor to the relevant position, e.g.:

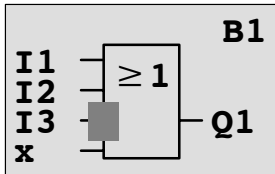

Confirm with **OK**.

Now press ▼ or ▲ to invert this input: ●

Next, press **ESC**.

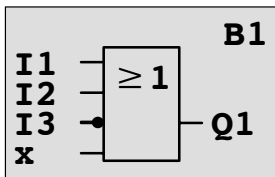

Your circuit program layout

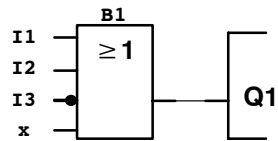

You can review your first circuit program by pressing ◀ or ▶ to move the cursor through the circuit program.

We shall now exit circuit programming mode. This is how it is done:

Return to the programming menu: Press **ESC**

Note

LOGO! has now saved your circuit program to nonvolatile memory. The circuit program remains in the LOGO! memory until you explicitly delete it.

You can save the actual values of special functions in the case of a power outage assuming that these functions support the "Retentive" parameter and that the necessary program memory is available. The Retentive parameter is deactivated in the basic status (i.e. when inserting the function). To use it, you must enable this option.

3.7.4 Assigning a circuit program name

You can assign your circuit program a name that consists of up to 16 uppercase/lowercase letters, numbers and special characters.

In the programming menu:

1. To move the ">" cursor to 'Edit..': Press ▼ or ▲
2. To accept 'Edit': Press **OK**
3. Move the ">" cursor to 'Edit Name': Press ▼ or ▲
4. To accept 'Edit Name': Press **OK**

Press ▲ and ▼ to list the alphabet from A (a) to Z (z), numbers and special characters, either in ascending or descending order. You can select any letter, number or character.

To enter a space character, simply move the cursor with ► to the next position. This character is the first one in the list.

Examples:

- Press ▼ once to select an " A "
- ▲ four times to select " { ", etc.

The following character set is available:

	A	B	C	D	E	F	G	H	I	J	K	L	M	N	O
P	Q	R	S	T	U	V	W	X	Y	Z	a	b	c	d	e

f	g	h	i	j	k	l	m	n	o	p	q	r	s	t	u
v	w	x	y	z	0	1	2	3	4	5	6	7	8	9	!
"	#	\$	%	&	'	()	*	+	,	-	.	/	:	;
<	=	>	?	@	[\]	^	_	'	{		}	~	

Let us assume you want to name your circuit program "ABC":

5. Select "A": Press ▼
6. Move to the next letter: Press ►
7. Select "B": Press ▼
8. Move to the next letter: Press ►
9. Select "C": Press ▼
10. To confirm the complete name: Press **OK**

Your circuit program is now named "ABC", and you are returned to the programming menu.

To **change** the name of your circuit program, proceed in the same way.

Note

You can change the name of the circuit program only in programming mode. You can **read** the name both in programming **and** in parameter assignment mode.

3.7.5 Password

You can protect a circuit program from unauthorized access by assigning it a password.

To assign a password

A password may have a maximum length of 10 characters, and consists only of uppercase letters (A to Z). On LOGO!, the password can be assigned, edited or deactivated only in the "Password" menu.

In the programming menu:

1. Move the ">" cursor to '**Password**': Press ▼ or ▲
2. To confirm the 'Password': Press **OK**

Press ▼ or ▲ to move up and down the alphabet to select your letters. Because LOGO! only provides uppercase letters for the password, you can quickly access letters "at the end" of the alphabet by using the ▲ button:

Press ▲ once to select "Z"

Press ▲ twice to select "Y", etc.

Let us assign the password "AA" to our first circuit program. The display now shows:

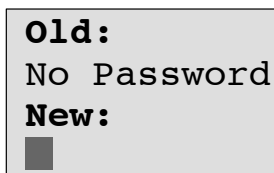

This procedure is the same as for entering the name of the circuit program. Select "New" and enter:

3. Select "A": Press ▼
4. To move to the next letter: Press ►
5. Select "A": Press ▼

The display now shows:

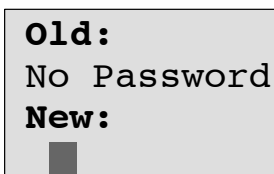

6. To confirm the password: Press **OK**

Your circuit program is now protected with the password "AA", and you are returned to the programming menu.

Note

You can cancel the input of a new password with **ESC**. In this case, LOGO! returns to the programming menu without saving the password.

You can also set your password using LOGO!Soft Comfort. You cannot edit a password-protected circuit program on LOGO! or upload it to LOGO!Soft Comfort unless you enter the correct password.

To allow you to create and edit a circuit program for a protected module (Card), you first need to assign a password to this new program (see Chapter 6.1).

Changing the password

You need to know the current password in order to change it.

In the programming menu:

1. Move the '>' cursor to **'Password'**: Press ▼ or ▲
2. To confirm the 'Password': Press **OK**

Select "Old" and enter your old password (in our case: 'AA') by repeating steps 3 through 6 as described earlier.

The display now shows:

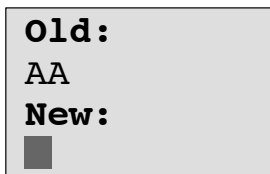

Now you can select "New" to enter the new password, e.g. "ZZ":

3. Select "Z": Press ▲
4. To move to the next letter: Press ►
5. Select "Z": Press ▲

The display now shows:

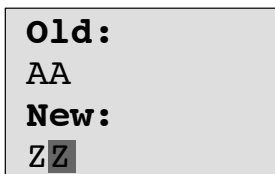

6. To confirm your new password: Press **OK**

Your new password “**ZZ**” is now set, and you are returned to the programming menu.

Deactivating the password

Let us assume you want to deactivate the password for whichever reason. For example, you want to allow another user to edit your circuit program. You must know your current password (in our example “**ZZ**”), the same as if you were changing it.

In the programming menu:

1. Move the '>' cursor to '**Password**': Press **▼** or **▲**
2. To confirm the 'Password': Press **OK**

Select “Old” and enter your current password as described in steps 3 to 5. Confirm your entries with **OK**.

The display shows:



Clear the password by leaving the input box **blank**:

3. To confirm the “blank” password: Press **OK**

The password is “cleared”, and you are returned to the programming menu.

Note

This action disables the password prompt, and thus permits access without a password.

Let the password prompt be **deactivated** for the time being, in order to accelerate progress in our further exercises and examples.

Password: Wrong Password!

When the user inputs the **wrong** password and confirms the input with **OK**, LOGO! does not open editing mode, but returns to the programming menu. This repeats itself over and over again until you input the correct password.

3.7.6 Switching LOGO! to RUN mode

In the main menu, select RUN to start LOGO!.

1. To return to the main menu: Press **ESC**
2. Move the '>' cursor to **'Start'**: Press **▲** or **▼**
3. To confirm 'Start': Press **OK**

LOGO! runs the circuit program and shows the following display:

Display field of LOGO! in RUN mode

```
Mo 09:00
2005-01-27
```

Start screen: Date and current time-of-day (only for versions with real-time clock). This element flashes if the date and time are not set.

Or: Start screen digital inputs (see Chapter 5.2.3)

◀ Press ▶

```
I:
0.. 123456789
1..0123456789
2..01234
```

← Inputs I1 to I9

← Inputs I10 to I19

← Inputs I20 to I24

◀ Press ▶

```
Q:
0.. 123456789
1..0123456
```

← Outputs Q1 to Q9

← Outputs Q10 to Q16

◀ Press ▶

```
AI:
1: 00000
2: 01000
3: 00253
```

← Analog inputs AI1 to AI3

◀ Press ▶

```
AI:
4: 00010
5: 00000
6: 00005
```

← Analog inputs AI4 to AI6

◀ Press ▶

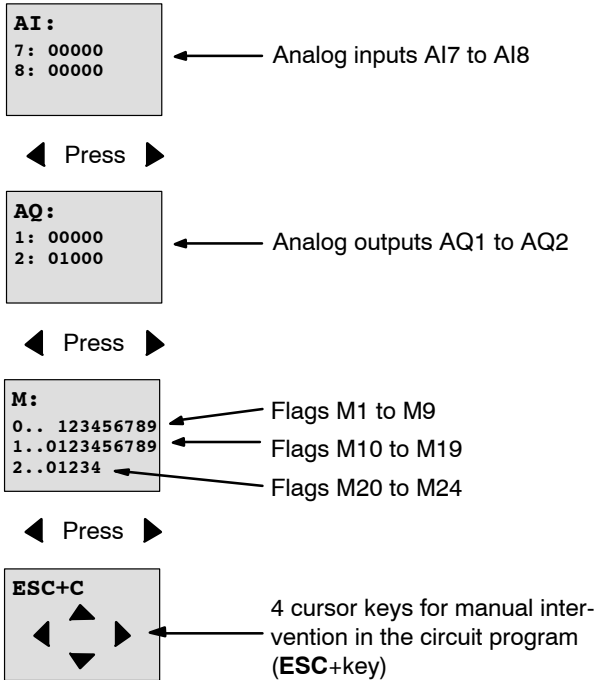

What is meant by: "LOGO! is in RUN"?

In RUN mode, LOGO! executes the circuit program. To do so, LOGO! first reads the status at the inputs, determines the status of the outputs by means of the user program, and switches these on or off according to your settings.

This is how LOGO! indicates the I/O status:

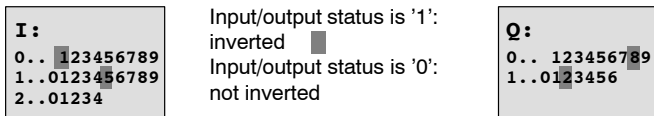

In this example, only the inputs I1, I15, Q8 and Q12 are set "high".

Status indication on the display

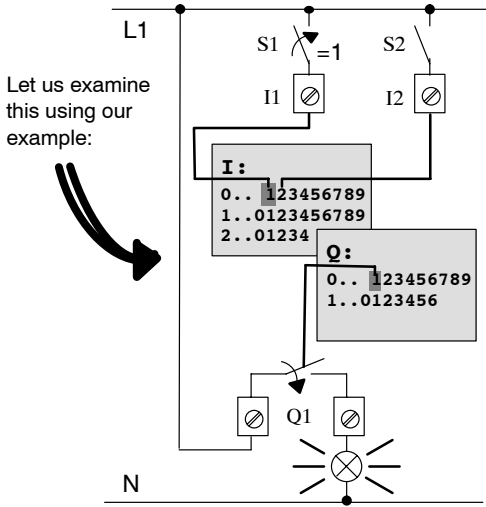

When switch S1 is closed, the status at input I1 is hi.

LOGO! computes the output states by means of the circuit program.

Output Q1 = '1', in this case.

When Q1 = '1', LOGO! sets relay Q1, and the load connected to Q1 is supplied with voltage.

3.7.7 Second circuit program

Up to this point, you have successfully created your first circuit and assigned it a name and, if desired, a password. In this section we will show you how to modify existing circuit programs and how to use the special functions.

Using this second circuit program, we will show you how to:

- Add a block to an existing circuit program.
- Select a block for a special function.
- Assign parameters.

Modifying circuits

We shall use the first circuit program as a basis for the second, with some slight modifications.

First of all take a look at the circuit diagram for the second circuit program:

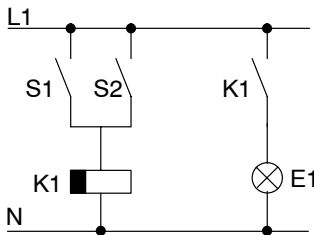

You already know the first part of the circuit. S1 and S2 switch a relay, which is to be used to switch on the load E1, and to switch off the load with a delay of 12 minutes.

This is the circuit program layout in LOGO!:

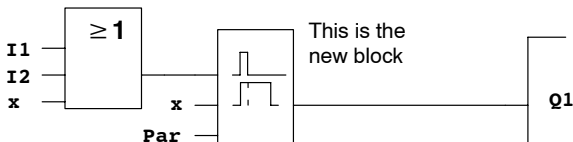

You can see the OR block and the output relay Q1 we have already used in the first circuit program. The only difference is the new off-delay block.

Editing the circuit program

Switch LOGO! to programming mode.

As a reminder:

1. Switch LOGO! to programming mode (in RUN: Press **ESC** to enter the parameter assignment mode. Select the '**Stop**' command, confirm with **OK**, then move the '>' cursor to '**Yes**', and once again confirm with **OK**). See Page 66.
2. On the main menu, select "**Program**"
3. On the Programming menu, select "**Edit**", confirm with **OK**. Next, select "**Edit Prg**" and confirm with **OK**. If required, enter your password at the prompt and confirm with **OK**.

You can now modify the current circuit program.

Adding a block to a circuit program

Move the cursor to the B in B1 (B1 is the number of the OR block):

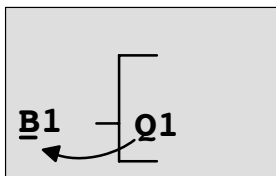

To move the cursor:
Press ◀

We now insert the new block at this position.
Confirm with **OK**.

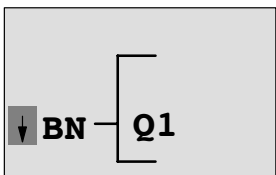

LOGO! shows you the BN list

Press ▼ to select the SF list:

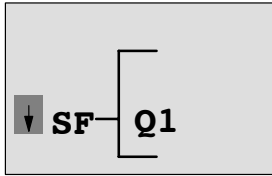

The SF list contains the special function blocks.

Press OK.

The block of the first special function is shown:

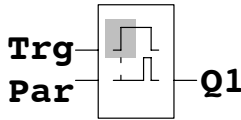

When you select a special or basic function block, LOGO! shows you the relevant function block. The solid square cursor is positioned on the block. Press ▼ or ▲ to select the required block.

Select your block (off-delay, see the next figure), and then press **OK**:

Before you press 'OK', this shows the entry **Trg**

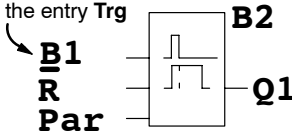

The added block is assigned the block number B2. The cursor is positioned at the top input of the added block.

The B1 block previously connected to Q1 is automatically connected to the uppermost input of the new block. Note that you can only interconnect digital inputs with digital outputs or analog inputs with analog outputs. The 'old' block will otherwise be lost.

The off-delay block has three inputs. At the top is the trigger input (Trg) you use to start the off-delay time. In our example, the OR block B1 triggers the off-delay. You reset the time and the output with a signal at the reset input. Set the off-delay time at parameter T of the input Par.

In our example we do not use the reset input of the off-delay function, and we identify it with an 'x' connector.

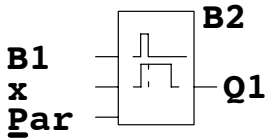

This is what the display should now show

Assigning block parameters

Now you set the off-delay time T:

1. Move the cursor to **Par**, if it not already at this position:
Press ▲ or ▼
2. Switch to editing mode: Press **OK**

LOGO! shows the parameters in the parameter assignment window:

T: The block parameter B2 is a time function

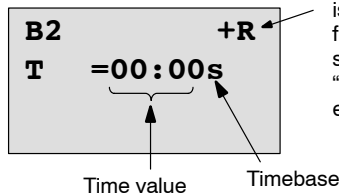

“+” means: The parameter is shown and can be modified in the parameter assignment mode.
“R” means: Retentivity is enabled for this block.

To change the time value:

- Press ◀ and ▶ to position the cursor.
- Press ▲ and ▼ to modify the value at the relevant position.
- Confirm your entries with **OK**.

Setting the time

Set the time T = 12:00 minutes:

1. Move the cursor to the first digit: Press ◀ or ▶
2. Select the digit '1': Press ▲ or ▼
3. Shift the cursor to the second digit: Press ◀ or ▶
4. Select digit '2': Press ▲ or ▼
5. Move the cursor to the unit: Press ◀ or ▶
6. Select the timebase 'm' (for minutes): Press ▲ or ▼

Showing/hiding parameters – the parameter protection mode

If you want to show/hide the parameter and allow/prevent its modification in parameter assignment mode:

1. Move the cursor to the protection mode: Press ◀ or ▶
2. Select the protection mode: Press ▲ or ▼

The display should now show:

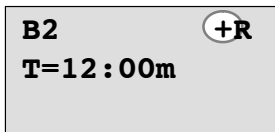

or

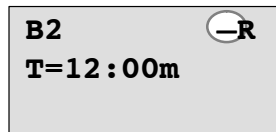

Protection mode +:

The value of the time T can be modified in parameter assignment mode

Protection mode –:

The value of the time T is hidden in parameter assignment mode

3. Confirm your entries with: **OK**

Enabling/disabling retentivity

To decide whether you want to retain your current data after a power failure or not:

1. Move the cursor to the retentivity setting: Press ◀ or ▶
2. Select the retentivity setting: Press ▲ or ▼

The display now shows:

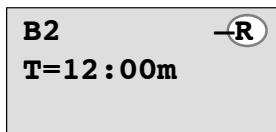

or

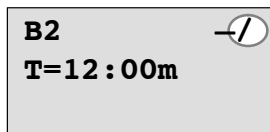

Retentivity R: Current data is retained

Retentivity /: Current data is not retained

3. Confirm your entries with **OK**

Note

For further information on the protection mode, refer to Chapter 4.3.5.

For further information on retentivity, refer to Chapter 4.3.4.

You can modify the protection mode and retentivity setting only in programming mode, i.e. this is **not** possible in parameter assignment mode.

In this manual, the protection mode ("+" or "-") and retentivity ("R" or "/") settings are only shown in the displays where these can actually be changed.

Verification of the circuit program

This program branch for Q1 is now completed. LOGO! shows you the output Q1. You can once again view the circuit program on the display. Use the keys to browse the circuit program, i.e. press ◀ or ▶ to move from block to block, ▲ and ▼ to move between the inputs at a block.

Closing the programming mode

Although you were shown how to exit the programming mode when you created your first circuit program, here is a reminder:

1. To return to the programming menu: Press **ESC**
2. To return to the main menu: Press **ESC**
3. To move the '>' cursor to '**Start**': Press **▲** or **▼**
4. To confirm '**Start**': Press **OK**

LOGO! is back in RUN mode:

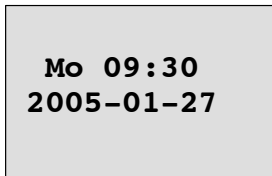

You can press ◀ or ▶ to scroll the pages and to monitor the I/O states.

3.7.8 Deleting a block

Let us assume you want to delete the block B2 from your circuit program and connect B1 directly to Q1.

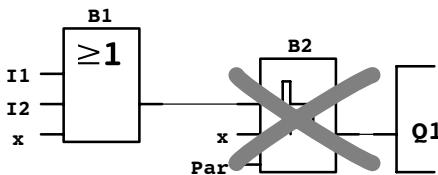

Proceed as follows:

1. Switch LOGO! to programming mode (as a reminder, refer to Page 66).
2. Select '**Edit**': Press **▲** or **▼**
3. Confirm '**Edit**': Press **OK**
(If required, enter your password and confirm with **OK**.)
4. Select '**Edit Prg**': Press **▲** or **▼**
5. Confirm '**Edit Prg**': Press **OK**

6. To move the cursor to the input of Q1, i.e. to B2, press ◀:

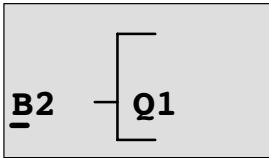

7. Confirm with **OK**.
8. Now replace block B2 with block B1 at output Q1.
The procedure:

- Select the **BN** list: Press ▲ or ▼
- Accept the BN list: Press **OK**
- Select '**B1**': Press ▲ or ▼
- Apply 'B1': Press **OK**

Result: Block B2 is deleted, because it is no longer used in the circuit. Block B1 has replaced B2 directly at the output.

3.7.9 Deleting block groups

Let us assume you want to delete the blocks B1 and B2 from the following circuit program (corresponds with the circuit program in Chapter 3.7.7).

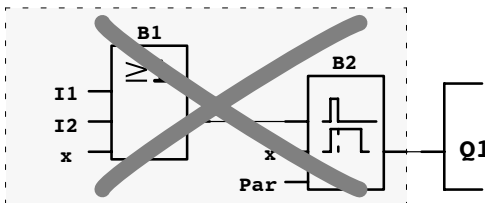

Proceed as follows:

1. Switch LOGO! to programming mode (as a reminder, refer to page 66).
2. To select '**Edit**': Press ▲ or ▼
3. To confirm '**Edit**': Press **OK**
(If required, enter your password and confirm with **OK**.)
4. To select '**Edit Prg**': Press ▲ or ▼

5. To confirm 'Edit Prg': Press **OK**
6. To move the cursor to the input of Q1, i.e. to B2, press **◀**:

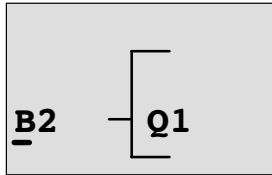

7. Confirm with **OK**.
8. Now set the connector 'x' at output Q1 instead of block B2. To do so:
 - Select the **Co** list: Press **▲** or **▼**
 - Accept the Co list: Press **OK**
 - Select '**x**': Press **▲** or **▼**
 - Apply '**x**': Press **OK**

Result: Block B2 is deleted, because it is no longer used in the circuit. This includes all blocks connected to B2. In this example, block B1 also.

3.7.10 Correcting programming errors

Programming errors can be corrected easily in LOGO! :

- Provided editing mode is not yet closed, you can revert by one step by pressing **ESC**.
- If you have already configured all inputs, simply reconfigure the faulty input:
 1. Move the cursor to the faulty position
 2. Change to editing mode. Press **OK**
 3. Enter the correct input circuit.

You can only replace a block with a block that has exactly the same number of inputs. However, you can delete the old block and then insert a new one. You can choose any new block.

3.7.11 Selecting analog output values for RUN/STOP transition

You can select the analog values that are output at the two analog outputs when LOGO! changes from RUN mode to STOP mode.

In the programming menu:

1. Move the ">" cursor to '**Edit..**': Press ▼ or ▲
2. To accept 'Edit': Press **OK**
3. Move the ">" cursor to '**AQ in Stop**': Press ▼ or ▲
4. To accept 'AQ in Stop': Press **OK**

LOGO! shows the following display:

```
>Defined
  Last
AQ in Stop
  Last
```

The current setting for the analog output channels is shown on the bottom row. The default setting is 'Last'.

You can select either 'Last' value (i.e. analog output values are held at their last value) or 'Defined' value (i.e. analog output values are set to specific values). When LOGO! changes from RUN mode to STOP mode, the values of the analog outputs change as well, depending on the setting.

5. Select the desired output setting: Press ▲ or ▼.
6. To confirm your entry: Press **OK**

Defining a specific analog output value

You want to output a specific analog value at the two analog outputs.

1. Move the '>' cursor to '**Defined**': Press ▲ or ▼
2. Confirm 'Defined': Press **OK**

The display shows:

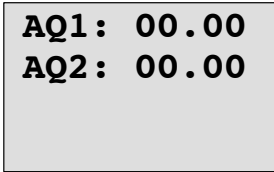

3. Enter a specific output value for each of the two analog outputs.
4. To confirm your entry: Press **OK**

3.7.12 Deleting the circuit program

To delete a circuit program:

1. Switch the LOGO! to programming mode

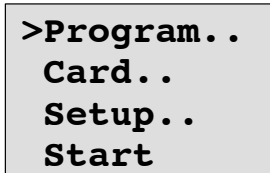

LOGO! opens the main menu

2. On the main menu, press **▲** or **▼** to move the '>' cursor to '**Program**'. Press **OK**.

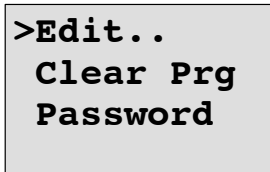

LOGO! changes to the programming menu

3. Move the '>' cursor to '**Clear Prg**': Press **▲** or **▼**
4. Confirm '**Clear Prg**': Press **OK**

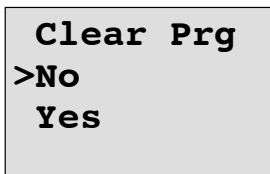

To cancel deletion of the circuit program, leave the '>' cursor at '**No**' and press **OK**.

If you are sure that you want to delete the circuit program from memory:

5. Move the '>' cursor to **Yes**: Press ▲ or ▼
6. Press **OK**.

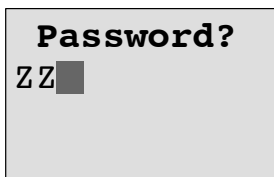

To prevent unintentional deletion of your circuit program, you are prompted to enter your password (provided you have assigned one).

7. Enter your password.
8. Press **OK**. The circuit program is deleted.

Note

Although you may have forgotten your password, you can still delete the circuit program by entering the wrong password four times.

3.7.13 Summertime/wintertime conversion

You can enable or disable automatic summertime/wintertime conversion

- in parameter assignment mode by calling the “Set..” menu command
- in programming mode by calling the “Setup” menu command.

To enable/disable automatic S/W Time conversion in programming mode:

1. Switch LOGO! to programming mode.
2. You are now in the main menu and want to select the 'Setup' menu command: Press ▲ or ▼
3. Confirm 'Setup': Press **OK**
4. Move the '>' cursor to 'Clock': Press ▲ or ▼
5. Confirm 'Clock': Press **OK**
6. Move the '>' cursor to 'S/W Time': Press ▲ or ▼
7. Confirm 'S/W Time': Press **OK**

LOGO! shows the following display:

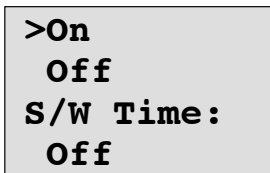

The current setting of automatic S/W Time conversion is shown on the bottom row. The default setting is 'Off': disabled.

To enable/disable automatic S/W Time conversion in parameter assignment mode:

If you want to enable/disable automatic S/W Time conversion in parameter assignment mode, select in the parameter assignment menu 'Set..', then menus 'Clock' and 'S/W Time'. You can now enable/disable automatic S/W Time conversion.

Enabling summertime/wintertime conversion

You now want to enable this conversion and define or set its parameters:

1. Move the '>' cursor to 'On': Press ▲ or ▼
2. Confirm 'On': Press **OK**

The display shows:



3. Select the desired conversion: Press ▲ or ▼

What is shown on the display ?:

- 'EU' represents the start and end of European summertime.
- 'UK' represents the start and end of summertime in the United Kingdom.
- 'US' represents the start and end of summertime in the United States.
- 'AUS' represents the start and end of Australian summertime.
- 'AUS-TAS' represents the start and end of Australian/Tasmanian summertime.
- 'NZ' represents the start and end of New Zealand summertime.
- . . . Here you can enter any month, day and time zone difference.

The preset conversion data for EU, UK and US is found in the table below:

	Start of summertime	End of summertime	Time zone difference Δ
EU	Last Sunday in March: 02:00—>03:00	Last Sunday in October: 03:00—>02:00	60 Min.
UK	Last Sunday in March: 01:00—>02:00	Last Sunday in October: 02:00—>01:00	60 Min.
US	First Sunday in April: 02:00—>03:00	Last Sunday in October: 02:00—>01:00	60 Min.
AUS	Last Sunday in October: 02:00—>03:00	Last Sunday in March: 03:00—>02:00	60 Min.

	Start of summertime	End of summertime	Time zone difference Δ
AUS-TAS	First Sunday in October: 02:00—>03:00	Last Sunday in March: 03:00—>02:00	60 Min.
NZ	First Sunday in October: 02:00—>03:00	Third Sunday in March: 03:00—>02:00	60 Min.
..	Customizing the month and the day: 02:00—>02:00 + Time zone difference	Customizing the month and the day: 03:00—>03:00 – Time zone difference	User-defined (resolution in minutes)

Note

You can specify a time zone difference Δ between 0 and 180 minutes.

Let us assume you want to enable European summertime/wintertime conversion:

4. Move the '>' cursor to 'EU': Press **▲** or **▼**
5. Confirm 'EU': Press **OK**

LOGO! shows the following display:

>On
Off
S/W Time:
On→EU

LOGO! indicates that European S/W Time conversion is enabled.

User-defined parameters

If none of the parameters/conversions apply to your country, you can customize these under menu item '...'. To do so:

1. Confirm 'On' once again: Press **OK**
2. Move the '>' cursor to '...': Press **▲** or **▼**
3. Confirm the menu item '...': Press **OK**

The display shows:

Cursor / solid square

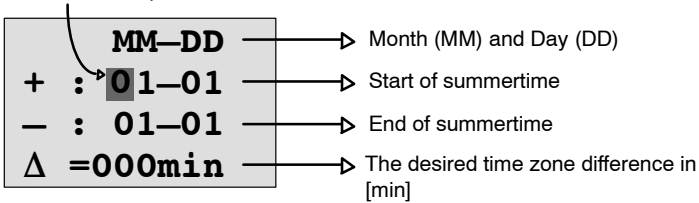

Let us assume you want to configure the following parameters: Start of summertime = 31st March, end of summertime = 1st November, time difference of 120 minutes.

This is how you can enter your data:

- Press **◀** or **▶** to move the solid square/cursor.
- Press **▲** and **▼** to change the value at the cursor position.

The display shows:

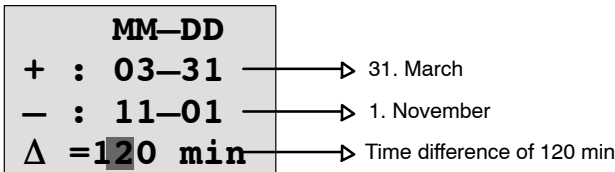

- Confirm all your entries with **OK**.

You have now customized the summertime/wintertime conversion. The LOGO! display now shows:

```
>On
  Off
S/W Time :
  On→..
```

LOGO! indicates that summertime/wintertime conversion is enabled, and that user-defined parameters ('..') have been set.

Note

To disable summertime/wintertime conversion in this menu, you merely confirm 'Off' with **OK**.

Note

Summertime/wintertime conversion only functions when LOGO! is operating (in RUN or STOP status). It does not function when LOGO! is in buffered operation (see Chapter 4.3.3).

3.7.14 Synchronization

Time synchronization between LOGO! and a connected communication module EIB/KNX (version 0AA1 upwards!) can be enabled/disabled

- in parameter assignment mode by means of the set menu ("Clock" menu item)
- in programming mode by means of the setup menu ("Clock" menu item).

When synchronization is enabled, LOGO! can receive the time-of-day from a communication module EIB/KNX (version 0AA1 upwards).

Whether synchronization is enabled or disabled, the time-of-day is always sent to the expansion modules at power-up, every hour (STOP mode or RUN mode), and when the TOD is changed (after a 'Set Clock' is executed or after a summertime/wintertime conversion).

Note

When using a LOGO! basic module with digital or analog expansion modules, but without communication module EIB/KNX (version 0AA1 upwards), time synchronization **must not** be activated! You must check whether time synchronization is deactivated ('Sync' must be set to 'Off').

To enable/disable synchronization in programming mode:

1. Switch LOGO! to programming mode.
2. You are now in the main menu, and want to select 'Setup': Press ▲ or ▼
3. Confirm 'Setup': Press OK
4. Move the '>' cursor to 'Clock': Press ▲ or ▼
5. Confirm 'Clock': Press OK
6. Move the '>' cursor to 'Sync': Press ▲ or ▼
7. Apply 'Sync': Press OK

LOGO! shows the following display:

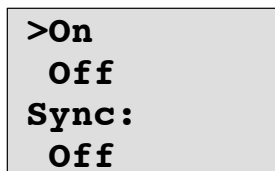

```
>On
  Off
Sync:
  Off
```

The current setting of the automatic synchronization function is displayed on the bottom row. The default setting is 'Off', i.e. disabled.

To enable/disable synchronization in parameter assignment mode:

If you want to enable/disable automatic synchronization in parameter assignment mode, select in the parameter assignment menu '**Set..**', then menus '**Clock**' and '**Sync**'. You can now enable/disable automatic synchronization.

Enabling synchronization

You want to enable synchronization:

1. Move the '>' cursor to '**On**': Press ▲ or ▼
2. Confirm '**On**': Press **OK**

LOGO! shows the following display:

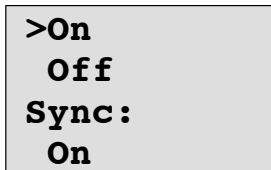

The screenshot shows a rectangular display area with a light gray background. The text is as follows:
>On
 Off
Sync:
 On

3.8 Memory space and circuit dimensions

The size of a circuit program in LOGO! is limited by the memory space (memory used by the blocks).

Memory areas

- **Program memory:**
LOGO! allows only a limited number of blocks in your circuit program.
The second limitation is based on the maximum number of bytes a circuit program may contain. The total number of bytes used can be determined by adding up the number of bytes used for the relevant function blocks.
- **Retentive memory (Rem):**
In this area, LOGO! stores process variables which need to be retentive, e.g. the hours counter value. Blocks with optional retentivity use this memory area only if this function is actually enabled.

Resources available in LOGO!

A circuit program in LOGO! can occupy the following maximum resources:

Bytes	Blocks	REM
2000	130	60

LOGO! monitors memory utilization, and offers only those functions from the lists for which it can actually provide sufficient memory space.

Memory requirements

The table below shows an overview of the memory requirements for the basic and special function blocks:

Function	Program memory	Rem memory*
Basic functions		
AND	12	–
AND with edge evaluation	12	–
NAND (not AND)	12	–
NAND with edge evaluation	12	–
OR	12	–
NOR (not OR)	12	–
XOR (exclusive OR)	8	–
NOT (Negation)	4	–
Special functions		
Times		
On-delay	8	3
Off-delay	12	3
On-/Off-delay	12	3
Retentive on-delay	12	3
Wiping relay (pulse output)	8	3
Edge triggered wiping relay	16	4
Asynchronous pulse generator	12	3
Random generator	12	–
Stairway lighting switch	12	3
Multiple function switch	16	3
Weekly timer	20	–
Yearly timer	8	–

Function	Program memory	Rem memory*
Counter		
Up/down counter	24	5
Hours counter	24	9
Threshold trigger	16	–
Analog		
Analog threshold trigger	16	–
Analog differential trigger	16	–
Analog comparator	24	–
Analog value monitoring	20	–
Analog amplifier	12	–
Analog multiplexer	20	–
Analog ramp	36	–
PI controller	40	2
Others		
Latching relay	8	1
Pulse relay	12	1
Message texts	8	–
Softkey	8	2
Shift register	12	1

*: Bytes in the Rem memory area if retentivity is enabled.

Utilization of memory areas

The system indicates that there is insufficient memory space by not allowing you to add a further block to your circuit program. LOGO! offers you only the blocks for which it can provide sufficient memory space. If LOGO! memory space is insufficient to hold any further blocks you select from a block list, the system will deny access to this list.

If memory space is fully occupied, optimize your circuit program or install a second LOGO!

Calculating memory requirements

When calculating the memory requirements of a circuit, you must always take into account all individual areas of memory.

Example:

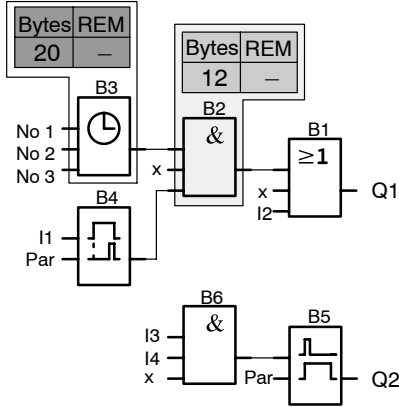

The sample circuit program contains:

Block no.	Function	Memory area		
		Bytes	Blocks	REM
B1	OR	12	1	–
B2	AND	12	1	–
B3	Weekly timer	20	1	–
B4	On-delay*	8	1	3
B5	Stairway lighting switch	12	1	0
B6	AND	12	1	–
	Resources used by the circuit program	76	6	3
	Memory space limits in LOGO!	2000	130	60
	Still available in LOGO!	1924	124	57

*: Configured with retentivity.

This means that this circuit program fits in LOGO!.

Indication of available memory space

LOGO! shows you the amount of free memory space.

Proceed as follows:

1. Switch LOGO! to programming mode
(as a reminder, refer to page 66).
2. Select '**Edit**': Press **▲** or **▼**
3. Accept '**Edit**': Press **OK**
4. Select '**Memory?**': Press **▲** or **▼**
5. Accept '**Memory?**': Press **OK**

The display now shows:

Free Memory:
Byte =1924
Block= 124
Rem = 57

4 LOGO! functions

Organization

LOGO! provides you with various elements in programming mode. In order to maintain the overview, we have organized the elements in 'Lists'. These lists are:

- ↓**Co**: Connector list (**C**onnectors)
(see Chapter 4.1)
- ↓**GF**: List of the basic functions AND, OR, ...
(refer to Chapter 4.2)
- ↓**SF**: List of the special functions
(refer to Chapter 4.4)
- ↓**BN**: List of reusable blocks configured in the circuit program

List contents

All lists show the elements available in LOGO! Usually, this includes all connectors, basic functions and special functions LOGO! knows. This includes all the blocks you have created in LOGO! by the time you call the ↓**BN** list.

If not all is shown

LOGO! does not show all elements if:

- No further blocks may be added.
This is either an indication of insufficient memory space or that the maximum number of blocks has been reached.
- A specific block's memory space requirement would exceed the space available in LOGO!

See Chapter 3.8.

4.1 Constants and connectors – Co

Constants and connectors (= Co) represent inputs, outputs, flags and constant voltage levels (constants).

Inputs:

1) Digital inputs

Digital inputs are identified with an **I**. The number of the digital inputs (I1, I2, ...) corresponds to the number of the input connectors of the LOGO! Basic and of the connected digital modules, in the order of their installation. See the figure below.

2) Analog inputs

The LOGO! versions LOGO! 24, LOGO! 24o, LOGO! 12/24RC and LOGO! 12/24RCo are equipped with the inputs I7 and I8, which can also be programmed for use as **AI1** and **AI2** inputs. Signals at the I7 and I8 inputs are interpreted as digital values, and those at the AI1 and AI2 inputs are interpreted as analog values. The inputs of a connected analog module are numbered according to the already existing analog inputs. Special functions the inputs of which should only be connected to analog inputs are offered in programming mode when you select the input signal, i.e. the analog inputs AI1...AI8, analog flags AM1...AM6, the block numbers of a function with analog output or the analog outputs AQ1 and AQ2.

Outputs:

1) Digital outputs

Digital outputs are identified by the character **Q**. The output numbers (Q1, Q2, ... Q16) correspond with the numbers of the output connectors at the LOGO! Basic and with those of the expansion modules, in their order of installation. See the following figure.

There are also 16 blank outputs available. These are identified with an **x** and cannot be reused in a circuit program (in contrast to flags, for example). The list shows all programmed blank outputs, and one blank output which is not yet configured. A blank output, for example, is useful for the special function “Message texts” (see Chapter 4.4.23), if only the message text is of significance to a circuit program.

2) Analog outputs

Analog outputs are identified by the letters **AQ**. Two analog outputs are available, namely AQ1 and AQ2. An analog output can only be connected with the analog input of a function, an analog flag AM or an analog output connector.

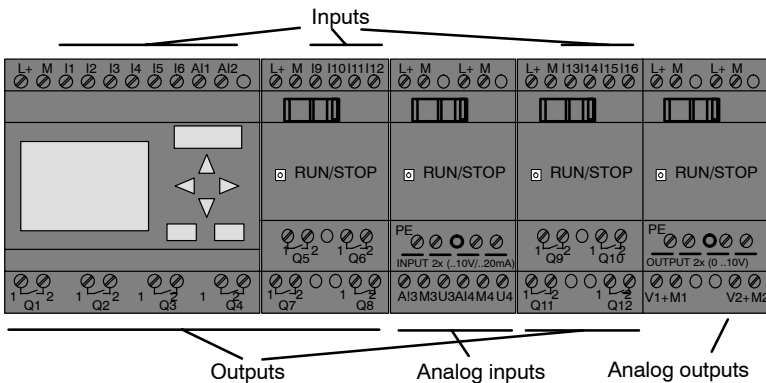

Flag blocks

Flag blocks are identified by the letters **M** or **AM**. These are virtual outputs, which output the value of their inputs. LOGO! provides 24 digital flags M1 ... M24 and 6 analog flags AM1 ... AM6.

Startup flag

Flag M8 is set in the first cycle of the user program and can thus be used in your circuit program as a startup flag. This signal is automatically reset after the circuit program has completed its first cycle.

The M8 flag can be used in all further cycles for setting, deletion and evaluation procedures in the same way as other flags.

Note

The output of the flag always carries the signal of the previous program cycle. This value does not change within the same program cycle.

Shift register bits

LOGO! provides the shift register bits S1 to S8, which are assigned the read-only attribute in the circuit program. The content of shift register bits can only be modified by means of the "Shift register" special function (see Chapter 4.4.25).

Cursor keys

Up to four cursor keys are available to you, namely C ▲, C ►, C ▼ and C ◀ ("C" = "Cursor"). Cursor keys are programmed for the circuit program in the same way as other inputs. You can set the cursor keys in the corresponding display while the system is in RUN (see Chapter 3.7.6), and in an active message text (ESC + Key). Cursor keys can save switches and inputs, and allow operator control of the circuit program.

Levels

Voltage levels are designated **hi** and **lo**. A constant "1" = hi or "0" = lo status at the block can be set by means of a permanent voltage level or constant value hi or lo.

Open connectors



Unused block connectors can be identified with an **x**.



4.2 Basic functions list – GF

Basic functions represent simple logical elements of Boolean algebra.

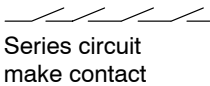
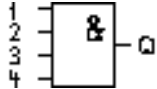
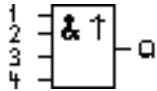
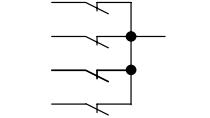
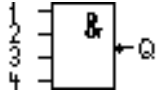
You can invert the inputs of individual basic functions, i.e. the circuit program inverts a logical “1” at a relevant input to a logical “0”; if “0” is set at the input, the program sets a logical “1”. A programming example is found in Chapter 3.7.3.

The GF list contains the basic function blocks you can use for your circuit program. The following basic functions are available:

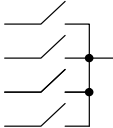
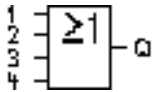
View in the circuit diagram	View in LOGO!	Name of the basic function
 <p>Series circuit make contact</p>		AND (see page 117)
		AND with edge evaluation (see page 118)
 <p>Parallel circuit with break contacts</p>		NAND (not AND) (see page 119)
		NAND with edge evaluation (see page 120)

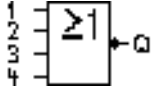
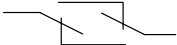
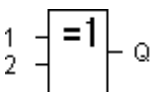
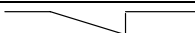
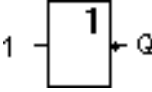
View in the circuit diagram	View in LOGO!	Name of the basic function
 <p>Parallel circuit with make contacts</p>		<p>OR (see page 121)</p>
 <p>Series circuit with break contacts</p>		<p>NOR (not OR) (see page 122)</p>
 <p>Double change-over contact</p>		<p>XOR (exclusive OR) (see page 123)</p>
 <p>Break contact</p>		<p>NOT (negation, inverter) (see page 123)</p>

4.2.1 AND

Circuit diagram of a series circuit with several make contacts:

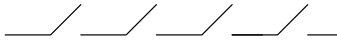

Symbol in LOGO!:

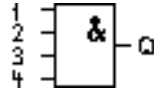

The output of the AND is only 1 if **all** inputs are 1, i.e. all contacts are closed.

At an unused block input (x): $x = 1$.

Table of the AND logic

1	2	3	4	Q
0	0	0	0	0
0	0	0	1	0
0	0	1	0	0
0	0	1	1	0
0	1	0	0	0
0	1	0	1	0
0	1	1	0	0
0	1	1	1	0
1	0	0	0	0
1	0	0	1	0
1	0	1	0	0
1	0	1	1	0
1	1	0	0	0
1	1	0	1	0
1	1	1	0	0
1	1	1	1	1

4.2.2 AND with edge evaluation

Symbol in LOGO!:

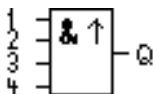

The output of an edge triggered AND is only 1 if **all** inputs are 1 and if **at least one** input was low in the previous cycle.

At an unused block input (x): $x = 1$.

Timing diagram for the AND with edge evaluation

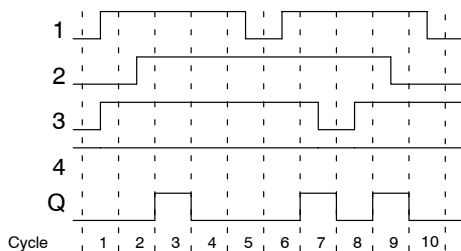

4.2.3 NAND (not AND)

Parallel circuit with multiple break contacts in the circuit diagram:

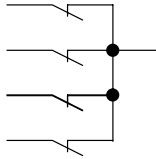

Symbol in LOGO!:

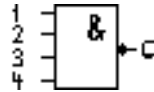

The output of the NAND is only 0 if the status at **all** inputs is 1, i.e. the contacts are closed.

At an unused block input (x): $x = 1$.

Table of the NAND logic

1	2	3	4	Q
0	0	0	0	1
0	0	0	1	1
0	0	1	0	1
0	0	1	1	1
0	1	0	0	1
0	1	0	1	1
0	1	1	0	1
0	1	1	1	1
1	0	0	0	1
1	0	0	1	1
1	0	1	0	1
1	0	1	1	1
1	1	0	0	1
1	1	0	1	1
1	1	1	0	1
1	1	1	1	0

4.2.4 NAND with edge evaluation

Symbol in LOGO!:



The output status of the NAND with edge evaluation is only 1 if **at least one** input is 0 and if **all** inputs were 1 in the previous cycle.

At an unused block input (x): $x = 1$.

Timing diagram for the NAND with edge evaluation

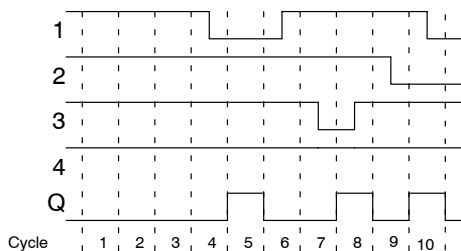

4.2.5 OR

Circuit diagram of a parallel circuit with several make contacts:

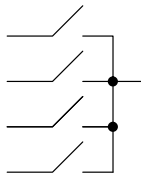

Symbol in LOGO!:

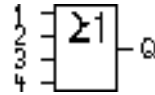

The output status of the OR element is only 1 if **at least one** input is 1, i.e. at least one of the contacts is closed.

At an unused block input (x): $x = 0$.

Table of the OR logic

1	2	3	4	Q
0	0	0	0	0
0	0	0	1	1
0	0	1	0	1
0	0	1	1	1
0	1	0	0	1
0	1	0	1	1
0	1	1	0	1
0	1	1	1	1
1	0	0	0	1
1	0	0	1	1
1	0	1	0	1
1	0	1	1	1
1	1	0	0	1
1	1	0	1	1
1	1	1	0	1
1	1	1	1	1

4.2.6 NOR (not OR)

Circuit diagram of a series circuit with several break contacts:



Symbol in LOGO!:



The output status of the NOR is only 1 if **all** inputs are 0, i.e. if switched off. The NOR output is set to 0 when one of the inputs is switched on (logical 1 status).

At an unused block input (x): x = 0.

Table of the NOR logic

1	2	3	4	Q
0	0	0	0	1
0	0	0	1	0
0	0	1	0	0
0	0	1	1	0
0	1	0	0	0
0	1	0	1	0
0	1	1	0	0
0	1	1	1	0
1	0	0	0	0
1	0	0	1	0
1	0	1	0	0
1	0	1	1	0
1	1	0	0	0
1	1	0	1	0
1	1	1	0	0
1	1	1	1	0

4.2.7 XOR (exclusive OR)

The XOR in a circuit diagram, shown as series circuit with 2 changeover contacts:

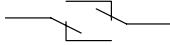

Symbol in LOGO!:

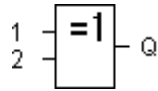

The output status of the XOR is 1 if the inputs are **not equivalent**.

At an unused block input (x): $x = 0$.

Table of the XOR logic

1	2	Q
0	0	0
0	1	1
1	0	1
1	1	0

4.2.8 NOT (Negation, Inverter)

A break contact in the circuit diagram:

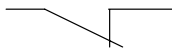

Symbol in LOGO!:

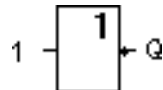

The output status is 1 if the input is 0. The NOT block inverts the input status.

Advantage of the NOT block, for example: LOGO! does not require break contacts. You simply use a make contact and the NOT block to convert these into a break contact.

Table of the NOT logic

1	Q
0	1
1	0

4.3 Basics on special functions

Because of their different input designation, you can see right away that there is a difference between the special functions and basic functions. SFs contain timer functions, retentive functions and various parameter assignment options, which allow you to adapt the circuit program to suit your own requirements.

This section provides you with a brief overview of input designations and with some particular background information on SFs. The SFs in particular are described in Chapter 4.4.

4.3.1 Designation of the inputs

Logical inputs

Here, you will find the description of the connectors you can use to create a logical link to other blocks or to the inputs of the LOGO! unit.

- **S (Set):**
A signal at input S sets the output to logical "1".
- **R (Reset):**
The reset input R takes priority over all other inputs and resets the outputs.
- **Trg (Trigger):**
This input is used to trigger the start of a function.
- **Cnt (Count):**
This input is used for counting pulses.
- **Fre (Frequency):**
Frequency signals to be evaluated are applied to this input.
- **Dir (Direction):**
This input determines the direction of count, for example.
- **En (Enable):**
This input enables a block function. When this input is "0", other signals to the block will be ignored.
- **Inv (Invert):**
A signal at this input inverts the output signal of the block.
- **Ral (Reset all):**
All internal values are reset.

Connector X at SF inputs

SF inputs connected to connector x are set low. That is, the inputs carry a 'lo' signal.

Parameter inputs

At some of the inputs you do not apply any signals. You configure the relevant block values instead. Examples:

- **Par (Parameter):**
This input will not be connected. Here, you set the relevant block parameters (times, on/off thresholds etc.).
- **No (Cam):**
This input will not be connected. Here, you configure the time patterns.
- **P (Priority):**
This is an open input. Here, you define priorities and specify whether a message is to be acknowledged in RUN.

4.3.2 Time response

Parameter T

At some of the SFs it is possible to configure a time value T. When you preset this time, note that your input values are based on the timebase set:

Timebase	__ : __
s (seconds)	seconds : ¹ / ₁₀₀ seconds
m (minutes)	minutes : seconds
h (hours)	hours : minutes

B1 +
T =04 : 10h

Setting a time T of 250 minutes:

Unit in hours h:
 04:00 hours 240 minutes
 00:10 hours ±10 minutes
 = 250 minutes

Note

Always specify a time T in ≥ 0.02 s. The time T is not defined for T < 0.02 s.

Accuracy of T

Because of slight tolerances in the characteristics of electronic components, the set time T may deviate. LOGO! has a maximum tolerance of $\pm 0.02\%$.

When 0.02% of the time T is less than 0.02 seconds, the maximum deviation is 0.02 seconds.

Example:

The maximum tolerance per hour (3600 seconds) is $\pm 0.02\%$, which is proportional to ± 0.72 seconds.

The maximum tolerance per minute (60 seconds) is ± 0.02 seconds.

Accuracy of the timer (weekly/yearly timer)

To prevent timing inaccuracy of the real-time clock in C versions caused by this deviation, the timer value is continuously compared with a high-precision timebase and corrected. The resultant maximum timing inaccuracy is ± 5 s/day.

4.3.3 Backup of the real-time clock

Because the internal real-time clock of a LOGO! is backed up, it continues operation after a power failure. The ambient temperature influences the backup time. At an ambient temperature of 25°C , the typical backup time is 80 hours. If there is a power outage of a LOGO! for more than 80 hours, the internal clock responds, dependent on the equipment series, as shown below:

- Equipment series 0BA0:
On restarting, the clock is set to "Sunday 00:00 1 January". The time starts to run. Due to this, the system processes the time switches, which trigger actions, if necessary.
- Equipment series 0BA1 and later:
On restarting, the clock is set to "Sunday 00:00 1 January". The time is stopped and flashes. LOGO! is back in the status that it was in before the power outage. In the RUN status, the system processes the counters that were parameterized with the time above. The clock is, however, still stopped.

4.3.4 Retentivity

The switching states and counter values of SFs can be set retentive. This means that current data are retained after a power failure, and that the block resumes operation at the break point. The timer is not reset, but resumes operation until the time-to-go has expired, for example.

To enable this response, however, the relevant functions must be set retentive. Two options are available:

R: The data is retained.

/: Current data is not retained (default). See the example on Page 91.

SFs hours counter, weekly timer, yearly timer and PI controller are always retentive.

4.3.5 Parameter protection

In the parameter protection settings, you can determine whether or not the parameters can be displayed and edited in LOGO! parameter assignment mode. Two options are available:

+: The parameter attribute permits read/write access in parameter assignment mode (default).

–: The parameter settings are read-/write-protected in parameter assignment mode, and can be edited only in programming mode. See the example on Page 91.

4.3.6 Calculating the gain and offset of analog values

A sensor is connected to the analog input and converts a process variable into an electrical signal. This value of signal lies within the typical range of this sensor.

LOGO! always converts the electrical signals at the analog input into digital values from 0 to 1000.

A voltage of 0 to 10 V at input AI is transformed internally into a range of values from 0 to 1000. An input voltage exceeding 10 V is shown as internal value 1000.

Because you cannot always process the range of values from 0 to 1000 as predetermined by LOGO!, you can multiply the digital values by a gain factor and then shift the zero of the range of values (offset). This allows you to output an analog value to the LOGO! display, which is proportional to the actual process variable.

Parameter	Minimum	Maximum
Input voltage (in V)	0	≥ 10
Internal value	0	1000
Gain	-10.00	+10.00
Offset	-10000	+10000

Mathematical rule

Actual value Ax =
(internal value at input Ax · gain) + offset

Gain and offset calculation

The gain and offset is calculated based on the relevant high and low values of the function.

Example 1:

The available thermocouples have the following technical data: -30 to +70°C, 0 to 10 V DC (i.e. 0 to 1000 in LOGO!).

Actual value = (internal value · gain) + offset, thus

$$-30 = (0 \cdot A) + B, \text{ i.e. offset } B = -30$$

$$+70 = (1000 \cdot A) - 30, \text{ i.e. gain } A = 0.1$$

Example 2:

A pressure sensor converts a pressure of 1000 mbar into a voltage of 0 V, and a pressure of 5000 mbar into a voltage of 10 V.

Actual value = (internal value · gain) + offset, thus

$$1000 = (0 \cdot A) + B, \text{ i.e. offset } B = 1000$$

$$5000 = (1000 \cdot A) + 1000, \text{ i.e. gain } A = 4$$

Example of analog values

Process variable	Voltage (V)	Internal value	Gain	Offset	Value shown (Ax)
-30° C	0	0	0.1	-30	-30
0° C	3	300	0.1	-30	0
+70° C	10	1000	0.1	-30	70
1000 mbar	0	0	4	1000	1000
3700 mbar	6.75	675	4	1000	3700
5000 mbar	10	1000	4	1000	5000
	0	0	0.01	0	0
	5	500	0.01	0	5
	10	1000	0.01	0	10
	0	0	1	0	0
	5	500	1	0	500
	10	1000	1	0	1000
	0	0	10	0	0
	5	500	10	0	5000
	10	1000	10	0	10000
	0	0	0.01	5	5
	5	500	0.01	5	10
	10	1000	0.01	5	15
	0	0	1	500	500
	5	500	1	500	1000
	10	1000	1	500	1500
	0	0	1	-200	-200
	5	500	1	-200	300
	10	1000	1	-200	800
	0	0	10	-10000	-10000
	10	1000	10	-10000	0
	0.02	2	0.01	0	0
	0.02	2	0.1	0	0
	0.02	2	1	0	2
	0.02	2	10	0	20

A sample application is found in the description of the “Analog comparator” SF on Page 187.

For further information on analog inputs, refer to Chapter 4.1.



4.4 Special functions list – SF



When you create your circuit program in LOGO!, you find the special function blocks in the SF list.

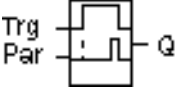
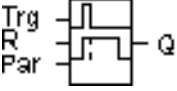
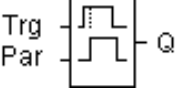
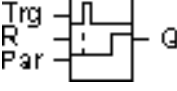
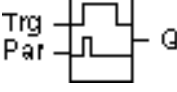

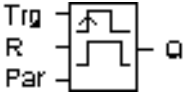
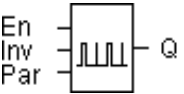
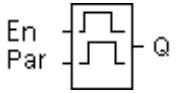
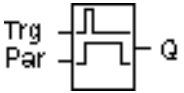
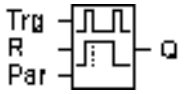
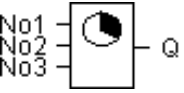

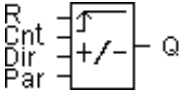
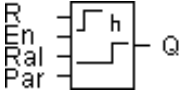
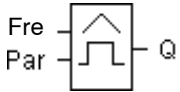
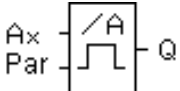
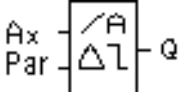

You can invert the inputs of SFs individually, i.e. the circuit program converts a logical “1” at the input into a logical “0”; a logical “0” it converts into a logical “1”. An example of the program code is found in Chapter 3.7.3.

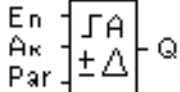
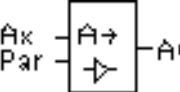
The table also specifies whether the relevant function can be set retentivity (Rem). The following SFs are available:

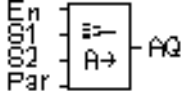
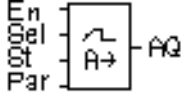
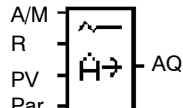
View in LOGO!	Name of the special function	Rem
Times		
	On-delay (see page 135)	REM
	Off-delay (see page 139)	REM
	On-/Off-delay (see Page 141)	REM
	Retentive on-delay (see page 143)	REM
	Wiping relay (pulse output) (see page 145)	REM

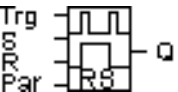
View in LOGO!	Name of the special function	Rem
	Edge triggered wiping relay (see page 147)	REM
	Asynchronous pulse generator (see Page 150)	REM
	Random generator (see page 152)	
	Stairway lighting switch (see page 154)	REM
	Multiple function switch (see page 157)	REM
	Weekly timer (see Page 160)	
	Yearly timer (see Page 165)	

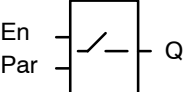
View in LOGO!	Name of the special function	Rem
Counter		
	Up/down counter (see Page 168)	REM
	Hours counter (see page 172)	REM
	Threshold trigger (see Page 177)	
Analog		
	Analog threshold trigger (see page 180)	
	Analog differential trigger (see page 183)	
	Analog comparator (see Page 187)	
	Analog value monitoring (see Page 192)	
	Analog amplifier (see Page 195)	

View in LOGO!	Name of the special function	Rem
	Analog multiplexer (see Page 216)	
	Analog ramp (see Page 220)	
	PI controller (see Page 226)	REM
Miscellaneous		
	Latching relay (see Page 198)	REM
	Pulse relay (see Page 199)	REM
	Message texts (see Page 202)	
	Softkey (see Page 209)	REM
	Shift register (see Page 213)	REM

4.4.1 On-delay

Short description

The output is only set after a configurable on-delay time has expired.

Symbol in LOGO!	Wiring	Description
	Input Trg	You start the on-delay with a negative edge (1 to 0 transition) at input Trg (Trigger).
	Parameter	T represents the time after which the output is switched on (0 to 1 transition of the output signal). Retentivity: / = no retentivity R = the status is retentive.
	Output Q	Q is switched on when the set time T has expired, provided Trg is still set.

Parameter T

Please note the defaults for parameter T in Chapter 4.3.2.

The time for parameter T can also be preset based on the actual value of another, already configured function. You can use the actual values of the following functions:

- Analog comparator (actual value $A_x - A_y$, see Chapter 4.4.18)
- Analog threshold trigger (actual value A_x , see Chapter 4.4.16)
- Analog amplifier (actual value A_x , see Chapter 4.4.20)
- Analog multiplexer (actual value A_Q , see Chapter 4.4.26)
- Analog ramp (actual value A_Q , see Chapter 4.4.27)
- PI controller (actual value A_Q , see Chapter 4.4.28) and
- Counter (actual value Cnt , see Chapter 4.4.13).

Select the required function by means of the block number.
The timebase is adjustable. Please note the following listing:

Valid ranges of the timebase, if T = parameter

Timebase	max. value	min. resolution	Accuracy
s (seconds)	99:99	10 ms	± 10 ms
m (minutes)	99:59	1s	± 1 s
h (hours)	99:59	1 min	± 1 min

The display in programming mode (example):

```

B12      +R
T   =04:10h
    
```

Valid ranges of the timebase, if T = Actual value of an already programmed function

Timebase	max. value	Meaning	Accuracy
ms	99990	Number of ms	± 10 ms
s	5999	Number of s	± 1 s
m	5999	Number of min	± 1 min

The display in programming mode (example):

```

B12      +R
T   →B006s
    
```

If the referenced block (B6, in the example) returns a value that lies out of the valid range, the value is rounded up or down to the next valid value.

Parameter preset = Actual value of an already programmed function

How to include the actual value of an already programmed function:

1. Press ► to move the cursor to the equal sign of parameter T.

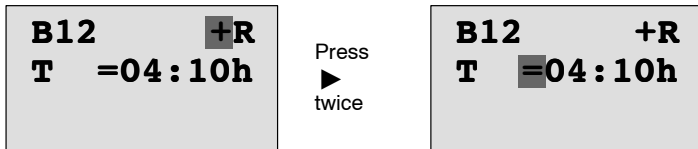

2. Press ▼ to change the equal sign into an arrow. If it exists, the last referenced block and its timebase is shown.

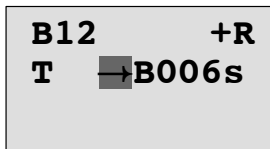

3. Press ► to move the cursor to the “B” of the shown block, and then press ▼ to select the required block number.
4. Press ► to move the cursor to the block’s timebase and press ▼ to select the required timebase.

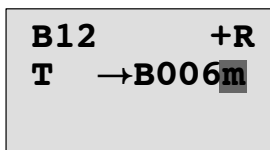

The view in parameter assignment mode (example):

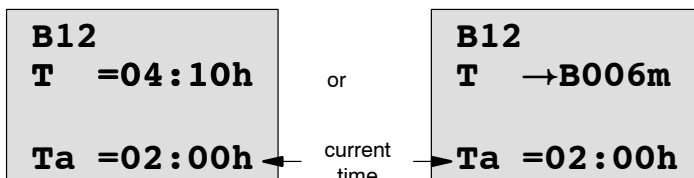

Timing diagram

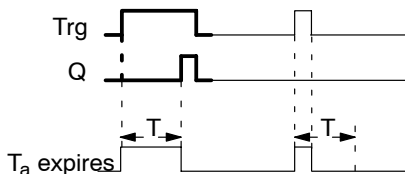

The bold section of the timing diagram is also shown in the on-delay icon.

Functional description

The time T_a is triggered with a 0 to 1 transition at input Trg (T_a is the current LOGO! time).

If the status of input Trg is 1 at least for the duration of the configured time T, the output is set to 1 on expiration of this time (the output follows the input with on-delay).

The time is reset when the status at input Trg returns to 0 before the time T has expired.

The output is reset to 0 when the signal at input Trg is 0.

If retentivity is not set, output Q and the expired time are reset after a power failure.

4.4.2 Off-delay

Short description

When an on-delay is set, the output is reset when the configured time has expired.

Symbol in LOGO!	Wiring	Description
	Input Trg	You start the off-delay time with a negative edge (1 to 0 transition) at input Trg (Trigger)
	Input R	A signal at input R resets the on-delay time and the output.
	Parameter	T is the time that expires after which the output is switched off (1 to 0 transition of the output signal). Retentivity: / = No retentivity R = The status is retentive.
	Output Q	Q is set with a signal at input Trg. It holds this state until T has expired.

Parameter T

Please note the parameter T defaults specified in Chapter 4.3.2.

The time for parameter T can be based on the actual value of another, already configured function. You can use the process variables of the following functions:

- Analog comparator (actual value $A_x - A_y$, see Chapter 4.4.18)
- Analog threshold trigger (actual value A_x , see Chapter 4.4.16)

- Analog amplifier (actual value Ax, see Chapter 4.4.20)
- Analog multiplexer (actual value AQ, see Chapter 4.4.26)
- Analog ramp (actual value AQ, see Chapter 4.4.27)
- PI controller (actual value AQ, see Chapter 4.4.28) and
- Up/down counter (actual value Cnt, see Chapter 4.4.13).

Select the required function by means of the block number. The timebase is configurable. For information on valid timebase ranges and parameter preset, refer to Chapter 4.4.1.

Timing diagram

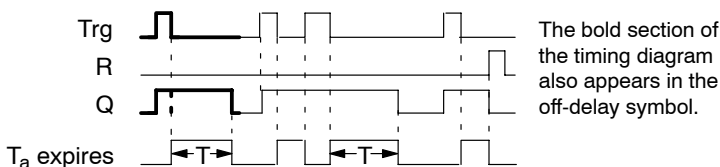

Functional description

Output Q is set to hi immediately when the input Trg changes to hi.

The actual time T_a in LOGO! is retrigged at the 1 to 0 transition of Trg. The output remains set. Output Q is reset to 0 with off-delay when T_a reaches the value configured at T ($T_a=T$).

The time T_a is retrigged with a one-shot at input Trg.

You can set input R (Reset) to reset the time T_a and the output before T_a has expired.

If retentivity is not set, output Q and the expired time are reset after a power failure.

4.4.3 On-/Off-delay

Short description

The on-/off-delay function sets the output after the set on-delay time has expired, and resets it upon expiration of the off-delay time.

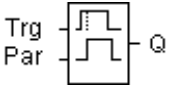
Symbol in LOGO!	Wiring	Description
 <p>The symbol shows a rectangular box with two input terminals on the left labeled 'Trg' and 'Par', and one output terminal on the right labeled 'Q'. Inside the box, there are two waveforms: a square wave above and a square wave below. The top waveform has a rising edge followed by a horizontal line, representing a delay. The bottom waveform has a falling edge followed by a horizontal line, representing a delay.</p>	Input Trg	<p>A positive edge (0 to 1 transition) at input Trg (Trigger) triggers the on-delay time T_H.</p> <p>A negative edge (1 to 0 transition) at input Trg (Trigger) triggers the off-delay time T_L.</p>
	Parameter	<p>T_H is the time after which the output is set hi (output signal transition 0 to 1).</p> <p>T_L is the time after which the output is reset (output signal transition 1 to 0).</p> <p>Retentivity: / = No retentivity R = The status is retentive.</p>
	Output Q	<p>Q is set when the configured time T_H has expired and Trg is still set. It is reset on expiration of the time T_L, if the trigger Trg has not been set again.</p>

Parameters T_H and T_L

Note the preset values for the parameters T_H and T_L in Chapter 4.3.2.

Timing diagram

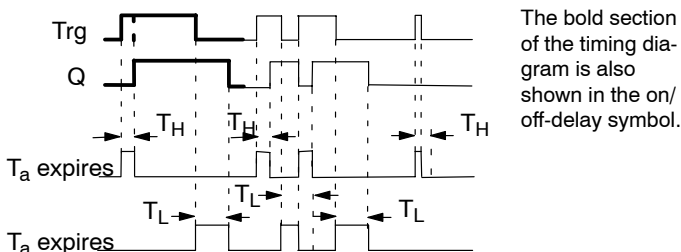

Functional description

The time T_H is triggered with a 0 to 1 transition at input Trg. If the status at input Trg is 1 at least for the duration of the time T_H , the output is set to 1 on expiration of the time T_H (the output follows the input with on-delay).

The time is reset when the signal at input Trg is reset to 0 before the time T_H has expired..

A 1 to 0 transition at input Trg triggers the time T_L .

If the status at input Trg is 0 at least for the duration of the signal T_L , the output is set to 0 on expiration of the time T_L (the output follows the input with off-delay).

The time is reset when the signal at input Trg changes to 1 again before the time T_L has expired.

If retentivity is not set, output Q and the expired time are reset after a power failure.

4.4.4 Retentive on-delay

Short description

A one-shot at the input triggers a configurable on-delay time. The output is set when this time has expired.

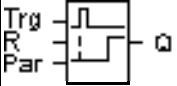
Symbol in LOGO!	Wiring	Description
	Input Trg	A signal at input Trg (Trigger) triggers the on-delay time.
	Input R	A signal at input R resets the on-delay time and the output.
	Parameter	T represents the on-delay time for the output (output status transition 0 to 1). Retentivity: / = no retentivity R = The status is retentive.
	Output Q	Q is set after the time T has expired.

Parameter T

Note the defaults specified in Chapter 4.3.2.

The time for parameter T can be based on the process variable of another, already programmed function. You can use the process variables of the following functions:

- Analog comparator (actual value Ax - Ay, see Chapter 4.4.18)
 - Analog threshold trigger (actual value Ax, see Chapter 4.4.16)
 - Analog amplifier (actual value Ax, see Chapter 4.4.20)
 - Analog multiplexer (actual value AQ, see Chapter 4.4.26)
 - Analog ramp (actual value AQ, see Chapter 4.4.27)
 - PI controller (actual value AQ, see Chapter 4.4.28)
- and

- Up/down counter (actual value Cnt, see Chapter 4.4.13).

Select the required function by means of the block number. The timebase is configurable. For information on valid ranges and parameter defaults, refer to Chapter 4.4.1.

Timing diagram

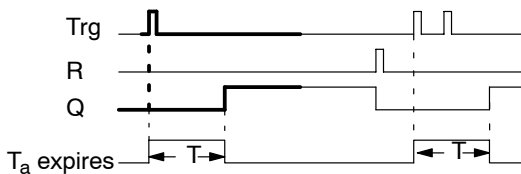

The bold section of the timing diagram is also shown in the symbol of the retentive on-delay.

Functional description

The 0 to 1 signal transition at input Trg triggers the current time T_a . Output Q is set when $T_a = T$. A further signal at input Trg does not influence the time T_a .

The output and the time T_a are reset with the next 1 signal at input R.

If retentivity is not set, output Q and the expired time are reset after a power failure.

4.4.5 Wiping relay (pulse output)

Short description

An input pulse generates a signal with a configurable period at the output.

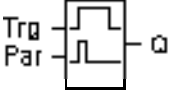
Symbol in LOGO!	Wiring	Description
	Input Trg	A signal at input Trg (Trigger) triggers the time for the wiping relay function.
	Parameter	The output is switched off after the time T has expired (output signal transition 1 to 0). Retentivity: / = No retentivity R = The status is retentive.
	Output Q	A signal at input Trg sets Q. If the input signal = 1, output Q remains set for the time T_a .

Parameter T

Please note the information on parameter T in Chapter 4.3.2.

Timing diagram

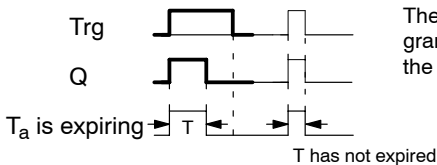

The bold section of the timing diagram also appears in the symbol of the wiping relay.

Functional description

A 0 to 1 transition at input Trg sets the output, and triggers a time T_a during which the output remains set.

Output Q is reset to lo (pulse output) when T_a reaches the value preset at T ($T_a = T$).

The output is immediately reset if there is a 1 to 0 transition at input Trg before the specified time has expired.

If retentivity is not set, output Q and the expired time are reset after a power failure.

4.4.6 Edge triggered wiping relay

Short description

An input pulse generates a preset number of output pulses with a defined pulse/pause ratio (retriggerable), after a configured delay time has expired.

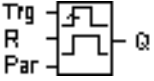
Symbol in LOGO!	Wiring	Description
	Input Trg	A signal at input Trg (Trigger) triggers the times for the edge triggered wiping relay.
	Input R	A signal at input R resets the current time (T_a) and the output.
	Parameter	<p>The interpulse width T_L and the pulse width T_H are configurable.</p> <p>N determines the number of pulse/pause cycles TL/TH: Range of values: 1...9</p> <p>Retentivity: / = No retentivity R = The status is retentive.</p>
	Output Q	Q is set after T_L has expired, and reset after T_H has expired.

Parameter T

Please note the information on parameter T in Chapter 4.3.2.

Timing diagram A

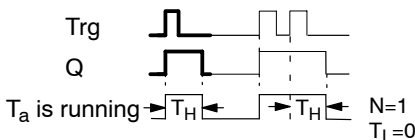

The bold section of the timing diagram also appears in the symbol of the edge triggered wiping relay.

Timing diagram B

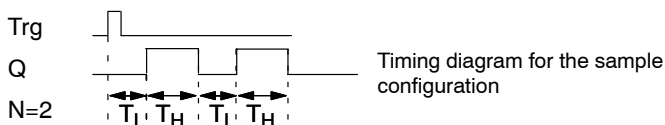

Functional description

A 0 to 1 transition at input Trg triggers the time T_L (Time Low). After the time T_L has expired, output Q is set for the duration of T_H (Time High).

If there is a further 0 to 1 transition (retriggering pulse) at input Trg before the preset time ($T_L + T_H$) has expired, T_a is reset and the pulse/pause cycle is restarted.

If retentivity is not set, output Q and the time are reset after a power failure.

Preset of the Par parameter

View in programming mode (example):

B25	1+R	← Protection mode and retentivity
TL	=02:00s	← Interpulse width
TH	=03:00s	← Pulse width

Press ►

B25	2	
N	=1	← Number of pulse/pause cycles (example)

View in parameter assignment mode (example):

B25	
TL =02:00s	
TH =03:00s	
Ta =01:15s	← Current pulse width T_L or T_H

4.4.7 Asynchronous pulse generator

Short description

The output pulse shape can be modified by reconfiguring the pulse/pause ratio.

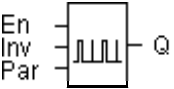
Symbol in LOGO!	Wiring	Description
	Input En	You can use input EN to set and reset the asynchronous pulse generator.
	Input INV	Input INV can be used to invert the output signal of the active asynchronous pulse generator.
	Parameter	You can configure the pulse width T_H and the interpulse width T_L . Retentivity: / = No retentivity R = The status is retentive.
	Output Q	Q is set and reset cyclically according to the pulse/pause ratio T_H and T_L .

Timing diagram

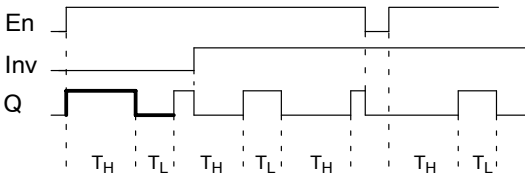

Functional description

You can configure the pulse/interpulse width at the T_H (Time High) and T_L (Time Low) parameters.

Input Inv can be used to invert the output signal, provided the block is enabled with a signal at input EN.

If retentivity is not set, output Q and the expired time are reset after a power failure.

4.4.8 Random generator

Short description

The output of the random generator is set or reset within a configured time.

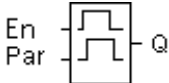
Symbol in LOGO!	Wiring	Description
	Input En	<p>A positive edge (0 to 1 transition) at input En (Enable) triggers the on-delay time of the random generator.</p> <p>A negative edge (1 to 0 transition) at input En (Enable) triggers the off-delay time of the random generator.</p>
	Parameter	<p>The on-delay is set at random to a value between 0 s and T_H.</p> <p>The off-delay is set at random to a value between 0 s and T_L.</p>
	Output Q	<p>Output Q is set when the on-delay has expired and if En is still set. It is reset when the off-delay has expired, provided En was not set again meanwhile.</p>

Parameter T_H and T_L

Note the defaults of the T_H and T_L parameters listed in Chapter 4.3.2.

Timing diagram

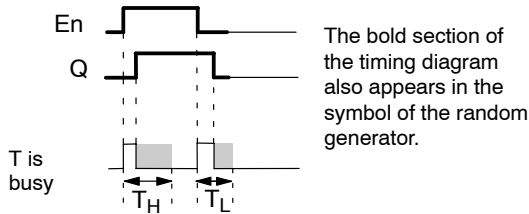

Functional description

The 0 to 1 transition at input En triggers a random on-delay time between 0 s and T_H . The output is set when the on-delay time has expired and if the signal at input En remains hi at least for the duration of this time.

The time is reset if input En is reset before the on-delay time has expired.

A 1 to 0 transition at input EN triggers a random on-delay time between 0 s and T_L .

The output is reset after the off-delay time has expired, provided input En remains lo at least for the duration of this time.

The time is reset if the signal at input En changes to 1 again before the off-delay time has expired.

The time expired is reset after a power failure.

4.4.9 Stairway lighting switch

Short description

An input edge triggers a configurable and retriggerable time. The output is reset after this time has expired. A warning signal can be output before this time has expired to warn of the impending shutdown.

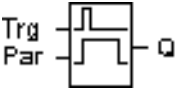
Symbol in LOGO!	Wiring	Description
	Input Trg	A signal at input Trg (Trigger) triggers the off-delay time for the stairway lighting switch.
	Parameter	<p>T represents the off-delay time of the output (output signal transition 1 to 0).</p> <p>T_I determines the triggering time for the pre-warning.</p> <p>T_{IL} determines the length of the pre-warning signal.</p> <p>Retentivity: / = No retentivity R = The status is retentive.</p>
	Output Q	Q is reset after the time T has expired. A warning signal can be output before this time has expired.

Timing diagram

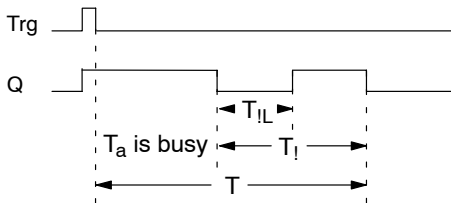

View in parameter assignment mode (example):

B9	1
T	=60:00s
Ta	=06:00s ← Current value of T

4.4.10 Multiple function switch

Short description

Switch with two different functions:

- Pulse switch with off-delay
- Switch (permanent lighting)

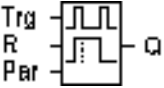
Symbol in LOGO!	Wiring	Description
	Input Trg	A signal at input Trg (Trigger) sets output Q (permanent light) or resets it with off-delay. When active, output Q can be reset with a signal at input Trg.
	Input R	A signal at input R resets the current time T_a and the output.
	Parameter	<p>T represents the time after which the output is reset (output signal transition 1 to 0).</p> <p>T_L represents the time during which the output must be set to enable the permanent lighting function.</p> <p>T_I represents the preset time for the start of the off-warning signal.</p> <p>T_{IL} represents the length of the off-warning period.</p> <p>Retentivity: / = No retentivity R = The status is retentive.</p>
	Output Q	A signal at Trg switches on output Q. Depending on the length of the input at Trg, the output is switched off again or switched on permanently, or it is reset with a further signal at Trg.

Timing diagram

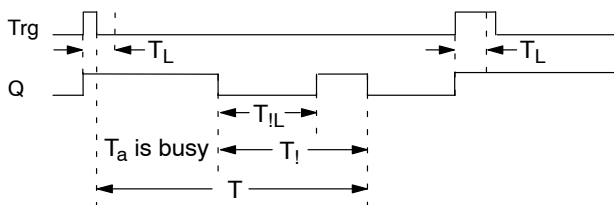

Functional description

A 0 to 1 transition at input Trg sets output Q.

If output Q = 0, and input Trg is set hi at least for the duration of T_L , the permanent lighting function is enabled and output Q is set accordingly.

The off-delay T is triggered when input Trg returns to 0 before T_L has expired.

Output Q is reset when $T_a = T$.

You can output an off-warning signal prior to the expiration of the off-delay time ($T - T_I$), to reset Q for the duration of the off-warning signal T_{IL} . A further signal at Trg always resets T and the output Q.

If retentivity is not set, output Q and the expired time are reset after a power failure.

Preset of the Par parameter

Note the defaults specified in Chapter 4.3.2.

Note

T, T_I and T_{IL} must all have the same timebase.

View in programming mode (example):

B5	1+R	← Protection mode and retentivity
T	=60:00s	← Off-delay
TL	=10:00s	← Permanent light on-time

Press ►

B5	2	
T!	=30:00s	← Start of the off-warning period ($T - T_L$)
T!L	=20:00s	← Off-warning time

View in parameter assignment mode (example):

B5	1	
T	=60:00s	
TL	=10:00s	
Ta	=06:00s	← Current value of the time T_L or T

4.4.11 Weekly timer

Short description

The output is controlled by means of a configurable on/off date. The function supports any combination of weekdays. You select the active weekdays by hiding the inactive days.

Note

Because the LOGO! 24/24o does not have a real-time clock, the weekly timer function is not available for this version.

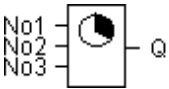
Symbol in LOGO!	Wiring	Description
	Cam parameters No1, No2, No3	At the Cam parameters, you set the on- and off-times of the weekly timer for each Cam switch. Here you also configure the days and the time-of-day.
	Output Q	Q is set when the configured cam is actuated.

Timing diagram (three examples)

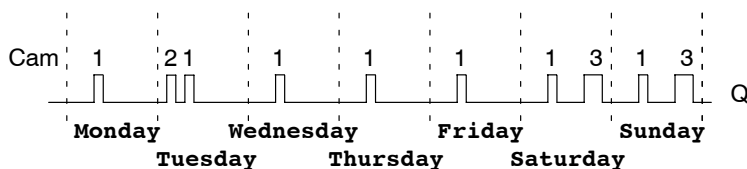

Cam No1:	Daily:	06:30 h to 08:00 h
Cam No2:	Tuesday:	03:10 h to 04:15 h
Cam No3:	Saturday and Sunday:	16:30 h to 23:10 h

Functional description

Each weekly timer has three cams you can use to configure a time hysteresis. You specify the on- and off-times at the Cam parameters. The weekly timer sets the output at a certain on-time, if this is not already set.

The weekly timer resets the output at a certain off-time, if it is not switched off already. You will cause a conflict if the on- and off-times you set for the weekly timer are identical, though set on different cams. In this case, cam3 takes priority over cam2, whereas cam2 takes priority over cam1.

The switching state of the weekly timer is determined by the status of all three cams.

Parameter assignment screen form

View of the parameter assignment screen form, for example for Cam1:

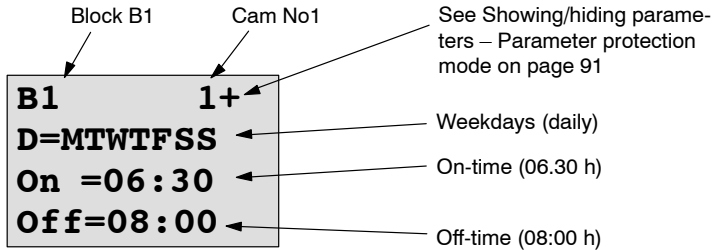

Weekday

The suffix of “D=” (Day) has the following meaning:

- M : Monday
- T : Tuesday
- W : Wednesday
- T : Thursday
- F : Friday
- S : Saturday
- S : Sunday

The uppercase letter indicates: A weekday is selected. A “_” means: A weekday has not been selected.

On-/Off-times

Any time between 00:00 h and 23:59 h is possible.

—:— means: No on-/off-times set.

Setting the weekly timer

To set the on-/off-times:

1. Move the cursor to one of the Cam parameters of the timer (e.g. No1).
2. Press **OK**. LOGO! opens the Cam parameter assignment screen form. The cursor is positioned on the weekday.
3. Press **▲** and **▼** to select one or several weekdays.
4. Press **▶** to move the cursor to the first position of the on-time.
5. Set the on-time.
Modify the value at the respective position, using the keys **▲** and **▼**. Move the cursor to the various positions, using the keys **◀** and **▶**. At the first position, you can only select the value —:—
(—:— means: No on-/off-times set).
6. Press **▶** to move the cursor to the first position of the off-time.
7. Set the off-time (in same way as in step 5).
8. Confirm your entries with **OK**.
The cursor is now positioned on the No2 parameter (Cam2) and you can configure a further cam.

Note

For information on timer accuracy, refer to the technical data and to Chapter 4.3.2.

Weekly timer: Example

The output of the weekly timer switch is to be set daily from 05:30 h to 07:40 h. The output should also be set every Tuesday from 03:10 h to 04:15 h, and at the weekends from 16:30 h to 23:10 h.

This requires three cams.

Here are the parameter assignment screen forms of the cams No 1, 2 and 3, based on the timing diagram shown earlier.

Cam1

Cam No1 must set the output of the weekly timer daily from 05:30 h to 07:40 h.

B1	1+
D=MTWTFSS	
On =05:30	
Off=07:40	

Cam2

Cam No2 must set the output of the weekly timer every Tuesday from 03:10 h to 04:15 h.

B1	2
D=-T-----	
On =03:10	
Off=04:15	

Cam3

Cam No3 must set the output of the weekly timer switch every Saturday and Sunday from 16:30 h to 23:10 h.

B1	3
D=	SS
On	=16:30
Off	=23:10

Result

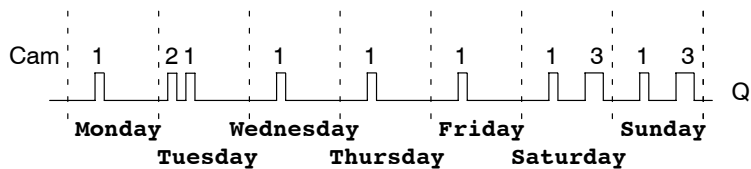

4.4.12 Yearly timer

Short description

The output is controlled by means of a configurable on/off date.

Note

Because LOGO! 24/24o does not have a real-time clock, the yearly timer is not available for this version.

Symbol in LOGO!	Wiring	Description
No  Q	Cam parameter	At the Cam parameter, you configure the on-/off-times for the cam of the yearly timer.
	Output Q	Q is set when the configured cam is actuated.

Timing diagram

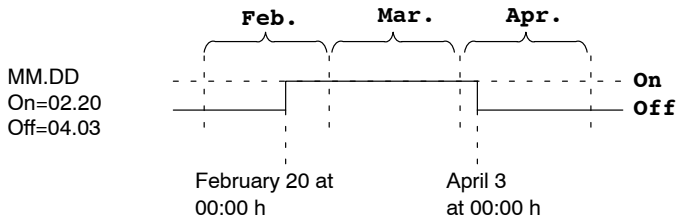

Functional description

The yearly timer sets the output at a specific on-time, and resets it at a specific off-time. The off-date identifies the day on which the output is reset again. The first value identifies the month, the second the day. For “MM” you can select a placeholder (**), so that the on- and off-time is set for a specific day each month.

Sample configuration

The output of a LOGO! is to be set annually on March 1, reset on April 4, set again on July 7, and reset again on November 19. You need to configure two yearly timers with corresponding on-times. The outputs are then logically linked by means of an OR block

B1	+
	MM-DD
On	=03-01
Off	=04-04

On-time March 1
Off-time April 4

B2	+
	MM-DD
On	=07-07
Off	=11-19

In addition:
On-time July 7
Off-time November 19

Result

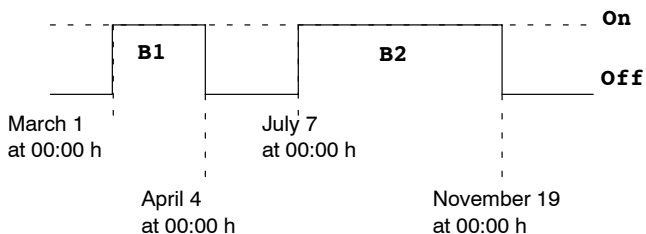

Further examples

```
B11      +
          **_DD
On =**_01
Off=**_02
```

On-time is the first,
and off-time the second day each month.

```
B12      +
          **_DD
On =**_10
Off=**_20
```

Each month, from the 10th through
to the 20th

```
B13      +
          **_DD
On =**_25
Off=**_05
```

In the next month,
from the 25th through the 5th

4.4.13 Up/down counter

Short description

An input pulse increments or decrements an internal value, depending on the parameter setting. The output is set or reset when a configured threshold is reached. The direction of count can be changed with a signal at input Dir.

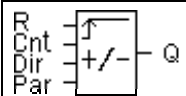
Symbol in LOGO!	Wiring	Description
	Input R	A signal at input R resets the internal count value to zero.
	Input Cnt	<p>The function counts the 0 to 1 transitions at input Cnt. 1 to 0 transitions are not counted.</p> <p>Use</p> <ul style="list-style-type: none"> • inputs I5/I6 for high-speed counting (only LOGO! 12/24 RC/RCo and LOGO! 24/24o): max. 2 kHz. • any other input or circuit component for counting low frequency signals (typ. 4 Hz).
	Input Dir	<p>You set the direction of count at input Dir:</p> <p>Dir = 0: Up count Dir = 1: Down count</p>

Symbol in LOGO!	Wiring	Description
	Parameter	On: On threshold Range of values: 0...999999 Off: Off threshold Range of values: 0...999999 Retentivity for internal counter value Cnt: / = No retentivity R = The status is retentive.
	Output Q	Q is set or reset, depending on the current value at Cnt and the set thresholds.

Timing diagram

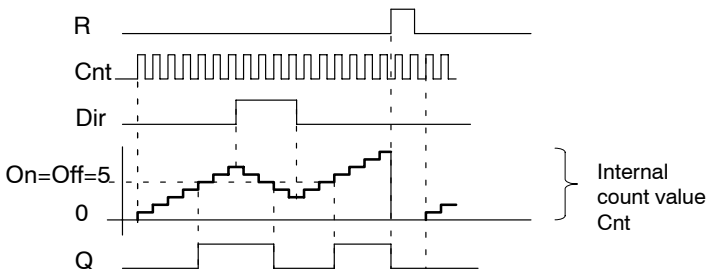

Functional description

The internal counter increments (Dir = 0) or decrements (Dir = 1) by one count with every positive edge at input Cnt.

You can use input R to reset the internal count value to '000000'. As long as R = 1, the output is also lo and the pulses at input Cnt are not counted.

If retentivity is not set, output Q and the expired time are reset after a power failure.

Q is set or reset depending on the current value at Cnt and the set thresholds. See the calculation rule below.

Calculation rule

- If the On threshold \geq Off threshold, then:
Q = 1, if Cnt \geq On
Q = 0, if Cnt < Off.
- If the On threshold < Off threshold, then Q = 1,
if On \leq Cnt < Off.

Default on/off parameters

The default limits for the on and/or off parameters can be derived from another, already programmed function. You can use the actual values of the following functions:

- Analog comparator (actual value Ax – Ay, see Chapter 4.4.18)
- Analog threshold trigger (actual value Ax, see Chapter 4.4.16)
- Analog amplifier (actual value Ax, see Chapter 4.4.20)
- Analog multiplexer (actual value AQ, see Chapter 4.4.26)
- Analog ramp (actual value AQ, see Chapter 4.4.27)
- PI controller (actual value AQ, see Chapter 4.4.28)
and
- Up/down counter (actual value Cnt).

Select the required function by means of the block number. For information on parameter defaults, refer to Chapter 4.4.1.

Note

The system scans the counter limit value cyclically.

Thus, if the pulse frequency at the fast inputs I5/I6 is faster than the cycle time, the special function might not switch until after the specified limit value is exceeded.

Example: Up to 100 pulses per cycle can be counted; 900 pulses have been counted so far. On = 950; Off = 10000. The output is set in the next cycle, after the value has reached 1000. (The output would not be set at all if the value Off = 980.)

View in programming mode (example):

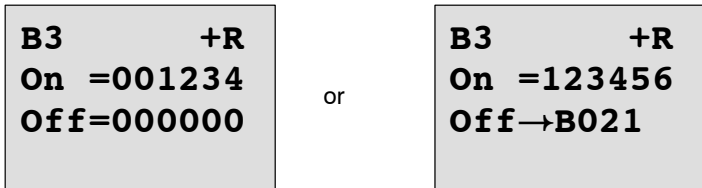

If the referenced block (B6, in the example) returns a value that lies out of the valid range, the value is rounded to the next valid value.

The view in parameter assignment mode (example):

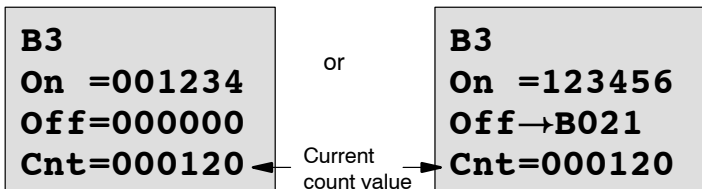

4.4.14 Hours counter

Short description

A configured time is triggered with a signal at the monitoring input. The output is set when this time has expired.

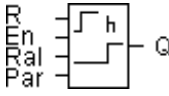
Symbol in LOGO!	Wiring	Description
	Input R	A positive edge (0 to 1 transition) at input R resets output Q and sets a configured value MI at the counter for the duration of the time-to-go (MN).
	Input En	En is the monitoring input. LOGO! scans the on-time of this input.
	Input Ral	<p>A positive edge at input Ral (Reset all) resets both the hours counter (OT) and the output, and sets the configured value MI at the counter to for the duration of the time-to-go (MN). That is,</p> <ul style="list-style-type: none"> • output Q = 0, • measured operating time OT = 0 and • the time-to-go of the maintenance interval MN = MI.

Symbol in LOGO!	Wiring	Description
	Parameter	<p>MI: Maintenance interval to be preset in hour units Range of values: 0000...9999 h</p> <p>OT: The accumulated total operating time; you can specify an offset Range of values: 00000...99999 h</p> <p>Q→0:</p> <ul style="list-style-type: none"> • When "R" is selected: Q = 1, if MN = 0; Q = 0, if R = 1 or Ral = 1 • When "R+En" is selected: Q = 1, if MN = 0; Q = 0, if R = 1 or Ral = 1 or En = 0.
	Output Q	<p>The output is set when the time-to-go MN = 0 (see timing diagram).</p> <p>The output is reset:</p> <ul style="list-style-type: none"> • When "Q→0:R+En", if R = 1 or Ral = 1 or En = 0 • When "Q→0:R", if R = 1 or Ral = 1.

MI = Configured time interval

MN= Time-to-go

OT= Total time expired since the last hi signal at input Ral

These values are always retentive!

Timing diagram

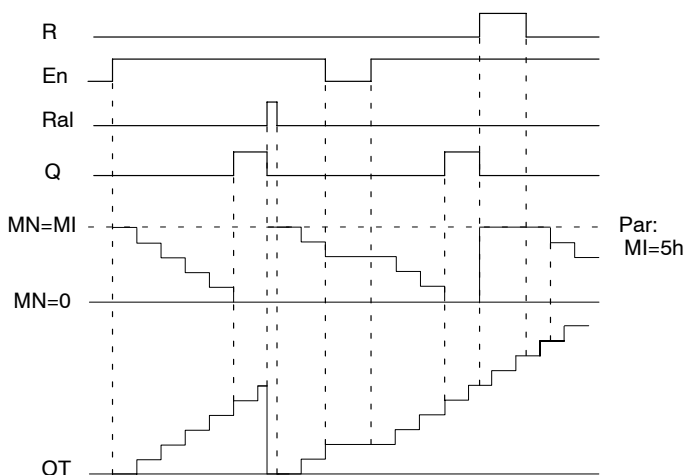

MI = Configured time interval

MN = Time-to-go

OT = Total time expired since the last hi signal at input Ral

Functional description

The hours counter monitors input En. When En = 1, LOGO! computes the time expired and the time-to-go MN. LOGO! shows these times in parameter assignment mode. Output Q is set when the time-to-go MN = 0.

A signal at reset input R resets output Q and sets the pre-set value of MI at the counter for the duration of MN. The hours counter OT is not affected.

With a signal at the reset input Ral, you reset output Q and set the preset value of MI at the counter for the duration of MN. The hours counter OT is reset to zero.

Depending on your configuration of parameter Q, the output is either reset with a signal at input R or Ral ("Q→0:R"), or when a reset signal is set hi, or the En signal is set lo ("Q→0:R+En").

Viewing the MI, MN and OT values

- LOGO! Basic with display unit: You can open the parameter assignment mode when the system is in RUN to view the actual values of MI, MN and OT.
- LOGO! Basic without display unit: In LOGO!Soft Comfort, you can use the Online Test to read these values (for further information, see Chapter 7).

Limit value of OT

The value of the operating hours in OT are retained when you reset the hours counter with a signal at input R. The hours counter OT continues the count as long as $En = 1$, irrespective of the status at the reset input R.

The counter limit of OT is 99999 h.

The hours counter stops when it reaches this value.

In programming mode, you can set the initial value of OT.

The counter starts operation at any value other than zero.

MN is automatically calculated at the START, based on the MI and OT values

(Example: MI = 100, OT = 130, the result is MN = 70).

Preset of the Par parameter

View in programming mode:

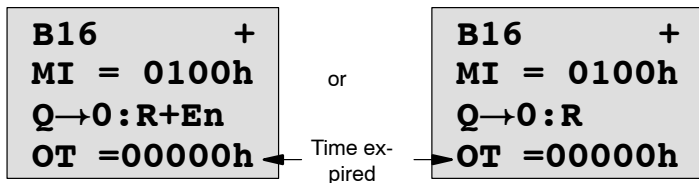

MI is the configurable time interval. Its permissible range of values lies between 0 and 9999 hours.

View in parameter assignment mode:

B16	
MI = 0100h	← Time interval
MN = 0017h	← Time-to-go
OT =00083h	← Total operating hours

4.4.15 Threshold trigger

Short description

The output is set and reset with two configurable threshold triggers.

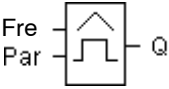
Symbol in LOGO!	Wiring	Description
 <p>The symbol shows a square box with two input lines on the left labeled 'Fre' and 'Par', and one output line on the right labeled 'Q'. Inside the box, there is a diagram of a square wave pulse with a triangle above it, representing a threshold trigger.</p>	Input Fre	<p>The function counts the 0 to 1 transitions at input Fre. 1 to 0 transitions are not counted.</p> <p>Use</p> <ul style="list-style-type: none"> inputs I5/I6 for high-speed counting (only LOGO! 12/24 RC/RCo and LOGO! 24/24o): max. 2 kHz. any other input or circuit component for counting low frequency signals (typ. 4 Hz).
	Parameter	<p>On: On threshold Range of values: 0000...9999</p> <p>Off: Off threshold Range of values: 0000...9999</p> <p>G_T: Time interval or gate time during which the input pulses are measured. Range of values: 00:05 s...99:99 s</p>
	Output Q	Q is set and reset at the thresholds.

Timing diagram

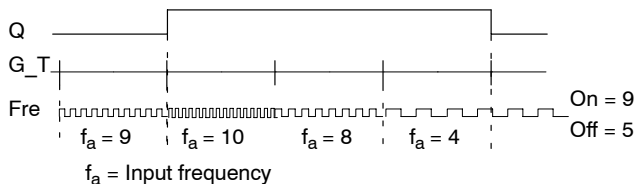

Functional description

The threshold trigger measures the signals at input Fre. The pulses are recorded across a configurable time G_T. Output Q is set and reset in accordance with the set thresholds. See the calculation rule below.

Calculation rule

- If the On threshold \geq Off threshold, then:
 - Q = 1, if $f_a > \text{On}$
 - Q = 0, if $f_a \leq \text{Off}$.
- If the On threshold < Off threshold, then Q = 1 if $\text{On} \leq f_a < \text{Off}$.

Preset of the Par parameter

Note

The system scans the counter limit value once per interval G_T.

View in programming mode (example):

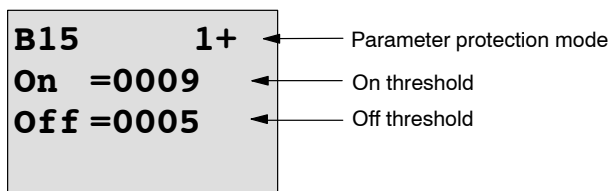

Press ►

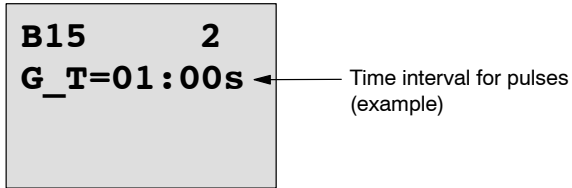
**Note**

The “seconds” timebase is here set as permanent default.

When you preset a time G_T of 1 s, LOGO! returns the current frequency in parameter f_a in Hz.

View in parameter assignment mode (example):

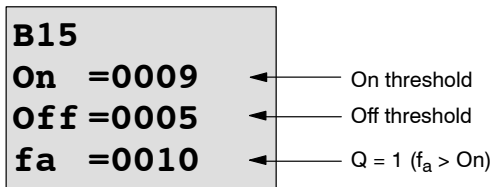
**Note**

f_a always represents the total pulses measured per time unit G_T.

4.4.16 Analog threshold trigger

Short description

The output is set and reset at two configurable thresholds.

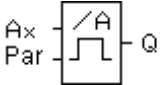
Symbol in LOGO!	Wiring	Description
	Input Ax	<p>You apply the analog signal to be analyzed at input Ax.</p> <p>Use the analog inputs AI1...AI8 (*), the analog flags AM1...AM6, the block number of a function with analog output, or the analog outputs AQ1 and AQ2.</p>
	Parameter	<p>A: Gain Range of values: ± 10.00</p> <p>B: Zero offset Range of values: $\pm 10,000$</p> <p>On: On threshold Range of values: $\pm 20,000$</p> <p>Off: Off threshold Range of values: $\pm 20,000$</p> <p>p: Number of decimals Range of values: 0, 1, 2, 3</p>
	Output Q	Q is set or reset by the threshold triggers.

* AI1...AI8: 0...10 V corresponds with 0...1000 (internal value).

Gain and offset parameters

Please note the information on gain and offset parameters in Chapter 4.3.6.

Parameter p (number of decimals)

Does not apply to the display of On, Off and Ax values in a message text.

Does not apply to the comparison of On and Off values!
(The compare function ignores the decimal point.)

Timing diagram

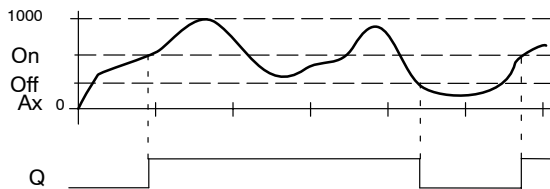

Functional description

The function fetches the analog signal at input A_x .

A_x is multiplied by the value of the A (gain) parameter, and the value at parameter B (offset) is added to product, i.e.
 $(A_x \cdot \text{gain}) + \text{offset} = \text{actual value of } A_x$.

Output Q is set or reset, depending on the set thresholds.
See the calculation rule below.

Calculation rule

- If the On threshold \geq Off threshold, then:
 $Q = 1$, if the actual value $A_x > \text{On}$
 $Q = 0$, if the actual value $A_x \leq \text{Off}$.
- If the On threshold $<$ Off threshold, then $Q = 1$ if
 $\text{On} \leq \text{actual value } A_x < \text{Off}$.

Preset of the Par parameter

The gain and offset parameters are used to adapt the sensors to the relevant application.

View in programming mode (example):

B3	1+	←	Parameter protection mode
On	=+04000	←	On threshold
Off	=+02000	←	Off threshold

Press ►

B3	2		
A	=01.00	←	Gain
B	=+00000	←	Offset
p	=2	←	Decimals in the message text

View in parameter assignment mode (example):

B3			
On	=+04000	←	On threshold
Off	=+02000	←	Off threshold
Ax	=+05000	←	Q = 1 (Ax > On)

View in the message text (example):

+050.00	←	Ax, when p = 2 Q = 1 (Ax > On)
----------------	---	-----------------------------------

4.4.17 Analog differential trigger

Short description

The output is set and reset depending on a configurable threshold and a differential value.

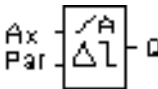
Symbol in LOGO!	Wiring	Description
	Input Ax	<p>You apply the analog signal to be analyzed at input Ax.</p> <p>Use the analog inputs AI1...AI8 (*), the analog flags AM1...AM6, the block number of a function with analog output, or the analog outputs AQ1 and AQ2.</p>
	Parameter	<p>A: Gain Range of values: $\pm 10,00$</p> <p>B: Zero offset Range of values: $\pm 10,000$</p> <p>On: On/Off threshold Range of values: $\pm 20,000$</p> <p>Δ: Differential value for calculating the off parameter Range of values: $\pm 20,000$</p> <p>p: Number of decimals Range of values: 0, 1, 2, 3</p>
	Output Q	Q is set or reset, depending on the threshold and difference values.

* AI1...AI8: 0...10 V corresponds with 0...1000 (internal value).

Gain and offset parameters

Please note the information on gain and offset parameters in Chapter 4.3.6.

Parameter p (number of decimals)

Does not apply to the display of On, Off and Ax values in a message text.

Timing diagram A: Function with negative difference Δ

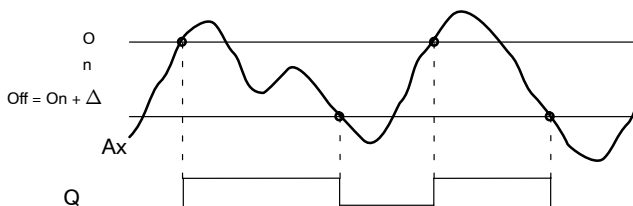

Timing diagram B: Function with positive difference Δ

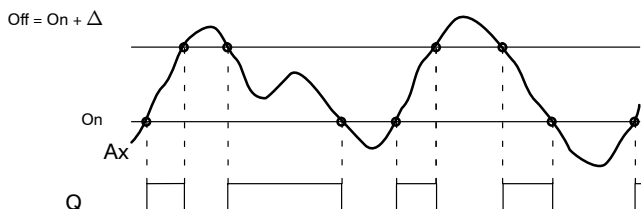

Functional description

The function fetches the analog signal at input A_x .

A_x is multiplied by the value of the A (gain) parameter, and the value at parameter B (offset) is added to product, i.e. $(A_x \cdot \text{gain}) + \text{offset} = \text{actual value of } A_x$.

Output Q is set or reset, depending on the set (On) threshold and difference value (Δ). The function automatically calculates the Off parameter: $Off = On + \Delta$, whereby Δ may be positive or negative. See the calculation rule below.

Calculation rule

- When you set a negative differential value Δ , the On threshold \geq Off threshold, and:
 $Q = 1$, if the actual value $Ax > \text{On}$
 $Q = 0$, if the actual value $Ax \leq \text{Off}$.
 See the timing diagram A.
- When you set a positive differential value Δ , the On threshold $<$ the Off threshold, and $Q = 1$, if:
 $\text{On} \leq \text{actual value } Ax < \text{Off}$.
 See the timing diagram B.

Preset of the Par parameter

The gain and offset parameters are used to adapt the sensors to the relevant application.

View in programming mode (example):

B3	1+	← Parameter protection mode
On	=+04000	← On/off threshold
Δ	=-02000	← Differential value for the on/off threshold

Press ►

B3	2	
A	=01.00	← Gain
B	=+00000	← Offset
p	=2	← Decimals in the message text

View in parameter assignment mode (example):

B3		
On	=+04000	← On threshold
Δ	=-02000	← Differential value for the off threshold
Ax	=+05000	← $Q = 1$ ($Ax > \text{On}$)

Press ▼

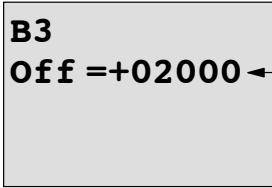

Off threshold

4.4.18 Analog comparator

Short description

The output is set and reset depending on the difference $A_x - A_y$ and on two configurable thresholds.

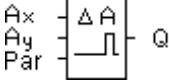
Symbol in LOGO!	Wiring	Description
	Inputs A_x and A_y	<p>You apply the analog signals the difference of which you want to analyze at the inputs A_x and A_y.</p> <p>Use the analog inputs $A11...A18$ (*), the analog flags $AM1...AM6$, the block number of a function with analog output, or the analog outputs $AQ1$ and $AQ2$.</p>
	Parameter	<p>A: Gain Range of values: ± 10.00</p> <p>B: Zero offset Range of values: $\pm 10,000$</p> <p>On: On threshold Range of values: $\pm 20,000$</p> <p>Off: Off threshold Range of values: $\pm 20,000$</p> <p>p: Number of decimals Range of values: 0, 1, 2, 3</p>
	Output Q	Q is set or reset, depending on the difference $A_x - A_y$ and the set thresholds..

* $A11...A18$: 0...10 V corresponds with 0...1000 (internal value).

Gain and offset parameters

For more information on the gain and offset parameters, refer to Chapter 4.3.6.

Parameter p (number of decimals)

Does not apply to Ax, Ay, On, Off and Δ values displayed in a message text.

Does not apply to the comparison of on and off values!
(The compare function ignores the decimal point.)

Timing diagram

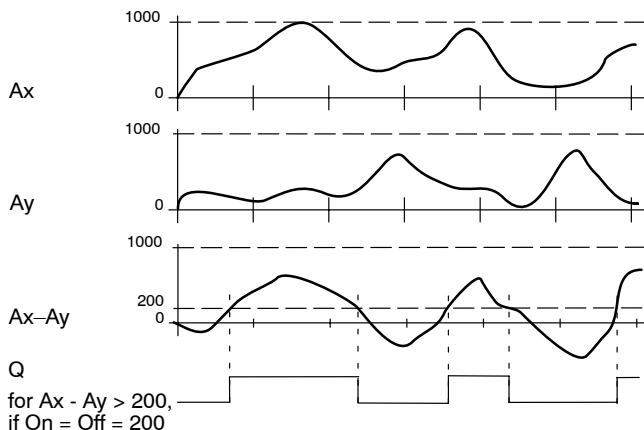

Functional description

The function fetches the analog values from the inputs Ax and Ay.

Ax and Ay are each multiplied by the value of the A (gain) parameter, and the value at parameter B (offset) is then added to the relevant product, i.e.

$$(Ax \cdot \text{gain}) + \text{offset} = \text{actual value } Ax$$

$$(Ay \cdot \text{gain}) + \text{offset} = \text{actual value } Ay$$

The function forms the difference (" Δ ") between the actual values $Ax - Ay$.

Output Q is set or reset, depending on difference of the actual values $Ax - Ay$ and the set thresholds. See the calculation rule below.

Calculation rule

- If the On threshold \geq Off threshold, then:
 $Q = 1$, if:
 $(\text{actual value } A_x - \text{actual value } A_y) > \text{On}$
 $Q = 0$, if:
 $(\text{actual value } A_x - \text{actual value } A_y) \leq \text{Off}$.
- If the On threshold $<$ Off threshold, then $Q = 1$, if:
 $\text{On} \leq (\text{actual value } A_x - \text{actual value } A_y) < \text{Off}$.

Preset of the Par parameter

The gain and offset parameters are used to adapt the sensors to the relevant application.

View in programming mode:

B3	1+	← Parameter protection mode
On	=+00000	← On threshold
Off	=+00000	← Off threshold

Press ►

B3	2	
A	=00.00	← Gain
B	=+00000	← Offset
p	=0	← Decimals in the message text

Example

In a heating control system, the supply T_v and return line temperatures T_r are to be compared, for example with a sensor at AI2.

A control signal is to be triggered (for example "heater On") when the difference between the supply and return line temperatures is greater than 15° . The control signal is reset when the difference is less than 5°C .

The process variable of the temperature is to be shown in parameter assignment mode.

The thermocouples available have the the following technical data: -30 to $+70$ °C, 0 to 10 VDC.

Application	Internal mapping
-30 to $+70$ °C = 0 to 10 V DC	0 to 1000
0 °C	300 → Offset = -30
Range of values: -30 to $+70$ °C = 100	1000 → Gain = $100/1000 = 0.1$
On threshold = 15 °C	Threshold = 15
Off threshold = 5 °C	Threshold = 5

See also Chapter 4.3.6.

Configuration (example):

B3	1+	← Protection mode
On	=+00015	← On threshold
Off	=+00005	← Off threshold

Press ►

B3	2	
A	=00.10	← Gain
B	=-00030	← Offset
p	=0	← Decimals in the message text (if used)

View in parameter assignment mode (example):

B3	1	
On	=+00015	← On threshold
Off	=+00005	← Off threshold

Press ▼

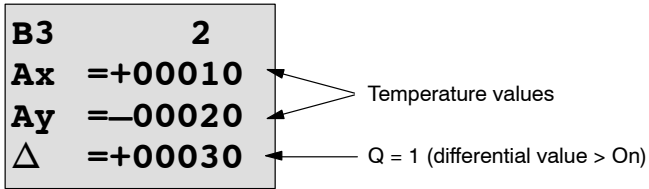

View in the message text (example):

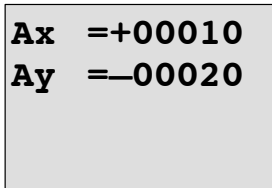

Reducing the input response of the analog comparator

You can selectively delay the output of an analog comparator by means of the “On-delay” and “Off-delay” special functions. With on-delay, output Q is only set if the pulse width of the triggering signal at input Trg (=analog comparator output) is longer than the on-delay time.

Using this method, you will obtain a virtual hysteresis and reduce the input response to short signals.

Function block diagram

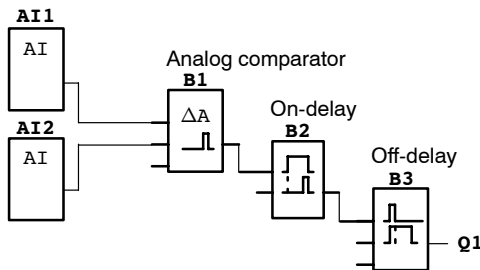

4.4.19 Analog value monitoring

Short description

This special function saves the process variable of an analog input to memory, and sets the output when the output variable exceeds or drops below this stored value plus a configurable offset.

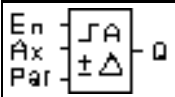
Symbol in LOGO!	Wiring	Description
	Input En	A positive edge (0 to 1 transition) at input En saves the analog value at input Ax ("Aen") to memory and starts monitoring of the analog range $Aen \pm \Delta$.
	Input Ax	You apply the analog signal to be monitored at input Ax. Use the analog inputs AI1...AI8 (*), the analog flags AM1...AM6, the block number of a function with analog output, or the analog outputs AQ1 and AQ2.
	Parameter	A: Gain Range of values: ± 10.00 B: Zero offset Range of values: $\pm 10,000$ Δ : Difference value for the Aen on/off threshold Range of values: $\pm 20,000$ p: Number of decimals Range of values: 0, 1, 2, 3
	Output Q	Q is set/reset, depending on the stored analog value and the offset.

* AI1...AI8: 0...10 V corresponds with 0...1000 (internal value).

Gain and offset parameters

For more information on gain and offset parameters, refer to Chapter 4.3.6.

Parameter p (number of decimals)

Applies only to the Aen, Ax and Δ values displayed in a message text.

Timing diagram

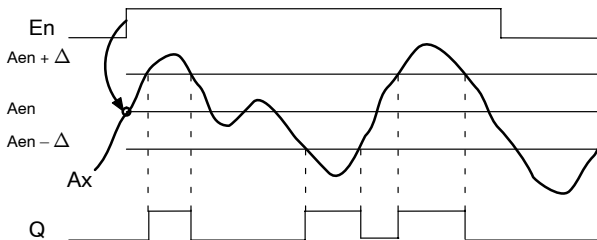

Functional description

A 0 to 1 transition at input En saves the value of the signal at the analog input Ax. This saved process variable is referred to as "Aen".

Both the analog actual values Ax and Aen are multiplied by the value at parameter A (gain), and parameter B (offset) is then added to the product, i.e.

$(Ax \cdot \text{gain}) + \text{offset} = \text{Actual value Aen}$, when input En changes from 0 to 1, or

$(Ax \cdot \text{gain}) + \text{offset} = \text{Actual value Ax}$.

Output Q is set when the signal at input En = 1 and if the actual value at input Ax is out of range of $Aen \pm \Delta$.

Output Q is reset, when the actual value at input Ax lies within the range of $Aen \pm \Delta$, or when the signal at input En changes to 0.

Preset of the Par parameter

The gain and offset parameters are used to adapt the used sensors to the respective application.

View in programming mode:

B3	1+	←	Parameter protection mode
Δ	=±00000	←	Differential value for the on/off threshold

Press ►

B3	2		
A	=00.00	←	Gain
B	=+00000	←	Offset
P	=0	←	Decimals in the message text

View in parameter assignment mode (example):

B3			
Δ	=±00010		
Aen	=-00020		
Ax	=+00005	←	Q = 1 (Ax is out of the range of Aen ± Δ)

4.4.20 Analog amplifier

Short description

This special function amplifies the value of an analog input and outputs the result at an analog output.

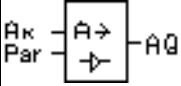
Symbol in LOGO!	Wiring	Description
	Input Ax	<p>You apply the analog signal to be amplified at input Ax.</p> <p>Use the analog inputs AI1...AI8 (*), the analog flags AM1...AM6, the block number of a function with analog output, or the analog outputs AQ1 and AQ2.</p>
	Parameter	<p>A: Gain Range of values: ± 10.00</p> <p>B: Zero offset Range of values: $\pm 10,000$</p> <p>p: Number of decimals Range of values: 0, 1, 2, 3</p>
	Output AQ	<p>This special function has an analog output! This output can only be connected with the analog input of a function, an analog flag or an analog output connector (AQ1, AQ2).</p> <p>Range of values for AQ: $-32768...+32767$</p>

* AI1...AI8: 0...10 V corresponds with 0...1000 (internal value).

Gain and offset parameters

Please note the information on gain and offset parameters in Chapter 4.3.6.

Parameter p (number of decimals)

Applies only to the AQ value in a message text.

Functional description

The function fetches the analog signal of input Ax.

This value is multiplied by the value of the A (gain) parameter, and parameter B (offset) is then added to the product, i.e. $(Ax \cdot \text{gain}) + \text{offset} = \text{actual value Ax}$.

The actual value Ax is output at AQ.

Analog output

If you interconnect this special function with a real analog output, note that the analog output can only process values between 0 and 1000. To do this, you may need to connect an additional amplifier between the analog output of the special function and the real analog output. Using this amplifier, you standardize the output range of the special function to a value range of 0 to 1000.

Scaling an analog input value

You can influence the analog input value of a potentiometer by interconnecting an analog input with an analog amplifier and an analog flag.

- Scale the analog value at the analog amplifier for further use.
- Connect, for example, the time base for parameter T of a time function (e.g. On-/Off-delay, Chapter 4.4.3) or the on and/or off limit specification of an up/down counter (Chapter 4.4.13) to the scaled analog value.

For more information with programming examples refer to the online help for LOGO!Soft Comfort.

Preset of the Par parameter

The gain and offset parameters are used to adapt the sensors to the relevant application.

View in programming mode (example):

B3	+	
A	=02.50	← Gain
B	=-00300	← Offset
P	=0	← Decimals in the message text

View in parameter assignment mode (example):

B3	
A	=02.50
B	=-00300
AQ	=-00250

4.4.21 Latching relay

Short description

Input S sets output Q, input R resets output Q again.

Symbol in LOGO!	Wiring	Description
	Input S	You set output Q with a signal at input S.
	Input R	You reset output Q with a signal at input R. If S and R = 1, the output is reset.
	Parameter	Retentivity: / = No retentivity R = The status is retentive.
	Output Q	Q is set with a signal at input S, and reset with a signal at input R.

Timing diagram

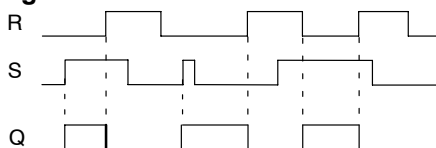

Switching response

A latching relay represents a simple binary element. The output value depends on the status at the inputs and on the previous output status. The following table shows the logic once again:

S _n	R _n	Q	Comment
0	0	x	The status is retentive
0	1	0	Reset
1	0	1	Set
1	1	0	Reset (takes priority over Set)

When retentivity is enabled, the current status of the output signal is retained after a power failure.

4.4.22 Pulse relay

Short description

A short pulse at the input sets and resets the output.

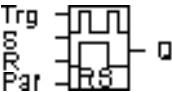
Symbol in LOGO!	Wiring	Description
	Input Trg	You set and reset output Q with a signal at input Trg (Trigger).
	Input S	You set output Q with a signal at input S.
	Input R	You reset output Q with a signal at input R.
	Parameter	Selection: RS (R input priority) or SR (S input priority) Retentivity: / = No retentivity R = The status is retentive.
	Output Q	Q is set with a signal at Trg, and reset with the next signal at Trg, if S and R = 0.

Timing diagram

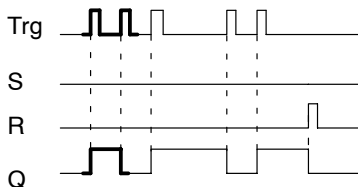

The bold printed section of the timing diagram is also shown in the symbol for the pulse relay.

Functional description

Output Q changes its status, i.e. the output is set or reset, with each 0 to 1 transition at input Trg and if the inputs S and R = 0.

The signal at input Trg does not influence the special function when S or R = 1.

You set the pulse relay with a signal at input S, i.e. the output is set hi.

You reset the pulse relay with a signal at input R, i.e. the output is set lo.

Status diagram

Par	Q _{n-1}	S	R	Trg	Q _n
*	0	0	0	0	0
*	0	0	0	0 → 1	1**
*	0	0	1	0	0
*	0	0	1	0 → 1	0
*	0	1	0	0	1
*	0	1	0	0 → 1	1
RS	0	1	1	0	0
RS	0	1	1	0 → 1	0
SR	0	1	1	0	1
SR	0	1	1	0 → 1	1
*	1	0	0	0	1
*	1	0	0	0 → 1	0**
*	1	0	1	0	0
*	1	0	1	0 → 1	0
*	1	1	0	0	1
*	1	1	0	0 → 1	1
RS	1	1	1	0	0
RS	1	1	1	0 → 1	0

Par	Q_{n-1}	S	R	Trg	Q_n
SR	1	1	1	0	1
SR	1	1	1	0 → 1	1

*: RS or SR

**: Triggering signal is effective, because S and R = 0.

Depending on your configuration, either input R takes priority over input S (i.e. input S is not effective when R = 1), or vice versa (i.e. input R is not effective when S = 1).

After a power failure, the pulse relay and output Q are reset if you have not enabled retentivity.

View in programming mode:

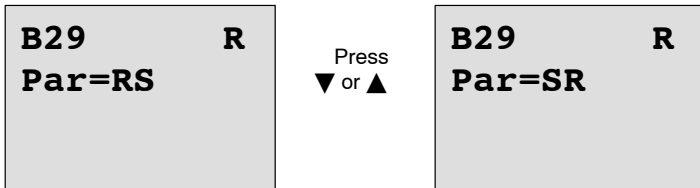

This special function is not available in parameter assignment mode.

Note

If Trg = 0 and Par = RS, the special function “Pulse relay” corresponds with the special function “Latching relay” (see Chapter 4.4.21).

4.4.23 Message texts

Short description

View of a configured message text in RUN mode.

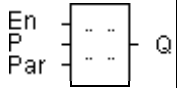
Symbol in LOGO!	Wiring	Description
 <p>The symbol is a rectangular box with three input lines on the left labeled 'En', 'P', and 'Par', and one output line on the right labeled 'Q'. Inside the box, there are two pairs of dots representing the internal logic.</p>	Input En	A 0 to 1 transition at input En (Enable) starts the output of the message text.
	Input P	P: Priority of the message text Range of values: 0...30 Quit: Acknowledgment of the message text.
	Parameter	Text: Input of the message text Par: Parameter or actual value of another, already programmed function (see "Visible parameters or process variables") Time: Display of the continuously updated time-of-day Date: Display of the continuously updated date EnTime: Display of the time of the 0 to 1 transition of the signal at input En EnDate: Display of the date of the 0 to 1 transition of the signal at input En
	Output Q	Q remains set as long as the message text is set.

Restriction

A maximum of 10 message text functions are available.

Functional description

With the 0 to 1 transition of the signal at input En and when the system is in RUN, the message text you have configured (process variable, text, time-of-day, date) is output to the display.

Acknowledgment disabled (Quit = Off):

The message text is hidden when the status of the signal at input En changes from 1 to 0.

Acknowledgment enabled (Quit = On):

When the status of the signal at input En changes from 1 to 0, the message text is output until it is acknowledged with **OK**. When En = 1, you cannot acknowledge the message text.

When multiple message text functions are triggered with En=1, the message text that has the highest priority is shown (0 = lowest, 30 = highest). This also means, that a newly activated message text is shown only if its priority is higher than that of previously activated message texts.

After a message text is disabled or acknowledged, the function automatically shows the previously active message text that takes the highest priority.

You can change the view and the message texts by pressing the keys ▲ and ▼ .

Example

This is how two message texts could be shown:

Display field of LOGO! in RUN mode

```
Motor 5
STOP AT
10:12
!!Action!!
```

← Example: Message text with priority 30

▼ Key ▲

```
Motor 2
3000
hours
MAINTENANCE!
```

← Example: Message text with priority 10

▼ Press ▲

```
Mo 09:00
2003-01-27
```

Date and current time-of-day (only for versions with real-time clock).

Input P configuration

To configure the priority and the acknowledgment (programming mode):

```
B33 +
Priority
00
Quit=Off
```

← "+" means: The parameters and actual values in an active message text can be edited

← Priority

← Status of the acknowledgment

1. Increase the priority to 1: Cursor on '0' + ▲
2. Change to 'Quit': Press ►
3. Enable 'Quit': Press ▲ or ▼

LOGO! shows:

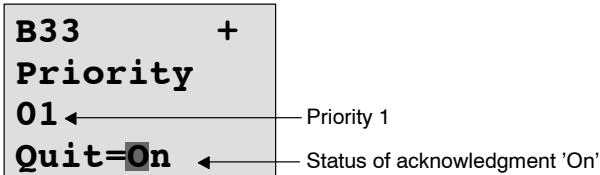

4. Confirm the entries with **OK**

Visible parameters or process variables

The following parameters or process variables can be displayed in a message text:

Special function	Parameter or process variable visible in a message text
Times	
On-delay	T, T _a
Off-delay	T, T _a
On-/Off-delay	T _a , T _H , T _L
Retentive on-delay	T, T _a
Wiping relay (pulse output)	T, T _a
Edge triggered wiping relay	T _a , T _H , T _L
Asynchronous pulse generator	T _a , T _H , T _L
Random generator	T _H , T _L
Stairway lighting switch	T _a , T, T _I , T _{IL}
Multiple function switch	T _a , T, T _L , T _I , T _{IL}
Weekly timer	3*on/off/day
Yearly timer	On, Off
Counter	
Up/down counter	Cnt, On, Off
Hours counter	MI, Q, OT

Special function	Parameter or process variable visible in a message text
Threshold trigger	f _a , On, Off, G_T
Analog	
Analog threshold trigger	On, Off, A, B, Ax
Analog differential trigger	On, Δ, A, B, Ax, Off
Analog comparator	On, Off, A, B, Ax, Ay, ΔA
Analog value monitoring	Δ, A, B, Ax, Aen
Analog amplifier	A, B, Ax
Analog multiplexer	V1, V2, V3, V4, AQ
Analog ramp	L1, L2, MaxL, StSp, Rate, A, B, AQ
PI controller	SP, Mq, KC, TI, Min, Max, A, B, PV, AQ
Miscellaneous	
Latching relay	–
Pulse relay	–
Message texts	–
Softkey	On/Off
Shift register	–

Changing parameters in the active message text

You can allow editing of parameter and process variables in an active message text by entering a “+” in the first line. To prevent changes, enter a “–” sign.

When the message text is active, press **ESC** to select the editing mode.

Note

You must keep the **ESC** key pressed for at least one second.

Press ◀ and ▶ to select the relevant line (you can only select lines that contain parameters). Press **OK** to change the parameter. Use the keys ◀, ▶, ▲ and ▼.

Confirm your changes with **OK**. You can now edit further parameters in the message text (if any exist). Press **ESC** to exit editing mode.

Key input simulation in the active message text

You can enable the four cursor keys C ▲, C ▶, C ▼ and C ◀ in an active message text by pressing **ESC** plus the relevant cursor key.

Preset of the Par parameter

To configure the message text (programming mode):



Parameter assignment
screen form for Par

Press ▶ to select a line for the message text.

Press ▲ and ▼ to select the relevant type of message text (Text, Par, Time...). Confirm with **OK**.

Further entries are required when “Text” or “Par” are selected:

Press ▲ and ▼ to select the letter to be displayed in the text. To move the cursor from one position to the other, press ◀ and ▶.

The list of available characters is here the same as for the circuit program name. The character set is found in Chapter 3.7.4.

Press **OK** to confirm your changes, and press **ESC** to exit the editing mode.

To output a parameter (e.g. a process variable or function value) as message text, select the relevant line with ▶ and then press ▼:

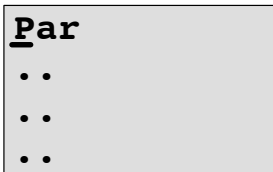

Press **OK** to open the editing mode:

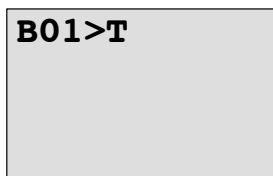

Press ◀ and ▶ to select the blocks to be displayed and the corresponding parameters.

Press ▲ and ▼ to select the block or parameter you want to view.

Select the parameter by pressing **OK**.

Press **ESC** to exit the parameter assignment mode and to apply your changes.

4.4.24 Softkey

Short description

This special function has the effect of a mechanical push-button or switch.

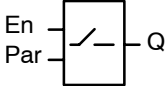
Symbol in LOGO!	Wiring	Description
	Input En	Output Q is set with a 0 to 1 transition of the signal at input En (Enable), and if 'Switch=On' was confirmed in parameter assignment mode.
	Parameter	<p><u>Programming mode:</u> Selecting the function for pushbutton action for the duration of one cycle, or for switching action.</p> <p>Start: On or off state, initialized at the first start of the program if retentivity is disabled.</p> <p>Retentivity: / = No retentivity R = The status is retentive.</p> <p><u>Parameter assignment mode (RUN mode):</u> Switch: Switches the momentary pushbutton or switch on or off.</p>
	Output Q	Switches on if En=1 and Switch=On was confirmed with OK .

Factory setting

The default setting at 'Par' is 'Momentary pushbutton' action.

Timing diagram

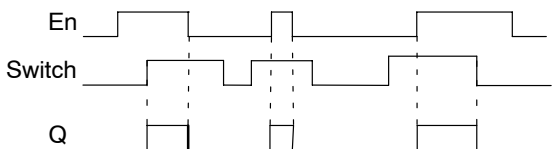

Functional description

In parameter assignment mode, the output is set with a signal at input En, if the "Switch" parameter is set to 'On' and confirmed with **OK**. Whether the function was configured for pushbutton or switching action is of no concern here.

The output is reset to '0' in the following three cases:

- After a 0 to 1 transition at input En.
- When the function was configured for momentary pushbutton action, and one cycle has expired since it was switched on.
- When the position 'Off' was selected at the 'Switch' parameter and confirmed with **OK** in parameter assignment mode.

If retentivity is not set, output Q is initialized after a power failure according to your configuration at the "Start" parameter.

Preset of the Par parameter

View in programming mode (example):

1. Select the 'Softkey' function.
2. Select input En and confirm with **OK**. The cursor is now positioned below 'Par'.
3. Change to the input mode of 'Par': Confirm with **OK** (the cursor is now positioned to 'On')

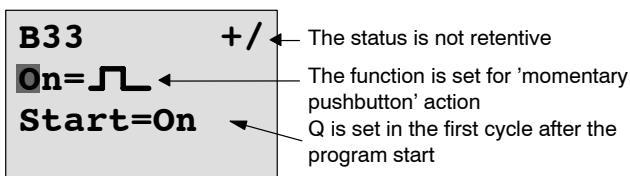

To change 'Par' to 'Switch' action and the initialization status after the program start:

4. To select 'Momentary pushbutton' or 'Switch' action:
Press ▲ or ▼

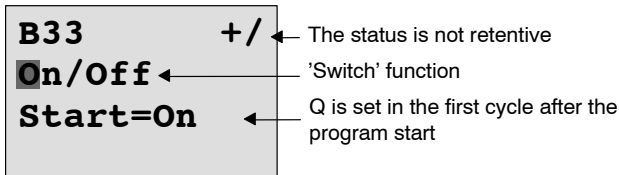

5. To change to the start state: Press ◀ or ▶
6. To change the start state: Press ▲ or ▼

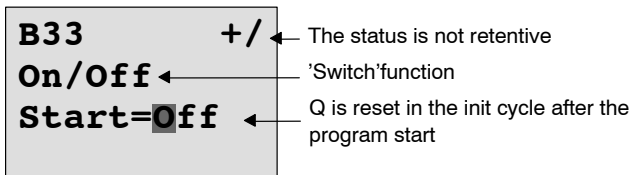

7. Confirm your entries with **OK**

View in parameter assignment mode (example):

Here, you can set or reset the 'Switch' parameter (On/Off).
When in RUN, LOGO! shows the following display:

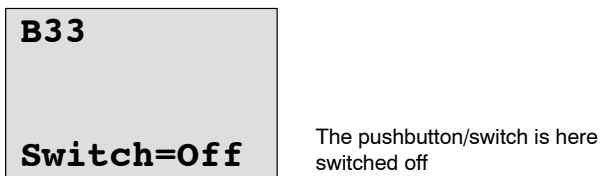

Let us assume you want to set 'Switch' (On).

1. Change to the editing mode: Confirm with **OK**
(the cursor is now positioned on 'Off')
2. To change from 'Off' to 'On': Press ▲ or ▼
3. Confirm your entries with Press **OK**

B33

Switch=On

The momentary pushbutton/switch
is here switched on

4.4.25 Shift register

Short description

You can use the shift register function to read the value of an input and to shift its bits left or right. The output value corresponds with the configured shift register bit. The shifting direction can be changed at a special input.

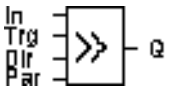
Symbol in LOGO!	Wiring	Description
	Input In	Input read at the start of the function.
	Input Trg	A positive edge (0 to 1 transition) at input Trg (Trigger) starts the special function. 1 to 0 transitions are irrelevant.
	Input Dir	The signal at input Dir determines the shifting direction for the shift register bits S1...S8 an: Dir = 0: Shift up (S1 >> S8) Dir = 1: Shift down (S8 >> S1)
	Parameter	Shift register bit that determines the value at output Q. Possible settings: S1 ... S8 Retentivity: / = No retentivity R = The status is retentive.
	Output Q	The output value corresponds with the configured shift register bit.

Preset of the Par parameter

View in programming mode:

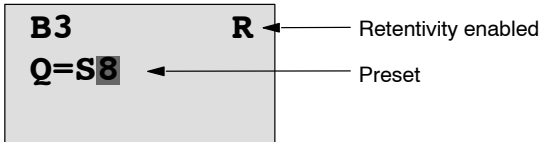

Press ▼

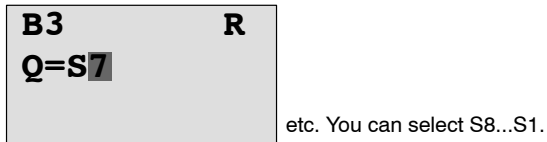

This special function is not available in parameter assignment mode.

4.4.26 Analog Multiplexer

Short description

This special function outputs one of four predefined analog values or 0 at the analog output.

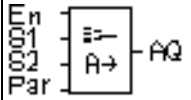
Symbol in LOGO!	Wiring	Description
	Input En	A change in status from 0 to 1 at input En (Enable) switches a parameterized analog value to the output AQ, depending on the value of S1 and S2.
	Inputs S1 and S2	S1 and S2 (selectors) for selecting the analog value to be issued. <ul style="list-style-type: none"> • S1 = 0 and S2 = 0: Value 1 is issued • S1 = 0 and S2 = 1: Value 2 is issued • S1 = 1 and S2 = 0: Value 3 is issued • S1 = 1 and S2 = 1: Value 4 is issued

Symbol in LOGO!	Wiring	Description
	Parameter	V1...V4: Analog values that will be issued. Range of values: -32768...+32767 p: Number of decimals Range of values: 0, 1, 2, 3
	Output AQ	This special function has an analog output. This output can only be connected with the analog input of a function, an analog flag or an analog output connector (AQ1, AQ2). Range of values for AQ: -32768...+32767

Parameters V1...V4

The analog values for the parameters V1...V4 can be derived from another, already programmed function. You can use the actual values of the following functions:

- Analog comparator (actual value $A_x - A_y$, see Chapter 4.4.18)
- Analog threshold trigger (actual value A_x , see Chapter 4.4.16)
- Analog amplifier (actual value A_x , see Chapter 4.4.20)
- Analog multiplexer (actual value AQ)
- Analog ramp (actual value AQ, see Chapter 4.4.27)
- PI controller (actual value AQ, see Chapter 4.4.28) and
- Up/down counter (actual value Cnt, see Chapter 4.4.13).

Select the required function by means of the block number. For information on parameter defaults, refer to Chapter 4.4.1.

Parameter p (number of decimals)

Applies only to the values displayed in a message text.

Timing diagram

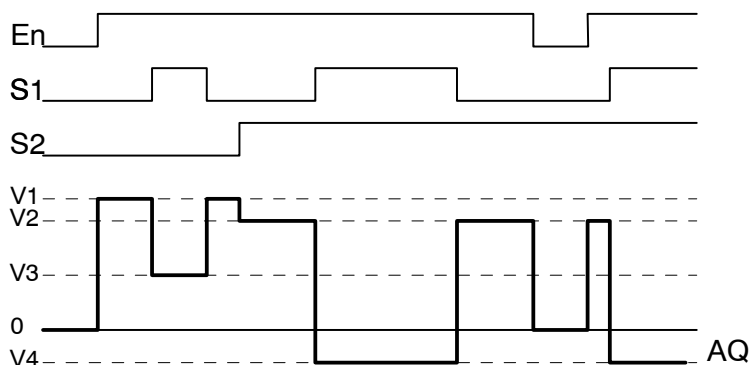

Functional description

If input En is set, then the function issues one of 4 possible analog values V1 to V4 at the output AQ, depending on the value of S1 and S2.

If the input En is not set, then the function issues the analog value 0 at output AQ.

Analog output

If you interconnect this special function with a real analog output, note that the analog output can only process values between 0 and 1000. To do this, you may need to connect an additional amplifier between the analog output of the special function and the real analog output. Using this amplifier, you standardize the output range of the special function to a value range of 0 to 1000.

Preset of the Par parameter

View in programming mode (example):

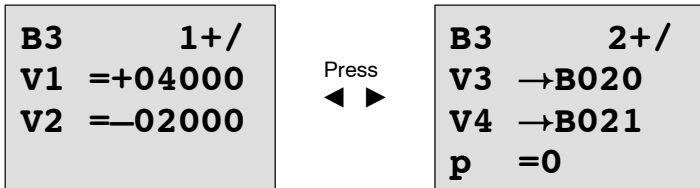

View in parameter assignment mode:

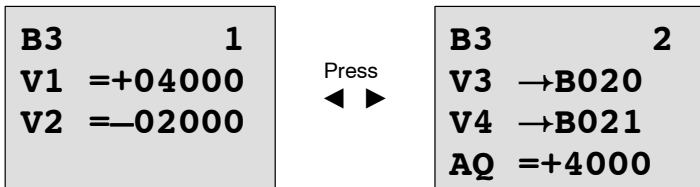

4.4.27 Analog Ramp

Short description

At the analog output, this special function starts up one of two levels or offset. Here you can set how quickly the level should be reached. The analog value is calculated in two steps. The first step allows you to carry out convenient parameterization. The second step standardizes the result of the first one.

Unless otherwise stated, the description refers to the first step.

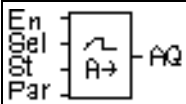
Symbol in LOGO!	Wiring	Description
 <p>The symbol shows a rectangular box with four input terminals on the left labeled 'En', 'Sel', 'St', and 'Par'. Inside the box, there is a small square containing a sawtooth wave symbol and the text 'A→'. A single output terminal on the right is labeled 'AQ#'. The 'En' input is connected to the top of the box, 'Sel' to the middle, and 'St' to the bottom. 'Par' is connected to the bottom of the box.</p>	Input En	<p>A change in the status from 0 to 1 at input En (Enable) launches the start-up of a parameterized analog value at output AQ#.</p> <p>A change in the status from 1 to 0 immediately issues Offset (B) at output AQ# and 0 at output AQ.</p>
	Input Sel	<ul style="list-style-type: none"> • Sel = 0: Level 1 is started • Sel = 1: Level 2 is started
	Input St	<p>A change in the status from 0 to 1 at input En (Enable) launches the start-up of the value Offset (B) at output AQ# and with this 0 at output AQ.</p>

	Parameter	<p>Level 1 and Level 2: Levels to be reached Range of values for each level: -10,000 to +20,000</p> <p>MaxL: Maximum value that must not be exceeded under any circumstances. Range of values: -10,000 to +20,000</p> <p>StSp: Start/Stop offset, value that is issued for 100ms in addition to parameter Offset (B) after launching the function and before reaching the Offset value (prompted by input St). This parameter is intended for controlling motors. Range of values: 0 to +20,000</p> <p>Rate: Acceleration with which level 1, level 2 or Offset is reached. Steps/seconds are issued. Range of values: 1 to 10,000</p> <p>A: Gain Range of values: 0 to 10.00</p> <p>B: Offset Range of values: ±10,000</p> <p>p: Number of decimals Range of values: 0, 1, 2, 3</p>
--	-----------	------------------------------------------------------------------------------------------------------------------------------------------------------------------------------------------------------------------------------------------------------------------------------------------------------------------------------------------------------------------------------------------------------------------------------------------------------------------------------------------------------------------------------------------------------------------------------------------------------------------------------------------------------------------------------------------------------------------------------------------------------------------------------------------------------------------------------------------------------------------------------------------

Symbol in LOGO!	Wiring	Description
	Output AQ#	AQ# is the analog output of the first step. The system shows you the value of AQ# in simulation mode, for example. A reference uses this value. Range of values for AQ: -32767 ...+32767
	Output AQ	AQ is the standardized value of AQ# and the analog output of the second step. The value of AQ is passed on to downstream blocks. Range of values for AQ: 0 to +32767

Parameters L1, L2

The analog values for the parameters L1 and L2 can be derived from another, already programmed function. You can use the actual values of the following functions:

- Analog comparator (actual value $A_x - A_y$, see Chapter 4.4.18)
- Analog threshold trigger (actual value A_x , see Chapter 4.4.16)
- Analog amplifier (actual value A_x , see Chapter 4.4.20)
- Analog multiplexer (actual value AQ, see Chapter 4.4.26)
- Analog ramp (actual value AQ)
- PI controller (actual value AQ, see Chapter 4.4.28) and
- Up/down counter (actual value Cnt, see Chapter 4.4.13).

Select the required function by means of the block number. For information on parameter defaults, refer to Chapter 4.4.1.

Parameter p (number of decimals)

Applies only to the AQ, L1, L2, MaxL, StSp and Rate values displayed in a message text.

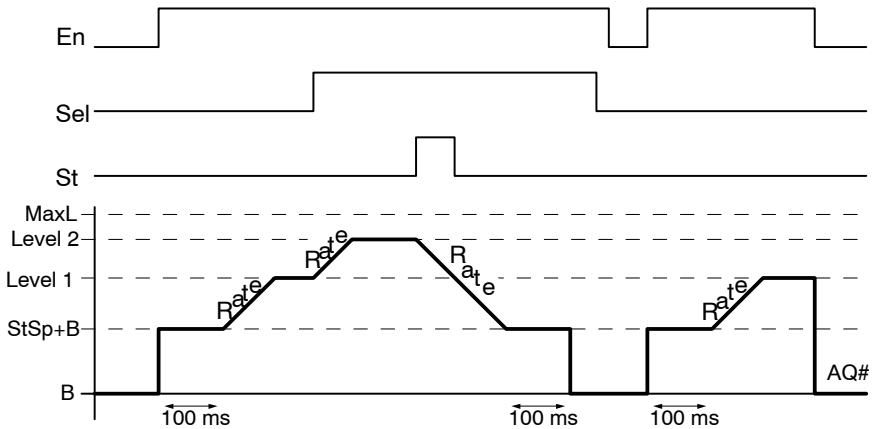
Timing diagram for AQ#**Functional description of step 1**

If the input En is set, then the function issues the value $\text{StSp} + B$ at output AQ# for the first 100 ms.

Then, depending on the connection of Sel, the function runs from value $\text{StSp} + B$ to either level 1 or level 2 at the acceleration set in Rate.

If the input St is set, the function runs to the value StSp + B at the acceleration set in Rate. Then the function issues the value StSp + B at output AQ# for 100 ms. Finally Offset (B) is issued at output AQ#.

If the input St is set, the function can only be restarted once the inputs St and En have been reset.

If input Sel has been changed, depending on the connection of Sel, the function runs from Level 1 to Level 2 or the other way round.

If the input En is reset, the function immediately issues Offset (B) at output AQ#.

The analog value at the output is recalculated every 100 ms.

Functional description of step 2

Using parameters A (Gain) and B (Offset), AQ is standardized according to the following formula:

$$AQ = (AQ\# - \text{Offset}) / \text{Gain}$$

Note

For further information on analog value processing please refer to the Online Help for LOGO!Soft Comfort.

Preset of the Par parameter

View in programming mode (example):

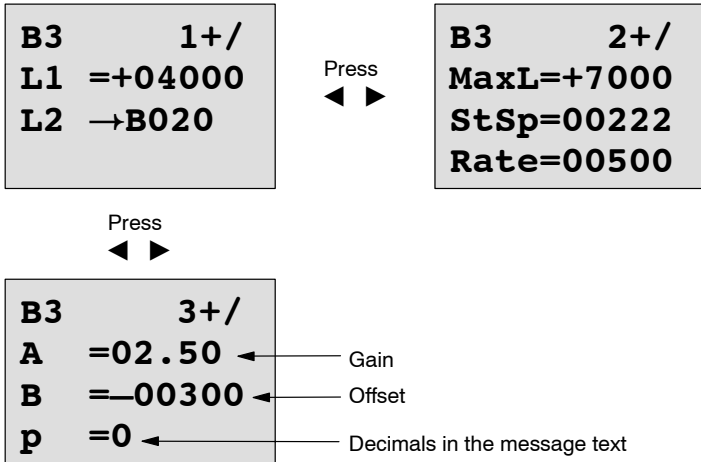

View in parameter assignment mode:

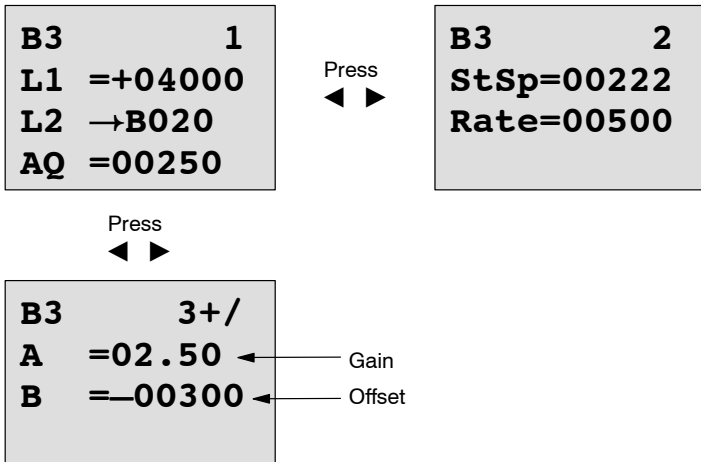

4.4.28 PI controller

Short description

Proportional-action and integral-action controllers. You can use both types of controller individually or combined.

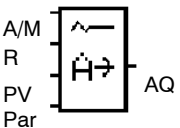
Symbol in LOGO!	Wiring	Description
 <p>The symbol is a rectangular box with four input terminals on the left labeled A/M, R, PV, and Par. Inside the box, there is a schematic of a PI controller: a resistor symbol (zigzag line) in series with an integrator symbol (a circle with a dot inside). An output terminal on the right is labeled AQ.</p>	Input A/M	Set the mode of the controller: 1: automatic mode 0: manual mode
	Input R	Use the input R to reset the output AQ. As long as this input is set, the input A/M is disabled. Output AQ is set to 0.
	Input PV	Analog value: process value, influences the output

Symbol in LOGO!	Wiring	Description
	Parameter	<p>SP: Set-value assignment Range of values: -10,000 to +20,000</p> <p>KC: Gain Range of values: 00.00 to 99.99</p> <p>TI: Integral time Range of values: 00:01 to 99:59 m</p> <p>Dir: Action direction of the controller Range of values: + or -</p> <p>Mq: Value from AQ with manual mode Range of values: 0 to 1000</p> <p>Min: Minimum value for PV Range of values: -10,000 to +20,000</p> <p>Max: Maximum value for PV Range of values: -10,000 to +20,000</p> <p>A: Gain Range of values: ± 10.00</p> <p>B: Offset Range of values: $\pm 10,000$</p> <p>p: Number of decimals Range of values: 0, 1, 2, 3</p>

Symbol in LOGO!	Wiring	Description
	Output AQ	This special function has an analog output (= manipulated variable). This output can only be connected with the analog input of a function, an analog flag or an analog output connector (AQ1, AQ2). Range of values for AQ: 0...1000

Parameters SP, Mq

The analog values for the parameters SP and Mq can be derived from another, already programmed function. You can use the actual values of the following functions:

- Analog comparator (actual value Ax – Ay, see Chapter 4.4.18)
- Analog threshold trigger (actual value Ax, see Chapter 4.4.16)
- Analog amplifier (actual value Ax, see Chapter 4.4.20)
- Analog multiplexer (actual value AQ, see Chapter 4.4.26)
- Analog ramp (actual value AQ, see Chapter 4.4.27)
- PI controller (actual value AQ)
and
- Up/down counter (actual value Cnt, see Chapter 4.4.13).

Select the required function by means of the block number. For information on parameter defaults, refer to Chapter 4.4.1.

Parameters KC, TI

Please note:

- If parameter KC has value 0, the “P” function (proportional control) will not be executed.
- If parameter TI has value 99:59 m, the “I” function (integral-action control) will not be executed.

Parameter p (number of decimals)

Applies only to the PV, SP, Min and Max values displayed in a message text.

Timing diagram

The nature, manner and speed with which the AQ changes depend on the parameters KC and TI. Thus, the course of AQ in the diagram is merely an example. A control action is continuous; therefore the diagram portrays just an extract.

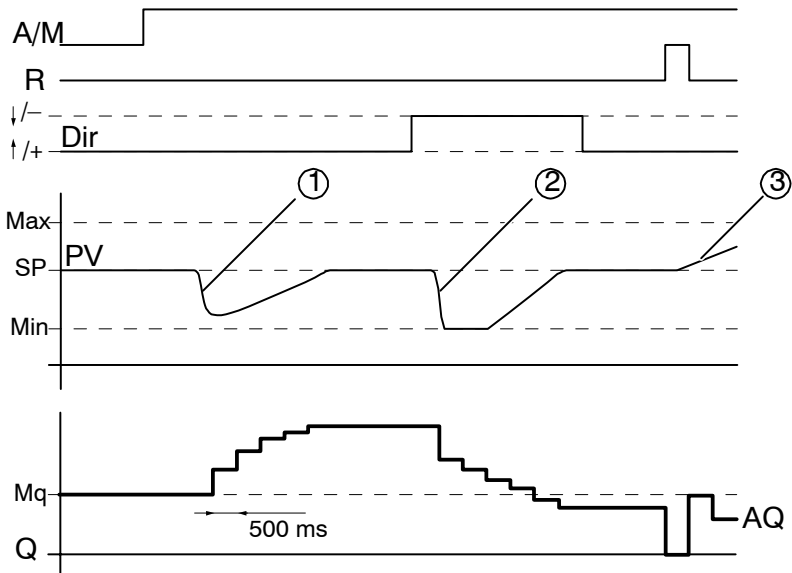

1. A disturbance causes the PV to drop, as Dir is positioned upwards, AQ increases until PV corresponds again to SP.
2. A disturbance causes the PV to drop, as Dir is positioned downwards, AQ decreases until PV corresponds again to SP.

It is not possible to change the direction (Dir) at runtime of the function. The change is shown here for illustrative purposes only.

3. As AQ is set to 0 by means of the input R, PV changes. This is based on the fact that PV increases, which on account of Dir = upwards causes AQ to drop.

Functional description

If the input A/M is set to 0, then the special function issues output AQ with the value that you set with parameter Mq.

If the input A/M is set to 1, then automatic mode commences. As an integral sum the value Mq is adopted, the controller function begins the calculations.

Note

For further information on the controller basics please refer to the Online Help for LOGO!Soft Comfort.

The updated value PV is used to calculate in the formulas:

$$\text{Updated value PV} = (\text{PV} \cdot \text{gain}) + \text{offset}$$

- If the updated value PV = SP, then the special function does not change the value of AQ.
- Dir = upwards (+) (timing diagram numbers 1. and 3.)
 - If the updated value PV > SP, then the special function reduces the value of AQ.
 - If the updated value PV < SP, then the special function increases the value of AQ.
- Dir = downwards (–) (timing diagram number 2.)
 - If the updated value PV > SP, then the special function increases the value of AQ.
 - If the updated value PV < SP, then the special function reduces the value of AQ.

With a disturbance, AQ continues to increase / decrease until the updated value PV again corresponds to SP. The speed with which AQ changes depends on the parameters KC and TI.

If the input PV exceeds the parameter Max, then the updated value PV is set to the value of Max. If the PV falls short of the parameter Min, then the updated value PV is set to the value of Min.

If the input R is set to 1, then the AQ output is reset. As long as R is set, the input A/M is disabled.

Sampling time

The sampling time is fixed at 500 ms.

Parameter sets

For more information and application examples with application-related parameter sets for KC, TI and Dir refer to the online help for LOGO!Soft Comfort.

Preset of the Par parameter

View in programming mode (example):

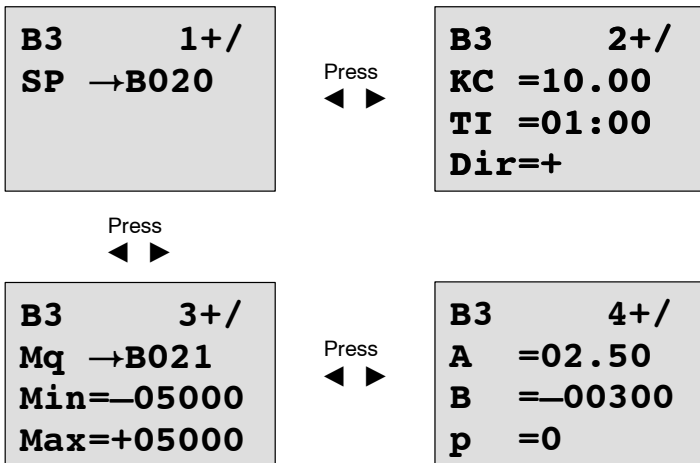

View in parameter assignment mode:

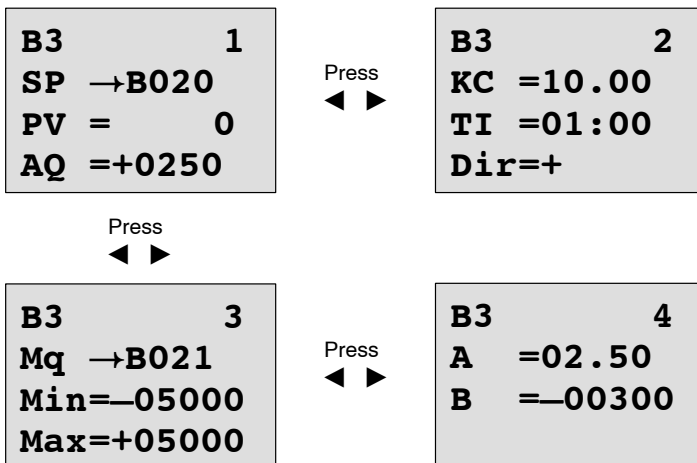

5 Configuring LOGO!

When speaking of 'parameter assignment', we refer to the configuration of the block parameters. You can set delay times for time functions, the switching times of the timers, the counter threshold value, the monitoring interval of an hours counter and the on and off thresholds of the trigger.

You can configure the parameters

- In programming mode
- In parameter assignment mode

In programming mode, the author of the circuit program also sets the parameters.

We have added the parameter assignment mode to allow the editing of parameters without having to modify the circuit program. This feature is available for the user to edit parameters, without having to change to programming mode, for example. The advantage: The circuit program remains protected, but can be adapted by the user to meet specific requirements.

Note

In parameter assignment mode, LOGO! continues execution of the circuit program.

5.1 Selecting parameter assignment mode

Press **ESC** to change from RUN to parameter assignment mode:

```
Mo 09:00
2005-01-27
```

... Press **ESC**

Note

The following applies to earlier device versions up to 0BA2:

- You open parameter assignment mode by pressing **ESC+OK**.

LOGO! changes to parameter assignment mode and opens the parameter assignment menu:

```
>Stop
Set Param
Set..
Prg Name
```

Description of the four menu items of the parameter assignment menu

- **Stop**

You select this command to stop your circuit program and thus change to the main menu of programming mode. To do so:

1. To move the '>' cursor to '**Stop**': Press ▲ or ▼
2. To confirm 'Stop': Press **OK**

```

Stop Prg
>No
Yes

```

3. To move the '>' cursor to '**Yes**': Press ▲ or ▼
4. To confirm 'Yes': Press **OK**

LOGO! shows the main menu of the programming mode:

```

>Program..
Card..
Setup..
Start

```

- **Set Param**

For information on the various parameters, refer to the Chapters 5.1.1 to 5.1.3.

- **Set..**

For information on the various settings, refer to Chapter 5.2.

- **Prg Name**

This menu command only allows you to **read** the name of your circuit program. It is not possible to modify this name in parameter assignment mode (see Chapter 3.7.4).

5.1.1 Parameters

Note

In the following discourse on parameters, we presume that the respective default parameter protection mode ("+") has been maintained. This is a prerequisite for viewing and editing parameters in the parameter assignment mode! See Chapter 4.3.5 and the example on Page 91.

Parameters are, for example:

- The delay times of a timer relay.
- The switching times (cams) of a timer switch.
- Counter thresholds
- The monitoring time for hour counters
- The trigger thresholds.

Each one of the parameters is identified by its block number (Bx) and the shortname of the parameter. Examples:

- T: ...is a configurable time.
 - MI: ...is a configurable time interval.
-

Note

LOGO!Soft Comfort also allows you to assign names to blocks (for more information, refer to Chapter 7).

5.1.2 Selecting the parameters

To select a parameter:

1. On the parameter assignment menu, select 'Set Param': Press ▼ or ▲

```

Stop
>Set Param
Set..
Prg Name
    
```

2. Confirm with **OK**.
LOGO! shows the first parameter. If no parameter can be set, you can press ESC to return to the parameter assignment menu.

```

B9      1
T =60:00s
Ta =06:00s
    
```

Block number
 Display number for functions with several displays
 The value set at parameter T (Time)
 The current time in LOGO!

```

No Param
Press ESC
    
```

No parameters for editing:
 Press ESC to return to the parameter menu

3. Now, select the desired parameter: Press ▲ or ▼.
4. Select the parameter you want to edit, and press **OK**.

5.1.3 Modifying parameters

You first select the parameter you want to edit (see Chapter 5.1.2).

You change the value of the parameter in the same way as you did in programming mode:

1. Move the cursor to the point at which you want to make the change: Press ◀ or ▶
2. To change this value: Press ▲ or ▼
3. To apply the value: **OK**

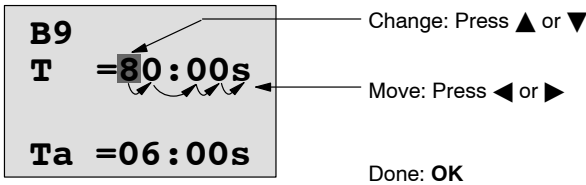

Note

When changing the time parameters when the system is in RUN, you can also change the timebase (s = seconds, m = minutes, h = hours). This does not apply if the time parameter represents the result of another function (for an example, see Chapter 4.4.1). In this case you can neither change the value nor the timebase.

The current time is reset to zero when you change the timebase.

Current value of a time T

View of a time T in parameter assignment mode:

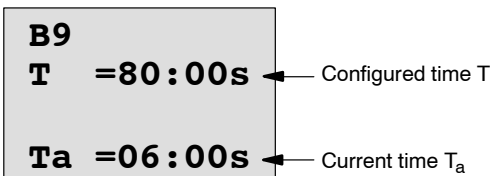

You can change the configured time T.

Current timer value

View of a timer cam in parameter assignment mode:

```

B1      1
D=M-W-F—
On =09:00
Off=10:00
    
```

You can change the on/off times and the day.

Current value of a counter

View of a counter parameter in parameter assignment mode:

<pre> B3 On =001234 Off=000000 Cnt=000120 </pre>	or	<pre> B3 On =123456 Off→B021 Cnt=000120 </pre>
	← Current count value →	

You can change the on/off threshold. This does not apply if the on or off threshold represents the result of another function (in the example, this is B21, see Chapter 4.4.13).

Current value of an hour counter

View of an hour counter parameter in parameter assignment mode:

<pre> B16 MI = 0100h MN = 0017h OT =00083h </pre>	←	Time interval
	←	Time-to-go
	←	Total operating hours

You can edit the configured time interval MI.

Current value of a threshold trigger

View of the parameter of a threshold trigger in parameter assignment mode:

B15	
On =0009	← On threshold
Off =0005	← Off threshold
fa =0010	← Process variable

You can change the on/off threshold.

5.2 Setting the default values for LOGO!

You can set the following default values for LOGO!:

Clock settings

You can set the default values for time-of-day and date, summertime/wintertime conversion and synchronization

- in parameter assignment mode by means of the set menu (“Clock” menu item)
- in programming mode by means of the setup menu (“Clock” menu item).

Time-of-day and date see Chapter 5.2.1.

Summertime/wintertime conversion see Chapter 3.7.13.

Synchronization see Chapter 3.7.14.

Contrast settings

You can set the default value for the display contrast

- in parameter assignment mode by means of the set menu (“Contrast” menu item)
- in programming mode by means of the setup menu (“Contrast” menu item).

See Chapter 5.2.2.

Start screen settings

You can select the default setting for the start screen

- in parameter assignment mode by means of the set menu (“StartScreen” menu item).

See Chapter 5.2.3.

5.2.1 Setting the time-of-day and date (LOGO! ... C)

You can set the TOD and the date

- in parameter assignment mode by means of the set menu (“Clock” menu item)
- in programming mode by means of the setup menu (“Clock” menu item).

To set the TOD and the date in parameter assignment mode:

1. Select parameter assignment mode (see Chapter 5.1.)
2. On the parameter assignment menu, select 'Set..': Press ▼ or ▲

```
Stop
Set Param
>Set..
Prg Name
```

3. Confirm 'Set..': Press **OK**
4. Move the '>' cursor to 'Clock': Press ▲ or ▼
5. Confirm 'Clock': Press **OK**
6. Move the '>' cursor to 'Set Clock': Press ▲ or ▼
7. Apply 'Set Clock': Press **OK**

Note

The 'Set Clock' command is only executed if your LOGO! is equipped with a real-time clock (LOGO!..C). You set the real-time clock of LOGO! by means of the 'Set Clock' command.

LOGO! shows the following display.

```
Set Clock
Mo 15:30
YYYY-MM-DD
2005-01-27
```

The cursor is positioned on the weekday.

8. Select the day of the week: Press ▲ or ▼
9. Move the cursor to the next position: Press ◀ or ▶
10. To change the value: Press ▲ or ▼
11. To set the correct TOD, repeat steps 9. and 10.
12. To set the correct date, repeat steps 9. and 10.
13. To confirm your entries: Press **OK**

To set the TOD and the date in programming mode:

If you want to set the TOD and the date in programming mode, select '**Setup**' in the main menu, then menus '**Clock**' and '**Set Clock**'. You can now set the weekday and the time as described earlier (as of step 8.).

5.2.2 Setting the display contrast

You can set the default value for the display contrast

- in parameter assignment mode by means of the set menu ("Contrast" menu item)
- in programming mode by means of the setup menu ("Contrast" menu item).

To set the display contrast in parameter assignment mode:

1. Select parameter assignment mode (see Chapter 5.1.)
2. On the parameter assignment menu, select '**Set..**': Press **▼** or **▲**
3. Confirm '**Set..**': Press **OK**
4. Move the '>' cursor to '**Contrast**': Press **▲** or **▼**
5. Confirm '**Contrast**': Press **OK**

LOGO! shows the following display:

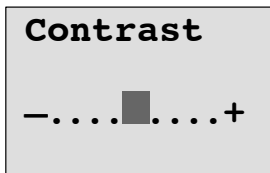

6. To change the display contrast: Press **◀** or **▶**
7. To confirm your entry: Press **OK**

To set the display contrast in programming mode:

If you want to set the display contrast in programming mode, select '**Setup**' in the main menu, then menu '**Contrast**'. You can now set the display contrast as described earlier (as of step 6.).

5.2.3 Setting the start screen

You can select the default setting for the start screen of LOGO! in RUN mode:

- in parameter assignment mode by means of the set menu ("StartScreen" menu item).

To select the start screen:

1. Select parameter assignment mode (see Chapter 5.1.)
2. On the parameter assignment menu, select '**Set..**': Press **▼** or **▲**
3. Confirm '**Set..**': Press **OK**
4. Move the '>' cursor to '**StartScreen**': Press **▲** or **▼**
5. Confirm '**StartScreen**': Press **OK**

LOGO! shows the following display:

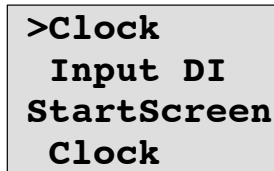

```
>Clock
  Input DI
  StartScreen
  Clock
```

The current setting of the start screen is shown in the bottom row. The default setting is 'Clock'.

You can choose between the display of the current time-of-day and date, or the values of the digital inputs:

6. Select the desired default setting: Press **▲** or **▼**.
7. To confirm your entry: Press **OK**

6 LOGO! program module (card)

LOGO! allows you to store only one circuit program in its memory. If you want to modify the circuit program or create a further one without deleting the first, you must archive it somewhere. One of the options is to use a program module/card.

The circuit program stored in LOGO! can be copied to a program module (card). You can then insert the program module/card in another LOGO! in order to copy the circuit program. using the program module (card), you can:

- Archive circuit programs
- Reproduce circuit programs
- Send circuit programs by mail
- Write and test your circuit program at the office, and then transfer it to a LOGO! in the switching cabinet.

LOGO! is supplied with a hood. The program module (card) is supplied separately.

Note

You do **not** need a module to backup the circuit program in your LOGO!.

The LOGO! circuit program is automatically stored in non-volatile memory when you exit the programming mode.

We shall now introduce the program module (Card) you can order for LOGO! The card can backup all data in the LOGO! circuit program memory.

The order number is found in the appendix.

Compatibility

... to current versions (0BA4 and 0BA5 devices):

Data written to the program module (card) in an 0BA4 version can be read in all 0BA4 and 0BA5 versions.

Data written to the program module (card) in an 0BA5 version can be read in all 0BA5 versions.

... to earlier versions (0BA0 to 0BA3 devices):

A program module (card) that contains data written in earlier versions (0BA0...0BA3 devices) cannot be used in LOGO! devices of the 0BA4 or 0BA5 generation. When the LOGO! system detects such an 'old' program module (card), the message "Unknown Card / Press ESC" is output to the display.

Vice versa, an 0BA4 or 0BA5 program module (card) cannot be used in LOGO! devices of the 0BA0...0BA3 family.

Upward compatibility of circuit programs

Circuit programs written for the previous versions 0BA0...0BA3 can only be applied in 0BA4 or 0BA5 units by means of LOGO!Soft Comfort.

6.1 Security function (CopyProtect)

We principally distinguish between program modules (card) with and without circuit program/copy protection.

Unprotected program module (card)

You can edit circuit programs without restrictions, and exchange data between the program module (Card) and the device.

Protected program module (card)

A circuit program is **protected** when it is transferred from a protected program module (card) to LOGO!.

To execute this circuit program in LOGO!, the protected program module (card) must remain inserted during RUN, i.e. the circuit program stored on the program module (card) cannot be copied to other LOGO! devices.

Over and above that, a protected circuit program is write-protected.

A circuit program **with password** protection is no longer protected after the correct password has been entered, i.e. you can then edit the program and remove the module.

Note

You need to assign a password when you create the circuit program for a protected module (card) to be able to edit it at a later time (see Chapter 3.7.5).

Correlation between the password and the protective function

Password	Protection	Editing	Copying	Deleting
-	-	Yes	Yes	Yes
Yes	-	Yes, with password	Yes	Yes, with password
-	Yes	No	No	Yes
Yes	Yes	Yes, with password	Yes, with password	Yes, with password

Assigning a security function

To assign a circuit program and copy protection function to the program module (card), open the programming mode and select "Card".

1. Switch LOGO! to programming mode (ESC / >Stop).
2. The main menu opens. To select the '**Card**' command:
Press ▲ or ▼
3. To apply 'Card': Press **OK**
4. Move the '>' cursor to '**CopyProtect**': Press ▲ or ▼
5. To apply 'CopyProtect': Press **OK**

LOGO! shows the following display:

```
>No
  Yes
CopyProtect :
  No
```

The current protection setting is shown in the bottom line. This function is disabled by default ("No": disabled).

Enabling the security function

To set the security function:

1. Move the '>' cursor to **'Yes'**: Press **▲** or **▼**
2. Confirm **'Yes'**: Press **OK**

LOGO! shows the following display:

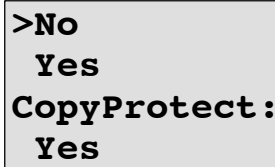

```
>No
  Yes
CopyProtect:
  Yes
```

Note

This only generates a circuit program and copy protection for the program module (card); the circuit program itself must be copied separately from LOGO! to the program module (card) (can also be done initially).

You can always change the “No” status (security function disabled) to “Yes” (security function enabled).

A status change from “Yes” (security function enabled) to “No” (security function disabled) is only possible if the program module (card) does not contain a circuit program.

6.2 Inserting and removing the program module (card)

When you remove a program module (card) with circuit program and copy protection attributes, note the following: The circuit program stored on the program module (card) can only be executed if the card remains inserted during system runtime.

After you have removed the program module (card), LOGO! outputs the message 'No Program'. A removal of the program module (card) during RUN will lead to impermissible operating states.

Always heed the following warning:



Warning

Do not touch the open slot of the program module (card) neither with your fingers, nor with a metallic or conductive object.

The program module (card) socket may be under voltage if the polarity is accidentally reversed at L1 and N.

The program module (card) may only be removed by qualified personnel.

Removing the program module (card)

To remove the program module (card):

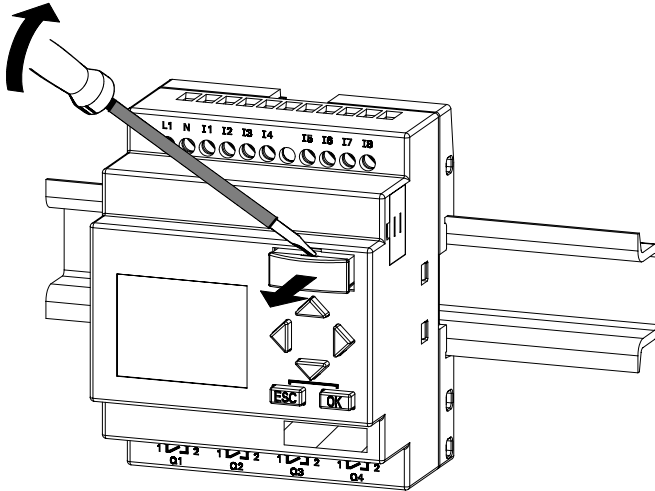

Carefully insert a screwdriver into the groove on the upper end of the program module (card) and lever the module partially out of the slot.

You can now remove the program module (card).

Inserting a program module (card)

The entry of the program module (card) slot is chamfered on its bottom right. The edge of the program module (card) is chamfered accordingly. This encoding prevents you from inserting the program module (card) the wrong way round. Insert the program module (card) into the slot and push it in until it engages.

6.3 Copying data from LOGO! to the program module (card)

To copy the circuit program to the program module (card):

1. Insert the program module (card) into the slot.
2. Switch LOGO! to programming mode (ESC / >Stop).

```
>Program..
Card..
Setup..
Start
```

LOGO! main menu

3. The main menu opens. To select the 'Card' command:
Press ▲ or ▼
4. Press **OK**. The transfer menu opens.

```
>[+]->Card
Card->[+]-
CopyProtect
```

[+]- = LOGO!

5. Move the '>' cursor to '**LOGO → Card**' (if required)
Press ▲ or ▼
6. Press **OK**.

LOGO! now copies the circuit program to the program module (card).

When LOGO! has finished copying, it automatically returns you to the main menu:

```
>Program..
Card..
Setup..
Start
```

The circuit program backup is now stored on your program module (card) and you can remove the card. **Do not forget** to replace the cap.

If power fails while LOGO! is copying the circuit program, repeat the process after Power On.

Note

The password X of a protected circuit program in LOGO! also applies to the copied program version on your program module (card).

6.4 Copying data from the program module (card) to LOGO!

You have a program module (card) that contains your circuit program. There are two ways to copy it to LOGO!:

- Automatically during the startup of LOGO! (POWER ON) or
- by means of the “Card” menu of LOGO!.

Note

If the program on the module/card is protected with the password X, the copied program in LOGO! is also protected with the same password.

Automatic copying during the startup of LOGO!

Proceed as follows:

1. Switch off the power supply to LOGO! (POWER OFF)
2. Remove the slot cover.
3. Insert the program module/card into the relevant slot.
4. Switch on the power supply to LOGO!

LOGO! copies the program from the program module/card to LOGO!. When LOGO! has finished copying, it opens the main menu:

```
>Program..
  Card..
  Setup..
  Start
```

Note

Before you switch LOGO! to RUN, you must ensure that the system you are controlling with LOGO! does not represent a source of hazard.

1. Move the '>' cursor to **'Start'**: Press ▲ or ▼
2. Press **OK**.

Copying by means of the “Card” menu

For information on the replacement of a program module (card), also note Chapter 6.2.

To copy a program from the program module (card) to LOGO!:

1. Insert the program module (card)
2. Switch LOGO! to programming mode (ESC / >Stop).

```

>Program..
  Card..
  Setup..
  Start
```

3. Move the '>' cursor to **'Card'**: Press ▲ or ▼
4. Press **OK**. The transfer menu opens.
5. Move the '>' cursor to **'Card → LOGO'**:
Press ▲ or ▼

```

[ ]+ →Card
>Card → [ ]+
CopyProtect
```

[]+ = LOGO!

6. Press **OK**.

LOGO! copies the circuit program from the program module (card) to LOGO!. When LOGO! has finished copying, it automatically returns to the main menu.

7 LOGO! Software

LOGO!Soft Comfort is available as a programming package for the PC. This software provides many features, for example:

- A graphic interface for offline creation of your circuit program by means of Ladder Diagram (contact chart / circuit diagram) or Function Block Diagram (function chart)
- Simulation of your circuit program on the PC
- Generating and printing of an overview chart for the circuit program
- Saving a backup of the circuit program on the hard drive or other media
- Comparing circuit programs
- Easy configuration of blocks
- Transferring the circuit program
 - from LOGO! to the PC and
 - from the PC to LOGO!
- Reading the values of the hour counter
- Setting the TOD
- Summertime/wintertime conversion
- Online test: Display of status changes and process variables of LOGO! in RUN mode:
 - Status of a digital I/O, flags, shift register bits and cursor keys
 - The values of all analog I/Os and flags
 - The results of all blocks
 - The current values (including the times) of selected blocks
- Starting and stopping circuit program execution via the PC (RUN, STOP).

The LOGO! alternatives

As you can see, LOGO!Soft Comfort represents an alternative to conventional engineering methods:

1. You start by developing the circuit program on your desktop.
2. You simulate the circuit program on your computer and verify its functions before you actually implement it in your system.
3. You can add comments to the circuit program and create hardcopies.
4. You save a copy of your circuit program to the file system on your PC, to make it directly available for any modifications.
5. It takes only a few key actions to download the circuit program to LOGO!.

LOGO!Soft Comfort

LOGO!Soft Comfort runs under Windows 95/98, Windows NT 4.0, Windows Me[®], Windows 2000[®], Windows XP[®], Linux[®] and Mac OS X[®]. LOGO!Soft Comfort is capable of client/server operation and offers you a high degree of freedom and comfort for creating your circuit program.

LOGO!Soft Comfort V5.0

This is the current version of LOGO!Soft Comfort. You will find all the functions and the functionality of the devices described in this manual in the version 5.0 and later.

Upgrading LOGO!Soft Comfort versions V1.0 up to V4.0

The upgrade can only be installed for the full version of LOGO!Soft Comfort V1.0, V2.0, V3.0 or V4.0.

Order numbers are in Appendix E.

Note

If a full version is not installed, you can carry out an upgrade as follows:

- Install the software from the CD.
 - When the system prompts you for the previous version, place the old LOGO!Soft Comfort CD in CD drive.
 - Point your browser to the “...\Tools\Application” directory on the CD.
-

Updates and info

You can download demo versions of the software free of charge from the Internet address specified in the preface.

For detailed information on updates, upgrades and the LOGO!Soft Comfort Update Center, refer to LOGO!Soft Comfort’s online help.

7.1 Connecting LOGO! to a PC

Connecting the PC cable

To connect LOGO! to a PC, you need the LOGO! PC cable (order number is found in Appendix E).

Remove the cap or program module (card) from your LOGO! and connect the cable to this socket. Connect the other end of the cable to the serial port of your PC.

Connecting the PC cable to the USB port

If your PC is only equipped with a USB interface (Universal Serial Bus), you will need a converter and a device driver to connect the LOGO! cable to this port. Follow the instructions on the screen when you install the driver for the converter. Make sure you specify the correct Windows OS version when you select the driver.

For current information on converters and drivers, visit our Internet site at

<http://www.siemens.com/automation/service&support>
Article ID 11611048

Switching LOGO! to PC↔LOGO mode

1. Switch the LOGO! with/without display to STOP from your PC (refer to the LOGO!Soft Comfort Online Help), or select the ESC / >Stop command on a device with display and confirm the entry with 'Yes'.

When LOGO! is in STOP and online with the PC, the following PC commands are accepted:

- Switch LOGO! to RUN
- Read/write the circuit program
- Read/write the summertime/wintertime

2. When you start the upload/download in STOP, the following display appears automatically:

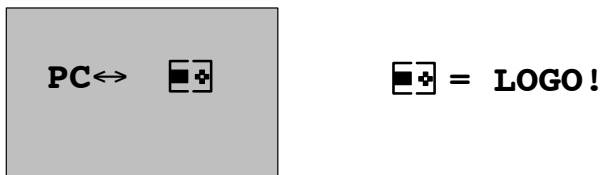

Note

Earlier versions up to 0BA3 with/without display are automatically switched to PC ↔ LOGO mode as follows:

1. Switch off the power supply to LOGO!.
2. Remove the cover or the program module (card) and connect the cable to this socket.
3. Switch on power.

LOGO! switches automatically to PC ↔ LOGO mode.

The PC can now access LOGO! For information on this function, refer to the LOGO!Soft Comfort Online Help.

For more information on LOGO! versions without display, refer to Appendix C.

Closing the PC ↔ LOGO mode

When the data transfer is completed, the connection to the PC is shut down automatically.

Note

If the circuit program created with LOGO!Soft Comfort is password protected, both the circuit program and the password are downloaded to LOGO!. The password prompt is enabled at the end of the data transfer.

The upload of a password protected program created in LOGO! is only possible after the correct password is entered in LOGO!Soft Comfort.

8 Applications

Note

LOGO! sample applications are available to all our customers free of charge on the Internet at <http://www.siemens.com/logo> (go to “Products & Solutions”, then “Applications”).

The examples provided are noncommittal, serve as general information about the fields of application for LOGO!, and may be different to user-specific solutions.

The user operates the system at his own responsibility. We refer the user to the relevant national standards and system-related installation regulations.

Errors cannot be ruled out, and the right to make changes is reserved.

On the Internet you can find the following sample applications (and tips for further applications):

- Irrigation system for greenhouse plants
- Conveyor control system
- Bending machine control system
- Shop window lighting
- Bell system (e.g. in a school)
- Parking lot surveillance
- Outdoor lighting
- Shutter control system
- Domestic outdoor and indoor lighting system
- Control system of a cream stirrer
- Sports hall lighting
- Constant load on 3 consumers
- Sequential control system for cable-welding machines for large cross-sections
- Step switch (e.g. for fans)

- Sequential control for boilers
- Control system for several pump sets with centralized operator control
- Cutting device (e.g. for detonating fuses)
- Monitoring periods of utilization, e.g. of a solar energy system
- Intelligent foot switches, e.g. for speed preselection)
- Elevating platform controls
- Impregnation of textiles, heating and conveyor belt controls
- Silo-filling system

and lots more.

On the Web you can also find descriptions and the corresponding circuit diagrams of the applications. You can read these *.pdf files with the Adobe AcrobatReader. If you have installed LOGO!Soft Comfort on your computer, you can simply click the disk icon to download the relevant circuit programs, which you can then adapt to suit your application and download to LOGO! directly via the PC cable.

Benefits of LOGO!

LOGO! is a particularly useful feature

- For replacing auxiliary switchgear with the integrated LOGO! functions
- For saving wiring and installation work - because LOGO! keeps the wiring "in its head".
- For reducing space requirements for components in the control cabinet/distribution box. A smaller control cabinet/distribution box may provide sufficient space.
- For adding or changing functions, without having to install additional switchgear or change the wiring.

- For offering your customers new, additional functions for domestic and commercial housing installations. Examples:
 - Domestic security systems: LOGO! switches on a lamp at regular intervals or opens and closes the shutters while you are on holiday.
 - Central heating: LOGO! runs the circulation pump only when water or heating is actually required.
 - Refrigerating systems: LOGO! can defrost refrigerating systems at regular intervals to save energy costs.
 - You can illuminate aquaria and terraria on a time-dependent basis.

Last not least you can:

- Use commonly available switches and pushbuttons, which makes it easy to install a domestic system.
- Connect LOGO! directly to your domestic installation; the integrated power supply makes it possible.

Do you want more Info?

For more information about LOGO!, see our web page (see the preface for the URL).

Do you have any suggestions?

There are definitely many more useful applications for LOGO! . If you know of one, why not write to us? We will collect all the suggestions made and distribute as many of them as we can. No matter whether your LOGO! circuit is particularly complex or simple, simply write to us. We shall be delighted to receive all your suggestions.

Write to:

Siemens AG
A&D AS SM MA
PO box 48 48
D-90327 Nuremberg

A Technical data

A.1 General technical data

Criterion	Tested in accordance with	Values
LOGO!Basic Dimensions (WxHxD) Weight Installation		72 x 90 x 55 mm Approx. 190 g on a 35 mm profile rail 4 module widths or wall mounting
LOGO! expansion modules DM8..., AM... Dimensions (WxHxD) Weight Installation		36 x 90 x 53 mm Approx. 90 g on a 35 mm profile rail 2 module widths or wall mounting
LOGO! expansion modules DM16... Dimensions (WxHxD) Weight Installation		72 x 90 x 53 mm Approx. 190 g on a 35 mm profile rail 4 module widths or wall mounting
Climatic conditions		
Ambient temperature Horizontal installation Vertical installation	Low temperature to IEC 60068-2-1 High temperature to IEC 60068-2-2	0 ... 55 °C 0 ... 55 °C
Storage/shipping		-40 °C ... +70 °C
Relative humidity	IEC 60068-2-30	From 10 to 95 % no condensation
Air pressure		795 ... 1080 hPa
Pollutants	IEC 60068-2-42 IEC 60068-2-43	SO ₂ 10 cm ³ /m ³ , 4 days H ₂ S 1 cm ³ /m ³ , 4 days

Criterion	Tested in accordance with	Values
Ambient mechanical conditions		
Protection mode		IP20
Vibrations:	IEC 60068-2-6	5 ... 9 Hz (constant amplitude 3.5 mm) 9 ... 150 Hz (constant acceleration 1 g)
Shock	IEC 60068-2-27	18 shocks (half-sine wave 15g/11 ms)
Drop	IEC 60068-2-31	Drop height 50 mm
Free fall (packaged)	IEC 60068-2-32	1 m
Electromagnetic compatibility (EMC)		
Noise emission	EN 55011/A EN 55022/B EN 50081-1 (domestic area)	Limit class B group 1
Electrostatic discharge	IEC 61000-4-2 Severity 3	8 kV air discharge 6 kV contact discharge
Electromagnetic fields	IEC 61000-4-3	Field strength 10 V/m
HF currents on cables and cable shielding	IEC 61000-4-6	10 V
Burst pulses	IEC 61000-4-4 Severity 3	2 kV (supply and signal lines)
High-energy surge pulse (applies only to LOGO! 230 ...)	IEC 61000-4-5 Severity 3	1 kV (power lines) symmetrical 2 kV (power lines) asymmetrical
Safety to IEC / VDE		
Clearance and creepage distance rating	IEC 60664, IEC 61131-2, EN 50178 cULus to UL 508, CSA C22.2 No. 142 With LOGO! 230 R/RC, also VDE 0631	Fulfilled
Insulation strength	IEC 61131-2	Fulfilled

Criterion	Tested in accordance with	Values
Cycle time		
Cycle time per function		< 0.1 ms
Startup		
Startup time at power-up		typ. 8 s

A.2 Technical data: LOGO! 230...

	LOGO! 230 RC LOGO! 230 RCo
Power supply	
Input voltage	115...240 V AC/DC
Permissible range	85 ... 265 V AC 100 ... 253 V DC
Permissible mains frequency	47 ... 63 Hz
Power consumption	
<ul style="list-style-type: none"> • 115 V AC • 240 V AC • 115 V DC • 240 V DC 	10 ...40 mA 10 ... 25 mA 5 ... 25 mA 5 ... 15 mA
Voltage failure buffering	
<ul style="list-style-type: none"> • 115 V AC/DC • 240 V AC/DC 	typ. 10 ms typ. 20 ms
Power loss at	
<ul style="list-style-type: none"> • 115 V AC • 240 V AC • 115 V DC • 240 V DC 	1.1 ... 4.6 W 2.4 ... 6.0 W 0.5 ... 2.9 W 1.2 ... 3.6 W
Backup of the real-time clock at 25 °C	typ. 80 h
Accuracy of the real-time clock	typ. ± 2 s / day
Digital inputs	
Number	8
Electrical isolation	No

	LOGO! 230 RC LOGO! 230 RCo
Input voltage L1 <ul style="list-style-type: none"> • Signal 0 • Signal 1 • Signal 0 • Signal 1 	<p>< 40 V AC</p> <p>> 79 V AC</p> <p>< 30 V DC</p> <p>> 79 V DC</p>
Input current at <ul style="list-style-type: none"> • Signal 0 • Signal 1 	<p>< 0.03 mA</p> <p>> 0.08 mA</p>
Delay time at <ul style="list-style-type: none"> • 0 to 1 • 1 to 0 	<p>typ. 50 ms</p> <p>typ. 50 ms</p>
Line length (unshielded)	100 m
Digital outputs	
Number	4
Output type	Relay outputs
Electrical isolation	Yes
In groups of	1
Control of a digital input	Yes
Continuous current I_{th}	max. 10 A per relay
Incandescent lamp load (25000 switching cycles) at 230/240 V AC 115/120 V AC	<p>1000 W</p> <p>500 W</p>
Fluorescent tubes with ballast (25000 switching cycles)	10 x 58 W (at 230/240 V AC)
Fluorescent tubes, conventionally compensated (25000 switching cycles)	1 x 58 W (at 230/240 V AC)

Technical data

	LOGO! 230 RC LOGO! 230 RCo
Fluorescent tubes, uncompensated (25000 switching cycles)	10 x 58 W (at 230/240 V AC)
Short circuit-proof cos 1	Power protection B16 600A
Short circuit-proof cos 0.5 to 0.7	Power protection B16 900A
Derating	none; across the entire temperature range
Parallel output circuits for power increase	Not permitted
Protection of output relay (if desired)	max. 16 A, characteristic B16
Switching rate	
Mechanical	10 Hz
Ohmic load/lamp load	2 Hz
Inductive load	0.5 Hz

A.3 Technical data: LOGO! DM8 230R and LOGO! DM16 230R

	LOGO! DM8 230R	LOGO! DM16 230R
Power supply		
Input voltage	115...240 V AC/DC	115 ... 240 V AC/DC
Permissible range	85 ... 265 V AC 100 ... 253 V DC	85 ... 265 V AC 100 ... 253 V DC
Permissible mains frequency	47 ... 63 Hz	47 ... 63 Hz
Power consumption		
<ul style="list-style-type: none"> • 115 V AC • 240 V AC • 115 V DC • 240 V DC 	10 ... 30 mA 10 ... 20 mA 5 ... 15 mA 5 ... 10 mA	10 ... 60 mA 10 ... 40 mA 5 ... 25 mA 5 ... 20 mA
Voltage failure buffering		
<ul style="list-style-type: none"> • 115 V AC/DC • 240 V AC/DC 	typ. 10 ms typ. 20 ms	typ. 10 ms typ. 20 ms
Power loss at		
<ul style="list-style-type: none"> • 115 V AC • 240 V AC • 115 V DC • 240 V DC 	1.1 ... 3.5 W 2.4 ... 4.8 W 0.5 ... 1.8 W 1.2 ... 2.4 W	1.1 ... 4.5 W 2.4 ... 5.5 W 0.6 ... 2.9 W 1.2 ... 4.8 W
Backup of the real-time clock at 25 °C		
Accuracy of the real-time clock		
Digital inputs		
Number	4	8
Electrical isolation	No	No

	LOGO! DM8 230R	LOGO! DM16 230R
Input voltage L1		
<ul style="list-style-type: none"> • Signal 0 • Signal 1 • Signal 0 • Signal 1 	<p>< 40 V AC</p> <p>> 79 V AC</p> <p>< 30 V DC</p> <p>> 79 V DC</p>	<p>< 40 V AC</p> <p>> 79 V AC</p> <p>< 30 V DC</p> <p>> 79 V DC</p>
Input current at		
<ul style="list-style-type: none"> • Signal 0 • Signal 1 	<p>< 0.03 mA</p> <p>> 0.08 mA</p>	<p>< 0.05 mA</p> <p>> 0.08 mA</p>
Delay time at		
<ul style="list-style-type: none"> • 0 to 1 • 1 to 0 	<p>typ. 50 ms</p> <p>typ. 50 ms</p>	<p>typ. 50 ms</p> <p>typ. 50 ms</p>
Line length (unshielded)	100 m	100 m
Digital outputs		
Number	4	8
Output type	Relay outputs	Relay outputs
Electrical isolation	Yes	Yes
In groups of	1	1
Control of a digital input	Yes	Yes
Continuous current I_{th}	max. 5 A per relay	max. 5 A per relay
Incandescent lamp load (25000 switching cycles) at		
230/240 V AC	1000 W	1000 W
115/120 V AC	500 W	500 W
Fluorescent tubes with ballast (25000 switching cycles)	10 x 58 W (at 230/240 V AC)	10 x 58 W (at 230/240 V AC)
Fluorescent tubes, conven- tionally compensated (25000 switching cycles)	1 x 58 W (at 230/240 V AC)	1 x 58 W (at 230/240 V AC)

	LOGO! DM8 230R	LOGO! DM16 230R
Fluorescent tubes, uncompensated (25000 switching cycles)	10 x 58 W (at 230/240 V AC)	10 x 58 W (at 230/240 V AC)
Short circuit-proof cos 1	Power protection B16 600A	Power protection B16 600A
Short circuit-proof cos 0.5 to 0.7	Power protection B16 900A	Power protection B16 900A
Derating	none; across the entire temperature range	None; across the entire temperature range
Parallel output circuits for power increase	Not permitted	Not permitted
Protection of output relay (if desired)	max. 16 A, characteristic B16	max. 16 A, characteristic B16
Switching rate		
Mechanical	10 Hz	10 Hz
Ohmic load/lamp load	2 Hz	2 Hz
Inductive load	0.5 Hz	0.5 Hz

A.4 Technical data: LOGO! 24...

	LOGO! 24 LOGO! 24o
Power supply	
Input voltage	24 V DC
Permissible range	20.4 ... 28.8 V DC
Reverse polarity protection	Yes
Permissible mains frequency	
Power consumption from 24 V DC	30 ... 55 mA 0.3 A per output
Voltage failure buffering	
Power loss at 24 V	0.7 ... 1.3 W
Backup of the real-time clock at 25 °C	
Accuracy of the real-time clock	
Digital inputs	
Number	8
Electrical isolation	No
Input voltage	L+
<ul style="list-style-type: none"> • Signal 0 • Signal 1 	<ul style="list-style-type: none"> < 5 V DC > 8 V DC

	LOGO! 24 LOGO! 24o
Input current at <ul style="list-style-type: none"> • Signal 0 • Signal 1 	< 1.0 mA (I1...I6) < 0.05 mA (I7, I8) > 1.5 mA (I1... I6) > 0.1 mA (I7, I8)
Delay time at <ul style="list-style-type: none"> • 0 to 1 • 1 to 0 	typ. 1.5 ms <1.0 ms (I5, I6) typ. 1.5 ms <1.0 ms (I5, I6)
Line length (unshielded)	100 m
Analog inputs	
Number	2 (I7 = AI1, I8 = AI2)
Range	0 ... 10 V DC input impedance 78 k Ω
Cycle time for analog value generation	300 ms
max. input voltage	28.8 V DC
Line length (shielded and twisted)	10 m
Digital outputs	
Number	4
Output type	Transistor, current-sourcing ⁽¹⁾
Electrical isolation	No
In groups of	
Control of a digital input	Yes
Output voltage	\triangle Supply voltage
Output current	max. 0.3 A
Continuous current I_{th}	

Technical data

	LOGO! 24 LOGO! 24o
Incandescent lamp load (25000 switching cycles) at	
Fluorescent tubes with ballast (25000 switching cycles)	
Fluorescent tubes, conventionally compensated (25000 switching cycles)	
Fluorescent tubes, uncompensated (25000 switching cycles)	
Short circuit-proof and over-load-proof	Yes
Short circuit current limitation	Approx. 1 A
Derating	none; across the entire temperature range
Short circuit-proof cos 1	
Short circuit-proof cos 0.5 to 0.7	
Parallel output circuit for power increase	Not permitted
Protection of output relay (if desired)	
Switching rate ⁽²⁾	
Mechanical	
Electrical	10 Hz
Ohmic load/lamp load	10 Hz
Inductive load	0.5 Hz

(1): When LOGO! 24, LOGO! 24o, LOGO! DM8 24 or LOGO! DM16 24 are switched on, signal 1 is sent to the digital outputs for about 50 microseconds. Take this into account, especially when using devices that react to short pulses.

(2): The maximum switching rate is only dependent on the switching program's cycle time.

A.5 Technical data: LOGO! DM8 24 and LOGO! DM16 24

	LOGO! DM8 24	LOGO! DM16 24
Power supply		
Input voltage	24 V DC	24 V DC
Permissible range	20.4 ... 28.8 V DC	20.4 ... 28.8 V DC
Reverse polarity protection	Yes	Yes
Permissible mains frequency		
Power consumption from 24 V DC	30 ... 45 mA 0.3 A per output	30 ... 45 mA 0.3 A per output
Voltage failure buffering		
Power loss at 24 V	0.8 ... 1.1 W	0.8 ... 1.7 W
Backup of the real-time clock at 25 °C		
Accuracy of the real-time clock		
Digital inputs		
Number	4	8
Electrical isolation	No	No
Input voltage	L+	L+
<ul style="list-style-type: none"> • Signal 0 • Signal 1 	< 5 V DC > 8 V DC	< 5 V DC > 12 V DC

	LOGO! DM8 24	LOGO! DM16 24
Input current at		
• Signal 0	< 1.0 mA	< 1 mA
• Signal 1	> 1.5 mA	> 2 mA
Delay time at		
• 0 to 1	typ. 1.5 ms	typ. 1.5 ms
• 1 to 0	typ. 1.5 ms	typ. 1.5 ms
Line length (unshielded)	100 m	100 m
Digital outputs		
Number	4	8
Output type	Transistor, current-sourcing ⁽¹⁾	Transistor, current-sourcing ⁽¹⁾
Electrical isolation	No	No
In groups of		
Control of a digital input	Yes	Yes
Output voltage	△ Supply voltage	△ Supply voltage
Output current	max. 0.3 A	max. 0.3 A
Continuous current I_{th}		
Incandescent lamp load (25000 switching cycles) at		
Fluorescent tubes with ballast (25000 switching cycles)		
Fluorescent tubes, conventionally compensated (25000 switching cycles)		
Fluorescent tubes, uncompensated (25000 switching cycles)		
Short circuit-proof and overload-proof	Yes	Yes
Short circuit current limitation	Approx. 1 A	Approx. 1 A

	LOGO! DM8 24	LOGO! DM16 24
Derating	none; across the entire temperature range	None; across the entire temperature range
Short circuit-proof cos 1		
Short circuit-proof cos 0.5 to 0.7		
Parallel output circuit for power increase	Not permitted	Not permitted
Protection of output relay (if desired)		
Switching rate		
Mechanical		
Electrical	10 Hz	10 Hz
Ohmic load/lamp load	10 Hz	10 Hz
Inductive load	0.5 Hz	0.5 Hz

(1): When LOGO! 24, LOGO! 24o, LOGO! DM8 24 or LOGO! DM16 24 are switched on, signal 1 is sent to the digital outputs for about 50 microseconds. Take this into account, especially when using devices that react to short pulses.

A.6 Technical data: LOGO! 24RC...

	LOGO! 24RC LOGO! 24RC _o
Power supply	
Input voltage	24 V AC/DC
Permissible range	20.4 ... 26.4 V AC 20.4 ... 28.8 V DC
Reverse polarity protection	
Permissible mains frequency	47 ... 63 Hz
Power consumption	
<ul style="list-style-type: none"> • 24 V AC • 24 V DC 	40 ... 110 mA 20 ... 75 mA
Voltage failure buffering	typ. 5 ms
Power loss	
<ul style="list-style-type: none"> • 24 V AC • 24 V DC 	0.9 ... 2.7 W 0.4 ... 1.8 W
Backup of the real-time clock at 25 °C	typ. 80 h
Accuracy of the real-time clock	typ. ± 2 s / day
Digital inputs	
Number	8, optional P action or N action
Electrical isolation	No
Input voltage	L
<ul style="list-style-type: none"> • Signal 0 • Signal 1 	< 5 V AC/DC > 12 V AC/DC

	LOGO! 24RC LOGO! 24RCo
Input current at	
• Signal 0	< 1.0 mA
• Signal 1	> 2.5 mA
Delay time at	
• 0 to 1	typ. 1.5 ms
• 1 to 0	typ. 15 ms
Line length (unshielded)	100 m
Analog inputs	
Number	
Range	
max. Input voltage	
Digital outputs	
Number	4
Output type	Relay outputs
Electrical isolation	Yes
In groups of	1
Control of a digital input	Yes
Output voltage	
Output current	
Continuous current I_{th}	max. 10 A per relay
Incandescent lamp load (25000 switching cycles) at	1000 W
Fluorescent tubes with ballast (25000 switching cycles)	10 x 58 W
Fluorescent tubes, conventionally compensated (25000 switching cycles)	1 x 58 W

Technical data

	LOGO! 24RC LOGO! 24RCo
Fluorescent tubes, uncompensated (25000 switching cycles)	10 x 58 W
Short circuit-proof and over-load-proof	
Short circuit current limitation	
Derating	none; across the entire temperature range
Short circuit-proof cos 1	Power protection B16, 600A
Short circuit-proof cos 0.5 to 0.7	Power protection B16, 900A
Parallel output circuits for power increase	Not permitted
Protection of output relay (if desired)	max. 16 A, characteristic B16
Switching rate	
Mechanical	10 Hz
Electrical	
Ohmic load/lamp load	2 Hz
Inductive load	0.5 Hz

A.7 Technical data: LOGO! DM8 24 R and LOGO! DM16 24 R

	LOGO! DM8 24 R	LOGO! DM16 24R
Power supply		
Input voltage	24 V AC/DC	24 V DC
Permissible range	20.4 ... 26.4 V AC 20.4 ... 28.8 V DC	20.4 ... 28.8 V DC
Reverse polarity protection		Yes
Permissible mains frequency	47 ... 63 Hz	
Power consumption		
<ul style="list-style-type: none"> • 24 V AC • 24 V DC 	40 ... 110 mA 20 ... 75 mA	30 ... 90 mA
Voltage failure buffering	typ. 5 ms	typ. 5 ms
Power loss		
<ul style="list-style-type: none"> • 24 V AC • 24 V DC 	0.9 ... 2.7 W 0.4 ... 1.8 W	0.7 ... 2.5 W
Backup of the real-time clock at 25 °C		
Accuracy of the real-time clock		
Digital inputs		
Number	4, optional P action or N action	8
Electrical isolation	No	No
Input voltage	L	
<ul style="list-style-type: none"> • Signal 0 • Signal 1 	< 5 V AC/DC > 12 V AC/DC	< 5 V DC > 12 V DC

	LOGO! DM8 24 R	LOGO! DM16 24R
Input current at <ul style="list-style-type: none"> • Signal 0 • Signal 1 	< 1.0 mA > 2.5 mA	< 1.0 mA > 2.0 mA
Delay time at <ul style="list-style-type: none"> • 0 to 1 • 1 to 0 	typ. 1.5 ms typ. 15 ms	typ. 1.5 ms typ. 1.5 ms
Line length (unshielded)	100 m	100 m
Digital outputs		
Number	4	8
Output type	Relay outputs	Relay outputs
Electrical isolation	Yes	Yes
In groups of	1	1
Control of a digital input	Yes	Yes
Output voltage		
Output current		
Continuous current I_{th}	max. 5 A per relay	max. 5 A per relay
Incandescent lamp load (25000 switching cycles) at	1000 W	1000 W
Fluorescent tubes with ballast (25000 switching cycles)	10 x 58 W	10 x 58 W
Fluorescent tubes, conventionally compensated (25000 switching cycles)	1 x 58 W	1 x 58 W
Fluorescent tubes, uncompensated (25000 switching cycles)	10 x 58 W	10 x 58 W
Short circuit-proof and overload-proof		

	LOGO! DM8 24 R	LOGO! DM16 24R
Short circuit current limitation		
Derating	none; across the entire temperature range	None; across the entire temperature range
Short circuit-proof cos 1	Power protection B16, 600A	Power protection B16 600A
Short circuit-proof cos 0.5 to 0.7	Power protection B16, 900A	Power protection B16 900A
Parallel output circuits for power increase	Not permitted	Not permitted
Protection of output relay (if desired)	max. 16 A, characteristic B16	max. 16 A, characteristic B16
Switching rate		
Mechanical	10 Hz	10 Hz
Electrical		
Ohmic load/lamp load	2 Hz	2 Hz
Inductive load	0.5 Hz	0.5 Hz

A.8 Technical data: LOGO! 12/24... and LOGO! DM8 12/24R

	LOGO! 12/24RC LOGO! 12/24RCo	LOGO! DM8 12/24R
Power supply		
Input voltage	12/24 V DC	12/24 V DC
Permissible range	10.8 ... 28.8 V DC	10.8 ... 28.8 V DC
Reverse polarity protection	Yes	Yes
Power consumption <ul style="list-style-type: none"> • 12 V DC • 24 V DC 	30 ... 140 mA 20 ... 75 mA	30 ... 140 mA 20 ... 75 mA
Voltage failure buffering <ul style="list-style-type: none"> • 12 V DC • 24 V DC 	typ. 2 ms typ. 5 ms	typ. 2 ms typ. 5 ms
Power loss <ul style="list-style-type: none"> • 12 V DC • 24 V DC 	0.3 ... 1.7 W 0.4 ... 1.8 W	0.3 ... 1.7 W 0.4 ... 1.8 W
Backup of the real-time clock at 25 °C	typ. 80 h	
Accuracy of the real-time clock	typ. ± 2 s / day	
Electrical isolation	No	No
Digital inputs		
Number	8	4
Electrical isolation	No	No
Input voltage L+ <ul style="list-style-type: none"> • Signal 0 • Signal 1 	< 5 V DC > 8 V DC	< 5 V DC > 8 V DC

	LOGO! 12/24RC LOGO! 12/24RCo	LOGO! DM8 12/24R
Input current at <ul style="list-style-type: none"> • Signal 0 • Signal 1 	< 1.0 mA (I1...I6) < 0.05 mA (I7, I8) > 1.5 mA (I1... I6) > 0.1 mA (I7, I8)	< 1.0 mA > 1.5 mA
Delay time at <ul style="list-style-type: none"> • 0 to 1 • 1 to 0 	typ. 1.5 ms <1.0 ms (I5, I6) typ. 1.5 ms <1.0 ms (I5, I6)	typ. 1.5 ms typ. 1.5 ms
Line length (unshielded)	100 m	100 m
Analog inputs		
Number	2 (I7 = AI1, I8 = AI2)	
Range	0 ... 10 V DC input impedance 76 kΩ	
Cycle time for analog value generation	300 ms	
max. Input voltage	28.8 V DC	
Line length (shielded and twisted)	10 m	
Digital outputs		
Number	4	4
Output type	Relay outputs	Relay outputs
Electrical isolation	Yes	Yes
In groups of	1	1
Control of a digital input	Yes	Yes
Output voltage		
Output current		

Technical data

	LOGO! 12/24RC LOGO! 12/24RCo	LOGO! DM8 12/24R
Continuous current I_{th} (per terminal)	max. 10 A per relay	max. 5 A per relay
Incandescent lamp load (25000 switching cycles) at	1000 W	1000 W
Fluorescent tubes with ballast (25000 switching cycles)	10 x 58 W	10 x 58 W
Fluorescent tubes, conventionally compensated (25000 switching cycles)	1 x 58 W	1 x 58 W
Fluorescent tubes, uncompensated (25000 switching cycles)	10 x 58 W	10 x 58 W
Short circuit-proof and overload-proof		
Short circuit current limitation		
Derating	none; across the entire temperature range	none; across the entire temperature range
Short circuit-proof cos 1	Power protection B16 600A	Power protection B16 600A
Short circuit-proof cos 0.5 to 0.7	Power protection B16 900A	Power protection B16 900A
Parallel output circuits for power increase	Not permitted	Not permitted
Protection of output relay (if desired)	max. 16 A, characteristic B16	max. 16 A, characteristic B16
Switching rate		
Mechanical	10 Hz	10 Hz
Electrical		
Ohmic load/lamp load	2 Hz	2 Hz
Inductive load	0.5 Hz	0.5 Hz

A.9 Switching capacity and service life of the relay outputs

Ohmic load

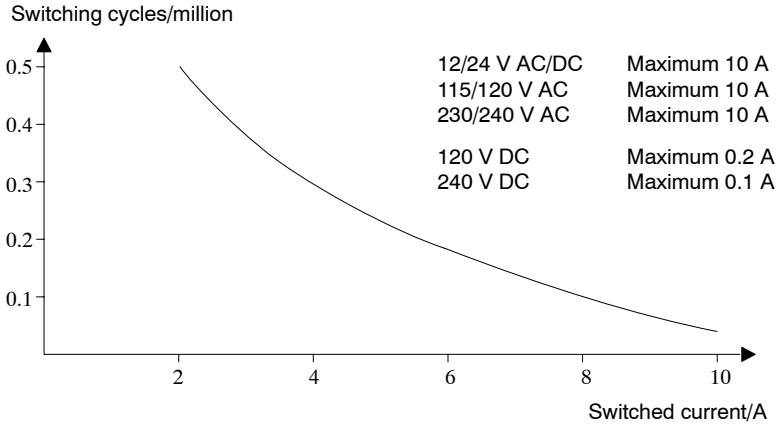

Figure A Switching capacity and service life of the contacts with ohmic load (heating)

Inductive load

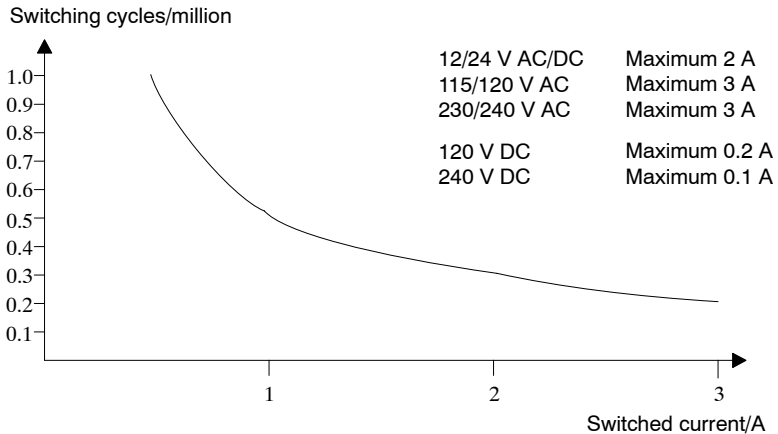

Figure B Switching capacity and service life of the contacts with high inductive load to IEC 947-5-1 DC 13/AC 15 (contactors, solenoid coils, motors)

A.10 Technical data: LOGO! AM 2

LOGO! AM 2	
Power supply	
Input voltage	12/24 V DC
Permissible range	10.8 ... 28.8 V DC
Power consumption	25 ... 50 mA
Voltage failure buffering	typ. 5 ms
Power loss at	
• 12 V	0.3 ... 0.6 W
• 24 V	0.6 ... 1.2 W
Electrical isolation	No
Reverse polarity protection	Yes
Ground terminal	for connecting ground and shielding of the analog measuring line.
Analog inputs	
Number	2
Type	Unipolar
Input range	0 ... 10 V DC (input impedance 76 k Ω) or 0 ... 20 mA (input impedance <250 Ω)
Resolution	10 bit, normalized to 0 ... 1000
Cycle time for analog value generation	50 ms
Electrical isolation	No
Line length (shielded and twisted)	10 m
Encoder supply voltage	none
Error limit	+/- 1.5 %
Interference frequency suppression	55 Hz

A.11 Technical data: LOGO! AM 2 PT100

LOGO! AM 2 PT100	
Power supply	
Input voltage	12/24 V DC
Permissible range	10.8 ... 28.8 V DC
Power consumption	25 ... 50 mA
Voltage failure buffering	typ. 5 ms
Power loss at	
• 12 V	0.3 ... 0.6 W
• 24 V	0.6 ... 1.2 W
Electrical isolation	No
Reverse polarity protection	Yes
Ground terminal	for connecting ground and shielding of the measuring line
Sensor inputs	
Number	2
Type	RTD Pt100
Connection of sensors	
• 2-wire technique	Yes
• 3-wire technique	Yes
Measurement range	–50 °C ... +200 °C –58 °F ... +392 °F
Settings for the measurement display on the basic module:	
• 1 °C steps	Offset: –200, Gain: 25
• 0.25 °C steps (rounded to one decimal)	Offset: –200, Gain: 250
• 1 °C steps	Offset: –128, Gain: 45
• 0.25 °C steps (rounded to one decimal)	Offset: –128, Gain: 450

Technical data

	LOGO! AM 2 PT100
Curve linearization	No
Measuring current I _c	1.1 mA
Measurement rate	depends on the installation typical: 50 ms
Resolution	0.25 °C
Error limits • 0 °C ... +200 °C • -50 °C ... +200 °C	of the final measured value: +/- 1.0 % +/- 1.5 %
Electrical isolation	No
Cable length (shielded)	10 m
Interference frequency suppression	55 Hz

A.12 Technical data: LOGO! AM 2 AQ

LOGO! AM 2 AQ	
Power supply	
Input voltage	24 V DC
Permissible range	20.4 ... 28.8 V DC
Power consumption	25 ... 50 mA
Voltage failure buffering	typ. 5 ms
Power loss at 24 V	0.6 ... 1.2 W
Electrical isolation	No
Reverse polarity protection	Yes
Ground terminal	for connecting ground and shielding of the analog output line.
Analog outputs	
Number	2
Output range	0 ... 10 V DC
Load resistor	5 k Ω
Resolution	10 bit, normalized to 0 ... 1000
Cycle time for analog output	depending on installation (50 ms)
Electrical isolation	No
Line length (shielded and twisted)	10 m
Error limit	+/- 2.5 %
Short circuit protection	Yes
Response at short-circuit	affected output = 0 V neighboring output reverts
Overload protection	Yes
Response at overload	affected output = 0 V neighboring output reverts

A.13 Technical data: CM EIB/KNX

CM EIB/KNX	
Mechanical data	
Dimensions (WxHxD)	36 x 90 x 55 mm
Weight	Approx. 107 g
Installation	on a 35 mm profile rail 2 module widths or wall mounting must be mounted as the last module on the right of LOGO!
Power supply	
Input voltage	24 V AC/DC
Permissible range	-15% ... +10% AC -15% ... +20% DC
Power consumption from power supply	max. 25 mA
Power consumption via bus	5 mA
EIB data transmission rate	9600 baud
Connections	
Digital inputs (I)	virtual max. 16
Digital outputs (Q)	virtual max. 12
Analog inputs (AI)	virtual max. 8
Analog outputs (AA)	virtual max. 2
Group addresses	max. 56
Associations	max. 56
Climatic conditions	
Climatic withstand capability	EN 50090-2-2
Ambient operating conditions	0 ... 55 °C natural convection
Storage and transport temperature	-40 °C ... +70 °C
Relative humidity	95 % at +25 °C (not condensing)
Electrical safety	
Type of protection	IP 20 (in accordance with EN 60529)

	CM EIB/KNX
Interference suppression	EN 55011 (limit class B)
Certification	VDE 0631 IEC 61131-2
Overvoltage protection	Slow-blowing fuse 80 mA (recommended)
Electromagnetic compatibility (EMC)	
EMC requirements	Complies with EN 61000-6-1 and EN 61000-6-2
Approval	
	KNX/EIB certified UL 508 FM
CE mark	
	In accordance with the EMC guideline (residential and functional buildings), low voltage guideline

A.14 Technical data: CM AS Interface

CM AS Interface	
Mechanical data	
Dimensions (WxHxD)	36 x 90 x 58 mm
Weight	Approx. 90 g
Installation	on a 35 mm profile rail 2 module widths or wall mounting must be mounted as the last module on the right of LOGO!
Power supply	
Input voltage	24 V DC
Permissible range	19.2 ... 28.8 V DC
Reverse polarity protection	Yes
Total current drain	I_{tot} max. 70 mA
Connections	
Digital inputs (I)	the next four inputs after the physical inputs of LOGO! ($I_n ... I_{n+3}$)
Digital outputs (Q)	the next four outputs after the physical outputs of LOGO! ($Q_n ... Q_{n+3}$)
I/O configuration (hex)	7
ID code (hex)	F
ID1 code (hex)	F (default, variable from 0 ... F)
ID2 code (hex)	F
Bus connection	AS interface in accordance with speci- fication
Analog inputs (AI)	none
Analog outputs (AQ)	none
Climatic conditions	
Ambient operating conditions	0 °C ... +55 °C
Storage temperature	-40 °C ... +70 °C

	CM AS Interface
Electrical safety	
Electrical data	to AS interface specification
Type of protection	IP 20
Interference suppression	Limit class A
Approval	
	IEC 61131-2, EN 50178 cULus to UL 508 CSA C22.2 No. 142

A.15 Technical data: LOGO!Power 12 V

LOGO! Power 12 V is a primary-switched power supply unit for LOGO! devices. Two current ranges are available.

	LOGO! Power 12 V / 1.9 A	LOGO! Power 12 V / 4.5 A
Input data		
Input voltage	100 ... 240 V AC	
Permissible range	85 ... 264 V AC	
Permissible mains frequency	47 ... 63 Hz	
Voltage failure buffering	> 40 ms (at 187 V AC)	
Input current	0.53 ... 0.3 A	1.13 ... 0.61 A
Make current (25 °C)	≤ 15 A	≤ 30 A
Device protection	Internal	
Recommended circuit breaker (IEC 898) in mains line	≥ 16 A characteristic B ≥ 10 A characteristic C	
Output data		
Output voltage	12 V DC	
Overall tolerance	+/-3 %	
Adjustment range	10.5 ... 16.1 V DC	
Residual ripple	< 200/300 mV _{pp}	
Output current	1.9 A	4.5 A
Overcurrent limiting	typ. 2.5 A	typ. 5.9 A
Efficiency	typ. 80 %	typ. 85 %
Parallel circuit for power increase	Yes	
Electromagnetic compatibility		
Interference suppression	EN 50081-1, Class B to EN 55022	
Interference immunity	EN 61000-6-2, EN 61000-4-2/-3/-4/-5/-6/-11	

	LOGO! Power 12 V / 1.9 A	LOGO! Power 12 V / 4.5 A
Safety		
Electrical isolation, primary/ secondary	Yes, SELV (to EN 60950 and EN 50178)	
Safety class	II	
Protection mode	IP 20 (to EN 60529)	
CE marking	Yes	
UL/cUL certification	Yes; UL 508 / UL 60950	
FM approval	Yes; Class I, Div. 2, T4	
GL approval	Yes	
General details		
Ambient temperature range	−20 ... +55 °C, natural convection	
Storage and shipping temperature	−40 ... +70 °C	
Connections at input	One terminal (1 x 2.5 mm ² or 2 x 1.5 mm ²) per L1 and N	
Connections at output	Two terminals (1x.2.5 mm ² or 2 x 1.5 mm ²) per + and −	
Installation	On 35 mm DIN rail, snap-on	
Dimensions in mm (WxHxD)	54 x 80 x 55	72 x 90 x 55
Approx. weight	0.2 kg	0.3 kg

A.16 Technical data: LOGO!Power 24 V

LOGO! Power 24 V is a primary-switched power supply module for LOGO! devices. Two current ranges are available.

	LOGO! Power 24 V / 1.3 A	LOGO! Power 24 V / 2.5 A
Input data		
Input voltage	100 ... 240 V AC	
Permissible range	85 ... 264 V AC	
Permissible mains frequency	47 ... 63 Hz	
Voltage failure buffering	40 ms (at 187 V AC)	
Input current	0.70 ... 0.35 A	1.22 ... 0.66 A
Inrush current (25 °C)	< 15 A	< 30 A
Device protection	Internal	
Recommended circuit breaker (IEC 898) in mains line	≥ 16 A characteristic B ≥ 10 A characteristic C	
Output data		
Output voltage	24 V DC	
Overall tolerance	+/- 3 %	
Adjustment range	22.2 ... 26.4 V DC	
Residual ripple	< 200/300 mV _{pp}	
Output current	1.3 A	2.5 A
Overcurrent limiting	typ. 2.0 A	typ. 3.4 A
Efficiency	> 82 %	> 87 %
Parallel circuit for power increase	Yes	
Electromagnetic compatibility		
Interference suppression	EN 50081-1, Class B to EN 55022	
Interference immunity	EN 61000-6-2, EN 61000-4-2/-3/-4/-5/-6/-11	

	LOGO! Power 24 V / 1.3 A	LOGO! Power 24 V / 2.5 A
Safety		
Electrical isolation, primary/ secondary	Yes, SELV (to EN 60950 and EN 50178)	
Safety class	II	
Protection mode	IP 20 (to EN 60529)	
CE marking	Yes	
UL/cUL certification	Yes; UL 508 / UL 60950	
FM approval	Yes; Class I, Div. 2, T4	
GL approval	Yes	
General details		
Ambient temperature range	−20 ... +55°C, natural convection	
Storage and shipping temperature	−40 ... +70°C	
Connections at input	One terminal (1 x 2.5 mm ² or 2 x 1.5 mm ²) per L1 and N	
Connections at output	Two terminals (1x2.5 mm ² or 2 x 1.5 mm ²) per + and −	
Installation	On 35 mm DIN rail, snap-on	
Dimensions in mm (WxHxD)	54 x 80 x 55	72 x 90 x 55
Approx. weight	0.2 kg	0.3 kg

A.17 Technical data: LOGO! Contact 24/230

LOGO! Contact 24 and LOGO! Contact 230 are switching modules for direct switching of ohmic loads up to 20 Amps and motors up to 4 kW (without noise emission, hum-free).

	LOGO! Contact 24	LOGO! Contact 230
Operating voltage	24 V DC	230 V AC; 50/60 Hz
Switching capacity		
Utilization category AC-1: Switching of ohmic loads at 55 °C Operating current at 400 V Output with three-phase loads at 400 V	20 A 13 kW	
Utilization category AC-2, AC-3: Motor with slip ring induction/cage armature Operating current at 400 V Output with three-phase loads at 400 V	8.4 A 4 kW	
Short-circuit protection: Assignment type 1 Assignment type 2	25 A 10 A	
Connecting leads	Fine-wire with wire end ferrules Solid wire 2 x (0.75 to 2.5) mm ² 2 x (1 to 2.5) mm ² 1 x 4 mm ²	
Dimensions (WxHxD)	36 x 72 x 55	
Ambient temperature	-25 ... +55 °C	
Storage temperature	-50 ... +80 °C	

B Determining the cycle time

The program cycle is the complete execution of the circuit program, that is, primarily the reading in of the inputs, the processing of the circuit program and the subsequent reading out of the outputs. The cycle time is the time required to execute a circuit program once in full.

The time required for a program cycle can be determined using a short test program. This test program is created in LOGO! and returns a value during its execution in parameter assignment mode from which the current cycle time is derived.

Test program

1. Create the test program by linking an output to a threshold trigger and connecting the trigger input with an inverted flag.

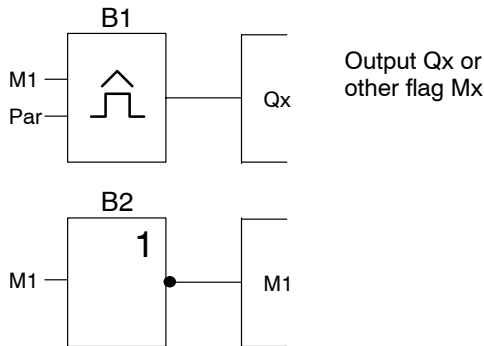

2. Configure the threshold trigger as shown below. A pulse is generated in each program cycle due to the inverted flag. The trigger interval is set to 2 seconds.

B1 **1+**
On =1000
Off=0000

Press

B1 **2**
G_T=02:00s

- Now start the circuit program and switch LOGO! to parameter assignment mode. In this mode, view the trigger parameters.

B1
On =1000
Off =0000
fa =0086

f_a = total of measured pulses per timeba

- The reciprocal value of f_a is equivalent to the LOGO! execution time of the current circuit program in its memory.

$$1/f_a = \text{cycle time in s}$$

Explanation

The inverted flag block changes its output signal at each program execution. Thus, one logic level (high or low) width is exactly equivalent to the length of one cycle. Hence, a period lasts 2 cycles.

The threshold trigger indicates the ratio of periods per 2 seconds, which results in the ratio of cycles per second.

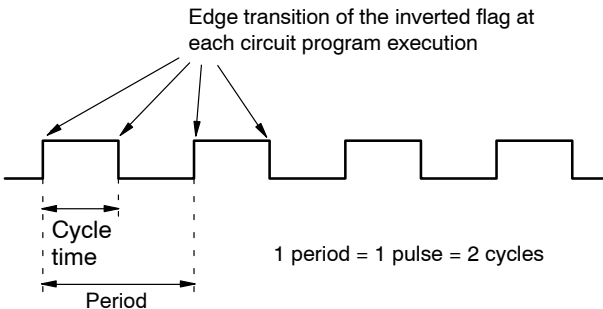

C LOGO! without display

Because some specific applications do not require operator control and monitoring units such as buttons or a display, we provide the LOGO! 12/24RCo, LOGO! 24o, LOGO! 24RCo and LOGO! 230RCo versions without display.

View of a LOGO! 230RCo, for example:

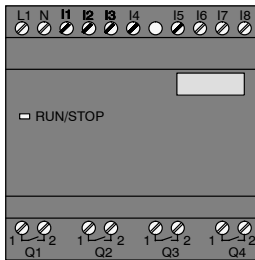

Less is definitely more!

The versions without display offer you the following benefits:

- Even more cost-effective without the operating element.
- Requires less switch cabinet space than conventional hardware.
- Substantial benefits with regard to flexibility and prime costs compared to stand-alone electronic switchgear.
- Of advantage even for applications in which merely two or three conventional switching devices can be replaced.
- Very easy to use.
- Access protected.
- Compatible to LOGO! versions with display.
- Offers the option to read data by means of LOGO!Soft Comfort.

Creating a circuit program without operator panel

There are two ways to create a circuit program for a LOGO! without display:

- You create the circuit program with LOGO!Soft Comfort on your PC and then download it to LOGO! (see Chapter 7).
- You download the circuit program from a LOGO! program module (card) to your LOGO! without display (see Chapter 6).

Operating characteristics

LOGO! is ready for operation when power is switched on. Switching off a LOGO! without display is equivalent to disconnecting the power supply, e.g. as if you were removing the plug.

The circuit program of LOGO!...o versions cannot be started or stopped by means of buttons. This is why the LOGO!...o versions have other startup characteristics:

Startup characteristics

If there is no circuit program in LOGO! or on the inserted program module (card), LOGO! remains in STOP.

If there is a valid circuit program in LOGO! memory, the LOGO! automatically switches from STOP to RUN when power is switched on.

The circuit program on an inserted program module (card) is automatically copied to LOGO!, immediately after power is switched on. The existing circuit program in LOGO! memory is overwritten. The system automatically changes from STOP to RUN.

Provided the PC cable is connected to LOGO!, you can download the circuit program to LOGO! and start it by means of LOGO!Soft Comfort PC software (see Chapter 7.1).

Operating status indication

Operating states, e.g. Power On, RUN and STOP are indicated by an LED on the front hood.

- Red LED: Power On/STOP
- Green LED: Power On/RUN

The red LED is lit after Power On and in all LOGO! states other than RUN. The green LED is lit when LOGO! is in RUN mode.

Reading current data

LOGO!Soft Comfort (see Chapter 7) provides an online test for reading the current data of all functions while the system is in RUN.

If your LOGO! without display holds a protected program module (card), you cannot read the current data unless you enter the correct password for your the circuit program. The circuit program is otherwise deleted from LOGO! memory when you remove the program module (card) to connect the PC cable, for example (see Chapter 6.1).

D LOGO! menu structure

Menu overview

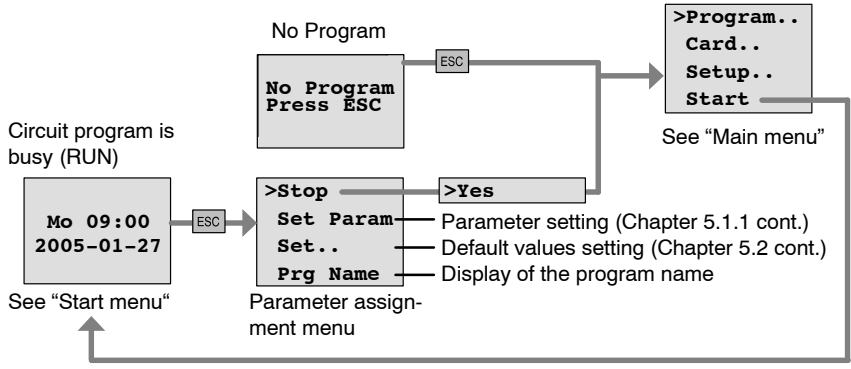

Main menu (ESC / >Stop)

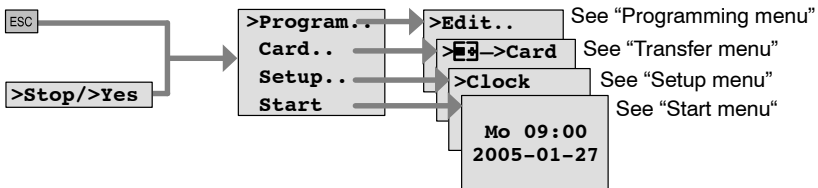

Programming menu (ESC / >Stop → >Program)

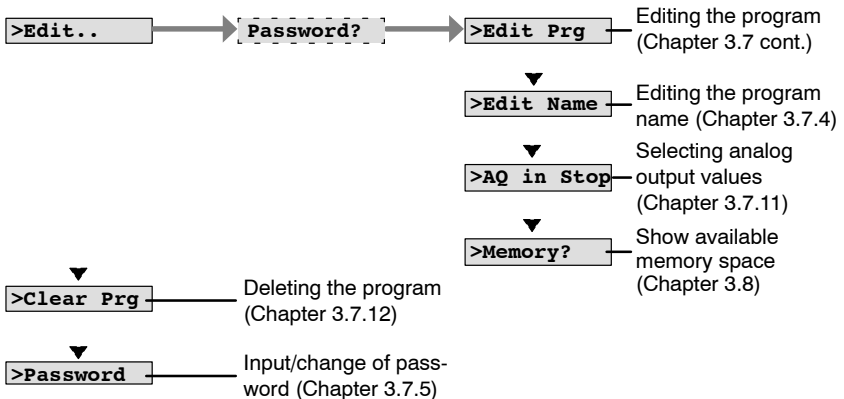

Transfer menu (ESC / >Stop → >Card)

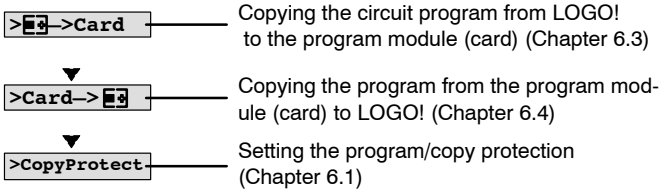

Setup menu (ESC / >Stop → >Setup)

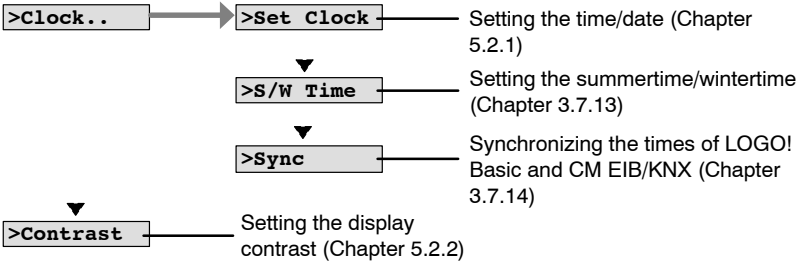

Start menu (RUN)

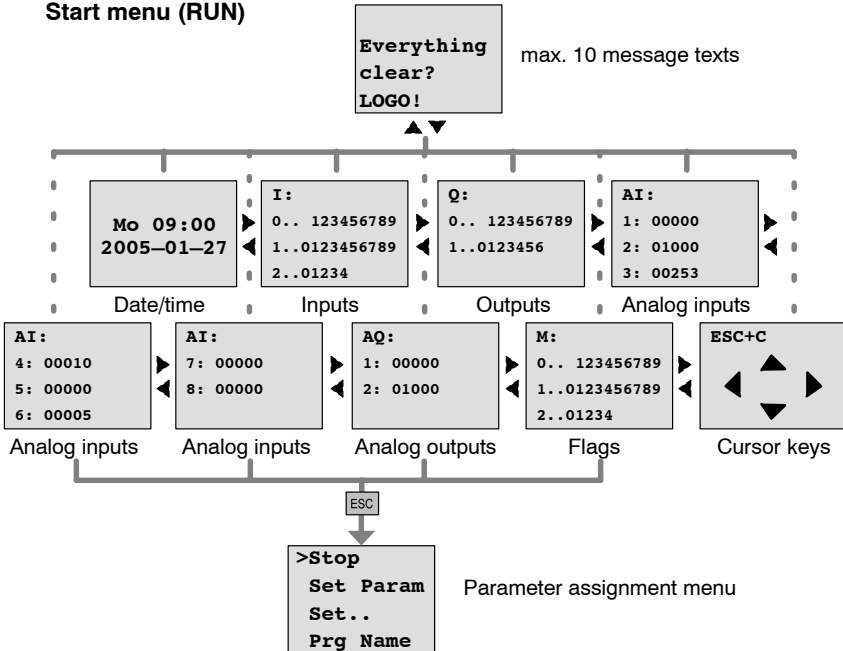

E Order numbers

Table A

Variant	Designation	Order number
Basic	LOGO! 12/24 RC *	6ED1052-1MD00-0BA5
	LOGO! 24 *	6ED1052-1CC00-0BA5
	LOGO! 24 RC (AC)	6ED1052-1HB00-0BA5
	LOGO! 230 RC	6ED1052-1FB00-0BA5
Basic without display (pure)	LOGO! 12/24 RC ₀ *	6ED1052-2MD00-0BA5
	LOGO! 24 ₀ *	6ED1052-2CC00-0BA5
	LOGO! 24 RC ₀ (AC)	6ED1052-2HB00-0BA5
	LOGO! 230 RC ₀	6ED1052-2FB00-0BA5
Digital modules	LOGO! DM 8 12/24R	6ED1055-1MB00-0BA1
	LOGO! DM 8 24	6ED1055-1CB00-0BA0
	LOGO! DM 8 24R	6ED1055-1HB00-0BA0
	LOGO! DM 8 230R	6ED1055-1FB00-0BA1
	LOGO! DM 16 24	6ED1055-1CB10-0BA0
	LOGO! DM 16 24R	6ED1055-1NB10-0BA0
	LOGO! DM 16 230R	6ED1055-1FB10-0BA0
Analog modules	LOGO! AM 2	6ED1055-1MA00-0BA0
	LOGO! AM 2 PT100	6ED1055-1MD00-0BA0
	LOGO! AM 2 AQ	6ED1055-1MM00-0BA0
Communication modules	CM EIB/KNX	6BK1700-0BA00-0AA1
	CM AS Interface	3RK1400-0CE10-0AA2

*: Also with analog inputs

Table B

Accessories	Designation	Order number
Software	LOGO!Soft Comfort V5.0	6ED1058-0BA01-0YA0
	Upgrade to LOGO!Soft Comfort V5.0	6ED1058-0CA01-0YE0
Program mod- ule (card)	LOGO! Card	6ED1056-5CA00-0BA0
Switching mod- ules	LOGO!Contact 24 V	6ED1057-4CA00-0AA0
	LOGO!Contact 230 V	6ED1057-4EA00-0AA0
Power modules	LOGO!Power 12V/1.9A	6EP1321-1SH02
	LOGO!Power 12V/4.5A	6EP1322-1SH02
	LOGO!Power 24V/1.3A	6EP1331-1SH02
	LOGO!Power 24V/2.5A	6EP1332-1SH42
	LOGO!Power 24V/4A	6EP1332-1SH51
	LOGO!Power 5V/3A	6EP1311-1SH02
	LOGO!Power 5V/6.3A	6EP1311-1SH12
	LOGO!Power 15V/1.9A	6EP1351-1SH02
Others	PC cable	6ED1057-1AA00-0BA0
	Manual	6ED1050-1AA00-0BE6

F Abbreviations

AM	Analog module
B1	Block number B1
BN	Block Number
C	LOGO! device designation: integrated clock
CM	Communication Module
Cnt	Count = Counter input
Co	Connector
Dir	Direction (of count, for example)
DM	Digital Module
EIB	European Installation Bus
EIS	EIB Interoperability Standard
En	Enable = switching on (e.g. clock generators)
ETS	EIB Tool Software
Fre	Input for frequency signals to be analyzed
GF	Basic Functions
Inv	Input for inverting the output signal
KNX	Konnex Association Standard for home and building electronic systems
No	Cam (parameter of the timer)
o	in LOGO! designations: without display
Par	Parameter
R	Reset input
R	in LOGO! designations: Relay outputs
Ral	Reset all = Input for resetting all internal values
S	Set (latching relay, for example)
SF	Special functions
SU	Subunit
T	Time = parameter
Trg	Trigger (parameter)

0BA5 devices: the latest LOGO! Basic version, described in this manual.

Index

A

- Abbreviations, 313
- AM. *See* Analog module
- Amplifier, analog, 196
- Analog
 - comparator, 188
 - values, 129
- Analog amplifier, 196
- Analog differential trigger, 184
- Analog module, 2, 9
- Analog multiplexer, 216
- Analog output values, 96
- Analog outputs, 42
- Analog ramp, 220
- Analog threshold trigger, 181
- Analog value monitoring, 193
- AND, 117
- Applications, 263
- AQ in Stop, 96
- AS interface, 3
- AS interface bus
 - communication failure, 51
 - communication states, 51
 - connecting, 43
 - networking, 44
- Asynchronous pulse generator, 151

B

- Basic functions, 115
 - AND, 117
 - with edge, 118
 - NAND, 119
 - with edge, 120
 - NOR, 122
 - NOT, 123
 - OR, 121
 - XOR, 123
- Basics on special functions, 124
- BF, 111
- Blank outputs, 56
- blank outputs, 113
- Block, 60
 - deleting, 93
 - block groups, 94
 - inserting, 88
 - number, 60
 - assigning, 61
- BN, 111

C

- Cap, 24
- Card. *See* Program module (card)
- CE label, 13

- Certification, 12
- Character set, 79
- Circuit diagram, 63
- Circuit program, input, 72
- circuit program, 106
 - deleting, 97
- Circuit program name, assigning, 78
- Circuit programs
 - archiving, 245
 - reproduce, 245
 - send by mail, 245
- Closing the programming mode, 93
- CM. *See* Communications module
- Co, 111, 112
- Communication module
 - AS interface, 3
 - EIB/KNX, 3
- Communication modules, 3
- Communications module, AS interface, 9
- Compatibility, Versions, 246
- Compatibility, Expansion modules, 22
- Configuring, EIB bus, 58
- Connecting
 - AS interface bus, 43
 - EIB bus, 42
 - Inputs, 32
 - outputs, 40
- Connector, 24
- Connectors, 55, 112
 - blank, 56
 - hi, 57
 - inputs, 57
 - lo, 57
 - LOGO!'s, 56
 - open, 114
 - outputs, 57
 - unused, 64
 - x, 56, 57, 64, 125
- Constants, 112
- Control panel, 5, 6
- Conversion, Summertime and wintertime, 98
- Correcting typing errors, 95
- Counter
 - Operating hours, 173
 - Up/down, 169
- CSA, 12
- cULus , 12
- Cursor, 67
- Cursor keys, 56, 114, 207
- Cursor movement, 67
- Cycle time, 303

D

- Default values, 241
- Demo versions, 259
- Device types, LOGO!, 2
- Digital module, 2, 9
- Dimensions, 23
- DIN rail, 23
- Display, 61

Display contrast, 243
Display view, 61
Disposal, 13
DM8.... See Digital module

E

Earth connection, 31
Edge evaluation, 118, 120
Editing, 88
EIB bus
 communication failure, 52
 communication states, 51
 configuring, 58
 connecting, 42
 networking, 43
EIB/KNX, 3
exclusive OR, 123
Expansion modules, 2
 Analog module, 2, 57
 Digital module, 57
 digital module, 2
 Operating state, 50
expansion modules, 55

F

Flag blocks, 113
FM, 12
Four golden rules, 66
Function blocks, 60
Functions, 111

G

Gain, 129
GF, 115
Golden rules, 66
Guidelines, 15

H

Hiding, 91
high-speed counting, 35
Hours counter, 173
 Reading the MN and OT values, 176
Hysteresis, 192

I

Inputs, 112
 Analog inputs, 35, 112
 connection, 32
 Cursor keys, 56, 114
 Digital Inputs, 112
 Groups, 33
 inverting, 77, 115, 132
 unused, 64
inputs, High-speed inputs, 35
Inserting, 88
Installation guidelines, 15
Interlock, 25, 27
Internet address, ii
Interpulse, width, 152

Inverter, 123

L

Labeling, 29

Latching relay, 198

LCD, 5, 6

LED, 307

Levels, 114

List

BF, 111

BN, 111

Co, 111, 112

SF, 111, 132

List , GF, 115

Logic module, 1

Logical inputs, 125

LOGO!

connecting to PC, 260

Guidelines, 15

identifying, 9

Installing, 23

labeling, 29

Operating states, 49

removing, 23

Structure of, 5

switching on, 46

Versions, 10

wiring, 30

LOGO! menus, 68

LOGO! software, 257

LOGO!Soft Comfort, 258

M

Memory

areas, 106

free, 110

limitation, 106

requirements, 107

space, 106

Menu structure, 309

Menus

Main menu, 68

Parameter assignment menu,
68

Programming menu, 68

Setup menu, 68

Transfer menu, 68

Message texts, 202

Character set, 207

Mode

Parameter assignment, 234

parameter assignment, 68

PC-LOGO, 260

programming, 68

Mounting

DIN rail mounting, 24

Drilling template, 29

Wall-mounting, 28

Multiple function switch, 158

N

Name, 78

NAND, 119

Negation, 123
 of a BF input, 115
 of an input, 77
 of an SF input, 132

Networking
 AS interface bus, 44
 EIB bus, 43

NOR , 122

NOT , 123

NOT AND, 119

NOT OR, 122

O

Off-delay, 140

Off-time, 163

Offset, 129

On-/Off-delay, 142

On-delay, 136
 retentive, 144

On-time, 163

Open connectors, 114

Operating
 characteristics, 306
 Status indication, 307

Operating mode
 Changing the operating
 mode, 66
 Programming mode, 69

OR, 121

Order numbers, 311

Outputs, 112
 Analog outputs, 113

blank, 56, 113
 connecting, 40
 Digital outputs, 112

P

Parameter, 236
 'Set Param', 235
 Inputs, 126
 selecting, 237
 setting, 233
 T, 126

Parameter assignment, 90

Parameter assignment menu,
 234

Parameter assignment screen
 form, 162, 204

Parameter protection, 128

Parameters, modifying, 238

parameters, showing/hiding, 91

Password
 assigning, 79
 changing, 81
 deactivating, 82
 wrong, 83

PC cable, 260
 USB, 260

PC-LOGO, 260

PI controller, 225

Planning, 67

Power
 off, 47
 On, 46
 on, 47

- switch, 46
- Power supply, connecting, 30
- Program memory, 106
- Program chart, 62
- Program cycle, 303
- Program module (card)
 - 'Card --> LOGO', 255
 - 'CopyProtect', 248
 - 'LOGO --> Card', 252
 - copying, 254
 - Enabling the security function, 249
 - inserting, 250, 251
 - removing, 250, 251
 - Security function, 247
- Program name
 - change, 79
 - character set, 79
 - read, 235
- Programs
 - 'AQ in Stop', 96
 - 'Clear Prg', 97
 - 'Edit Name', 78
 - 'Edit Prg', 70
 - 'Password', 80
 - modifying, 87
- Protection mode, 91
- Pulse
 - Pause, 149
 - width, 149
 - width , 152
- pulse generator, Asynchronous , 151
- Pulse output, 146
- Pulse relay, 199

R

- Random generator, 153
- Recycling, 13
- Relay outputs, 40, 291
 - service life, 291
 - switching capacity, 291
- Removal, 26
- Resources, 106
- Retentive memory, 106
- Retentive on-delay, 144
- Retentivity, 128
 - enabling/disabling, Retentivity setting, 91
- Rules, Four golden, 66
- RUN, 'Start', 84

S

- Sensor Characteristics, 32
- Sensor connections, 36
- Set clock, 'Set Clock', 242
- Setting
 - Default values, 241
 - Display contrast, 243
 - Start screen, 244
 - time, 91
 - Time-of-day and date, 241
- Setting the date, 241
- Setting the time-of-day, 241
- Settings, 'Set', 235

- Setup, 19
 - Maximum setup, 19
 - with different voltage classes, 20
- SF, 111, 132
- SFs, Delay, On, 136
- Shift register, 213
- Shift register bits, 56, 114
- Showing, 91
- Signal status transitions, 34
- Simulation, 257
- Size of a circuit, 106
- Softkey, 209
- Software, 257
- Solid-state outputs, 41
- Special functions, 132
 - Analog amplifier, 196
 - Analog Comparator, 188
 - Analog differential trigger, 184
 - Analog multiplexer, 216
 - Analog ramp, 220
 - Analog threshold trigger, 181
 - Analog value monitoring, 193
 - Basics, 124
 - Counter
 - Hours counter, 173
 - Up/down, 169
 - Delay
 - Off, 140
 - On/Off, 142
 - delay, ret. on, 144
 - Message texts, 202
 - PI controller, 225
 - Pulse generator, asynchronous, 151
 - Random generator, 153
 - Relay, Latch, 198
 - relay, Pulse, 199
 - Shift register, 213
 - Softkey, 209
 - Switch
 - Comfort, 158
 - Stairway lighting, 155
 - Threshold trigger, Frequency, 178
 - Timer
 - Week, 161
 - Year, 166
 - Trigger, Analog threshold, 181
 - Wiping relay
 - edge triggered, 148
 - Pulse output, 146
- Stairway lighting switch, 155
- Start, 84
- Start screen, 244
- Startup characteristics, 306
- Startup flag, 114
- Stop, 235
- Subunits, 23
- Summertime, 98
- Summertime/Wintertime Conversion
 - 'Clock', 99
 - 'S/W Time', 99
- Summertime/wintertime conversion, 98, 241
 - disabling, 103
 - enabling, 99
 - user-define parameters, 101
- Switch
 - Multiple function, 158

Stairway lighting, 155
Switched current, maximum, 41
Symbols, 9
Synchronization, 103, 241
 'Clock', 104
 'Sync', 104
 enabling, 104

T

T, Parameter, 127
Technical data, 267
 CM EIB/KNX, 296
 general, 267
 LOGO! 12..., 288
 LOGO! 230..., 270
 LOGO! 24/24o, 276
 LOGO! 24RC/24RCo, 282
 LOGO! AM 2 PT100, 293
 LOGO! AM2, 292
 LOGO! AM2 AQ, 295
 LOGO! DM16 230R, 273
 LOGO! DM16 24, 279
 LOGO! DM16 24R, 285
 LOGO! DM8 12/24R, 288
 LOGO! DM8 230R, 273
 LOGO! DM8 24, 279
 LOGO! DM8 24R, 285
 LOGO!Contact, 302
 LOGO!Power 12 V, 298
Threshold trigger, Frequencies, 178
Time, Accuracy of, 126
Time response, 126
Timebase, 90, 126, 137
Timer, 1

accuracy, 127
Timing inaccuracy , 127
Trigger, Analog threshold, 181
trigger, Analog, Differential, 184

U

Unused connectors, 64
unused connectors, 56
Unused inputs, 64
Up/down counter, 169
Update, 259
Upward compatibility, 246
URL, ii
USB, 260

V

Verification, 92
Voltage levels , 114
Voltage supply, connecting, Circuit protection, 32

W

Weekday, 162
Weekly timer, 9, 163
 Examples, 164
 setting, 163
Weekly timer , 161
Wintertime, 98

Wiping relay
edge triggered, 148
Pulse output, 146

Wire ferrules, 30

without display, 305
creating a circuit program, 53
PC-LOGO mode, 260
reading current data, 307

X

XOR , 123

Y

Yearly timer, 166

Z

Zero offset, 129

