

5

4

3

2

1

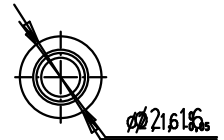
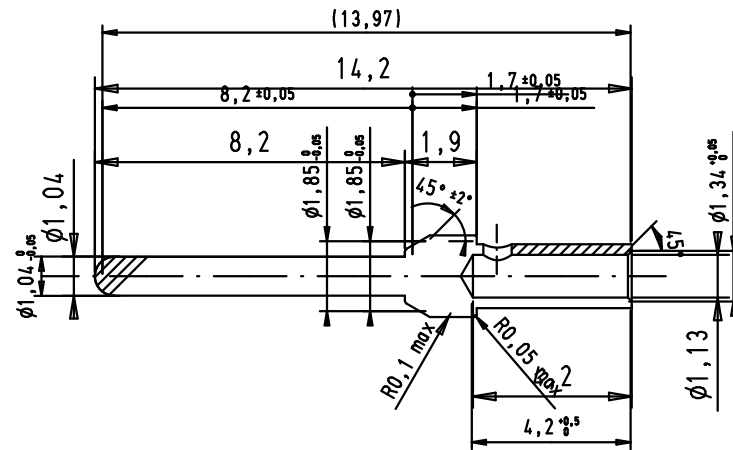

Crimping of AWG 20-24 : hand tool 09 99 000 0501
and locator 09 99 000 0531

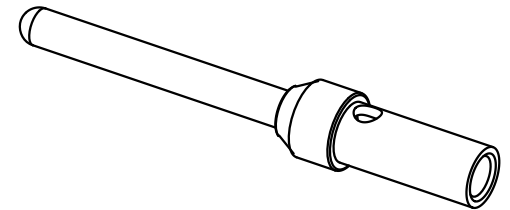
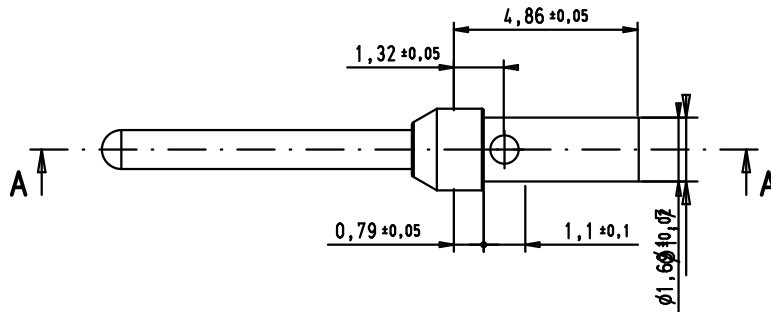

A

5000	09 67 000 8576 580	PL1
100	09 67 000 8576	PL1
Bulk packaging	Part number	Gold plating (over nickel)

EC04018	07/11/11	SD
EC01739	29apr2010	LP
EC01656	12apr2010	LP
Mod.	Dat.	Name

	Det.	Name
Detail.	12apr2010	LP
Insp.	07/11/11	JB
Stand.		
HARTING EURL F-95972 Paris		

All Dim. in mm
Orig. Size DIN A 4

D-Sub	AWG 20-24
male turned crimp contact	
TB09 67 000 857x	
Sub.	

Maßstab/ Scale	5/1
Blatt/ Page	1/1