



KS8993M/ML/MI

Integrated 3-Port 10/100 Managed Switch with PHYs

Rev 1.04

General Description

The KS8993M, a highly integrated Layer 2 managed switch, is designed for low port count, cost-sensitive 10/100 Mbps switch systems. It offers an extensive feature set that includes tag/port-based VLAN, quality of service (QoS) priority, management, management information base (MIB) counters, MII/SNI, and CPU control/data interfaces to effectively address both current and emerging Fast Ethernet applications.

The KS8993M contains two 10/100 transceivers with patented mixed-signal low-power technology, three media access control (MAC) units, a high-speed non-blocking switch fabric, a dedicated address lookup engine, and an on-chip frame buffer memory.

Both PHY units support 10BASE-T and 100BASE-TX. In addition, one of the PHY unit supports 100BASE-FX.

The KS8993ML is the single supply version with all the identical rich features of the KS8993M.

Functional Diagram

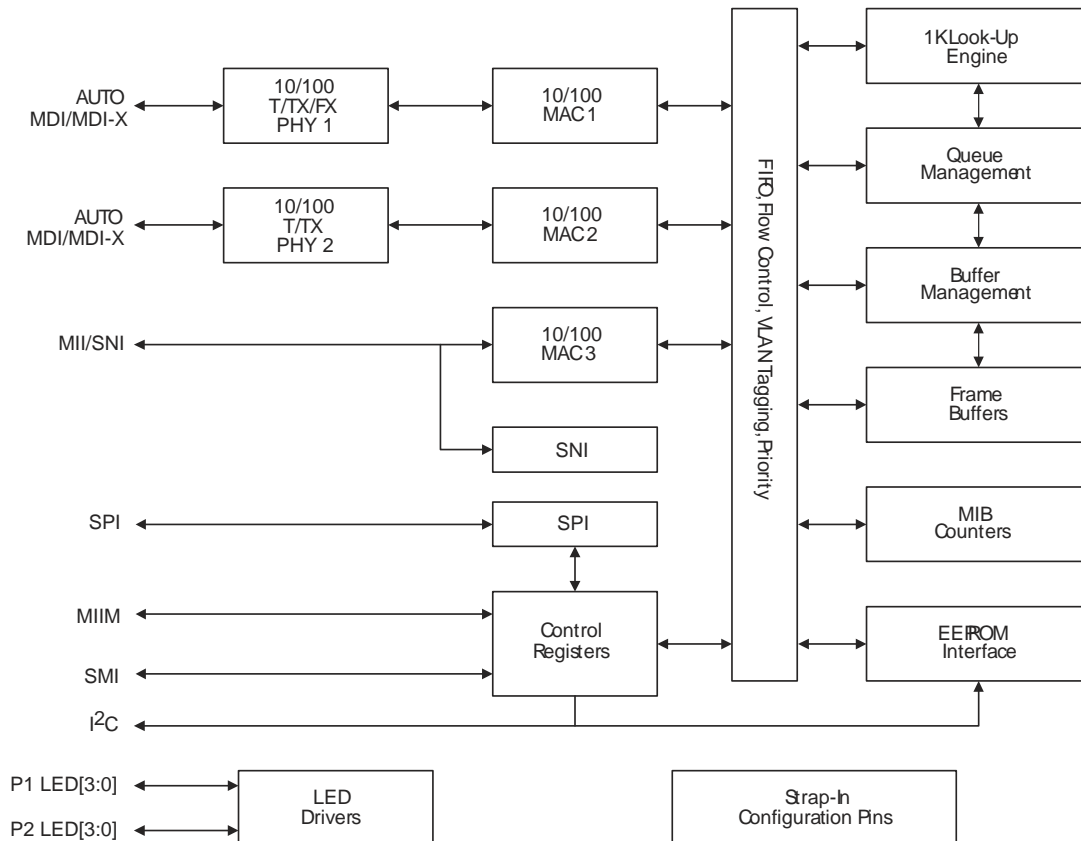

Features

- **Proven Integrated 3-Port 10/100 Ethernet Switch**
 - 2nd generation switch with three MACs and two PHYs fully compliant to IEEE 802.3u standard
 - Non-blocking switch fabric assures fast packet delivery by utilizing a 1K MAC address lookup table and a store-and-forward architecture
 - Full duplex IEEE 802.3x flow control (pause) with force mode option
 - Half-duplex back pressure flow control
 - Automatic MDI/MDI-X crossover with disable and enable option
 - 100BASE-FX support on port 1
 - MII interface supports both MAC mode and PHY mode
 - 7-wire serial network interface (SNI) support for legacy MAC
 - Comprehensive LED Indicator support for link, activity, full/half duplex and 10/100 speed
- **Comprehensive Configuration Register Access**
 - Serial management interface (SMI) to all internal registers
 - MII management (MIIM) interface to PHY registers
 - SPI and I²C Interface to all internal registers
 - I/O Pins strapping and EEPROM to program selective registers in unmanaged switch mode
 - Control registers configurable on the fly (port-priority, 802.1p/d/q, AN...)
- **QoS/CoS Packet Prioritization Support**
 - Per port, 802.1p and DiffServ-based
 - Re-mapping of 802.1p priority field per port basis
- **Advanced Switch Features**
 - IEEE 802.1q VLAN support for up to 16 groups (full-range of VLAN ID)
 - VLAN ID tag/untag options, per port basis
 - IEEE 802.1p/q tag insertion or removal on a per port basis (egress)
 - Programmable rate limiting from 0Mbps to 100Mbps at the ingress and egress port, rate options for high and low priority per port basis
 - Broadcast storm protection with % control (global and per port basis)
 - IEEE 802.1d spanning tree protocol support
 - Upstream special tagging mode to inform the processor which ingress port receives the packet
 - IGMP v1/v2 snooping support for multicast packet filtering
 - Double-tagging support

- **Switch Management Features**
 - Port mirroring/monitoring/sniffing: ingress and/or egress traffic to any port or MII
 - MIB counters for fully compliant statistics gathering, 34 MIB counters per port
 - Loopback modes for remote diagnostic of failure
- **Low Power Dissipation:** <0.8 Watts (includes PHY transmit drivers)
 - Full-chip hardware power-down (register configuration not saved)
 - Per port based software power-save on PHY (idle link detection, register configuration preserved)
 - 0.18um CMOS technology
 - Voltages: Core 1.8V
I/O and Transceiver 3.3V
Use K8993ML for 3.3V only operation
- Industrial Temperature Range: –40°C to +85°C
- Available in 128-Pin PQFP

Applications

- **Universal Solutions**
 - Broadband gateway / Firewall / VPN
 - Integrated DSL or cable modem multi-port router
 - Wireless LAN access point + gateway
 - Residential and enterprise VoIP gateway/phone
 - Set-top/game box
 - Home networking expansion
 - Standalone 10/100 switch
 - FTTx customer premises equipment
 - Fiber broadband gateway
- **Upgradeable Solutions⁽¹⁾**
 - Unmanaged switch with future option to migrate to a managed solution
 - Single PHY alternative with future expansion option for two ports
- **Industrial Solutions**
 - Applications requiring port redundancy and port monitoring
 - Sensor devices in redundant ring topology

Note:

1. The cost and time of PCB re-spin.

Ordering Information

Part Number	Temperature Range	Package
KS8993M	0°C to 70°C	128-Pin PQFP
KS8993ML	0°C to 70°C	128-Pin PQFP
KS8993MI	-40°C to +85°C	128-Pin PQFP
KSZ8993M	0°C to 70°C	128-Pin PQFP, Lead-free
KSZ8993ML	0°C to 70°C	128-Pin PQFP, Lead-free

Revision History

Revision	Date	Summary of Changes
1.00	5/14/03	Created.
1.01	5/28/03	Added KS8993MI availability in Q4 2003.
1.02	12/8/03	<p>Changed V_{DDIO}, V_{DDATX} and V_{DDARX} supply voltages from 3.3V to (3.3V or 2.5V).</p> <p>Changed [PS1,PS0] = [1,1] setting from Reserved to SMI mode.</p> <p>Changed Special Tagging Mode to Upstream Special Tagging Mode (Switch port 3 to processor support only).</p> <p>Updated recommended magnetic manufacturer list.</p> <p>Added 25MHz crystal/oscillator clock's ppm spec. in Pin Description.</p> <p>Updated I²C Slave Serial Bus Configuration section.</p> <p>Updated KS8993MI availability to from Q1 2004.</p>
1.03	9/22/04	<p>Added KS8993ML to General Description (page 1) and to the Functional Description.</p> <p>Updated Part Ordering Information table.</p> <p>Updated pin description for pin 22 to the following:</p> <p>V_{DDC}: For KS8993M, this is an input power pin for the 1.8V digital core V_{DD}.</p> <p>V_{OUT_1V8}: For KS8993ML, this is an 1.8V output power pin to supply the KS8993ML's input power pins: V_{DDAP} (pin 63), V_{DDC} (pins 91, 123), and V_{DDA} (pins 38, 43, 57).</p> <p>Updated pin description for P1LED3 (pin 25) to indicate that an external 1K pull-down is needed if a LED is connected.</p> <p>Updated pin description for MDIO (pin 95) to indicate that an external 4.7K pull-up is needed if this pin is in used.</p> <p>Changed the aging period from 300 +/-75 seconds to about 200 seconds.</p> <p>Updated Electrical Characteristics (V_{IH}, V_{IL}, V_{OH}, V_{OL}).</p> <p>Transferred to new format.</p>
1.04	4/12/05	<p>Removed references to 2.5V operation</p> <p>Added reset circuit recommendation</p>

Contents

List of Figures 8

List of Tables 8

Pin Description and I/O Assignment 9

Pin Configuration 19

Functional Description 20

Functional Overview: Physical Layer Transceiver 20

 100BASE-TX Transmit 20

 100BASE-TX Receive 20

 PLL Clock Synthesizer 21

 Scrambler/De-scrambler (100BASE-TX Only) 21

 100BASE-FX Operation 21

 100BASE-FX Signal Detection 21

 100BASE-FX Far End Fault 21

 10BASE-T Transmit 21

 10BASE-T Receive 22

 Power Management 22

 MDI /MDI-X Auto Crossover 22

Straight Cable 23

Crossover Cable 24

 Auto Negotiation 24

Functional Overview: MAC and Switch 26

 Address Lookup 26

 Learning 26

 Migration 26

 Aging 26

 Forwarding 26

 Switching Engine 29

 MAC Operation 29

Inter Packet Gap (IPG) 29

Back-Off Algorithm 29

Late Collision 29

Illegal Frames 29

Flow Control 29

Half-Duplex Backpressure 29

Broadcast Storm Protection 30

 MII Interface Operation 30

 SNI (7-Wire) Operation 31

 MII Management Interface (MIIM) 31

 Serial Management Interface (SMI) 32

Advanced Switch Functions 33

 Spanning Tree Support 33

 Upstream Special Tagging Mode 34

 IGMP Support 35

"IGMP" Snooping 35

"Multicast Address Insertion" in the Static MAC Table 35

 Port Mirroring Support 35

 IEEE 802.1Q VLAN Support 35

 QoS Priority Support 36

 Rate Limiting Support 38

 Configuration Interface 38

I²C Master Serial Bus Configuration 38

I²C Slave Serial Bus Configuration 39

SPI Slave Serial Bus Configuration 39

 Loopback Support 43

MII Management (MIIM) Registers 44

 Register 0: MII Basic Control 45

Register 1: MII Basic Status	45
Register 2: PHYID HIGH	45
Register 3: PHYID LOW	45
Register 4: Auto-Negotiation Advertisement Ability	46
Register 5: Auto-Negotiation Link Partner Ability	46
Register Map: Switch & PHY (8 bit registers).....	47
Global Registers.....	47
Port Registers	47
Advanced Control Registers.....	47
Global Registers.....	47
Register 0 (0x00): Chip ID0.....	47
Register 1 (0x01): Chip ID1 / Start Switch.....	48
Register 2 (0x02): Global Control 0.....	48
Register 3 (0x03): Global Control 1.....	49
Register 4 (0x04): Global Control 2.....	49
Register 5 (0x05): Global Control 3.....	50
Register 6 (0x06): Global Control 4.....	51
Register 7 (0x07): Global Control 5.....	52
Register 8 (0x08): Global Control 6.....	52
Register 9 (0x09): Global Control 7.....	52
Register 10 (0x0A): Global Control 8.....	52
Register 11 (0x0B): Global Control 9.....	52
Register 12 (0x0C): Reserved Register.....	53
Register 13 (0x0D): User Defined Register 1	53
Register 14 (0x0E): User Defined Register 2	53
Register 15 (0x0F): User Defined Register 3	53
Port Registers.....	54
Register 16 (0x10): Port 1 Control 0.....	54
Register 32 (0x20): Port 2 Control 0.....	54
Register 48 (0x30): Port 3 Control 0.....	54
Register 17 (0x11): Port 1 Control 1.....	55
Register 33 (0x21): Port 2 Control 1.....	55
Register 49 (0x31): Port 3 Control 1.....	55
Register 18 (0x12): Port 1 Control 2.....	56
Register 34 (0x22): Port 2 Control 2.....	56
Register 50 (0x32): Port 3 Control 2.....	56
Register 19 (0x13): Port 1 Control 3.....	56
Register 35 (0x23): Port 2 Control 3.....	56
Register 51 (0x33): Port 3 Control 3.....	56
Register 20 (0x14): Port 1 Control 4.....	57
Register 36 (0x24): Port 2 Control 4.....	57
Register 52 (0x34): Port 3 Control 4.....	57
Register 21 (0x15): Port 1 Control 5.....	57
Register 37 (0x25): Port 2 Control 5.....	57
Register 53 (0x35): Port 3 Control 5.....	57
Register 22 (0x16): Port 1 Control 6.....	57
Register 38 (0x26): Port 2 Control 6.....	57
Register 54 (0x36): Port 3 Control 6.....	57
Register 23 (0x17): Port 1 Control 7.....	57
Register 39 (0x27): Port 2 Control 7.....	57
Register 55 (0x37): Port 3 Control 7.....	57
Register 24 (0x18): Port 1 Control 8.....	57
Register 40 (0x28): Port 2 Control 8.....	57
Register 56 (0x38): Port 3 Control 8.....	57
Register 25 (0x19): Port 1 Control 9.....	58
Register 41 (0x29): Port 2 Control 9.....	58
Register 57 (0x39): Port 3 Control 9.....	58
Register 26 (0x1A): Port 1 Control 10	58
Register 42 (0x2A): Port 2 Control 10	58
Register 58 (0x3A): Port 3 Control 10	58
Register 27 (0x1B): Port 1 Control 11	58
Register 43 (0x2B): Port 2 Control 11	58

Register 59 (0x3B): Port 3 Control 11	58
Register 28 (0x1C): Port 1 Control 12	59
Register 44 (0x2C): Port 2 Control 12	59
Register 60 (0x3C): Reserved, not applied to port 3	59
Register 29 (0x1D): Port 1 Control 13	60
Register 45 (0x2D): Port 2 Control 13	60
Register 61 (0x3D): Reserved, not applied to port 3	60
Register 30 (0x1E): Port 1 Status 0	61
Register 46 (0x2E): Port 2 Status 0	61
Register 62 (0x3E): Reserved, not applied to port 3	61
Register 31 (0x1F): Port 1 Status 1	62
Register 47 (0x2F): Port 2 Status 1	62
Register 63 (0x3F): Port 3 Status 1	62
Advanced Control Registers	63
Register 96 (0x60): TOS Priority Control Register 0	63
Register 97 (0x61): TOS Priority Control Register 1	63
Register 98 (0x62): TOS Priority Control Register 2	63
Register 99 (0x63): TOS Priority Control Register 3	63
Register 100 (0x64): TOS Priority Control Register 4	63
Register 101 (0x65): TOS Priority Control Register 5	63
Register 102 (0x66): TOS Priority Control Register 6	63
Register 103 (0x67): TOS Priority Control Register 7	63
Register 104 (0x68): MAC Address Register 0	64
Register 105 (0x69): MAC Address Register 1	64
Register 106 (0x6A): MAC Address Register 2	64
Register 107 (0x6B): MAC Address Register 3	64
Register 108 (0x6C): MAC Address Register 4	64
Register 109 (0x6D): MAC Address Register 5	64
Register 110 (0x6E): Indirect Access Control 0	65
Register 111 (0x6F): Indirect Access Control 1	65
Register 112 (0x70): Indirect Data Register 8	65
Register 113 (0x71): Indirect Data Register 7	65
Register 114 (0x72): Indirect Data Register 6	65
Register 115 (0x73): Indirect Data Register 5	65
Register 116 (0x74): Indirect Data Register 4	65
Register 117 (0x75): Indirect Data Register 3	66
Register 118 (0x76): Indirect Data Register 2	66
Register 119 (0x77): Indirect Data Register 1	66
Register 120 (0x78): Indirect Data Register 0	66
Registers 121 to 127	66
Static MAC Address Table	66
VLAN Table	67
Dynamic MAC Address Table	68
MIB (Management Information Base) Counters	69
Additional Information	72
Absolute Maximum Ratings	73
Operating Ratings	73
Electrical Characteristics	74
Timing Specifications	76
EEPROM Timing	76
SNI Timing	77
MII Timing	77
MAC Mode MII Timing	78
PHY-Mode MII Timing	79
SPI Timing	77
Input Timing	80
Output Timing	81
Reset Timing	82
Selection of Isolation Transformers	84
Selection of Reference Crystal	84
Package Information	85

List of Figures

Figure 1. Typical Straight Cable Connection	24
Figure 2. Typical Crossover Cable Connection	24
Figure 3. Auto Negotiation and Parallel Operation	25
Figure 4. Destination Address Lookup Flow Chart, Stage 1	27
Figure 5. Destination Address Resolution Flow Chart, Stage 2	28
Figure 6. 802.1p Priority Field Format	37
Figure 7. KS8993M EEPROM Configuration Timing Diagram	38
Figure 8. SPI Write Data Cycle.....	41
Figure 9. SPI Read Data Cycle	41
Figure 10. SPI Multiple Write.....	41
Figure 11. SPI Multiple Read.....	42
Figure 12. Loopback Path	43
Figure 13. EEPROM Interface Input Timing Diagram	76
Figure 14. EEPROM Interface Output Timing Diagram	76
Figure 15. SNI Input Timing Diagram.....	77
Figure 16. SNI Output Timing Diagram.....	77
Figure 17. MAC-Mode MII Timing – Data Received from MII	78
Figure 18. MAC-Mode MII Timing – Data Input to MII	78
Figure 19. PHY-Mode MII Timing – Data Received from MII	79
Figure 20. PHY-Mode MII Timing – Data Input to MII	79
Figure 21. SPI Input Timing.....	80
Figure 22. SPI Output Timing.....	81
Figure 23. Reset Timing	82
128-Pin PQFP Package.....	85

List of Tables

Table 1. FX and TX Mode Selection	21
Table 2. MDI/MDI-X Pin Definitions.....	22
Table 3. MII Signals.....	30
Table 4. SNI Signals.....	31
Table 5. MII Management Interface Frame Format	32
Table 6. Serial Management Interface (SMI) Frame Format.....	32
Table 7. Upstream Special Tagging Mode Format	34
Table 8. STPID Egress Rules (Switch Port 3 to Processor).....	34
Table 9. FID+DA Lookup in VLAN Mode.....	36
Table 10. FID+SA Lookup in VLAN Mode	36
Table 11. KS8993M SPI Connections.....	40
Table 12. Format of Static MAC Table (8 Entries).....	66
Table 13. Format of Static VLAN Table (16 Entries).....	68
Table 14. Format of Dynamic MAC Address Table (1K Entries)	68
Table 15. Format of “Per Port” MIB Counters.....	69
Table 16. Port 1s “Per Port” MIB Counters Indirect Memory Offsets.....	70
Table 17. Port 1’s “Per Port” MIB Counters Indirect Memory Offsets.....	71
Table 18. Format of “All Port Dropped Packet” MIB Counters	71
Table 19. “All Port Dropped Packet” MIB Counters Indirect Memory Offsets	71
Table 20. EEPROM Timing Parameters	76
Table 21. SNI Timing Parameters	77
Table 22. MAC-Mode MII Timing Parameters	78
Table 23. PHY-Mode MII Timing Parameters	79
Table 24. SPI Input Timing Parameters	80
Table 25. SPI Output Timing Parameters	81
Table 26. Reset Timing Parameters	82
Table 27. Transformer Selection Criteria.....	84
Table 28. Qualified Single Port Magnetics	84
Table 29. Typical Reference Crystal Characteristics	84

Pin Description and I/O Assignment

Pin Number	Pin Name	Type ⁽¹⁾	Description																																				
1	P1LED2	Ipu/O	Port 1 LED indicators <table border="1"> <tr> <td colspan="3">[LEDSEL1, LEDSEL0]</td> </tr> <tr> <td></td> <td>[0, 0]</td> <td>[0, 1]</td> </tr> <tr> <td>P1LED3</td> <td>—</td> <td>—</td> </tr> <tr> <td>P1LED2</td> <td>Link/Act</td> <td>100Link/Act</td> </tr> <tr> <td>P1LED1</td> <td>Full duplex/Col</td> <td>10Link/Act</td> </tr> <tr> <td>P1LED0</td> <td>Speed</td> <td>Full duplex</td> </tr> </table> <table border="1"> <tr> <td colspan="3">[LEDSEL1, LEDSEL0]</td> </tr> <tr> <td></td> <td>[1, 0]</td> <td>[1, 1]</td> </tr> <tr> <td>P1LED3</td> <td>Act</td> <td>—</td> </tr> <tr> <td>P1LED2</td> <td>Link</td> <td>—</td> </tr> <tr> <td>P1LED1</td> <td>Full duplex/Col</td> <td>—</td> </tr> <tr> <td>P1LED0</td> <td>Speed</td> <td>—</td> </tr> </table> <p>Notes: LEDSEL0 is external strap-in pin 70. LEDSEL1 is external strap-in pin 23. P1LED3 is pin 25. During reset, P1LED[2:0] are inputs for internal testing.</p>	[LEDSEL1, LEDSEL0]				[0, 0]	[0, 1]	P1LED3	—	—	P1LED2	Link/Act	100Link/Act	P1LED1	Full duplex/Col	10Link/Act	P1LED0	Speed	Full duplex	[LEDSEL1, LEDSEL0]				[1, 0]	[1, 1]	P1LED3	Act	—	P1LED2	Link	—	P1LED1	Full duplex/Col	—	P1LED0	Speed	—
[LEDSEL1, LEDSEL0]																																							
	[0, 0]	[0, 1]																																					
P1LED3	—	—																																					
P1LED2	Link/Act	100Link/Act																																					
P1LED1	Full duplex/Col	10Link/Act																																					
P1LED0	Speed	Full duplex																																					
[LEDSEL1, LEDSEL0]																																							
	[1, 0]	[1, 1]																																					
P1LED3	Act	—																																					
P1LED2	Link	—																																					
P1LED1	Full duplex/Col	—																																					
P1LED0	Speed	—																																					
2	P1LED1	Ipu/O																																					
3	P1LED0	Ipu/O																																					
4	P2LED2	Ipu/O	Port 2 LED indicators <table border="1"> <tr> <td colspan="3">[LEDSEL1, LEDSEL0]</td> </tr> <tr> <td></td> <td>[0, 0]</td> <td>[0, 1]</td> </tr> <tr> <td>P2LED3</td> <td>—</td> <td>—</td> </tr> <tr> <td>P2LED2</td> <td>Link/Act</td> <td>100Link/Act</td> </tr> <tr> <td>P2LED1</td> <td>Full duplex/Col</td> <td>10Link/Act</td> </tr> <tr> <td>P2LED0</td> <td>Speed</td> <td>Full duplex</td> </tr> </table> <table border="1"> <tr> <td colspan="3">[LEDSEL1, LEDSEL0]</td> </tr> <tr> <td></td> <td>[1, 0]</td> <td>[1, 1]</td> </tr> <tr> <td>P2LED3</td> <td>Act</td> <td>—</td> </tr> <tr> <td>P2LED2</td> <td>Link</td> <td>—</td> </tr> <tr> <td>P2LED1</td> <td>Full duplex/Col</td> <td>—</td> </tr> <tr> <td>P2LED0</td> <td>Speed</td> <td>—</td> </tr> </table> <p>Notes: LEDSEL0 is external strap-in pin 70. LEDSEL1 is external strap-in pin 23. P2LED3 is pin 20. During reset, P2LED[2:0] are inputs for internal testing.</p>	[LEDSEL1, LEDSEL0]				[0, 0]	[0, 1]	P2LED3	—	—	P2LED2	Link/Act	100Link/Act	P2LED1	Full duplex/Col	10Link/Act	P2LED0	Speed	Full duplex	[LEDSEL1, LEDSEL0]				[1, 0]	[1, 1]	P2LED3	Act	—	P2LED2	Link	—	P2LED1	Full duplex/Col	—	P2LED0	Speed	—
[LEDSEL1, LEDSEL0]																																							
	[0, 0]	[0, 1]																																					
P2LED3	—	—																																					
P2LED2	Link/Act	100Link/Act																																					
P2LED1	Full duplex/Col	10Link/Act																																					
P2LED0	Speed	Full duplex																																					
[LEDSEL1, LEDSEL0]																																							
	[1, 0]	[1, 1]																																					
P2LED3	Act	—																																					
P2LED2	Link	—																																					
P2LED1	Full duplex/Col	—																																					
P2LED0	Speed	—																																					
5	P2LED1	Ipu/O																																					
6	P2LED0	Ipu/O																																					
7	DGND	Gnd	Digital ground																																				

Note:

- 1. Ipu/O = Input with internal pull-up during reset, output pin otherwise.
 Gnd = Ground.

Pin Number	Pin Name	Type ⁽¹⁾	Description
8	VDDIO	P	3.3V digital V _{DD}
9	NC	lpd	No connect
10	NC	lpd	No connect
11	NC	lpu	No connect
12	ADVFC	lpu	1 = advertise the switch's flow control capability via auto negotiation. 0 = will not advertise the switch's flow control capability via auto negotiation.
13	P2ANEN	lpu	1 = enable auto negotiation on port 2 0 = disable auto negotiation on port 2
14	P2SPD	lpd	1 = force port 2 to 100BT if P2ANEN = 0 0 = force port 2 to 10BT if P2ANEN = 0
15	P2DPX	lpd	1 = port 2 default to full duplex mode if P2ANEN = 1 and auto negotiation fails. Force port 2 in full duplex mode if P2ANEN = 0. 0 = port 2 default to half duplex mode if P2ANEN = 1 and auto negotiation fails. Force port 2 in half duplex mode if P2ANEN = 0.
16	P2FFC	lpd	1 = always enable (force) port 2 flow control feature 0 = port 2 flow control feature enable is determined by auto negotiation result.
17	NC	Opu	No connect
18	NC	lpd	No connect
19	NC	lpd	No connect
20	P2LED3	Opd	Port 2 LED indicator Note: Internal pull-down is weak; it will not turn ON the LED. See description in pin 4.
21	DGND	Gnd	Digital ground
22	VDDC/VOUT_1 V8	P	V _{DDC} : For KS8993M, this is an input power pin for the 1.8V digital core V _{DD} . V _{OUT_1V8} : For KS8993ML, this is a 1.8V output power pin to supply the KS8993ML's input power pins: V _{DDAP} (pin 63), V _{DDC} (pins 91 and 123), and V _{DDA} (pins 38, 43, and 57).
23	LEDSEL1	lpd	LED display mode select See description in pins 1 and 4.
24	NC	O	No connect
25	P1LED3	Opd	Port 1 LED indicator Note: An external 1K pull-down is needed on this pin if it is connected to a LED. The 1K resistor will not turn ON the LED. See description in pin 1.

Note:

1. P = Power supply.

Gnd = Ground.

O = Output.

lpu = Input w/ internal pull-up.

lpd = Input w/ internal pull-down.

Opu = Output with internal pull-up.

Opd = Output internal pull-down.

Pin Number	Pin Name	Type ⁽¹⁾	Description
26	NC	O	No connect
27	HWPOVR	lpd	Hardware pin overwrite 0 = Disable. All strap-in pins configurations are overwritten by the EEPROM configuration data 1 = Enable. All strap-in pins configurations are overwritten by the EEPROM configuration data, except for register 0x2C bits [7:5], (port 2: auto-negotiation enable, force speed, force duplex).
28	P2MDIXDIS	lpd	Port 2 Auto MDI/MDI-X PD (default) = enable PU = disable
29	P2MDIX	lpd	Port 2 MDI/MDI-X setting when auto MDI/MDI-X is disabled. PD (default) = MDI-X (transmit on TXP2 / TXM2 pins) PU = MDI, (transmit on RXP2 / RXM2 pins)
30	P1ANEN	lpu	1 = enable auto negotiation on port 1 0 = disable auto negotiation on port 1
31	P1SPD	lpd	1 = force port 1 to 100BT if P1ANEN = 0 0 = force port 1 to 10BT if P1ANEN = 0
32	P1DPX	lpd	1 = port 1 default to full duplex mode if P1ANEN = 1 and auto negotiation fails. Force port 1 in full-duplex mode if P1ANEN = 0. 0 = port 1 default to half duplex mode if P1ANEN = 1 and auto negotiation fails. Force port 1 in half duplex mode if P1ANEN = 0.
33	P1FFC	lpd	1 = always enable (force) port 1 flow control feature 0 = port 1 flow control feature enable is determined by auto negotiation result.
34	NC	lpd	No connect
35	NC	lpd	No connect
36	PWRDN	lpu	Chip power-down input (active low)
37	AGND	Gnd	Analog ground
38	VDDA	P	1.8V analog V _{DD}
39	AGND	Gnd	Analog ground
40	MUX1	I	Factory test pin - float for normal operation
41	MUX2	I	Factory test pin - float for normal operation
42	AGND	Gnd	Analog ground
43	VDDA	P	1.8V analog V _{DD}
44	FXSD1	I	Fiber signal detect/factory test pin

Note:

1. P = Power supply.

Gnd = Ground.

I = Input.

O = Output.

lpu = Input w/ internal pull-up.

lpd = Input w/ internal pull-down.

Pin Number	Pin Name	Type ⁽¹⁾	Description
45	RXP1	I/O	Physical receive or transmit signal (+ differential)
46	RXM1	I/O	Physical receive or transmit signal (– differential)
47	AGND	Gnd	Analog ground
48	TXP1	I/O	Physical transmit or receive signal (+ differential)
49	TXM1	I/O	Physical transmit or receive signal (– differential)
50	VDDATX	P	3.3V analog V _{DD}
51	VDDARX	P	3.3V analog V _{DD}
52	RXM2	I/O	Physical receive or transmit signal (– differential)
53	RXP2	I/O	Physical receive or transmit signal (+ differential)
54	AGND	Gnd	Analog ground.
55	TXM2	I/O	Physical transmit or receive signal (– differential)
56	TXP2	I/O	Physical transmit or receive signal (+ differential)
57	VDDA	P	1.8 analog V _{DD}
58	AGND	Gnd	Analog ground
59	TEST1	I	Factory test pin - float for normal operation
60	TEST2	Ipu	Factory test pin - float or pull-up for normal operation
61	ISET	O	Set physical transmit output current. Pull-down this pin with a 3.01K 1% resistor to ground.
62	AGND	Gnd	Analog ground
63	VDDAP	P	1.8V analog V _{DD} for PLL
64	AGND	Gnd	Analog ground.
65	X1	I	25MHz crystal/oscillator clock connections Pins (X1, X2) connect to a crystal. If an oscillator is used, X1 connects to a 3.3V tolerant oscillator and X2 is a no connect. Note: Clock is +/- 50ppm for both crystal and oscillator.
66	X2	O	
67	RST_N	Ipu	Hardware reset pin (active low)
68	BPEN	Ipd	Half-duplex backpressure 1 = enable 0 = disable
69	SMAC	Ipd	Special Mac-mode In this mode, the switch will do faster back-offs than normal. 1 = enable 0 = disable

Note:

1. P = Power supply.

Gnd = Ground.

I = Input.

O = Output.

Ipu = Input w/ internal pull-up.

Ipd = Input w/ internal pull-down.

Pin Number	Pin Name	Type ⁽¹⁾	Description
70	LEDSEL0	lpd	LED display mode select See description in pins 1 and 4.
71	SMTXEN	lpd	Switch MII transmit enable
72	SMTXD3	lpd	Switch MII transmit data bit 3
73	SMTXD2	lpd	Switch MII transmit data bit 2
74	SMTXD1	lpd	Switch MII transmit data bit 1
75	SMTXD0	lpd	Switch MII transmit data bit 0
76	SMTXER	lpd	Switch MII transmit error
77	SMTXC	lpd/O	Switch MII transmit clock Output in PHY MII mode Input in MAC MII mode
78	DGND	Gnd	Digital ground
79	VDDIO	P	3.3V digital V _{DD}
80	SMRXC	lpd/O	Switch MII receive clock. Output in PHY MII mode Input in MAC MII mode
81	SMRXDV	O	Switch MII receive data valid
82	SMRXD3	lpd/O	Switch MII receive data bit 3 Strap option: switch MII full-duplex flow control PD (default) = disable PU = enable
83	SMRXD2	lpd/O	Switch MII receive bit 2 Strap option: switch MII is in PD (default) = full-duplex mode PU = half-duplex mode
84	SMRXD1	lpd/O	Switch MII receive bit 1 Strap option: Switch MII is in PD (default) = 100Mbps mode PU = 10Mbps mode
85	SMRXD0	lpd/O	Switch MII receive bit 0 Strap option: switch will accept packet size up to PD (default) = 1536 bytes (inclusive) PU = 1522 bytes (tagged), 1518 bytes (untagged)
86	SCOL	lpd/O	Switch MII collision detect
87	SCRS	lpd/O	Switch MII carrier sense

Note:

1. P = Power supply.

Gnd = Ground.

O = Output.

lpd = Input w/ internal pull-down.

lpd/O = Input w/ internal pull-down during reset, output pin otherwise.

Pin Number	Pin Name	Type ⁽¹⁾	Description										
88	SCONF1	lpd	Switch MII interface configuration										
89	SCONF0	lpd	<table border="1"> <thead> <tr> <th>(SCONF1, SCONF0)</th> <th>Description</th> </tr> </thead> <tbody> <tr> <td>(0,0)</td> <td>disable, outputs tri-stated</td> </tr> <tr> <td>(0,1)</td> <td>PHY mode MII</td> </tr> <tr> <td>(1,0)</td> <td>MAC mode MII</td> </tr> <tr> <td>(1,1)</td> <td>PHY mode SNI</td> </tr> </tbody> </table>	(SCONF1, SCONF0)	Description	(0,0)	disable, outputs tri-stated	(0,1)	PHY mode MII	(1,0)	MAC mode MII	(1,1)	PHY mode SNI
(SCONF1, SCONF0)	Description												
(0,0)	disable, outputs tri-stated												
(0,1)	PHY mode MII												
(1,0)	MAC mode MII												
(1,1)	PHY mode SNI												
90	DGND	Gnd	Digital ground										
91	VDDC	P	1.8V digital VDD										
92	PRSEL1	lpd	Priority select. Select queue servicing if using split queues. Use the table below to select the desired servicing. Note that this selection effects all split transmit queue ports in the same way.										
93	PRSEL0	lpd		<table border="1"> <thead> <tr> <th>(PRSEL1, PRSEL0)</th> <th>Description</th> </tr> </thead> <tbody> <tr> <td>(0,0)</td> <td>Transmit all high priority before low priority</td> </tr> <tr> <td>(0,1)</td> <td>Transmit high priority and low priority at 10:1 ratio.</td> </tr> <tr> <td>(1,0)</td> <td>Transmit high priority and low priority at 5:1 ratio.</td> </tr> <tr> <td>(1,1)</td> <td>Transmit high priority and low priority at 2:1 ratio.</td> </tr> </tbody> </table>	(PRSEL1, PRSEL0)	Description	(0,0)	Transmit all high priority before low priority	(0,1)	Transmit high priority and low priority at 10:1 ratio.	(1,0)	Transmit high priority and low priority at 5:1 ratio.	(1,1)
(PRSEL1, PRSEL0)	Description												
(0,0)	Transmit all high priority before low priority												
(0,1)	Transmit high priority and low priority at 10:1 ratio.												
(1,0)	Transmit high priority and low priority at 5:1 ratio.												
(1,1)	Transmit high priority and low priority at 2:1 ratio.												
94	MDC	lpu	MII management interface: clock input										
95	MDIO	lpu/O	MII management interface: data input/output Note: an external 4.7K pull-up is needed on this pin when it is in use.										
96	SPIQ	Opu	SPI slave mode: serial data output See description in pins 100 and 101.										
97	SCL	lpu/O	SPI slave mode / I ² C slave mode: clock input I ² C master mode: clock output See description in pins 100 and 101.										
98	SDA	lpu/O	SPI slave mode: serial data input I ² C master/slave mode: serial data input/output See description in pins 100 and 101.										
99	SPIS_N	lpu	SPI slave mode: chip select (active low) When SPIS_N is high, the KS8993M is deselected and SPIQ is held in high impedance state. A high-to-low transition is used to initiate SPI data transfer. See description in pins 100 and 101.										

Note:

- 1. P = Power supply.
- Gnd = Ground.
- lpu = Input w/ internal pull-up.
- lpd = Input w/ internal pull-down.
- lpu/O = Input w/ internal pull-up during reset, output pin otherwise.
- Opu = Output w/ internal pull-up.

Pin Number	Pin Name	Type ⁽¹⁾	Description																																													
100	PS1	lpd	Serial bus configuration pins to select mode of access to KS8993M internal registers. [PS1, PS0] = [0, 0] — I²C master (EEPROM) mode (If EEPROM is not detected, the power-up default values of the KS8993M internal registers will be used.) <table border="1" style="width: 100%; border-collapse: collapse;"> <thead> <tr> <th>Interface Signals</th> <th>Type</th> <th>Description</th> </tr> </thead> <tbody> <tr> <td>SPIQ</td> <td>O</td> <td>Not used (tri-stated)</td> </tr> <tr> <td>SCL</td> <td>O</td> <td>I²C clock</td> </tr> <tr> <td>SDA</td> <td>I/O</td> <td>I²C data I/O</td> </tr> <tr> <td>SPIS_N</td> <td>lpu</td> <td>Not used</td> </tr> </tbody> </table> [PS1, PS0] = [0, 1] — I²C slave mode The external I ² C master will drive the SCL clock. The KS8993M device addresses are: 1011_1111 <read> 1011_1110 <write> <table border="1" style="width: 100%; border-collapse: collapse;"> <thead> <tr> <th>Interface Signals</th> <th>Type</th> <th>Description</th> </tr> </thead> <tbody> <tr> <td>SPIQ</td> <td>O</td> <td>Not used (tri-stated)</td> </tr> <tr> <td>SCL</td> <td>I</td> <td>I²C clock</td> </tr> <tr> <td>SDA</td> <td>I/O</td> <td>I²C data I/O</td> </tr> <tr> <td>SPIS_N</td> <td>lpu</td> <td>Not used</td> </tr> </tbody> </table> [PS1, PS0] = [1, 0] — SPI slave mode <table border="1" style="width: 100%; border-collapse: collapse;"> <thead> <tr> <th>Interface Signals</th> <th>Type</th> <th>Description</th> </tr> </thead> <tbody> <tr> <td>SPIQ</td> <td>O</td> <td>SPI data out</td> </tr> <tr> <td>SCL</td> <td>I</td> <td>SPI clock</td> </tr> <tr> <td>SDA</td> <td>I</td> <td>SPI data In</td> </tr> <tr> <td>SPIS_N</td> <td>lpu</td> <td>SPI chip select</td> </tr> </tbody> </table> [PS1, PS0] = [1, 1] – SMI-mode In this mode, the KS8993M provides access to all its internal 8 bit registers through its MDC and MDIO pins. Note: When (PS1, PS0) ≠ (1,1), the KS8993M provides access to its 16 bit MIIM registers through its MDC and MDIO pins.	Interface Signals	Type	Description	SPIQ	O	Not used (tri-stated)	SCL	O	I ² C clock	SDA	I/O	I ² C data I/O	SPIS_N	lpu	Not used	Interface Signals	Type	Description	SPIQ	O	Not used (tri-stated)	SCL	I	I ² C clock	SDA	I/O	I ² C data I/O	SPIS_N	lpu	Not used	Interface Signals	Type	Description	SPIQ	O	SPI data out	SCL	I	SPI clock	SDA	I	SPI data In	SPIS_N	lpu	SPI chip select
Interface Signals	Type	Description																																														
SPIQ	O	Not used (tri-stated)																																														
SCL	O	I ² C clock																																														
SDA	I/O	I ² C data I/O																																														
SPIS_N	lpu	Not used																																														
Interface Signals	Type	Description																																														
SPIQ	O	Not used (tri-stated)																																														
SCL	I	I ² C clock																																														
SDA	I/O	I ² C data I/O																																														
SPIS_N	lpu	Not used																																														
Interface Signals	Type	Description																																														
SPIQ	O	SPI data out																																														
SCL	I	SPI clock																																														
SDA	I	SPI data In																																														
SPIS_N	lpu	SPI chip select																																														
101	PS0	lpd																																														
102	PV31	lpu	Port 3 port-based VLAN mask bits – Use to select which ports may transmit packets received on port 3. PV31 = 1, port 1 may transmit packets received on port 3 PV31 = 0, port 1 will not transmit any packets received on port 3 PV32 = 1, port 2 may transmit packets received on port 3 PV32 = 0, port 2 will not transmit any packets received on port 3																																													
103	PV32	lpu																																														

Note:

- 1. I = Input. lpu = Input w/ internal pull-up. I/O = Bi-directional.
- O = Output. lpd = Input w/ internal pull-down.

Pin Number	Pin Name	Type ⁽¹⁾	Description
104	PV21	lpu	Port 2 port-based VLAN mask bits – Use to select which ports may transmit packets received on port 2. PV21 = 1, port 1 may transmit packets received on port 2 PV21 = 0, port 1 will not transmit any packets received on port 2 PV23 = 1, port 3 may transmit packets received on port 2 PV23 = 0, port 3 will not transmit any packets received on port 2
105	PV23	lpu	
106	DGND	Gnd	Digital ground
107	VDDIO	P	3.3V digital V _{DD}
108	PV12	lpu	Port 1 port-based VLAN mask bits – Use to select which ports may transmit packets received on port 1. PV12 = 1, port 2 may transmit packets received on port 1 PV12 = 0, port 2 will not transmit any packets received on port 1 PV13 = 1, port 3 may transmit packets received on port 1 PV13 = 0, port 3 will not transmit any packets received on port 1
109	PV13	lpu	
110	P3_1PEN	lpd	Enable 802.1p priority classification on port 3 ingress 1 = enable 0 = disable Enable is from the receive perspective. If 802.1p processing is disabled or there is no tag, priority is determined by the P3_PP pin.
111	P2_1PEN	lpd	Enable 802.1p priority classification on port 2 ingress 1 = enable 0 = disable Enable is from the receive perspective. If 802.1p processing is disabled or there is no tag, priority is determined by the P2_PP pin.
112	P1_1PEN	lpd	Enable 802.1p priority classification on port 1 ingress 1 = enable 0 = disable Enable is from the receive perspective. If 802.1p processing is disabled or there is no tag, priority is determined by the P1_PP pin.
113	P3_TXQ2	lpd	Select transmit queue split on port 3 1 = split 0 = no split The split sets up high and low priority queues. Packet priority classification is done on ingress ports, via port-based, 802.1p or TOS based scheme. The priority enabled queuing on port 3 is set by P3_TXQ2.

Note:

1. P = Power supply.

Gnd = Ground.

lpu = Input w/ internal pull-up.

lpd = Input w/ internal pull-down.

Pin Number	Pin Name	Type ⁽¹⁾	Description
114	P2_TXQ2	lpd	<p>Select transmit queue split on port 2</p> <p>1 = split 0 = no split</p> <p>The split sets up high and low priority queues. Packet priority classification is done on ingress ports, via port-based, 802.1p or TOS based scheme. The priority enabled queuing on port 2 is set by P2_TXQ2.</p>
115	P1_TXQ2	lpd	<p>Select transmit queue split on port 1</p> <p>1 = split 0 = no split</p> <p>The split sets up high and low priority queues. Packet priority classification is done on ingress ports, via port-based, 802.1p or TOS based scheme. The priority enabled queuing on port 1 is set by P1_TXQ2.</p>
116	P3_PP	lpd	<p>Select port-based priority on port 3 ingress</p> <p>1 = high 0 = low <default></p> <p>802.1p and DiffServ, if applicable, takes precedence.</p>
117	P2_PP	lpd	<p>Select port-based priority on port 2 ingress</p> <p>1 = high 0 = low <default></p> <p>802.1p and DiffServ, if applicable, takes precedence.</p>
118	P1_PP	lpd	<p>Select port-based priority on port 1 ingress</p> <p>1 = high 0 = low <default></p> <p>802.1p and DiffServ, if applicable, takes precedence.</p>
119	P3_TAGINS	lpd	<p>Enable tag insertion on port 3 egress</p> <p>1 = enable 0 = disable</p> <p>All packets transmitted from port 3 will have 802.1Q tag. Packets received with tag will be sent out intact. Packets received without tag will be tagged with ingress port's default tag.</p>
120	P2_TAGINS	lpd	<p>Enable tag insertion on port 2 egress</p> <p>1 = enable 0 = disable</p> <p>All packets transmitted from port 2 will have 802.1Q tag. Packets received with tag will be sent out intact. Packets received without tag will be tagged with ingress port's default tag.</p>

Note:

1. lpd = Input w/ internal pull-down.

Pin Number	Pin Name	Type ⁽¹⁾	Description
121	P1_TAGINS	lpd	<p>Enable tag insertion on port 1 egress</p> <p>1 = enable 0 = disable</p> <p>All packets transmitted from port 1 will have 802.1Q tag. Packets received with tag will be sent out intact. Packets received without tag will be tagged with ingress port's default tag.</p>
122	DGND	Gnd	Digital ground
123	VDDC	P	1.8V digital V _{DD}
124	P3_TAGRM	lpd	<p>Enable tag removal on port 3 egress</p> <p>1 = enable 0 = disable</p> <p>All packets transmitted from port 3 will not have 802.1Q tag. Packets received with tag will be modified by removing 802.1Q tag. Packets received without tag will be sent out intact.</p>
125	P2_TAGRM	lpd	<p>Enable tag removal on port 2 egress</p> <p>1 = enable 0 = disable</p> <p>All packets transmitted from port 2 will not have 802.1Q tag. Packets received with tag will be modified by removing 802.1Q tag. Packets received without tag will be sent out intact.</p>
126	P1_TAGRM	lpd	<p>Enable tag removal on port 1 egress</p> <p>1 = enable 0 = disable</p> <p>All packets transmitted from port 1 will not have 802.1Q tag. Packets received with tag will be modified by removing 802.1Q tag. Packets received without tag will be sent out intact.</p>
127	TESTEN	lpd	<p>Scan Test Enable</p> <p>For normal operation, pull-down this pin to ground.</p>
128	SCANEN	lpd	<p>Scan Test Scan Mux Enable</p> <p>For normal operation, pull-down this pin to ground.</p>

Note:

1. P = Power supply.

Gnd = Ground.

lpd = Input w/ internal pull-down.

Pin Configuration

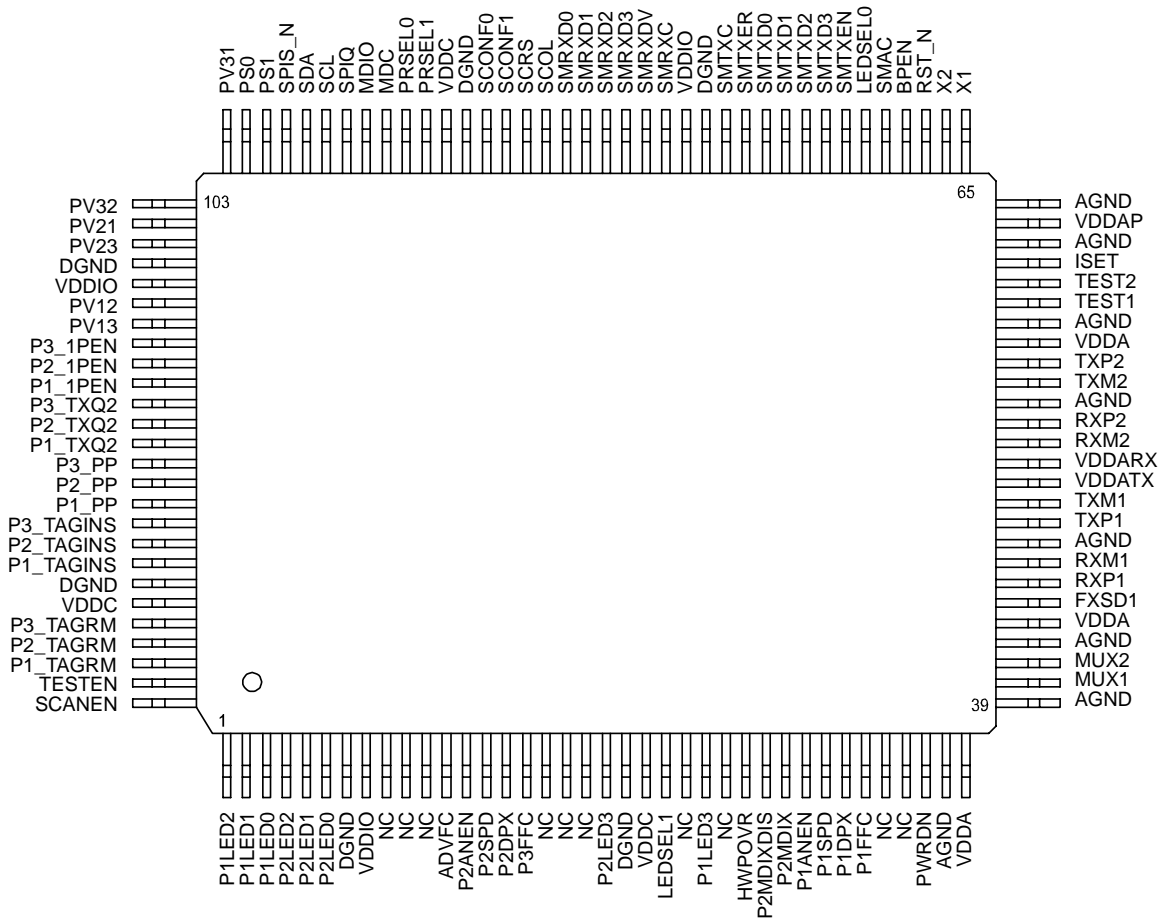

128-Pin PQFP (Top View)

Functional Description

The KS8993M contains two 10/100 physical layer transceivers and three MAC units with an integrated Layer 2 managed switch.

The KS8993M has the flexibility to reside in either a managed or unmanaged design. In a managed design, the host processor has complete control of the KS8993M via the SMI interface, MIIM interface, SPI bus, or I²C bus. An unmanaged design is achieved through I/O strapping and/or EEPROM programming at system reset time.

On the media side, the KS8993M supports IEEE 802.3 10BASE-T and 100BASE-TX on both PHY ports, and 100BASE-FX on PHY port 1. The KS8993M can be used as a media converter.

The KS8993ML is the single supply version with all the identical rich features of the KS8993M. In the KS8993ML version, pin number 22 provides 1.8V output power to the KS8993ML's V_{DDC}, V_{DDA}, and V_{DDAP} power pins. Refer to the Pin Description table for information about pin 22 (Pin Description and I/O Assignment).

Physical signal transmission and reception are enhanced through the use of patented analog circuitries that make the design more efficient and allow for lower power consumption and smaller chip die size.

Functional Overview: Physical Layer Transceiver

100BASE-TX Transmit

The 100BASE-TX transmit function performs parallel to serial conversion, 4B/5B coding, scrambling, NRZ to NRZI conversion, MLT3 encoding and transmission. The circuit starts with a parallel-to-serial conversion, which converts the MII data from the MAC into a 125MHz serial bit stream. The data and control stream is then converted into 4B/5B coding and followed by a scrambler. The serialized data is further converted from NRZ to NRZI format, and then transmitted in MLT3 current output. The output current is set by an external 1% 3.01 K Ω resistor for the 1:1 transformer ratio. It has a typical rise/fall time of 4ns and complies with the ANSI TP-PMD standard regarding amplitude balance, overshoot, and timing jitter. The wave-shaped 10BASE-T output is also incorporated into the 100BASE-TX transmitter.

100BASE-TX Receive

The 100BASE-TX receiver function performs adaptive equalization, DC restoration, MLT3 to NRZI conversion, data and clock recovery, NRZI to NRZ conversion, de-scrambling, 4B/5B decoding and serial-to-parallel conversion. The receiving side starts with the equalization filter to compensate for inter-symbol interference (ISI) over the twisted pair cable. Since the amplitude loss and phase distortion is a function of the length of the cable, the equalizer has to adjust its characteristics to optimize the performance. In this design, the variable equalizer will make an initial estimation based on comparisons of incoming signal strength against some known cable characteristics, then it tunes itself for optimization. This is an ongoing process and can self adjust against environmental changes such as temperature variations.

The equalized signal then goes through a DC restoration and data conversion block. The DC restoration circuit is used to compensate for the effect of base line wander and improve the dynamic range. The differential data conversion circuit converts the MLT3 format back to NRZI. The slicing threshold is also adaptive.

The clock recovery circuit extracts the 125MHz clock from the edges of the NRZI signal. This recovered clock is then used to convert the NRZI signal into the NRZ format. The signal is then sent through the de-scrambler followed by the 4B/5B decoder. Finally, the NRZ serial data is converted to the MII format and provided as the input data to the MAC.

PLL Clock Synthesizer

The KS8993M generates 125MHz, 31.25MHz, 25MHz, and 10MHz clocks for system timing. Internal clocks are generated from an external 25MHz crystal or oscillator.

Scrambler/De-scrambler (100BASE-TX Only)

The purpose of the scrambler is to spread the power spectrum of the signal in order to reduce EMI and baseline wander. Transmitted data is scrambled through the use of an 11-bit wide linear feedback shift register (LFSR). The scrambler can generate a 2047-bit non-repetitive sequence. The receiver will then de-scramble the incoming data stream with the same sequence at the transmitter.

100BASE-FX Operation

100BASE-FX operation is very similar to 100BASE-TX operation with the differences being that the scrambler / de-scrambler and MLT3 encoder / decoder are bypassed on transmission and reception. In 100BASE-FX mode, the auto negotiation feature is bypassed since there is no standard that supports fiber auto negotiation. The auto-MDI/MDI-X feature is also disabled.

100BASE-FX Signal Detection

In fiber operation, the KS8993M's FXSD1 (fiber signal detect) input pin is usually connected to the fiber transceiver's SD (signal detect) output pin. 100BASE-FX mode is activated when the FXSD1 input pin is greater than 1V. When FXSD1 is between 1V and 1.8V, no fiber signal is detected and a far end fault (FEF) is generated. When FXSD1 is over 2.2V, the fiber signal is detected.

Alternatively, the designer may choose not to implement the FEF feature. In this case, the FXSD1 input pin is tied high to force 100BASE-FX mode.

100BASE-FX signal detection is summarized in the following table:

Part Number	Mode
Less than 0.2V	TX mode
Greater than 1V, but less than 1.8V	FX mode No signal detected. Far-end fault generated
Greater than 2.2V	FX mode Signal detected

Table 1. FX and TX Mode Selection

To ensure proper operation, a resistive voltage divider is recommended to adjust the fiber transceiver's SD output voltage swing to match the KS8993M's FXSD1 input voltage threshold.

100BASE-FX Far End Fault

An FEF occurs when the signal detection is logically false on the receive side of the fiber transceiver. The KS8993M detects a FEF when its FXSD1 input is between 1.0V and 1.8V. When an FEF occurs, the transmission side signals the other end of the link by sending 84 1's followed by a zero in the idle period between frames.

Upon receiving an FEF, the LINK will go down (even when a fiber signal is detected) to indicate a fault condition. The transmitting side is not affected when an FEF is received, and will continue to send out its normal transmit pattern from the MAC. By default, FEF is enabled. The FEF feature can be disabled through register setting.

10BASE-T Transmit

The output 10BASE-T driver is incorporated into the 100BASE-T driver to allow transmission with the same

magnetic. They are internally wave-shaped and pre-emphasized into outputs with a typical 2.3V amplitude. The harmonic contents are at least 27dB below the fundamental when driven by an all-ones Manchester-encoded signal.

10BASE-T Receive

On the receive side, input buffers and level detecting squelch circuits are employed. A differential input receiver circuit and a PLL perform the decoding function. The Manchester-encoded data stream is separated into clock signal and NRZ data. A squelch circuit rejects signals with levels less than 400 mV or with short pulse widths in order to prevent noises at the RXP or RXM input from falsely triggering the decoder. When the input exceeds the squelch limit, the PLL locks onto the incoming signal and the KS8993M decodes a data frame. The receiver clock is maintained active during idle periods in between data reception.

Power Management

The KS8993M features a per-port power down mode. To save power, the user can power down ports that are not in use by setting the port control registers, or MII control registers. In addition, there is a full chip power down mode. When activated, the entire chip will be shut down.

MDI /MDI-X Auto Crossover

The KS8993M supports MDI/ DI-X auto crossover. This facilitates the use of either a straight connection CAT-5 cable or a crossover CAT-5 cable. The auto-sense function will detect remote transmit and receive pairs, and correctly assign the transmit and receive pairs from the KS8993M device. This feature can be extremely useful when end users are unaware of cable types and can also save on an additional uplink configuration connection. The auto-crossover feature can be disabled through the port control registers.

Based on the IEEE 802.3 standard, the MDI and MDI-X definitions are as follows:

MDI		MDI-X	
RJ45 Pins	Signals	RJ-45 Pins	Signals
1	TD+	1	RD+
2	TD-	2	RD-
3	RD+	3	TD+
6	RD-	6	TD-

Table 2. MDI/MDI-X Pin Definitions

Straight Cable

A straight cable connects an MDI device to an MDI-X device, or an MDI-X device to an MDI device. The following diagram depicts a typical straight cable connection between a NIC card (MDI) and a switch, or hub (MDI-X).

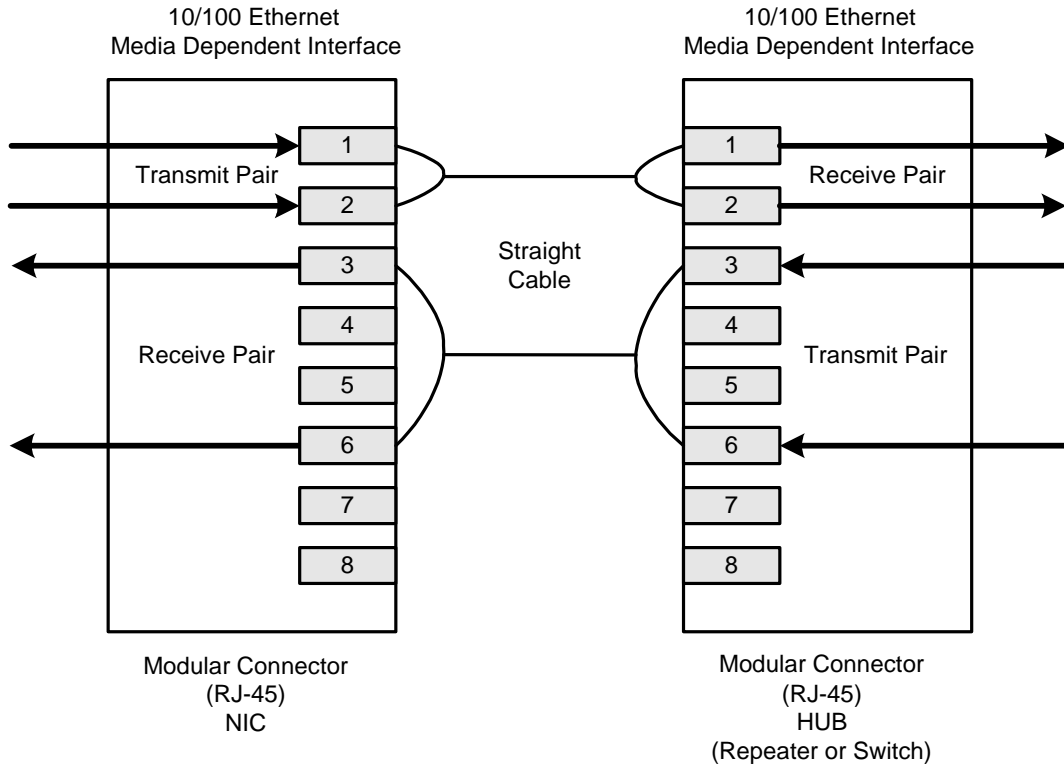

Figure 1. Typical Straight Cable Connection

Crossover Cable

A crossover cable connects an MDI device to another MDI device, or an MDI-X device to another MDI-X device. The following diagram shows a typical crossover cable connection between two switches or hubs (two MDI-X devices).

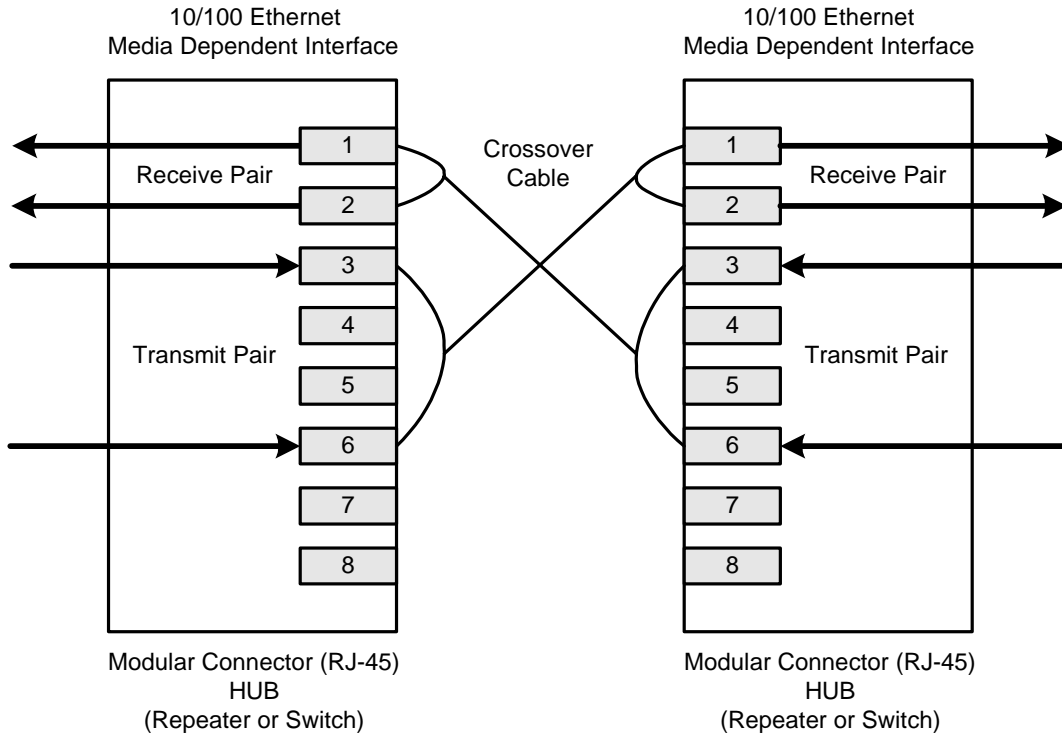

Figure 2. Typical Crossover Cable Connection

Auto Negotiation

The KS8993M conforms to the auto negotiation protocol as described by the 802.3 committee. Auto negotiation allows unshielded twisted pair (UTP) link partners to select the best common mode of operation. In auto negotiation, the link partners advertise capabilities across the link to each other. If auto negotiation is not supported or the link partner to the KS8993M is forced to bypass auto negotiation, then the mode is set by observing the signal at the receiver. This is known as parallel mode because while the transmitter is sending auto negotiation advertisements, the receiver is listening for advertisements or a fixed signal protocol.

The link setup is shown in the following flow diagram.

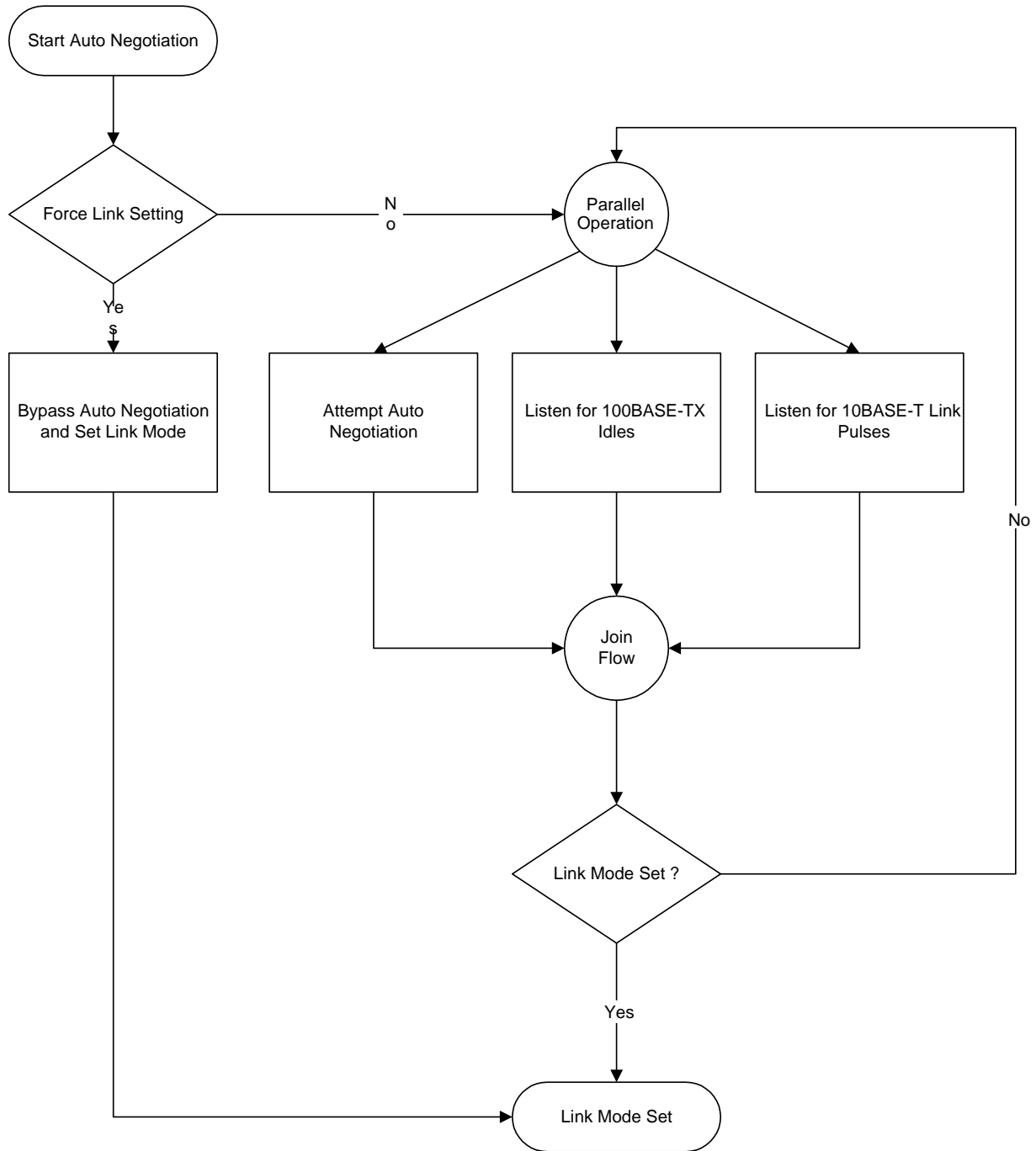

Figure 3. Auto Negotiation and Parallel Operation

Functional Overview: MAC and Switch

Address Lookup

The internal lookup table stores MAC addresses and their associated information. It contains a 1K uni-cast address table plus switching information. The KS8993M is guaranteed to learn 1K addresses and distinguishes itself from hash-based lookup tables, which depending on the operating environment and probabilities, may not guarantee the absolute number of addresses that can be learned.

Learning

The internal lookup engine will update its table with a new entry if the following conditions are met:

1. The received packet's SA does not exist in the lookup table.
 2. The received packet is good; the packet has no receiving errors, and is of legal length.
- The lookup engine will insert the qualified SA into the table, along with the port number and time stamp. If the table is full, the last entry of the table will be deleted to make room for the new entry.

Migration

The internal lookup engine also monitors whether a station has moved. If so, it will update the table accordingly. Migration happens when the following conditions are met:

1. The received packet's SA is in the table but the associated source port information is different.
2. The received packet is good; the packet has no receiving errors, and is of legal length.

The lookup engine will update the existing record in the table with the new source port information.

Aging

The lookup engine will update the time stamp information of a record whenever the corresponding SA appears. The time stamp is used in the aging process. If a record is not updated for a period of time, the lookup engine will remove the record from the table. The lookup engine constantly performs the aging process and will continuously remove aging records. The aging period is about 200 seconds. This feature can be enabled or disabled through Global Register 3 (0x03).

Forwarding

The KS8993M will forward packets using the algorithm that is depicted in the following flowcharts. Figure 4 shows stage one of the forwarding algorithm where the search engine looks up the VLAN ID, static table, and dynamic table for the destination address, and comes up with "port to forward 1" (PTF1). PTF1 is then further modified by spanning tree, IGMP snooping, port mirroring, and port VLA processes to come up with "port to forward 2" (PTF2), as shown in Figure 5. The packet is sent to PTF2.

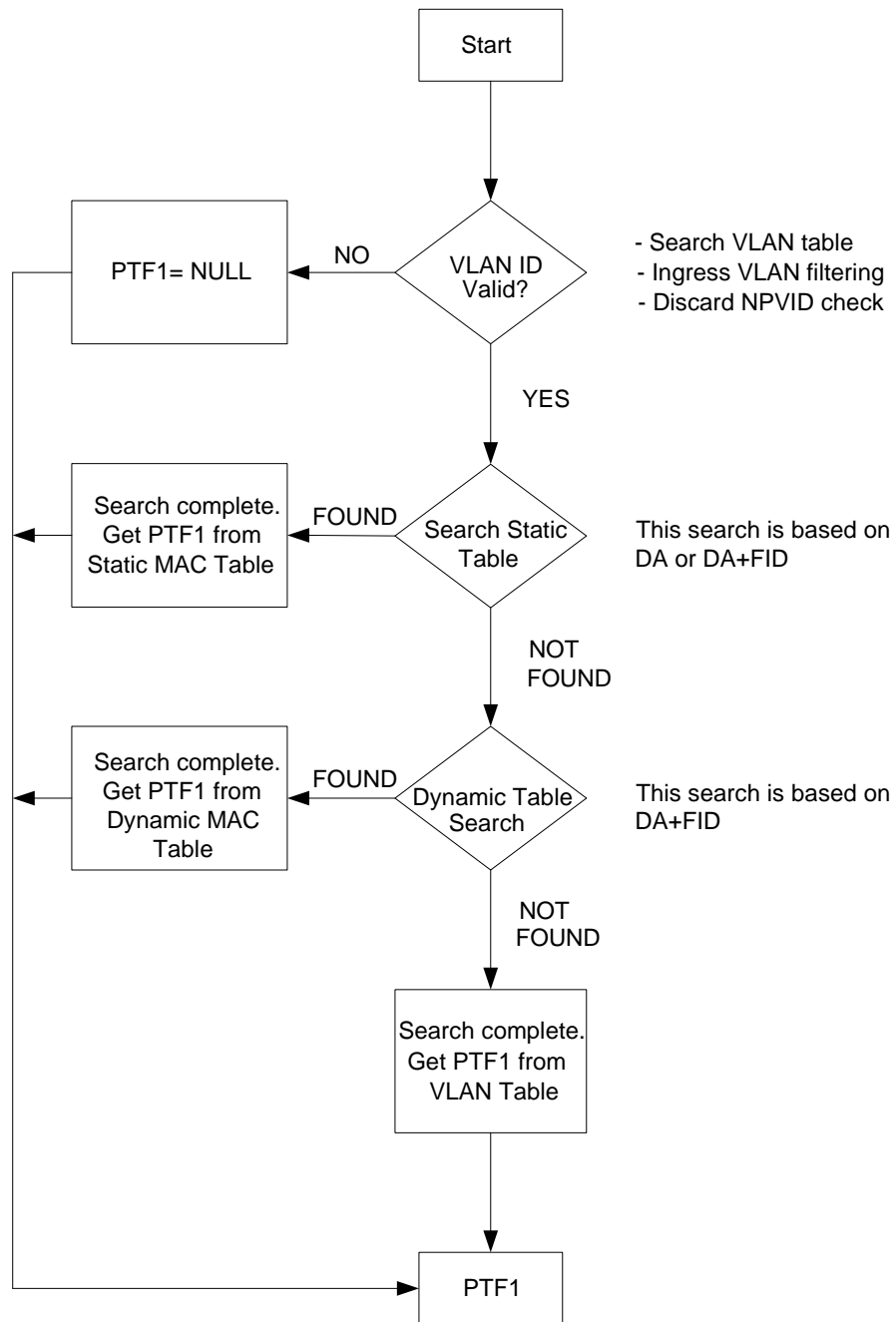

Figure 4. Destination Address Lookup Flow Chart, Stage 1

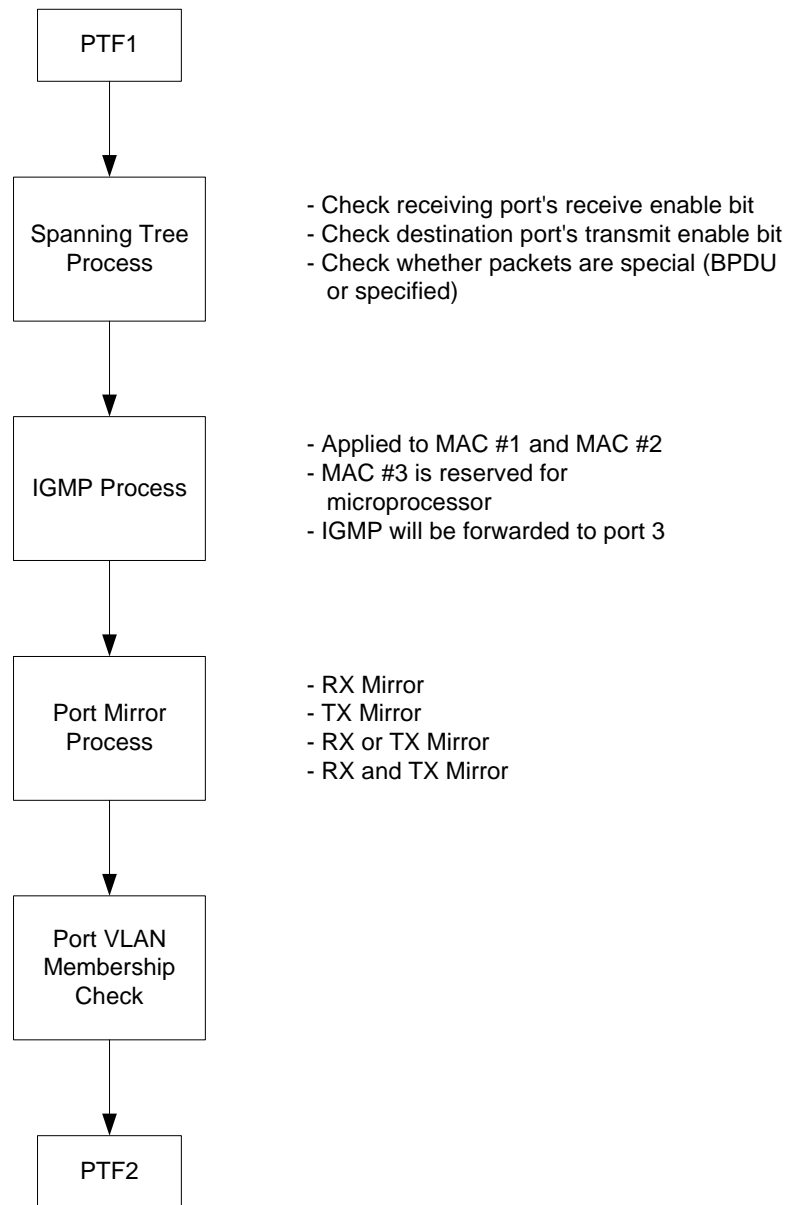

Figure 5. Destination Address Resolution Flow Chart, Stage 2

The KS8993M will not forward the following packets:

1. Error packets. These include framing errors, FCS errors, alignment errors, and illegal size packet errors.
2. 802.3x pause frames. The KS8993M will intercept these packets and perform the appropriate actions.
3. "Local" packets. Based on destination address (DA) lookup. If the destination port from the lookup table matches the port where the packet was from, the packet is defined as "local."

Switching Engine

The KS8993M features a high-performance switching engine to move data to and from the MACs' packet buffers. It operates in store and forward mode, while the efficient switching mechanism reduces overall latency.

The KS8993M has a 32kB internal frame buffer. This resource is shared between all three ports. The buffer-sharing mode can be programmed through Global Register 2 (0x02). In one mode, ports are allowed to use any free buffers in the buffer pool. In the second mode, each port is only allowed to use one third of the total buffer pool. There are a total of 250 buffers available. Each buffer is sized at 128B.

MAC Operation

The KS8993M strictly abides by IEEE 802.3 standards to maximize compatibility.

Inter Packet Gap (IPG)

If a frame is successfully transmitted, the 96 bits time IPG is measured between the two consecutive MTXEN. If the current packet is experiencing collision, the 96 bits time IPG is measured from MCRS and the next MTXEN.

Back-Off Algorithm

The KS8993M implements the IEEE standard 802.3 binary exponential back-off algorithm, and optional "aggressive mode" back-off. After 16 collisions, the packet will be optionally dropped depending on the chip configuration in Global Register 3 (0x03)

Late Collision

If a transmit packet experiences collisions after 512 bit times of the transmission, the packet will be dropped.

Illegal Frames

The KS8993M discards frames less than 64 bytes and can be programmed to accept frames up to 1536 bytes in Global Register 4 (0x04). For special applications, the KS8993M can also be programmed to accept frames up to 1916 bytes in the same global register. Since the KS8993M supports VLAN tags, the maximum sizing is adjusted when these tags are present. See the EEPROM section for programming options.

Flow Control

The KS8993M supports standard 802.3x flow control frames on both transmit and receive sides.

On the receive side, if the KS8993M receives a pause control frame, the KS8993M will not transmit the next normal frame until the timer, specified in the pause control frame, expires. If another pause frame is received before the current timer expires, the timer will be updated with the new value in the second pause frame. During this period (being flow controlled), only flow control packets from the KS8993M will be transmitted.

On the transmit side, the KS8993M has intelligent and efficient ways to determine when to invoke flow control. The flow control is based on availability of the system resources, including available buffers, available transmit queues and available receive queues.

The KS8993M will flow control a port, which just received a packet, if the destination port resource is being used up. The KS8993M will issue a flow control frame (XOFF), containing the maximum pause time defined in IEEE standard 802.3x. Once the resource is freed up, the KS8993M will send out the other flow control frame (XON) with zero pause time to turn off the flow control (turn on transmission to the port). A hysteresis feature is provided to prevent the flow control mechanism from being activated and deactivated too many times.

The KS8993M will flow control all ports if the receive queue becomes full.

Half-Duplex Backpressure

A half-duplex backpressure option (Note: not in IEEE 802.3 standards) is also provided. The activation and deactivation conditions are the same as the above in full duplex mode. If backpressure is required, the KS8993M will send preambles to defer the other stations' transmission (carrier sense deference). To avoid jabber and excessive deference defined in 802.3 standard, after a certain time it will discontinue the carrier sense but it will raise the carrier sense quickly. This short silent time (no carrier sense) is to prevent other stations from sending

out packets and keeps other stations in carrier sense deferred state. If the port has packets to send during a backpressure situation, the carrier sense type back pressure will be interrupted and those packets will be transmitted instead. If there are no more packets to send, carrier sense type backpressure will be active again until switch resources free up. If a collision occurs, the binary exponential back-off algorithm is skipped and carrier sense is generated immediately, reducing the chance of further colliding and maintaining carrier sense to prevent reception of packets.

To ensure no packet loss in 10 BASE-T or 100 BASE-TX half duplex modes, the user must enable the following:

1. Aggressive back off (Global Register 3 (0x03), bit 0 or external strap-in pin SMAC = high)
2. No excessive collision drop (Global Register 4 (0x04), bit 3 or external strap-in pin SMAC = high)

These bits are not set as defaults because this is not the IEEE standard.

Broadcast Storm Protection

The KS8993M has an intelligent option to protect the switch system from receiving too many broadcast packets. Broadcast packets will be forwarded to all ports except the source port, and thus use too many switch resources (bandwidth and available space in transmit queues). The KS8993M has the option to include "multicast packets" for storm control. The broadcast storm rate parameters are programmed globally, and can be enabled or disabled on a per port basis. The rate is based on a 67ms interval for 100BT and a 500ms interval for 10BT. At the beginning of each interval, the counter is cleared to zero, and the rate limit mechanism starts to count the number of bytes during the interval. The rate definition is described in Global Register 6 (0x06) and 7 (0x07). The default setting for registers 6 and 7 is 0x63, which is 99 decimal. This is equal to a rate of 1%, calculated as follows:

$$148,800 \text{ frames/sec} * 67\text{ms/interval} * 1\% = 99 \text{ frames/interval (approx.)} = 0x63$$

MII Interface Operation

The MII is specified by the IEEE 802.3 standards committee and provides a common interface between physical layer and MAC layer devices. The MII Interface provided by the KS8993M is connected to the device's third MAC. The interface contains two distinct groups of signals: one for transmission and the other for reception. The following table describes the signals used in the MII interface.

KS8993M PHY-Mode Connections		Pin Descriptions	KS8993M MAC-Mode Connections	
External MAC Controller Signals	KS8993M PHY Signals		External PHY Signals	KS8993M MAC Signals
MTXEN	SMTXEN	Transmit enable	MTXEN	SMRXDV
MTXER	SMTXER	Transmit error	MTXER	(not used)
MTXD3	SMTXD[3]	Transmit data bit 3	MTXD3	SMRXD[3]
MTXD2	SMTXD[2]	Transmit data bit 2	MTXD2	SMRXD[2]
MTXD1	SMTXD[1]	Transmit data bit 1	MTXD1	SMRXD[1]
MTXD0	SMTXD[0]	Transmit data bit 0	MTXD0	SMRXD[0]
MTXC	SMTXC	Transmit clock	MTXC	SMRXC
MCOL	SCOL	Collision detection	MCOL	SCOL
MCRS	SCRS	Carrier sense	MCRS	SCRS
MRXDV	SMRXDV	Receive data valid	MRXDV	SMTXEN
MRXER	(not used)	Receive error	MRXER	SMTXER
MRXD3	SMRXD[3]	Receive data bit 3	MRXD3	SMTXD[3]
MRXD2	SMRXD[2]	Receive data bit 2	MRXD2	SMTXD[2]
MRXD1	SMRXD[1]	Receive data bit 1	MRXD1	SMTXD[1]
MRXD0	SMRXD[0]	Receive data bit 0	MRXD0	SMTXD[0]
MRXC	SMRXC	Receive clock	MRXC	SMTXC

Table 3. MII Signals

The MII interface operates in either PHY mode or MAC mode. The interface is a nibble wide data interfaces and therefore run at ¼ the network bit rate (not encoded). Additional signals on the transmit side indicate when data is valid or when an error occurs during transmission. Likewise, the receive side has indicators that convey when the data is valid and without physical layer errors. For half duplex operation there is a signal that indicates a collision has occurred during transmission.

Note that the signal MRXER is not provided on the interface for PHY mode operation and the signal MTXER is not provided on the interface for MAC mode operation. Normally MRXER would indicate a receive error coming from the physical layer device. MTXER would indicate a transmit error from the MAC device. These signals are not appropriate for this configuration. For PHY mode operation, if the device interfacing with the KS8993M has an MRXER pin, it should be tied low. For MAC mode operation, if the device interfacing with the KS8993M has an MTXER pin, it should be tied low.

SNI (7-Wire) Operation

The serial network interface (SNI) or 7-wire is compatible with some controllers used for network layer protocol processing. In SNI mode, the KS8993M acts like a PHY and the external controller functions as the MAC. The KS8993M can interface directly with external controllers using the 7-wire interface. These signals are divided into two groups, one for transmission and the other for reception. The signals involved are described in the following table.

Pin Descriptions	External MAC Controller Signals	KS8993M PHY Signals
Transmit enable	TXEN	SMTXEN
Serial transmit data	TXD	SMTXD[0]
Transmit clock	TXC	SMTXC
Collision detection	COL	SCOL
Carrier sense	CRS	SMRXDV
Serial receive data	RXD	SMRXD[0]
Receive clock	RXC	SMRXC

Table 4. SNI Signals

The SNI interface is a bit wide data interface and therefore runs at the network bit rate (not encoded). An additional signal on the transmit side indicates when data is valid. Similarly, the receive side has an indicator that conveys when the data is valid.

For half duplex operation, the KS8993M's SCOL signal is used to indicate that a collision has occurred during transmission.

MII Management Interface (MIIM)

The KS8993M supports the IEEE 802.3 MII Management Interface, also known as the Management Data Input/Output (MDIO) Interface. This interface allows upper-layer devices to monitor and control the states of the KS8993M. An external device with MDC/MDIO capability can be used to read the PHY status or configure the PHY settings. Further details on the MIIM interface can be found in section 22.2.4.5 of the IEEE 802.3 specification.

The MIIM interface consists of the following:

- A physical connection that incorporates the data line (MDIO) and the clock line (MDC).
- A specific protocol that operates across the aforementioned physical connection that allows an external controller to communicate with the KS8993M device.
- Access to a set of six 16-bits registers, consisting of standard MIIM registers [0:5].

The following table depicts the MII Management Interface frame format.

	Preamble	Start of Frame	Read/Write OP Code	PHY Address Bits [4:0]	REG Address Bits [4:0]	TA	Data Bits [15:0]	Idle
Read	32 1's	01	10	xx0AA	RRRRR	Z0	DDDDDDDD_DDDDDDDD	Z
Write	32 1's	01	01	xx0AA	RRRRR	10	DDDDDDDD_DDDDDDDD	Z

Table 5. MII Management Interface Frame Format

For the KS8993M, MIIM register access is selected when bit 2 of the PHY address is set to '0'. PHY address bits [4:3] are not defined for MIIM register access, and hence can be set to either 0's or 1's in read/write operation.

Serial Management Interface (SMI)

The SMI is the KS8993M non-standard MIIM interface that provides access to all KS8993M configuration registers. This interface allows an external device to completely monitor and control the states of the KS8993M.

The SMI interface consists of the following:

- A physical connection that incorporates the data line (MDIO) and the clock line (MDC).
- A specific protocol that operates across the aforementioned physical connection that allows an external controller to communicate with the KS8993M device.
- Access to all KS8993M configuration registers. Registers access includes the Global, Port and Advanced Control Registers 0-127 (0x00 – 0x7F), and indirect access to the standard MIIM registers [0:5].

The following table depicts the SMI frame format.

	Preamble	Start of Frame	Read/Write OP Code	PHY Address Bits [4:0]	REG Address Bits [4:0]	TA	Data Bits [15:0]	Idle
Read	32 1's	01	10	RR1xx	RRRRR	Z0	0000_0000_DDDD_DDDD	Z
Write	32 1's	01	01	RR1xx	RRRRR	10	xxxx_xxxx_DDDD_DDDD	Z

Table 6. Serial Management Interface (SMI) Frame Format

For the KS8993M, SMI register access is selected when bit 2 of the PHY address is set to '1'. PHY address bits [1:0] are not defined for SMI register access, and hence can be set to either 0's or 1's in read/write operation.

To access the KS8993M registers 0-127 (0x00 – 0x7F), the following applies:

- PHYAD[4:3] and REGAD[4:0] are concatenated to form the 7-bits address; that is, {PHYAD[4:3], REGAD[4:0]} = bits [6:0] of the 7-bits address.

- Registers are 8 data bits wide. For read operation, data bits [15:8] are read back as 0's. For write operation, data bits [15:8] are not defined, and hence can be set to either 0's or 1's.

SMI register access is the same as the MIIM register access, except for the register access requirements presented in this section.

Advanced Switch Functions

Spanning Tree Support

To support spanning tree, port 3 is the designated port for the processor.

The other ports (port 1 and port 2) can be configured in one of the five spanning tree states via “transmit enable”, “receive enable” and “learning disable” register settings in registers 18 and 34 for ports 1 and 2, respectively. The following description shows the port setting and software actions taken for each of the five spanning tree states.

Disable state: The port should not forward or receive any packets.
Learning is disabled.

Port setting:

“transmit enable = 0, receive enable = 0, learning disable =1”

Software action:

The processor should not send any packets to the port. The switch may still send specific packets to the processor (packets that match some entries in the “static MAC table” with “overriding bit” set) and the processor should discard those packets. Note: processor is connected to port 3 via MII interface. Address learning is disabled on the port in this state.

Blocking state: Only packets to the processor are forwarded.
Learning is disabled.

Port setting:

“transmit enable = 0, receive enable = 0, learning disable =1”

Software action:

The processor should not send any packets to the port(s) in this state. The processor should program the “Static MAC table” with the entries that it needs to receive (e.g. BPDU packets). The “overriding” bit should also be set so that the switch will forward those specific packets to the processor. Address learning is disabled on the port in this state.

Listening state: Only packets to and from the processor are forwarded.
Learning is disabled.

Port setting:

“transmit enable = 0, receive enable = 0, learning disable =1”

Software action:

The processor should program the “Static MAC table” with the entries that it needs to receive (e.g., BPDU packets). The “overriding” bit should be set so that the switch will forward those specific packets to the processor. The processor may send packets to the port(s) in this state, see “Special Tagging Mode” for details. Address learning is disabled on the port in this state.

Learning state: Only packets to and from the processor are forwarded.
Learning is enabled.

Port setting:

“transmit enable = 0, receive enable = 0, learning disable = 0”

Software action:

The processor should program the “Static MAC table” with the entries that it needs to receive (e.g., BPDU packets). The “overriding” bit should be set so that the switch will forward those specific packets to the processor. The processor may send packets to the port(s) in this state, see “Special Tagging Mode” for details. Address learning is enabled on the port in this state.

Forwarding state:

Packets are forwarded and received normally.
Learning is enabled.

Port setting:

“transmit enable = 1, receive enable = 1, learning disable = 0”

Software action:

The processor should program the “Static MAC table” with the entries that it needs to receive (e.g., BPDU packets). The “overriding” bit should be set so that the switch will forward those specific packets to the processor. The processor may send packets to the port(s) in this state, see “Special Tagging Mode” for details. Address learning is enabled on the port in this state.

Upstream Special Tagging Mode

Upstream Special Tagging Mode is designed for spanning tree protocol IGMP snooping and is flexible for use in other applications. The Upstream Special Tagging Mode, similar to 802.1Q, requires software to change network drivers to modify/strip/interpret the special tag. This mode is enabled by setting both register 11 bit 0 and register 48 bit 2 to “1”.

802.1Q Tag Format	Special Tag Format
TPID (tag protocol identifier, 0x8100) + TCI.	STPID (special tag identifier, 0x810 + 4 bit for “port mask”) + TCI

Table 7. Upstream Special Tagging Mode Format

The STPID is only seen and used by the port 3 interface, which should be connected to a processor.

The KS8993M uses a non-zero “port mask” to bypass the lookup result and override any port setting, regardless of port states (disable, blocking, listening, learning).

For packets from regular ports (port 1 & port 2) to port 3, the port mask is used to tell the processor which port the packets were received on, defined as follows:

- “0001” from port 1
- “0010” from port 2

No port mask values, other than the previous two defined ones, should be received in Upstream Special Tagging Mode. The egress rules are defined as follows:

Ingress Packets	Egress Action to Tag Field
Tagged with 0x8100 + TCI	<ul style="list-style-type: none"> - Modify TPID to 0x810 + “port mask”, which indicates source port. - No change to TCI if VID is not null - Replace null VID with ingress port VID - Recalculate CRC
Not tagged.	<ul style="list-style-type: none"> - Insert TPID to 0x810 + “port mask”, which indicates source port - Insert TCI with ingress port VID - Recalculate CRC

Table 8. STPID Egress Rules (Switch Port 3 to Processor)

IGMP Support

For IGMP support in layer 2, the KS8993M provides two components:

“IGMP” Snooping

The KS8993M will trap IGMP packets and forward them only to the processor (port 3). The IGMP packets are identified as IP packets (either Ethernet IP packets, or IEEE 802.3 SNAP IP packets) with IP version = 0x4 and protocol version number = 0x2.

“Multicast Address Insertion” in the Static MAC Table

Once the multicast address is programmed in the Static MAC Table, the multicast session will be trimmed to the subscribed ports, instead of broadcasting to all ports.

To enable IGMP support, set register 5 bit 6 to “1”. Also, “Special Tagging Mode” needs to be enabled, so that the processor knows which port the IGMP packet was received on. This is achieved by setting both register 11 bit 0 and register 48 bit 2 to “1.”

Port Mirroring Support

KS8993M supports “Port Mirroring” comprehensively as:

1. “receive only” mirror on a port All the packets received on the port will be mirrored on the sniffer port. For example, port 1 is programmed to be “receive sniff” and port 3 is programmed to be the “sniffer port”. A packet received on port 1 is destined to port 2 after the internal lookup. The KS8993M will forward the packet to both port 2 and port 3. The KS8993M can optionally forward even “bad” received packets to the “sniffer port”.

2. “transmit only” mirror on a port All the packets transmitted on the port will be mirrored on the sniffer port. For example, port 1 is programmed to be “transmit sniff” and port 3 is programmed to be the “sniffer port”. A packet received on port 2 is destined to port 1 after the internal lookup. The KS8993M will forward the packet to both port 1 and port 3.

3. “receive and transmit” mirror on two ports All the packets received on port A and transmitted on port B will be mirrored on the sniffer port. To turn on the “AND” feature, set register 5 bit 0 to “1”. For example, port 1 is programmed to be “receive sniff”, port 2 is programmed to be “transmit sniff” and port 3 is programmed to be the “sniffer port”. A packet received on port 1 is destined to port 2 after the internal lookup. The KS8993M will forward the packet to both port 2 and port 3.

Multiple ports can be selected to be “receive sniff” or “transmit sniff”. And any port can be selected to be the “sniffer port”. All these per port features can be selected through registers 17, 33 and 49 for ports 1, 2 and 3, respectively.

IEEE 802.1Q VLAN Support

The KS8993M supports 16 active VLANs out of the 4096 possible VLANs specified in the IEEE 802.1Q specification. KS8993M provides a 16-entries VLAN Table, which converts the 12-bits VLAN ID (VID) to the 4-bits Filter ID (FID) for address lookup. If a non-tagged or null-VID-tagged packet is received, the ingress port default VID is used for lookup. In VLAN mode, the lookup process starts with VLAN Table lookup to determine whether the VID is valid. If the VID is not valid, the packet will be dropped and its address will not be learned. If the VID is valid, the FID is retrieved for further lookup. The FID + Destination Address (FID+DA) are used to determine the destination port. The FID + Source Address (FID+SA) are used for address learning.

DA found in Static MAC Table?	Use FID flag?	FID match?	DA+FID found in Dynamic MAC Table?	Action
No	Don't care	Don't care	No	Broadcast to the membership ports defined in the <i>VLAN Table</i> bits [18:16]
No	Don't care	Don't care	Yes	Send to the destination port defined in the <i>Dynamic MAC Address Table</i> bits [53:52]
Yes	0	Don't care	Don't care	Send to the destination port(s) defined in the <i>Static MAC Address Table</i> bits [50:48]
Yes	1	No	No	Broadcast to the membership ports defined in the <i>VLAN Table</i> bits [18:16]
Yes	1	No	Yes	Send to the destination port defined in the <i>Dynamic MAC Address Table</i> bits [53:52]
Yes	1	Yes	Don't care	Send to the destination port(s) defined in the <i>Static MAC Address Table</i> bits [50:48]

Table 9. FID+DA Lookup in VLAN Mode

FID+SA found in Dynamic MAC Table?	Action
No	Learn and add FID+SA to the Dynamic MAC Address Table
Yes	Update time stamp

Table 10. FID+SA Lookup in VLAN Mode

Advanced VLAN features, such as “Ingress VLAN filtering” and “Discard Non PVID packets” are also supported by the KS8993M. These features can be set on a per port basis, and are defined in register 18, bit 6 and bit 5, respectively for port 1.

QoS Priority Support

This feature provides Quality of Service (QoS) for applications, such as VoIP and video conferencing. The KS8993M per port transmit queue could be split into two priority queues: a high priority queue and a low priority queue. Bit 0 of registers 16, 32 and 48 is used to enable split transmit queues for ports 1, 2 and 3, respectively. Optionally, the Px_TXQ2 strap-in pins can be used to enable this feature. With split transmit queues, high priority packets will be placed in the high priority queue and low priority packets will be placed in the low priority queue.

For split transmit queues, the KS8993M provides four priority schemes:

1. “Transmit all high priority packets before low priority packets;” i.e. a low priority packet could be transmitted only when the high priority queue is empty
2. “Transmit high priority packets and low priority packets at 10:1 ratio;” i.e. transmit a low priority packet after every 10 high priority packets are transmitted, if both queues are busy
3. “Transmit high priority packets and low priority packets at 5:1 ratio”
4. “Transmit high priority packets and low priority packets at 2:1 ratio”

If a port's transmit queue is not split, both high priority packets and low priority packets have equal priority in the transmit queue. Register 5 bits [3:2] are used to select the desired priority scheme. Optionally, the PRSEL1 and PRSEL0 strap-in pins can be used.

Port-Based Priority

With port based priority, each ingress port can be individually classified as a high priority receiving port. All packets received at the high priority receiving port are marked as high priority, and will be sent to the high priority transmit queue if the corresponding transmit queue is split. Bit 4 of registers 16, 32 and 48 is used to enable port based priority for ports 1, 2 and 3, respectively. Optionally, the Px_PP strap-in pins can be used to enable this feature.

802.1p-Based Priority

For 802.1p based priority, the KS8993M will examine the ingress (incoming) packets to determine whether they are tagged. If tagged, the 3-bits priority field in the VLAN tag is retrieved and compared against the “priority base” value, specified by register 2 bits [6:4]. The “priority base” value is programmable; its default value is 0x4.

The following figure illustrates how the 802.1p priority field is embedded in the 802.1Q VLAN tag.

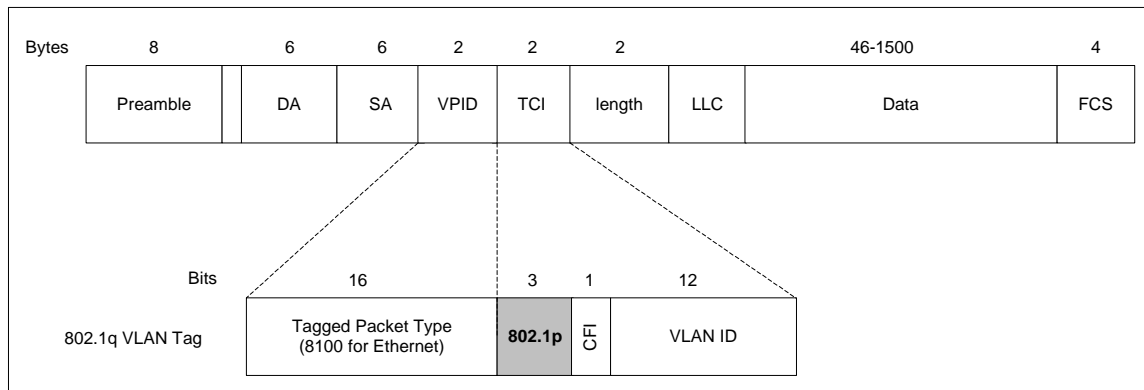

Figure 6. 802.1p Priority Field Format

If an ingress packet has an equal or higher priority value than the "priority base" value, the packet will be placed in the high priority transmit queue if the corresponding transmit queue is split. 802.1p based priority is enabled by bit 5 of registers 16, 32 and 48 for ports 1, 2 and 3, respectively. Optionally, the Px_1PEN strap-in pins can be used to enable this feature.

The KS8993M provides the option to insert or remove the priority tagged frame's header at each individual egress port. This header, consisting of the 2 bytes VLAN Protocol ID (VPID) and the 2 bytes Tag Control Information field (TCI), is also refer to as the 802.1Q VLAN Tag.

Tag Insertion is enabled by bit 2 of registers 16, 32 and 48 for ports 1, 2 and 3, respectively. Optionally, the Px_TAGINS strap-in pins can be used to enable this feature. At the egress port, untagged packets are tagged with the ingress port’s default tag. The default tags are programmed in register sets {19,20}, {35,36} and {51,52} for ports 1, 2 and 3, respectively. The KS8993M will not add tags to already tagged packets.

Tag Removal is enabled by bit 1 of registers 16, 32 and 48 for ports 1, 2 and 3, respectively. Optionally, the Px_TAGRM strap-in pins can be used to enable this feature. At the egress port, tagged packets will have their 802.1Q VLAN Tags removed. The KS8993M will not modify untagged packets.

The CRC is recalculated for both tag insertion and tag removal.

802.1p Priority Field Re-mapping is a QoS feature that allows the KS8993M to set the “User Priority Ceiling” at any ingress port. If the ingress packet’s priority field has a higher priority value than the default tag’s priority field of the ingress port, the packet’s priority field is replaced with the default tag’s priority field. The “User Priority Ceiling” is enabled by bit 3 of registers 16, 32 and 48 for ports 1, 2 and 3, respectively.

DiffServ-Based Priority

DiffServ-based priority uses registers 96 to 103. More details are provided at the beginning of the Advanced Control Registers section.

Rate Limiting Support

The KS8993M supports hardware rate limiting independently on the “receive side” and on the “transmit side” on a per port basis. Rate limiting is supported in both priority and non-priority environment. The rate limit starts from 0 kbps and goes up to the line rate in steps of 32 kbps. The KS8993M uses “one second” as the rate limiting interval. At the beginning of each interval, the counter is cleared to zero, and the rate limit mechanism starts to count the number of bytes during the interval.

On the “receive side”, if the number of bytes exceeds the programmed limit, the switch will stop receiving packets on the port until the “one second” interval expires. Flow control can be enabled to prevent packet loss. If the rate limit is programmed greater than or equal to 128 kbps and the byte counter is 8 Kbytes below the limit, flow control will be triggered. If the rate limit is programmed lower than 128 kbps and the byte counter is 2 Kbytes below the limit, flow control will also be triggered.

On the “transmit side”, if the number of bytes exceeds the programmed limit, the switch will stop transmitting packets on the port until the “one second” interval expires.

If priority is enabled, the KS8993M can be programmed to support different rate limits for high priority packets and low priority packets.

Configuration Interface

The KS8993M can operate as both a managed switch and an unmanaged switch.

In unmanaged mode, the KS8993M is typically programmed using an EEPROM. If no EEPROM is present, the KS8993M is configured using its default register settings. Some defaults settings are configured via strap-in pin options. The strap-in pins are indicated in the “KS8993M Pin Description and I/O Assignment” table.

I²C Master Serial Bus Configuration

With an additional I²C (“2-wire”) EEPROM, the KS8993M can perform more advanced switch features like “broadcast storm protection” and “rate control” without the need of an external processor.

For KS8993M I²C Master configuration, the EEPROM stores the configuration data for register 0 to register 109 (as defined in the KS8993M register map) with the exception of the “Read Only” status registers. After the de-assertion of reset, the KS8993M will sequentially read in the configuration data for all 110 registers, starting from register 0. The configuration access time (t_{prgm}) is less than 15 ms, as depicted in the following figure.

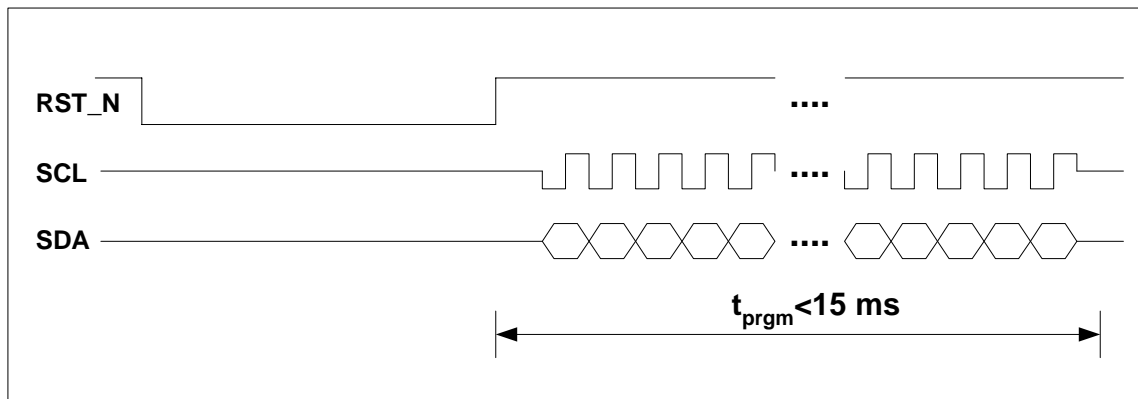

Figure 7. KS8993M EEPROM Configuration Timing Diagram

The following is a sample procedure for programming the KS8993M with a pre-configured EEPROM:

1. Connect the KS8993M to the EEPROM by joining the SCL and SDA signals of the respective devices. For the KS8993M, SCL is pin 97 and SDA is pin 98.

2. Enable I²C master mode by setting the KS8993M strap-in pins, PS[1:0] (pins 100 and 101, respectively) to "00".
3. Check to ensure that the KS8993M reset signal input, RST_N (pin 67), is properly connected to the external reset source at the board level.
4. Program the desired configuration data into the EEPROM.
5. Place the EEPROM on the board and power up the board.
6. Assert an active-low reset to the RST_N pin of the KS8993M. After reset is de-asserted, the KS8993M will begin reading the configuration data from the EEPROM. The KS8993M will check that the first byte read from the EEPROM is "93". If this value is correct, EEPROM configuration will continue. If not, EEPROM configuration access is denied and all other data sent from the EEPROM will be ignored by the KS8993M. The configuration access time (t_{prgm}) is less than 15ms.

Note: For proper operation, check to ensure that the KS8993M PWRDN input signal (pin 36) is not asserted during the reset operation. The PWRDN input is active low.

I²C Slave Serial Bus Configuration

In managed mode, the KS8993M can be configured as an I²C slave device. In this mode, an I²C master device (external controller/CPU) has complete programming access to the KS8993M's 128 registers. Programming access includes the Global Registers, Port Registers, Advanced Control Registers and indirect access to the "Static MAC Table", "VLAN Table", "Dynamic MAC Table," and "MIB Counters." The tables and counters are indirectly accessed via registers 110 thru 120.

In I²C slave mode, the KS8993M operates like other I²C slave devices. Addressing the KS8993M's 8 bit registers is similar to addressing Atmel's AT24C02 EEPROM's memory locations. Details of I²C read/write operations and related timing information can be found in the AT24C02 Datasheet.

Two fixed 8 bits device addresses are used to address the KS8993M in I²C slave mode. One is for read; the other is for write. The addresses are as follow:

1011_1111 <read>

1011_1110 <write>

The following is a sample procedure for programming the KS8993M using the I²C slave serial bus:

1. Enable I²C slave mode by setting the KS8993M strap-in pins PS[1:0] (pins 100 and 101, respectively) to "01".
2. Power up the board and assert reset to the KS8993M. After reset, the "Start Switch" bit (register 1 bit 0) will be set to '0'.
3. Configure the desired register settings in the KS8993M, using the I²C write operation.
4. Read back and verify the register settings in the KS8993M, using the I²C read operation.
5. Write a '1' to the "Start Switch" bit to start the KS8993M with the programmed settings.

Note: The "Start Switch" bit cannot be set to '0' to stop the switch after an '1' is written to this bit. Thus, it is recommended that all switch configuration settings are programmed before the "Start Switch" bit is set to '1'.

Some of the configuration settings, such as "Aging enable", "Auto Negotiation Enable", "Force Speed" and "Power down" can be programmed after the switch has been started.

SPI Slave Serial Bus Configuration

In managed mode, the KS8993M can be configured as a SPI slave device. In this mode, a SPI master device (external controller/CPU) has complete programming access to the KS8993M's 128 registers. Programming access includes the Global Registers, Port Registers, Advanced Control Registers and indirect access to the "Static MAC Table", "VLAN Table", "Dynamic MAC Table" and "MIB Counters". The tables and counters are indirectly accessed via registers 110 thru 120.

The KS8993M supports two standard SPI commands: '0000_0011' for data read and '0000_0010' for data write. SPI multiple read and multiple write are also supported by the KS8993M to expedite register read back and register configuration, respectively.

SPI multiple read is initiated when the master device continues to drive the KS8993M SPIS_N input pin (SPI Slave Select signal) low after a byte (a register) is read. The KS8993M internal address counter will increment automatically to the next byte (next register) after the read. The next byte at the next register address will be shifted out onto the KS8993M SPIQ output pin. SPI multiple read will continue until the SPI master device terminates it by de-asserting the SPIS_N signal to the KS8993M.

Similarly, SPI multiple write is initiated when the master device continues to drive the KS8993M SPIS_N input pin low after a byte (a register) is written. The KS8993M internal address counter will increment automatically to the next byte (next register) after the write. The next byte that is sent from the master device to the KS8993M SDA input pin will be written to the next register address. SPI multiple write will continue until the SPI master device terminates it by de-asserting the SPIS_N signal to the KS8993M.

For both SPI multiple read and multiple write, the KS8993M internal address counter will wrap back to register address zero once the highest register address is reached. This feature allows all 128 KS8993M registers to be read, or written with a single SPI command and any initial register address.

The KS8993M is capable of supporting a 5MHz SPI bus.

The following is a sample procedure for programming the KS8993M using the SPI bus:

1. At the board level, connect the KS8993M pins as follows:

KS8993M Pin #	KS8993M Signal Name	External Processor Signal Description
99	SPIS_N	SPI Slave Select
97	SCL (SPIC)	SPI Clock
98	SDA (SPID)	SPI Data (Master output; Slave input)
96	SPIQ	SPI Data (Master input; Slave output)

Table 11. KS8993M SPI Connections

2. Enable SPI slave mode by setting the KS8993M strap-in pins PS[1:0] (pins 100 and 101, respectively) to "10".
3. Power up the board and assert reset to the KS8993M.
After reset, the "Start Switch" bit (register 1 bit 0) will be set to '0'.
4. Configure the desired register settings in the KS8993M, using the SPI write or multiple write command.
5. Read back and verify the register settings in the KS8993M, using the SPI read or multiple read command.
6. Write a '1' to the "Start Switch" bit to start the KS8993M with the programmed settings.

Note: The "Start Switch" bit cannot be set to '0' to stop the switch after an '1' is written to this bit. Thus, it is recommended that all switch configuration settings are programmed before the "Start Switch" bit is set to '1'.

Some of the configuration settings, such as "Aging enable", "Auto Negotiation Enable", "Force Speed" and "Power down" can be programmed after the switch has been started.

The following four figures illustrate the SPI data cycles for "Write", "Read", "Multiple Write" and "Multiple Read". The read data is registered out of SPIQ on the falling edge of SPIC, and the data input on SPID is registered on the rising edge of SPIC.

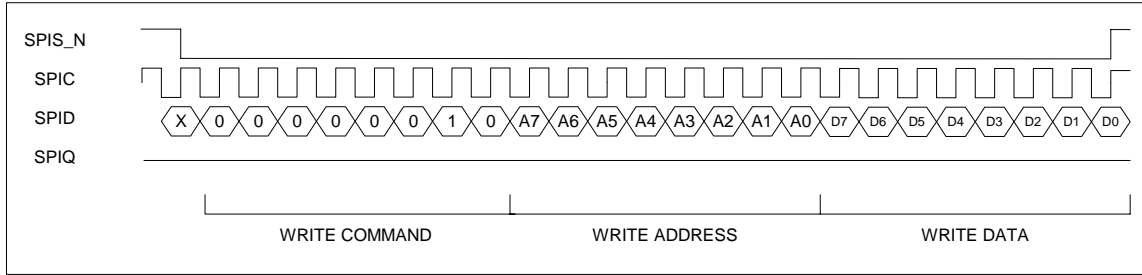

Figure 8. SPI Write Data Cycle

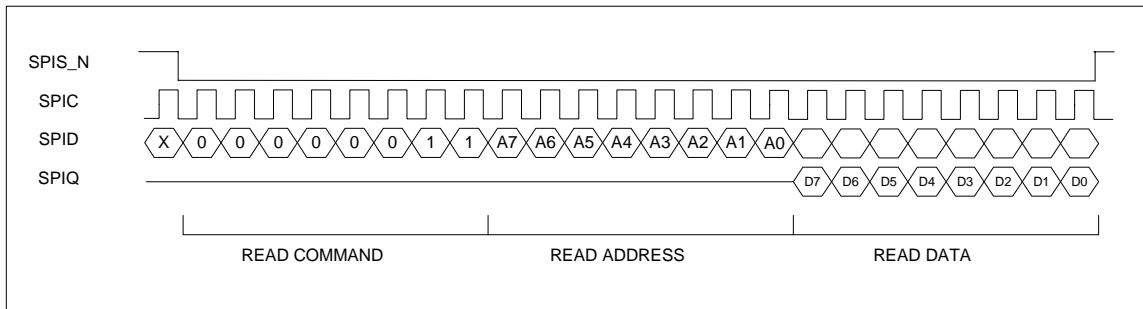

Figure 9. SPI Read Data Cycle

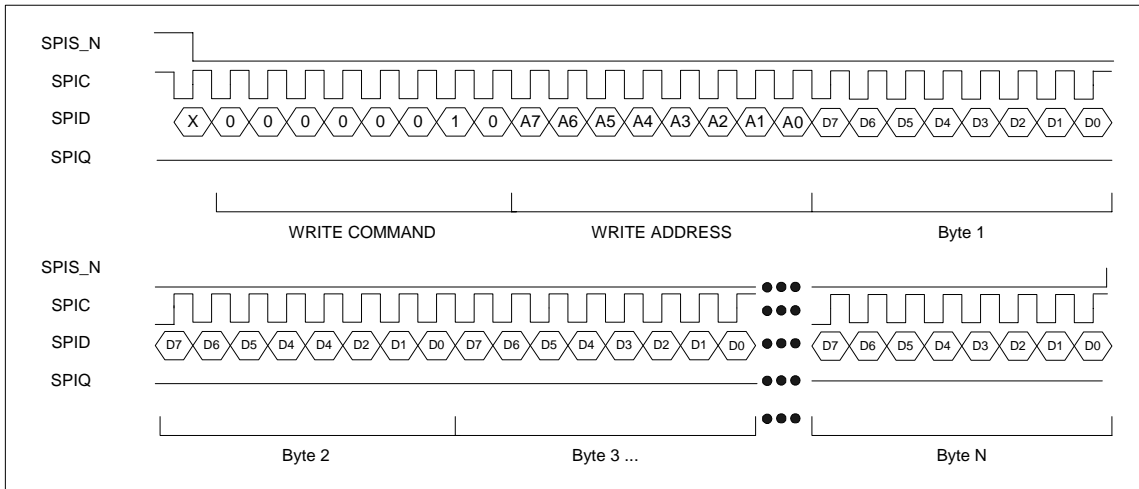

Figure 10. SPI Multiple Write

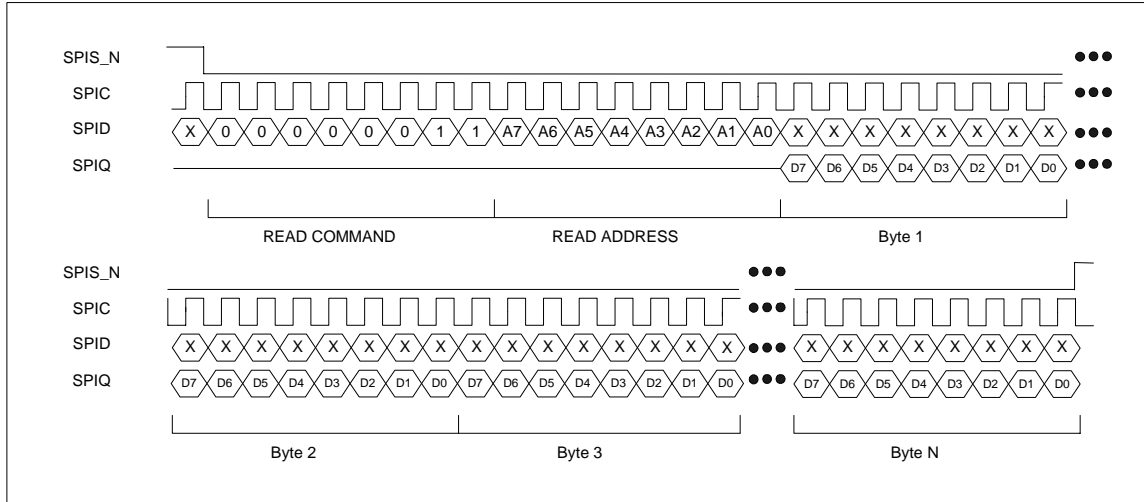

Figure 11. SPI Multiple Read

Loopback Support

The KS8993M provides loopback support for remote diagnostic of failure. In loopback mode, the speed at both PHY ports needs to be set to 100BASE-TX, and the “Priority Buffer reserve” bit needs to be set to 48 pre-allocated buffers per output queue. The latter is required to prevent loopback packet drops and is achieved by setting register 4 bit 0 to ‘1’.

Bit 0 of registers 29 and 45 is used to enable loopback for ports 1 and 2, respectively.

Alternatively, the MII Management register 0, bit 14 can be used to enable loopback.

Loopback is conducted between the KS8993M’s two PHY ports. The loopback path starts at the “Originating.” PHY ports receive inputs (RXP/RXM), wraps around at the “loopback” PHY port’s PMD/PMA, and ends at the “Originating” PHY port’s transmit outputs (TXP/TXM). The KS8993M loopback path is illustrated in the following figure.

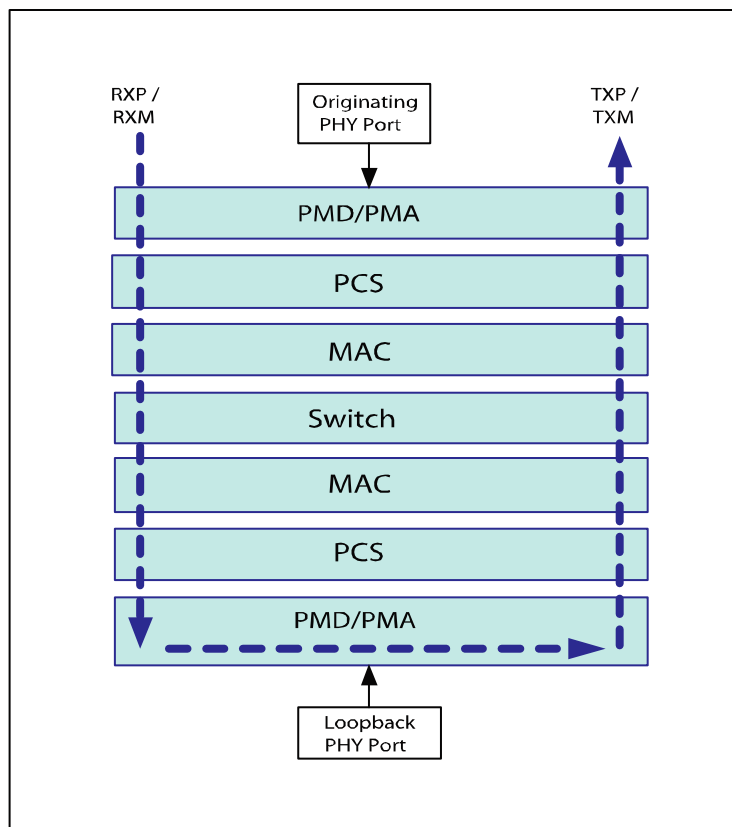

Figure 12. Loopback Path

MII Management (MIIM) Registers

The MIIM interface is used to access the MII PHY registers defined in this section. The SPI, I²C, and SMI interfaces can also be used to access these registers. The latter three interfaces use a different mapping mechanism than the MIIM interface.

As defined in the IEEE 802.3 specification, the “PHYAD” are assigned as “0x1” for PHY port 1 and “0x2” for PHY port 2. The “REGAD” supported are 0,1,2,3,4, and 5.

Register Number	Description
0x0	Basic Control Register
0x1	Basic Status Register
0x2	Physical Identifier I
0x3	Physical Identifier II
0x4	Auto-Negotiation Advertisement Register
0x5	Auto-Negotiation Link Partner Ability Register
0x6 – 0x1F	Not supported

Register 0: MII Basic Control

Bit	Name	R/W	Description	Default	Reference
15	Soft reset	RO	NOT SUPPORTED	0	
14	Loopback	R/W	=1, Loopback mode =0, Normal operation	0	Reg. 29, bit 0 Reg. 45, bit 0
13	Force 100	R/W	=1, 100 Mbps =0, 10 Mbps	0	Reg. 28, bit 6 Reg. 44, bit 6
12	AN enable	R/W	=1, Auto-negotiation enabled =0, Auto-negotiation disabled	1	
11	Power down	R/W	=1, Power down =0, Normal operation	0	Reg. 29, bit 3 Reg. 45, bit 3
10	Isolate	RO	NOT SUPPORTED	0	
9	Restart AN	R/W	=1, Restart auto-negotiation =0, Normal operation	0	Reg. 29, bit 5 Reg. 45, bit 5
8	Force full duplex	R/W	=1, Full duplex =0, Half duplex	0	Reg. 28, bit 5 Reg. 44, bit 5
7	Collision test	RO	NOT SUPPORTED	0	
6	Reserved	RO		0	
5	Reserved	RO		0	
4	Force MDI	R/W	=1, Force MDI (transmit on RXP / RXM pins) =0, Normal operation (transmit on TXP / TXM pins)	0	Reg. 29, bit 1 Reg. 45, bit 1

Register 0: MII Basic Control (continued)

Bit	Name	R/W	Description	Default	Reference
3	Disable MDIX	R/W	=1, Disable auto MDI-X =0, Normal operation	0	Reg. 29, bit 2 Reg. 45, bit 2
2	Disable far end fault	R/W	=1, Disable far end fault detection =0, Normal operation	0	Reg. 29, bit 4
1	Disable transmit	R/W	=1, Disable transmit =0, Normal operation	0	Reg. 29, bit 6 Reg. 45, bit 6
0	Disable LED	R/W	=1, Disable LED =0, Normal operation	0	Reg. 29, bit 7 Reg. 45, bit 7

Register 1: MII Basic Status

Bit	Name	R/W	Description	Default	Reference
15	T4 capable	RO	=0, Not 100 BASE-T4 capable	0	
14	100 Full capable	RO	=1, 100BASE-TX full duplex capable =0, Not capable of 100BASE-TX full duplex	1	Always 1
13	100 Half capable	RO	=1, 100BASE-TX half duplex capable =0, Not 100BASE-TX half duplex capable	1	Always 1
12	10 Full capable	RO	=1, 10BASE-T full duplex capable =0, Not 10BASE-T full duplex capable	1	Always 1
11	10 Half capable	RO	=1, 10BASE-T half duplex capable =0, Not 10BASE-T half duplex capable	1	Always 1
10-7	Reserved	RO		0	
6	Preamble suppressed	RO	NOT SUPPORTED	0	
5	AN complete	RO	=1, Auto-negotiation complete =0, Auto-negotiation not completed	0	Reg. 30, bit 6 Reg. 46, bit 6
4	Far end fault	RO	=1, Far end fault detected =0, No far end fault detected	0	Reg. 31, bit 0
3	AN capable	RO	=1, Auto-negotiation capable =0, Not auto-negotiation capable	1	Reg. 28, bit 7 Reg. 44, bit 7
2	Link status	RO	=1, Link is up =0, Link is down	0	Reg. 30, bit 5 Reg. 46, bit 5
1	Jabber test	RO	NOT SUPPORTED	0	
0	Extended capable	RO	=0, Not extended register capable	0	

Register 2: PHYID HIGH

Bit	Name	R/W	Description	Default
15-0	PHYID high	RO	High order PHYID bits	0x0022

Register 3: PHYID LOW

Bit	Name	R/W	Description	Default
15-0	PHYID low	RO	Low order PHYID bits	0x1430

Register 4: Auto-Negotiation Advertisement Ability

Bit	Name	R/W	Description	Default	Reference
15	Next page	RO	NOT SUPPORTED	0	
14	Reserved	RO		0	
13	Remote fault	RO	NOT SUPPORTED	0	
12-11	Reserved	RO		0	
10	Pause	R/W	=1, Advertise pause ability =0, Do not advertise pause ability	1	Reg. 28, bit 4 Reg. 44, bit 4
9	Reserved	R/W		0	
8	Adv 100 Full	R/W	=1, Advertise 100 full duplex ability =0, Do not advertise 100 full duplex ability	1	Reg. 28, bit 3 Reg. 44, bit 3
7	Adv 100 Half	R/W	=1, Advertise 100 half duplex ability =0, Do not advertise 100 half duplex ability	1	Reg. 28, bit 2 Reg. 44, bit 2
6	Adv 10 Full	R/W	=1, Advertise 10 full duplex ability =0, Do not advertise 10 full duplex ability	1	Reg. 28, bit 1 Reg. 44, bit 1
5	Adv 10 Half	R/W	=1, Advertise 10 half duplex ability =0, Do not advertise 10 half duplex ability	1	Reg. 28, bit 0 Reg. 44, bit 0
4-0	Selector field	RO	802.3	00001	

Register 5: Auto-Negotiation Link Partner Ability

Bit	Name	R/W	Description	Default	Reference
15	Next page	RO	NOT SUPPORTED	0	
14	LP ACK	RO	NOT SUPPORTED	0	
13	Remote fault	RO	NOT SUPPORTED	0	
12-11	Reserved	RO		0	
10	Pause	RO	Link partner pause capability	0	Reg. 30, bit 4 Reg. 46, bit 4
9	Reserved	RO		0	
8	Adv 100 Full	RO	Link partner 100 full capability	0	Reg. 30, bit 3 Reg. 46, bit 3
7	Adv 100 Half	RO	Link partner 100 half capability	0	Reg. 30, bit 2 Reg. 46, bit 2
6	Adv 10 Full	RO	Link partner 10 full capability	0	Reg. 30, bit 1 Reg. 46, bit 1
5	Adv 10 Half	RO	Link partner 10 half capability	0	Reg. 30, bit 0 Reg. 46, bit 0
4-0	Reserved	RO		00000	

Register Map: Switch & PHY (8 bit registers)

Global Registers

Register (Decimal)	Register (Hex0)	Description
0-1	0x00-0x01	Chip ID Registers
2-11	0x02-0x0B	Global Control Registers
12	0x0C	Reserved Register
13-15	0x0D-0x0F	User Defined Registers

Port Registers

Register (Decimal)	Register (Hex0)	Description
16-29	0x10-0x1D	Port 1 Control Registers, including MII PHY Registers
30-31	0x1E-0x1F	Port 1 Status Registers, including MII PHY Registers
32-45	0x20-0x2D	Port 2 Control Registers, including MII PHY Registers
46-47	0x2E-0x2F	Port 2 Status Registers, including MII PHY Registers
48-61	0x30-0x3D	Port 3 Control Registers, including MII PHY Registers
62-63	0x3E-0x3F	Port 3 Status Registers, including MII PHY Registers
64-95	0x40-0x5F	Reserved

Advanced Control Registers

Register (Decimal)	Register (Hex0)	Description
96-103	0x60-0x67	TOS Priority Control Registers
104-109	0x68-0x6D	Switch Engine's MAC Address Registers
110-111	0x6E-0x6F	Indirect Access Control Registers
112-120	0x70-0x78	Indirect Data Registers
121-122	0x79-0x7A	Digital Testing Status Registers
123-124	0x7B-0x7C	Digital Testing Control Registers
125-126	0x7D-0x7E	Analog Testing Control Registers
127	0x7F	Analog Testing Status Register

Global Registers

Register 0 (0x00): Chip ID0

Bit	Name	R/W	Description	Default
7-0	Family ID	RO	Chip family	0x93

Register 1 (0x01): Chip ID1 / Start Switch

Bit	Name	R/W	Description	Default
7-4	Chip ID	RO	0x0 is assigned to M series. (93M)	0x0
3-1	Revision ID	RO	Revision ID	-
0	Start switch	RW	<p>= 1, start the chip when external pins (PS1, PS0) = (0,1) or (1,0) or (1,1).</p> <p>Note: In (PS1, PS0) = (0, 0) mode, the chip will start automatically after trying to read the external EEPROM. If EEPROM does not exist, the chip will use pin strapping and default values for all internal registers. If EEPROM is present, the contents in the EEPROM will be checked. The switch will check: (1) Register 0 = 0x93, (2) Register 1 bits [7:4] = 0x0. If this check is OK, the contents in the EEPROM will override chip registers' default values.</p> <p>= 0, chip will not start when external pins (PS1, PS0) = (0,1) or (1,0) or (1,1).</p>	-

Register 2 (0x02): Global Control 0

Bit	Name	R/W	Description	Default
7	New back-off Enable	R/W	<p>New back-off algorithm designed for UNH</p> <p>1 = Enable</p> <p>0 = Disable</p>	0x0
6-4	802.1p base priority	R/W	<p>Used to classify priority for incoming 802.1Q packets. "user priority" is compared against this value.</p> <p>>= : classified as high priority</p> <p>< : classified as low priority</p>	0x4
3	Pass flow control packet	R/W	= 1, switch will not filter 802.1x "flow control" packets	0x0
2	Buffer share mode	R/W	<p>= 1, buffer pool is shared by all ports. A port can use more buffers when other ports are not busy.</p> <p>= 0, a port is only allowed to use 1/3 of the buffer pool.</p>	0x1
1	Reserved	R/W	Reserved	0
0	Link change age	R/W	<p>= 1, link change from "link" to "no link" will cause fast aging (<800us) to age address table faster. After an age cycle is complete, the age logic will return to normal aging (about 200 sec).</p> <p>Note: If any port is unplugged, all addresses will be automatically aged out.</p>	0

Register 3 (0x03): Global Control 1

Bit	Name	R/W	Description	Default
7	Pass all frames	R/W	= 1, switch all packets including bad ones. Used solely for debugging purposes. Works in conjunction with sniffer mode only.	0
6	Repeater mode	R/W	0 = normal mode 1 = repeater mode (half duplex Hub mode)	0
5	IEEE 802.3x Transmit direction flow control enable	R/W	= 1, will enable transmit direction flow control feature. = 0, will not enable transmit direction flow control feature.	1
4	IEEE 802.3x Receive direction flow control enable	R/W	= 1, will enable receive direction flow control feature. = 0, will not enable receive direction flow control feature.	1
3	Frame Length field check	R/W	1 = will check frame length field in the IEEE packets. If the actual length does not match, the packet will be dropped (for Length/Type field < 1500).	0
2	Aging enable	R/W	1 = enable age function in the chip 0 = disable age function in the chip	1
1	Fast age enable	R/W	1 = turn on fast age (800us)	0
0	Aggressive back off enable	R/W	1 = enable more aggressive back off algorithm in half duplex mode to enhance performance. This is not an IEEE standard.	SMAC (pin 69) value during reset.

Register 4 (0x04): Global Control 2

Bit	Name	R/W	Description	Default
7	Unicast port-VLAN mismatch discard	R/W	This feature is used for port-VLAN (described in reg. 17, reg. 33, ...) = 1, all packets can not cross VLAN boundary = 0, unicast packets (excluding unknown/multicast/broadcast) can cross VLAN boundary Note: Port mirroring is not supported if this bit is set to "0".	1
6	Multicast storm protection disable	R/W	= 1, "Broadcast Storm Protection" does not include multicast packets. Only DA = FFFFFFFF packets will be regulated. = 0, "Broadcast Storm Protection" includes DA = FFFFFFFF and DA[40] = 1 packets.	1
5	Back pressure Mode	R/W	= 1, carrier sense based backpressure is selected = 0, collision based backpressure is selected	1

Register 4 (0x04): Global Control 2 (continued)

Bit	Name	R/W	Description	Default
4	Flow control and back pressure fair mode	R/W	<p>= 1, fair mode is selected. In this mode, if a flow control port and a non-flow control port talk to the same destination port, packets from the non-flow control port may be dropped. This is to prevent the flow control port from being flow controlled for an extended period of time.</p> <p>= 0, in this mode, if a flow control port and a non-flow control port talk to the same destination port, the flow control port will be flow controlled. This may not be "fair" to the flow control port.</p>	1
3	No excessive collision drop	R/W	<p>= 1, the switch will not drop packets when 16 or more collisions occur.</p> <p>= 0, the switch will drop packets when 16 or more collisions occur.</p>	SMAC (pin 69) value during reset.
2	Huge packet support	R/W	<p>= 1, will accept packet sizes up to 1916 bytes (inclusive). This bit setting will override setting from bit 1 of the same register.</p> <p>= 0, the max packet size will be determined by bit 1 of this register.</p>	0
1	Legal Maximum Packet size check enable	R/W	<p>= 0, will accept packet sizes up to 1536 bytes (inclusive).</p> <p>= 1, 1522 bytes for tagged packets, 1518 bytes for untagged packets. Any packets larger than the specified value will be dropped.</p>	SMRXD0 (pin 85) value during reset.
0	Priority Buffer reserve	R/W	<p>= 1, each output queue is pre-allocated 48 buffers, used exclusively for high priority packets. It is recommended to enable this when priority queue feature is turned on.</p> <p>= 0, no reserved buffers for high priority packets.</p>	1

Register 5 (0x05): Global Control 3

Bit	Name	R/W	Description	Default
7	802.1Q VLAN enable	R/W	<p>= 1, 802.1Q VLAN mode is turned on. VLAN table needs to set up before the operation.</p> <p>= 0, 802.1Q VLAN is disabled.</p>	0
6	IGMP snoop enable on Switch MII interface	R/W	<p>=1, IGMP snoop is enabled.</p> <p>All the IGMP packets will be forwarded to the Switch MII port.</p> <p>=0, IGMP snoop is disabled.</p>	0
5	Reserved	R/W		0
4	Reserved	R/W		0
3-2	Priority Scheme select	R/W	<p>00 = always deliver high priority packets first</p> <p>01 = deliver high/low packets at ratio 10/1</p> <p>10 = deliver high/low packets at ratio 5/1</p> <p>11 = deliver high/low packets at ratio 2/1</p>	00
1	Reserved	R/W		0

Register 5 (0x05): Global Control 3 (continued)

Bit	Name	R/W	Description	Default
0	Sniff mode select	R./W	= 1, will do rx AND tx sniff (both source port and destination port need to match) = 0, will do rx OR tx sniff (Either source port or destination port needs to match). This is the mode used to implement rx only sniff.	0

Register 6 (0x06): Global Control 4

Bit	Name	R/W	Description	Default
7	Reserved	R/W		0
6	Switch MII half-duplex mode	R/W	= 1, enable MII interface half-duplex mode. = 0, enable MII interface full-duplex mode.	Pin SMRXD2 strap option. Pull-down(0): Full-duplex mode Pull-up(1): Half-duplex mode Note: SMRXD2 has internal pull-down.
5	Switch MII flow control enable	R/W	= 1, enable full-duplex flow control on Switch MII interface. = 0, disable full-duplex flow control on Switch MII interface.	Pin SMRXD3 strap option. Pull-down(0): Disable flow control Pull-up(1): Enable flow control Note: SMRXD3 has internal pull-down.
4	Switch MII 10BT	R/W	= 1, the switch interface is in 10Mbps mode = 0, the switch interface is in 100Mbps mode	Pin SMRXD1 strap option. Pull-down(0): Enable 100Mbps Pull-up(1): Enable 10Mbps Note: SMRXD1 has internal pull-down.

Register 6 (0x06): Global Control 4 (continued)

Bit	Name	R/W	Description	Default
3	Null VID replacement	R/W	= 1, will replace NULL VID with port VID(12 bits) = 0, no replacement for NULL VID	0
2-0	Broadcast storm protection rate Bit [10:8]	R/W	This register along with the next register determines how many "64 byte blocks" of packet data allowed on an input port in a preset period. The period is 50ms for 100BT or 500ms for 10BT. The default is 1%.	000

Register 7 (0x07): Global Control 5

Bit	Name	R/W	Description	Default
7-0	Broadcast storm protection rate ⁽¹⁾ Bit [7:0]	R/W	This register along with the previous register determines how many "64 byte blocks" of packet data are allowed on an input port in a preset period. The period is 67ms for 100BT or 500ms for 10BT. The default is 1%.	0x63

Note: Rate: 148,800 frames/sec * 67 ms/interval * 1% = 99 frames/interval (approx.) = 0x63

Register 8 (0x08): Global Control 6

Bit	Name	R/W	Description	Default
7-0	Factory testing	R/W	Reserved	0x4E

Register 9 (0x09): Global Control 7

Bit	Name	R/W	Description	Default
7-0	Factory testing	R/W	Reserved	0x24

Register 10 (0x0A): Global Control 8

Bit	Name	R/W	Description	Default
7-0	Factory testing	R/W	Reserved	0x24

Register 11 (0x0B): Global Control 9

Bit	Name	R/W	Description	Default
7	Reserved		Reserved	0
6	PHY power save	R/W	= 1, enable PHY power save mode = 0, disable PHY power save mode	0
5	Reserved	R/W	Reserved	0
4	Reserved	RW	Testing mode, must be 0	0
3	Reserved	R/W	Reserved	1

Register 11 (0x0B): Global Control 9 (continued)

Bit	Name	R/W	Description	Default																																				
2	Reserved	R/W	Reserved	0																																				
1	LED mode	R/W	<p>This register bit sets the LEDSEL0 selection only. LEDSEL1 is set via strap-in pin.</p> <p>Port x LED indicators, defined as below:</p> <table border="1" style="margin-left: 40px;"> <thead> <tr> <th colspan="3">[LEDSEL1, LEDSEL0]</th> </tr> <tr> <th></th> <th>[0, 0]</th> <th>[0, 1]</th> </tr> </thead> <tbody> <tr> <td>PxLED3</td> <td>-----</td> <td>-----</td> </tr> <tr> <td>PxLED2</td> <td>LINK/ACT</td> <td>100LINK/ACT</td> </tr> <tr> <td>PxLED1</td> <td>FULL_DPX/COL</td> <td>10LINK/ACT</td> </tr> <tr> <td>PxLED0</td> <td>SPEED</td> <td>FULL_DPX</td> </tr> </tbody> </table> <table border="1" style="margin-left: 40px;"> <thead> <tr> <th colspan="3">[LEDSEL1, LEDSEL0]</th> </tr> <tr> <th></th> <th>[1, 0]</th> <th>[1, 1]</th> </tr> </thead> <tbody> <tr> <td>PxLED3</td> <td>ACT</td> <td>-----</td> </tr> <tr> <td>PxLED2</td> <td>LINK</td> <td>-----</td> </tr> <tr> <td>PxLED1</td> <td>FULL_DPX/COL</td> <td>-----</td> </tr> <tr> <td>PxLED0</td> <td>SPEED</td> <td>-----</td> </tr> </tbody> </table> <p>Notes: LEDSEL0 is external strap-in pin #70. LEDSEL1 is external strap-in pin #23.</p>	[LEDSEL1, LEDSEL0]				[0, 0]	[0, 1]	PxLED3	-----	-----	PxLED2	LINK/ACT	100LINK/ACT	PxLED1	FULL_DPX/COL	10LINK/ACT	PxLED0	SPEED	FULL_DPX	[LEDSEL1, LEDSEL0]				[1, 0]	[1, 1]	PxLED3	ACT	-----	PxLED2	LINK	-----	PxLED1	FULL_DPX/COL	-----	PxLED0	SPEED	-----	LEDSEL0 pin value during reset.
[LEDSEL1, LEDSEL0]																																								
	[0, 0]	[0, 1]																																						
PxLED3	-----	-----																																						
PxLED2	LINK/ACT	100LINK/ACT																																						
PxLED1	FULL_DPX/COL	10LINK/ACT																																						
PxLED0	SPEED	FULL_DPX																																						
[LEDSEL1, LEDSEL0]																																								
	[1, 0]	[1, 1]																																						
PxLED3	ACT	-----																																						
PxLED2	LINK	-----																																						
PxLED1	FULL_DPX/COL	-----																																						
PxLED0	SPEED	-----																																						
0	Special TPID mode	R/W	<p>Used for direct mode forwarding from port 3. See description in "spanning tree" functional description.</p> <p>0 = disable 1 = enable</p>	0																																				

Register 12 (0x0C): Reserved Register

Bit	Name	R/W	Description	Default
7-0	Reserved		Reserved	0x00

Register 13 (0x0D): User Defined Register 1

Bit	Name	R/W	Description	Default
7-0	UDR1	R/W		0x00

Register 14 (0x0E): User Defined Register 2

Bit	Name	R/W	Description	Default
7-0	UDR2	R/W		0x00

Register 15 (0x0F): User Defined Register 3

Bit	Name	R/W	Description	Default
7-0	UDR3	R/W		0x00

Port Registers

The following registers are used to enable features that are assigned on a per port basis. The register bit assignments are the same for all ports, but the address for each port is different, as indicated.

Register 16 (0x10): Port 1 Control 0

Register 32 (0x20): Port 2 Control 0

Register 48 (0x30): Port 3 Control 0

Bit	Name	R/W	Description	Default
7	Broadcast storm protection enable	R/W	= 1, enable broadcast storm protection for ingress packets on the port = 0, disable broadcast storm protection	0
6	DiffServ priority classification enable	R/W	= 1, enable DiffServ priority classification for ingress packets on port = 0, disable DiffServ function	0
5	802.1p priority classification enable	R/W	= 1, enable 802.1p priority classification for ingress packets on port = 0, disable 802.1p	Pin value during reset: P1_1PEN (port 1) P2_1PEN (port 2) P3_1PEN (port 3)
4	Port-based priority classification enable	R/W	= 1, ingress packets on the port will be classified as high priority if "DiffServ" or "802.1p" classification is not enabled or fails to classify. = 0, ingress packets on port will be classified as low priority if "DiffServ" or "802.1p" classification is not enabled or fails to classify. Note: "DiffServ", "802.1p" and port priority can be enabled at the same time. The OR'ed result of 802.1p and DSCP overwrites the port priority.	Pin value during reset: P1_PP (port 1) P2_PP (port 2) P3_PP (port 3)
3	User priority ceiling	R/W	= 1, if the packet's "user priority field" is greater than the "user priority field" in the port default tag register, replace the packet's "user priority field" with the "user priority field" in the port default tag register. = 0, do not compare and replace the packet's 'user priority field'	0
2	Tag insertion	R/W	= 1, when packets are output on the port, the switch will add 802.1p/q tags to packets without 802.1p/q tags when received. The switch will not add tags to packets already tagged. The tag inserted is the ingress port's "port VID". = 0, disable tag insertion	Pin value during reset: P1_TAGINS (port 1) P2_TAGINS (port 2) P3_TAGINS (port 3)

Register 16 (0x10): Port 1 Control 0**Register 32 (0x20): Port 2 Control 0****Register 48 (0x30): Port 3 Control 0 (continued)**

Bit	Name	R/W	Description	Default
1	Tag removal	R/W	= 1, when packets are output on the port, the switch will remove 802.1p/q tags from packets with 802.1p/q tags when received. The switch will not modify packets received without tags. = 0, disable tag removal	Pin value during reset: P1_TAGRM (port 1) P2_TAGRM (port 2) P3_TAGRM (port 3)
0	Priority enable	R/W	= 1, the port output queue is split into high and low priority queues. = 0, single output queue on the port. There is no priority differentiation even though packets are classified into high or low priority.	Pin value during reset: P1_TXQ2 (port 1) P2_TXQ2 (port 2) P3_TXQ2 (port 3)

Register 17 (0x11): Port 1 Control 1**Register 33 (0x21): Port 2 Control 1****Register 49 (0x31): Port 3 Control 1**

Bit	Name	R/W	Description	Default
7	Sniffer port	R/W	= 1, Port is designated as sniffer port and will transmit packets that are monitored. = 0, Port is a normal port	0
6	Receive sniff	R/W	= 1, All the packets received on the port will be marked as "monitored packets" and forwarded to the designated "sniffer port" = 0, no receive monitoring	0
5	Transmit sniff	R/W	= 1, All the packets transmitted on the port will be marked as "monitored packets" and forwarded to the designated "sniffer port" = 0, no transmit monitoring	0
4	Double tag	R/W	= 1, All packets will be tagged with port default tag of ingress port regardless of the original packets are tagged or not = 0, do not double tagged on all packets	0x0
3	Reserved	R/W		0x0
2-0	Port VLAN membership	R/W	Define the port's " egress port VLAN membership. Bit 2 stands for port 3, bit 1 for port 2 bit 0 for port 1. The Port can only communicate within the membership. A '1' includes a port in the membership, a '0' excludes a port from membership.	Pin value during reset: For port 1, (PV13, PV12, 1) For port 2, (PV23, 1, PV21) For port 3, (1, PV32, PV31)

Register 18 (0x12): Port 1 Control 2**Register 34 (0x22): Port 2 Control 2****Register 50 (0x32): Port 3 Control 2**

Bit	Name	R/W	Description	Default
7	Reserved		Reserved	0
6	Ingress VLAN filtering	R/W	= 1, the switch will discard packets whose VID port membership in VLAN table bits [18:16] does not include the ingress port. = 0, no ingress VLAN filtering.	0
5	Discard non PVID packets	R/W	= 1, the switch will discard packets whose VID does not match ingress port default VID. = 0, no packets will be discarded	0
4	Force flow control	R/W	= 1, will always enable flow control on the port, regardless of AN result. = 0, the flow control is enabled based on AN result.	Pin value during reset: For port 1, P1FFC pin For port 2, P2FFC pin For port 3, this bit has no meaning. Flow control is controlled by Reg. 6, bit 5.
3	Back pressure enable	R/W	= 1, enable port's half duplex back pressure = 0, disable port's half duplex back pressure.	Pin value during reset: BPEN pin
2	Transmit enable	R/W	= 1, enable packet transmission on the port = 0, disable packet transmission on the port	1
1	Receive enable	R/W	= 1, enable packet reception on the port = 0, disable packet reception on the port	1
0	Learning disable	R/W	= 1, disable switch address learning capability = 0, enable switch address learning	0

Note: Bits [2:0] are used for spanning tree support (see page 33).

Register 19 (0x13): Port 1 Control 3**Register 35 (0x23): Port 2 Control 3****Register 51 (0x33): Port 3 Control 3**

Bit	Name	R/W	Description	Default
7-0	Default tag [15:8]	R/W	Port's default tag, containing 7-5 : User priority bits 4 : CFI bit 3-0 : VID[11:8]	0x00

Register 20 (0x14): Port 1 Control 4**Register 36 (0x24): Port 2 Control 4****Register 52 (0x34): Port 3 Control 4**

Bit	Name	R/W	Description	Default
7-0	Default tag [7:0]	R/W	Port's default tag, containing 7-0: VID[7:0]	0x01

Note: Registers 19 and 20 (and those corresponding to other ports) serve two purposes:

1. Associated with the ingress untagged packets, and used for egress tagging.
2. Default VID for the ingress untagged or null-VID-tagged packets, and used for address lookup.

Register 21 (0x15): Port 1 Control 5**Register 37 (0x25): Port 2 Control 5****Register 53 (0x35): Port 3 Control 5**

Bit	Name	R/W	Description	Default
7-0	Transmit high priority rate control [7:0]	R/W	This register along with port control 7, bits [3:0] form a 12-bits field to determine how many "32Kbps" high priority blocks can be transmitted in a unit of 4Kbytes in a one second period).	0x00

Register 22 (0x16): Port 1 Control 6**Register 38 (0x26): Port 2 Control 6****Register 54 (0x36): Port 3 Control 6**

Bit	Name	R/W	Description	Default
7-0	Transmit low priority rate control [7:0]	R/W	This register along with port control 7, bits [7:4] form a 12-bits field to determine how many "32Kbps" low priority blocks can be transmitted in a unit of 4 Kbytes in a one second period).	0x00

Register 23 (0x17): Port 1 Control 7**Register 39 (0x27): Port 2 Control 7****Register 55 (0x37): Port 3 Control 7**

Bit	Name	R/W	Description	Default
7-4	Transmit low priority rate control [11:8]	R/W	These bits along with port control 6, bits [7:0] form a 12-bits field to determine how many "32Kbps" low priority blocks can be transmitted in a unit of 4Kbytes in a one second period).	0x0
3-0	Transmit high priority rate control [11:8]	R/W	These bits along with port control 5, bits [7:0] form a 12-bits field to determine how many "32Kbps" high priority blocks can be transmitted (in a unit of 4Kbytes in a one second period).	0x0

Register 24 (0x18): Port 1 Control 8**Register 40 (0x28): Port 2 Control 8****Register 56 (0x38): Port 3 Control 8**

Bit	Name	R/W	Description	Default
7-0	Receive high priority rate control [7:0]	R/W	This register along with port control 10, bits [3:0] form a 12-bits field to determine how many "32Kbps" high priority blocks can be received in a unit of 4Kbytes in a one second period).	0x00

Register 25 (0x19): Port 1 Control 9**Register 41 (0x29): Port 2 Control 9****Register 57 (0x39): Port 3 Control 9**

Bit	Name	R/W	Description	Default
7-0	Receive low priority rate control [7:0]	R/W	This register along with port control 10, bits [7:4] form a 12-bits field to determine how many "32Kbps" low priority blocks can be received (in a unit of 4Kbytes in a one second period).	0x00

Register 26 (0x1A): Port 1 Control 10**Register 42 (0x2A): Port 2 Control 10****Register 58 (0x3A): Port 3 Control 10**

Bit	Name	R/W	Description	Default
7-4	Receive low priority rate control [11:8]	R/W	These bits along with port control 9, bits [7:0] form a 12-bits field to determine how many "32Kbps" low priority blocks can be received (in a unit of 4Kbytes in a one second period).	0x0
3-0	Receive high priority rate control [11:8]	R/W	These bits along with port control 8, bits [7:0] form a 12-bits field to determine how many "32Kbps" high priority blocks can be received (in a unit of 4Kbytes in a one second period).	0x0

Register 27 (0x1B): Port 1 Control 11**Register 43 (0x2B): Port 2 Control 11****Register 59 (0x3B): Port 3 Control 11**

Bit	Name	R/W	Description	Default
7	Receive differential priority rate control	R/W	= 1, If bit 6 is also '1' this will enable receive rate control for this port on low priority packets at the low priority rate. If bit 5 is also '1', this will enable receive rate control on high priority packets at the high priority rate. = 0, receive rate control will be based on the low priority rate for all packets on this port.	0
6	Low priority receive rate control enable	R/W	= 1, enable port's low priority receive rate control feature = 0, disable port's low priority receive rate control	0
5	High priority receive rate control enable	R/W	= 1, If bit 7 is also '1' this will enable the port's high priority receive rate control feature. If bit 7 is a '0' and bit 6 is a '1', all receive packets on this port will be rate controlled at the low priority rate. = 0, disable port's high priority receive rate control feature	0
4	Low priority receive rate flow control enable	R/W	= 1, flow control may be asserted if the port's low priority receive rate is exceeded. = 0, flow control is not asserted if the port's low priority receive rate is exceeded.	0

Register 27 (0x1B): Port 1 Control 11**Register 43 (0x2B): Port 2 Control 11****Register 59 (0x3B): Port 3 Control 11 (continued)**

Bit	Name	R/W	Description	Default
3	High priority receive rate flow control enable	R/W	= 1, flow control may be asserted if the port's high priority receive rate is exceeded. (To use this, differential receive rate control must be on.) = 0, flow control is not asserted if the port's high priority receive rate is exceeded.	0
2	Transmit differential priority rate control	R/W	= 1, will do transmit rate control on both high and low priority packets based on the rate counters defined by the high and low priority packets respectively. = 0, will do transmit rate control on any packets. The rate counters defined in low priority will be used.	0
1	Low priority transmit rate control enable	R/W	1, enable the port's low priority transmit rate control feature = 0, disable the port's low priority transmit rate control feature	0
0	High priority transmit rate control enable	R/W	= 1, enable the port's high priority transmit rate control feature = 0, disable the port's high priority transmit rate control feature	0

Note: Port Control 12 and 13, and Port Status 0 contents can also be accessed with the MIIM (MDC/MDIO) interface via the Standard MIIM registers.

Register 28 (0x1C): Port 1 Control 12**Register 44 (0x2C): Port 2 Control 12****Register 60 (0x3C): Reserved, not applied to port 3**

Bit	Name	R/W	Description	Default
7	Auto negotiation enable	R/W	= 0, disable auto negotiation, speed and duplex are decided by bit 6 and 5 of the same register. = 1, auto negotiation is on	For port 1, P1ANEN pin value during reset. For port 2, P2ANEN pin value during reset
6	Force speed	R/W	= 1, forced 100BT if AN is disabled (bit 7) = 0, forced 10BT if AN is disabled (bit 7)	For port 1, P1SPD pin value during reset. For port 2, P2SPD pin value during reset.

Register 28 (0x1C): Port 1 Control 12**Register 44 (0x2C): Port 2 Control 12****Register 60 (0x3C): Reserved, not applied to port 3 (continued)**

Bit	Name	R/W	Description	Default
5	Force duplex	R/W	= 1, forced full duplex if (1) AN is disabled or (2) AN is enabled but failed. = 0, forced half duplex if (1) AN is disabled or (2) AN is enabled but failed.	For port 1, P1DPX pin value during reset. For port 2, P2DPX pin value during reset.
4	Advertised flow control capability	R/W	= 1, advertise flow control (pause) capability = 0, suppress flow control (pause) capability from transmission to link partner	ADVFC pin value during reset.
3	Advertised 100BT full-duplex capability	R/W	= 1, advertise 100BT full-duplex capability = 0, suppress 100BT full-duplex capability from transmission to link partner	1
2	Advertised 100BT half-duplex capability	R/W	= 1, advertise 100BT half-duplex capability = 0, suppress 100BT half-duplex capability from transmission to link partner	1
1	Advertised 10BT full-duplex capability	R/W	= 1, advertise 10BT full-duplex capability = 0, suppress 10BT full-duplex capability from transmission to link partner	1
0	Advertised 10BT half-duplex capability	R/W	= 1, advertise 10BT half-duplex capability = 0, suppress 10BT half-duplex capability from transmission to link partner	1

Register 29 (0x1D): Port 1 Control 13**Register 45 (0x2D): Port 2 Control 13****Register 61 (0x3D): Reserved, not applied to port 3**

Bit	Name	R/W	Description	Default
7	LED off	R/W	= 1, Turn off all port's LEDs (LEDx_3, LEDx_2, LEDx_1, LEDx_0, where "x" is the port number). These pins will be driven high if this bit is set to one. = 0, normal operation	0
6	Txids	R/W	= 1, disable port's transmitter = 0, normal operation	0
5	Restart AN	R/W	= 1, restart auto-negotiation = 0, normal operation	0

Register 29 (0x1D): Port 1 Control 13**Register 45 (0x2D): Port 2 Control 13****Register 61 (0x3D): Reserved, not applied to port 3 (continued)**

Bit	Name	R/W	Description	Default
4	Disable far end fault	R/W	= 1, disable far end fault detection and pattern transmission. = 0, enable far end fault detection and pattern transmission	0 Note: Only port 1 supports fiber. This bit is applicable to port 1 only.
3	Power-down	R/W	= 1, power-down = 0, normal operation	0
2	Disable auto MDI/MDI-X	R/W	= 1, disable auto MDI/MDI-X function = 0, enable auto MDI/MDI-X function	0 For port 2, P2MDIX disable pin value during reset.
1	Force MDI-X	R/W	If auto MDI/MDI-X is disabled, = 1, force PHY into MDI mode (transmit on RXP/RXM pins) = 0, force PHY into MDI-X mode (transmit on TXP/TXM pins)	0 For port 2, P2MDIX pin value during reset.
0	Loopback	R/W	= 1, perform loopback, as indicated: Port 1 Loopback (reg. 29, bit 0 = '1') Start: RXP2/RXM2 (port 2) Loopback: PMD/PMA of port 1's PHY End: TXP2/TXM2 (port 2) Port 2 Loopback (reg. 45, bit 0 '1') Start: RXP1/RXM1 (port 1) Loopback: PMD/PMA of port 2's PHY End: TXP1/TXM1 (port 1) = 0, normal operation	0

Register 30 (0x1E): Port 1 Status 0**Register 46 (0x2E): Port 2 Status 0****Register 62 (0x3E): Reserved, not applied to port 3**

Bit	Name	R/W	Description	Default
7	MDI-X status	RO	= 1, MDI-X = 0, MDI	0
6	AN done	RO	= 1, AN done = 0, AN not done	0
5	Link good	RO	= 1, link good = 0, link not good	
4	Partner flow control capability	RO	= 1, link partner flow control (pause) capable = 0, link partner not flow control (pause) capable	

Register 30 (0x1E): Port 1 Status 0**Register 46 (0x2E): Port 2 Status 0****Register 62 (0x3E): Reserved, not applied to port 3 (continued)**

Bit	Name	R/W	Description	Default
3	Partner 100BT full-duplex capability	RO	= 1, link partner 100BT full-duplex capable = 0, link partner not 100BT full-duplex capable	0
2	Partner 100BT half-duplex capability	RO	= 1, link partner 100BT half-duplex capable = 0, link partner not 100BT half-duplex capable	0
1	Partner 10BT full-duplex capability	RO	= 1, link partner 10BT full-duplex capable = 0, link partner not 10BT full-duplex capable	0
0	Partner 10BT half-duplex capability	RO	= 1, link partner 10BT half-duplex capable = 0, link partner not 10BT half-duplex capable	0

Register 31 (0x1F): Port 1 Status 1**Register 47 (0x2F): Port 2 Status 1****Register 63 (0x3F): Port 3 Status 1**

Bit	Name	R/W	Description	Default
7	Reserved	RO		0
6-5	Reserved	RO		00
4	Receive flow control enable	RO	1 = receive flow control feature is active 0 = receive flow control feature is inactive	0
3	Transmit flow control enable	RO	1 = transmit flow control feature is active 0 = transmit flow control feature is inactive	0
2	Operation speed	RO	1 = link speed is 100Mbps 0 = link speed is 10Mbps	0
1	Operation duplex	RO	1 = link duplex is full 0 = link duplex is half	0
0	Far end fault	RO	= 1, far end fault status detected = 0, no far end fault status detected	0 Note: only port 1 supports fiber; this bit is applicable to port 1 only.

Advanced Control Registers

The IPv4 TOS priority control registers implement a fully decoded 64 bit differentiated services code point (DSCP) register used to determine priority from the 6 bit TOS field in the IP header. The most significant 6 bits of the TOS field are fully decoded into 64 possibilities, and the singular code that results is compared against the corresponding bit in the DSCP register. If the register bit is a 1, the priority is high; if it is a 0, the priority is low.

Register 96 (0x60): TOS Priority Control Register 0

Bit	Name	R/W	Description	Default
7-0	DSCP[63:56]	R/W		0000_0000

Register 97 (0x61): TOS Priority Control Register 1

Bit	Name	R/W	Description	Default
7-0	DSCP[55:48]	R/W		0000_0000

Register 98 (0x62): TOS Priority Control Register 2

Bit	Name	R/W	Description	Default
7-0	DSCP[47:40]	R/W		0000_0000

Register 99 (0x63): TOS Priority Control Register 3

Bit	Name	R/W	Description	Default
7-0	DSCP[39:32]	R/W		0000_0000

Register 100 (0x64): TOS Priority Control Register 4

Bit	Name	R/W	Description	Default
7-0	DSCP[31:24]	R/W		0000_0000

Register 101 (0x65): TOS Priority Control Register 5

Bit	Name	R/W	Description	Default
7-0	DSCP[23:16]	R/W		0000_0000

Register 102 (0x66): TOS Priority Control Register 6

Bit	Name	R/W	Description	Default
7-0	DSCP[15:8]	R/W		0000_0000

Register 103 (0x67): TOS Priority Control Register 7

Bit	Name	R/W	Description	Default
7-0	DSCP[7:0]	R/W		0000_0000

Registers 104 to 109

Registers 104 to 109 define the switching engine's MAC address. This 48-bit address is used as the SA for MAC pause control frames.

Register 104 (0x68): MAC Address Register 0

Bit	Name	R/W	Description	Default
7-0	MACA[47:40]	R/W		0x00

Register 105 (0x69): MAC Address Register 1

Bit	Name	R/W	Description	Default
7-0	MACA[39:32]	R/W		0x10

Register 106 (0x6A): MAC Address Register 2

Bit	Name	R/W	Description	Default
7-0	MACA[31:24]	R/W		0xA1

Register 107 (0x6B): MAC Address Register 3

Bit	Name	R/W	Description	Default
7-0	MACA[23:16]	R/W		0xFF

Register 108 (0x6C): MAC Address Register 4

Bit	Name	R/W	Description	Default
7-0	MACA[15:8]	R/W		0xFF

Register 109 (0x6D): MAC Address Register 5

Bit	Name	R/W	Description	Default
7-0	MACA[7:0]	R/W		0xFF

Register 110 and 111

Use registers 110 and 111 to read or write data to the static MAC address table, VLAN table, dynamic address table, or the MIB counters.

Register 110 (0x6E): Indirect Access Control 0

Bit	Name	R/W	Description	Default
7-5	Reserved	R/W	Reserved	000
4	Read high Write low	R/W	= 1, read cycle = 0, write cycle	0
3-2	Table select	R/W	00 = static MAC address table selected 01 = VLAN table selected 10 = dynamic address table selected 11 = MIB counter selected	00
1-0	Indirect address high	R/W	Bit 9-8 of indirect address	00

Register 111 (0x6F): Indirect Access Control 1

Bit	Name	R/W	Description	Default
7-0	Indirect address low	R/W	Bit 7-0 of indirect address	0000_0000

Note: Write to register 111 will actually trigger a command. Read or write access is determined by Register 110 bit 4.

Register 112 (0x70): Indirect Data Register 8

Bit	Name	R/W	Description	Default
68-64	Indirect data	R/W	Bit 68-64 of indirect data	0_0000

Register 113 (0x71): Indirect Data Register 7

Bit	Name	R/W	Description	Default
63-56	Indirect data	R/W	Bit 63-56 of indirect data	0000_0000

Register 114 (0x72): Indirect Data Register 6

Bit	Name	R/W	Description	Default
55-48	Indirect data	R/W	Bit 55-48 of indirect data	0000_0000

Register 115 (0x73): Indirect Data Register 5

Bit	Name	R/W	Description	Default
47-40	Indirect data	R/W	Bit 47-40 of indirect data	0000_0000

Register 116 (0x74): Indirect Data Register 4

Bit	Name	R/W	Description	Default
39-32	Indirect data	R/W	Bit 39-32 of indirect data	0000_0000

Register 117 (0x75): Indirect Data Register 3

Bit	Name	R/W	Description	Default
31-24	Indirect data	R/W	Bit of 31-24 of indirect data	0000_0000

Register 118 (0x76): Indirect Data Register 2

Bit	Name	R/W	Description	Default
23-16	Indirect data	R/W	Bit 23-16 of indirect data	0000_0000

Register 119 (0x77): Indirect Data Register 1

Bit	Name	R/W	Description	Default
15-8	Indirect data	R/W	Bit 15-8 of indirect data	0000_0000

Register 120 (0x78): Indirect Data Register 0

Bit	Name	R/W	Description	Default
7-0	Indirect data	R/W	Bit 7-0 of indirect data	0000_0000

Registers 121 to 127

Registers 121 to 127 are Reserved.

Static MAC Address Table

The KS8993M has both a static and a dynamic MAC address table. When a destination address (DA) lookup is requested, both tables are searched to make a packet forwarding decision. When a SA lookup is requested, only the dynamic table is searched for aging, migration and learning purposes. The static DA lookup result will have precedence over the dynamic DA lookup result. If there is a DA match in both tables, the result from the static table will be used. The static table can be accessed and controlled by an external processor via the SMI, SPI and I²C interfaces. The external processor performs all addition, modification and deletion of static table entries. These entries in the static table will not be aged out by the KS8993M.

Bit	Name	R/W	Description	Default
57-54	FID	R/W	Filter VLAN ID, representing one of the 16 active VLANs	0000
53	Use FID	R/W	= 1, use (FID+MAC) to look up in static table = 0, use MAC only to look up in static table	0
52	Override	R/W	= 1, override port setting "transmit enable=0" or "receive enable=0" setting = 0, no override	0
51	Valid	R/W	= 1, this entry is valid, the lookup result will be used = 0, this entry is not valid	0

Table 12. Format of Static MAC Table (8 Entries)

Bit	Name	R/W	Description	Default
50-48	Forwarding ports	R/W	These 3 bits control the forwarding port(s): 001, forward to port 1 010, forward to port 2 100, forward to port 3 011, forward to port 1 and port 2 110, forward to port 2 and port 3 101, forward to port 1 and port 3 111, broadcasting (excluding the ingress port)	000
47-0	MAC address	R/W	48 bits MAC address	0x0000_0000_0000

Table 12. Format of Static MAC Table (8 Entries) (continued)

Examples:

1. Static Address Table Read (Read the 2nd Entry)

Write to reg. 110 with 0x10 (read static table selected)
Write to reg. 111 with 0x01 (trigger the read operation)

Then,

Read reg. 113 (57-56)
Read reg. 114 (55-48)
Read reg. 115 (47-40)
Read reg. 116 (39-32)
Read reg. 117 (31-24)
Read reg. 118 (23-16)
Read reg. 119 (15-8)
Read reg. 120 (7-0)

2. Static Address Table Write (Write the 8th Entry)

Write reg. 113 (57-56)
Write reg. 114 (55-48)
Write reg. 115 (47-40)
Write reg. 116 (39-32)
Write reg. 117 (31-24)
Write reg. 118 (23-16)
Write reg. 119 (15-8)
Write reg. 120 (7-0)
Write to reg. 110 with 0x00 (write static table selected)
Write to reg. 111 with 0x07 (trigger the write operation)

VLAN Table

VLAN table is used to do VLAN table lookup. If 802.1Q VLAN mode is enabled (Register 5, Bit 7 = 1), this table will be used to retrieve the VLAN information that is associated with the ingress packet. This information includes FID (filter ID), VID (VLAN ID), and VLAN membership as described in the following table.

Bit	Name	R/W	Description	Default
19	Valid	R/W	= 1, the entry is valid = 0, entry is invalid	1
18-16	Membership	R/W	Specify which ports are members of the VLAN. If a DA lookup fails (no match in both static and dynamic tables), then the packet associated with this VLAN will be forwarded to ports specified in this field. For example, 101 means port 3 and 1 are in this VLAN.	111
15-12	FID	R/W	Filter ID. KS8993M supports 16 active VLANs represented by these four bit fields. FID is the mapped ID. If 802.1Q VLAN is enabled, the lookup will be based on FID+DA and FID+SA.	0x0
11-0	VID	R/W	IEEE 802.1Q 12 bits VLAN ID	0x001

Table 13. Format of Static VLAN Table (16 Entries)

If 802.1Q VLAN mode is enabled, KS8993M will assign a VID to every ingress packet. If the packet is untagged or tagged with a null VID, the packet is assigned with the default port VID of the ingress port. If the packet is tagged with non null VID, the VID in the tag will be used. The lookup process will start from the VLAN table lookup. If the VID is not valid, the packet will be dropped and no address learning will take place. If the VID is valid, the FID is retrieved. The FID+DA and FID+SA lookups are performed. The FID+DA lookup determines the forwarding ports. If FID+DA fails, the packet will be broadcast to all the members (excluding the ingress port) of the VLAN. If FID+SA fails, the FID+SA will be learned.

Examples:

1. VLAN Table Read (read the 3rd entry)

Write to reg. 110 with 0x14 (read VLAN table selected)

Write to reg. 111 with 0x02 (trigger the read operation)

Then

Read reg. 118 (VLAN table bits 19-16)

Read reg. 119 (VLAN table bits 15-8)

Read reg. 120 (VLAN table bits 7-0)

2. VLAN Table Write (write the 7th entry)

Write to reg. 118 (VLAN table bits 19-16)

Write to reg. 119 (VLAN table bits 15-8)

Write to reg. 120 (VLAN table bits 7-0)

Write to reg. 110 with 0x04 (write VLAN table selected)

Write to reg. 111 with 0x06 (trigger the write operation)

Dynamic MAC Address Table

This table is read only. The table contents are maintained by KS8993M only.

Bit	Name	R/W	Description	Default
71	Data not ready	RO	= 1, entry is not ready, retry until this bit is set to 0 = 0, entry is ready	
70-67	Reserved	RO	Reserved	

Table 14. Format of Dynamic MAC Address Table (1K Entries)

Bit	Name	R/W	Description	Default
66	MAC empty	RO	= 1, there is no valid entry in the table = 0, there are valid entries in the table	1
65-56	No of valid entries	RO	Indicates how many valid entries in the table 0x3ff means 1 K entries 0x001 means 2 entries 0x000 and bit 66 = 0 means 1 entry 0x000 and bit 66 = 1 means 0 entry	00_0000_0000
55-54	Time stamp	RO	2 bits counter for internal aging	
53-52	Source port	RO	The source port where FID+MAC is learned 00, port 1 01, port 2 10, port 3	00
51-48	FID	RO	Filter ID	0x0
47-0	MAC address	RO	48 bits MAC address	0x0000_0000_0000

Table 14. Format of Dynamic MAC Address Table (1K Entries) (continued)

Example:

Dynamic MAC Address Table Read (read the 1st entry and retrieve the MAC table size)

Write to reg. 110 with 0x18 (read dynamic table selected)

Write to reg. 111 with 0x00 (trigger the read operation)

Then

Read reg. 112 (71-64) // if bit 71 = 1, restart (reread) from this register

Read reg. 113 (63-56)

Read reg. 114 (55-48)

Read reg. 115 (47-40)

Read reg. 116 (39-32)

Read reg. 117 (31-24)

Read reg. 118 (23-16)

Read reg. 119 (15-8)

Read reg. 120 (7-0)

MIB (Management Information Base) Counters

The KS8993M provides 34 MIB counters per port. These counters are used to monitor the port activity for network management. The MIB counters have two format groups: "Per Port" and "All Port Dropped Packet."

Bit	Name	R/W	Description	Default
31	Reserve	RO	Reserve	0
30	Count valid	RO	= 1, counter value is valid = 0, counter value is not valid	0
29-0	Counter values	RO	Counter value	0

Table 15. Format of "Per Port" MIB Counters

"Per Port" MIB counters are read using indirect memory access. The base address offsets and address ranges for all three ports are:

Port 1, base is 0x00 and range is (0x00-0x1f)

Port 2, base is 0x20 and range is (0x20-0x3f)

Port 3, base is 0x40 and range is (0x40-0x5f)

Port 1's "Per Port" MIB Counters Indirect Memory Offsets are shown in the following table.

Offset	Counter Name	Description
0x0	RxLoPriorityByte	Rx lo-priority (default) octet count including bad packets
0x1	RxHiPriorityByte	Rx hi-priority octet count including bad packets
0x2	RxUndersizePkt	Rx undersize packets w/ good CRC
0x3	RxFragments	Rx fragment packets w/ bad CRC, symbol errors or alignment errors
0x4	RxOversize	Rx oversize packets w/ good CRC (max: 1536 or 1522 bytes)
0x5	RxJabbers	Rx packets longer than 1522 bytes w/ either CRC errors, alignment errors, or symbol errors (depends on max packet size setting)
0x6	RxSymbolError	Rx packets w/ invalid data symbol and legal packet size.
0x7	RxCRCError	Rx packets within (64,1522) bytes w/ an integral number of bytes and a bad CRC (upper limit depends on max packet size setting)
0x8	RxAlignmentError	Rx packets within (64,1522) bytes w/ a non-integral number of bytes and a bad CRC (upper limit depends on max packet size setting)
0x9	RxControl8808Pkts	Number of MAC control frames received by a port with 88-08h in EtherType field
0xA	RxPausePkts	Number of PAUSE frames received by a port. PAUSE frame is qualified with EtherType (88-08h), DA, control opcode (00-01), data length (64B min), and a valid CRC
0xB	RxBroadcast	Rx good broadcast packets (not including error broadcast packets or valid multicast packets)
0xC	RxMulticast	Rx good multicast packets (not including MAC control frames, error multicast packets or valid broadcast packets)
0xD	RxUnicast	Rx good unicast packets
0xE	Rx64Octets	Total Rx packets (bad packets included) that were 64 octets in length
0xF	Rx65to127Octets	Total Rx packets (bad packets included) that are between 65 and 127 octets in length
0x10	Rx128to255Octets	Total Rx packets (bad packets included) that are between 128 and 255 octets in length
0x11	Rx256to511Octets	Total Rx packets (bad packets included) that are between 256 and 511 octets in length
0x12	Rx512to1023Octets	Total Rx packets (bad packets included) that are between 512 and 1023 octets in length
0x13	Rx1024to1522Octets	Total Rx packets (bad packets included) that are between 1024 and 1522 octets in length (upper limit depends on max packet size setting)
0x14	TxLoPriorityByte	Tx lo-priority good octet count, including PAUSE packets
0x15	TxHiPriorityByte	Tx hi-priority good octet count, including PAUSE packets
0x16	TxLateCollision	The number of times a collision is detected later than 512 bit-times into the Tx of a packet
0x17	TxPausePkts	Number of PAUSE frames transmitted by a port
0x18	TxBroadcastPkts	Tx good broadcast packets (not including error broadcast or valid multicast packets)
0x19	TxMulticastPkts	Tx good multicast packets (not including error multicast packets or valid broadcast packets)
0x1A	TxUnicastPkts	Tx good unicast packets

Table 16. Port 1s "Per Port" MIB Counters Indirect Memory Offsets

Offset	Counter Name	Description
0x1B	TxDeferred	Tx packets by a port for which the 1st Tx attempt is delayed due to the busy medium
0x1C	TxTotalCollision	Tx total collision, half duplex only
0x1D	TxExcessiveCollision	A count of frames for which Tx fails due to excessive collisions
0x1E	TxSingleCollision	Successfully Tx frames on a port for which Tx is inhibited by exactly one collision
0x1F	TxMultipleCollision	Successfully Tx frames on a port for which Tx is inhibited by more than one collision

Table 17. Port 1’s “Per Port” MIB Counters Indirect Memory Offsets

Bit	Name	R/W	Description	Default
30-16	Reserved	N/A	Reserved	N/A
15-0	Counter values	RO	Counter value	0

Table 18. Format of “All Port Dropped Packet” MIB Counters

“All Port Dropped Packet” MIB counters are read using indirect memory access. The address offsets for these counters are shown in the following table:

Offset	Counter Name	Description
0x100	Port1 TX Drop Packets	TX packets dropped due to lack of resources
0x101	Port2 TX Drop Packets	TX packets dropped due to lack of resources
0x102	Port3 TX Drop Packets	TX packets dropped due to lack of resources
0x103	Port1 RX Drop Packets	RX packets dropped due to lack of resources
0x104	Port2 RX Drop Packets	RX packets dropped due to lack of resources
0x105	Port3 RX Drop Packets	RX packets dropped due to lack of resources

Table 19. “All Port Dropped Packet” MIB Counters Indirect Memory Offsets

Examples:

1. MIB Counter Read (Read port 1 “Rx64Octets” Counter)

Write to reg. 110 with 0x1c (read MIB counters selected)
 Write to reg. 111 with 0x0e (trigger the read operation)

Then

Read reg. 117 (counter value 30-24) // If bit 30 = 0, restart (reread) from this register
 Read reg. 118 (counter value 23-16)
 Read reg. 119 (counter value 15-8)
 Read reg. 120 (counter value 7-0)

2. MIB Counter Read (Read Port 2 “Rx64Octets” Counter)

Write to reg. 110 with 0x1c (read MIB counter selected)
 Write to reg. 111 with 0x2e (trigger the read operation)

Then,

Read reg. 117 (counter value 30-24) // If bit 30 = 0, restart (reread) from this register
Read reg. 118 (counter value 23-16)
Read reg. 119 (counter value 15-8)
Read reg. 120 (counter value 7-0)

3. MIB Counter Read (Read “Port1 TX Drop Packets” Counter)

Write to reg. 110 with 0x1d (read MIB counter selected)
Write to reg. 111 with 0x00 (trigger the read operation)

Then

Read reg. 119 (counter value 15-8)
Read reg. 120 (counter value 7-0)

Additional Information

Both “Per Port” and “All Port Dropped Packet” MIB counters do not indicate overflow. The application must keep track of overflow conditions for these counters.

“All Port Dropped Packet” MIB counters do not indicate if count is valid. The application must keep track of valid conditions for these counters.

To read out all the counters, the best performance over the SPI bus is $(160+3)*8*200 = 260\text{ms}$, where there are 160 registers, 3 overheads, 8 clocks per access, at 5MHz. In the heaviest condition, the counters will overflow in 2 minutes. It is recommended that the software read all the counters at least every 30 seconds.

A high performance SPI master is also recommended to prevent counters overflow.

Per Port MIB counters are designed as “read clear.” That is, these counters will be cleared after they are read.

“All Port Dropped Packet” MIB counters are not cleared after they are read.

Absolute Maximum Ratings⁽¹⁾

Description	Pins	Value
Supply Storage	N/A	-55°C to 150°C
Supply Voltage	V _{DDA} , V _{DDAP} , V _{DDC} V _{DDATX} , V _{DDARX} , V _{DDIO}	-0.5V to 2.4V -0.5V to 4.0V
Input Voltage (all inputs)	All Inputs	-0.5V to 4.0V
Output Voltage (all outputs)	All Outputs	-0.5V to 4.0V
Lead Temperature (soldering, 10 sec)	N/A	
Storage Temperature (T _s)	N/A	-55°C to 150°C

Note:

1. Exceeding the absolute maximum rating may damage the device.

Stresses greater than those listed in the table above may cause permanent damage to the device. Operation of the device at these or any other conditions above those specified in the operating sections of this specification is not implied. Maximum conditions for extended periods may affect reliability. Unused inputs must always be tied to an appropriate logic voltage level.

Operating Ratings⁽¹⁾

Parameter	Symbol	Min	Typ	Max
Supply Voltages	V _{DDA} , V _{DDAP} , V _{DDC} V _{DDATX} , V _{DDARX} , V _{DDIO}	1.710V 3.135V	1.8V 3.3V	1.890V 3.465V
Ambient Operating Temperature	T _A	0°C		70°C
Maximum Junction Temperature	T _J			125°C
Thermal Resistance Junction to Ambient ⁽²⁾	θ _{JA}		32°C/W	

Notes:

1. The device is not guaranteed to function outside its operating rating. Unused inputs must always be tied to an appropriate logic voltage level (Ground to V_{DD}).
2. No (HS) heat spreader in this package.

Electrical Characteristics⁽¹⁾

$V_{IN} = XX$; $R_L = XX$; $T_A = 25^\circ\text{C}$, bold values indicate $-40^\circ\text{C} \leq T_A \leq +85^\circ\text{C}$; unless noted.

Parameter	Symbol	Condition	Min	Typ	Max
Supply Current (including TX output driver current, KS8993M device only)					
100BASE-TX Operation (All Ports@100% Utilization)					
100BASE-TX (analog core + PLL + digital core)	I_{ddc}	VDDA, VDDAP, VDDC = 1.8V		0.10A	
100BASE-TX (transceiver + digital I/O)	I_{ddxio}	VDDATX, VDDARX, VDDIO = 3.3V		0.16A	
10BASE-T Operation (All Ports@100% Utilization)					
10BASE-T (analog core + PLL + digital core)	I_{ddc}	VDDA, VDDAP, VDDC = 1.8V		0.07A	
10BASE-T (transceiver + digital I/O)	I_{ddxio}	VDDATX, VDDARX, VDDIO = 3.3V		0.19A	
TTL Inputs					
Input High Voltage	V_{ih}		2.0V		
Input Low Voltage	V_{il}				0.8V
Input Current	I_{in}	$V_{in} = \text{GND} \sim \text{VDDIO}$	-10 μA		10 μA
TTL Outputs					
Output High Voltage	V_{oh}	$I_{oh} = -8 \text{ mA}$	2.4V		
Output Low Voltage	V_{ol}	$I_{ol} = 8 \text{ mA}$			0.4V
Output Tri-State Leakage	$ I_{oz} $				10 μA
100BASE-TX Transmit (measured differentially after 1:1 transformer)					
Peak Differential Output Voltage	V_o	100 Ω termination on the differential output.	0.95V		1.05V
Output Voltage Imbalance	V_{imb}	100 Ω termination on the differential output			2%
Rise/Fall Time	T_r/T_f		3ns		5ns
Rise/Fall Time Imbalance			0ns		0.5ns
100BASE-TX Transmit (measured differentially after 1:1 transformer)					
Duty Cycle Distortion					$\pm 0.5\text{ns}$
Overshoot					5%
Reference Voltage of ISET	V_{set}			0.5V	
Output Jitters		Peak-to-peak		0.7ns	1.4ns

Note:

1. Specification for packaged product only.

Electrical Characteristics (continued)⁽¹⁾

Parameter	Symbol	Condition	Min	Typ	Max
10BaseT Receive					
Squelch Threshold	V_{sq}	5MHz square wave		400mV	
10BaseT Transmit (measured differentially after 1:1 transformer) VDDATX = 3.3V only					
Peak Differential Output Voltage	V_p	100 Ω termination on the differential output.		2.3V	
Jitters Added		100 Ω termination on the differential output.			± 3.5 ns
Rise/Fall Time				25ns	

Note:

1. Specification for packaged product only.

Timing Specifications

EEPROM Timing

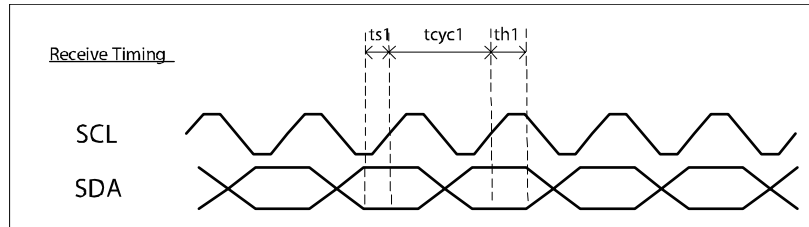

Figure 13. EEPROM Interface Input Timing Diagram

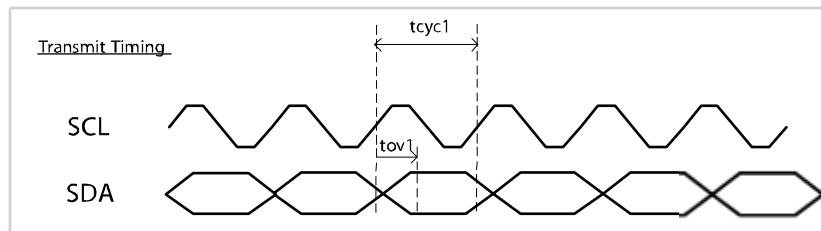

Figure 14. EEPROM Interface Output Timing Diagram

Timing Parameter	Description	Min	Typ	Max	Unit
t_{cyc1}	Clock cycle		16384		ns
t_{s1}	Setup time	20			ns
t_{h1}	Hold time	20			ns
t_{ov1}	Output valid	4096	4112	4128	ns

Table 20. EEPROM Timing Parameters

SNI Timing

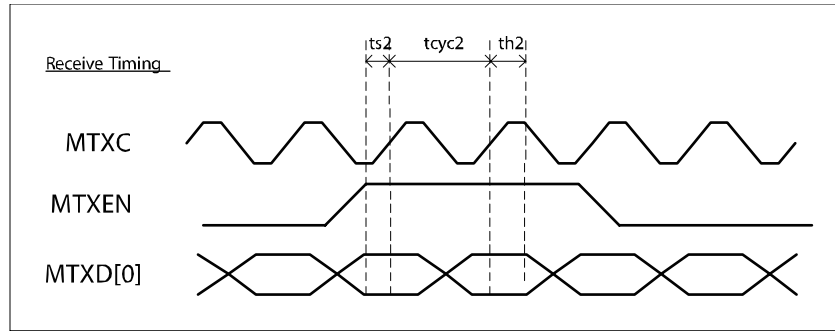

Figure 15. SNI Input Timing Diagram

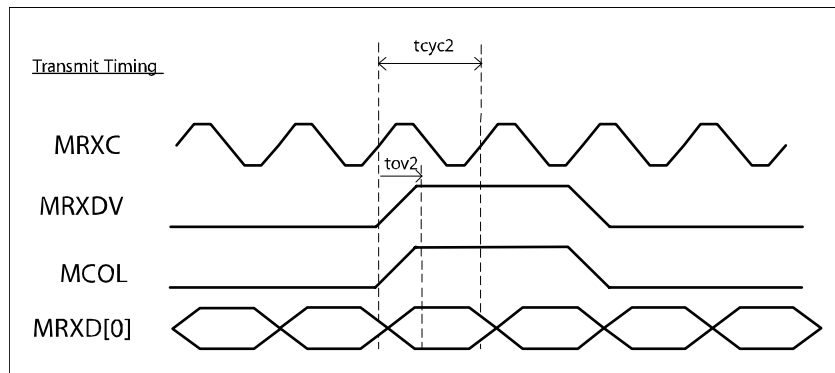

Figure 16. SNI Output Timing Diagram

Timing Parameter	Description	Min	Typ	Max	Unit
t_{cyc2}	Clock cycle		100		ns
t_{s2}	Setup time	10			ns
t_{h2}	Hold time	0			ns
t_{ov2}	Output valid	0	3	6	ns

Table 21. SNI Timing Parameters

MII Timing

MAC Mode MII Timing

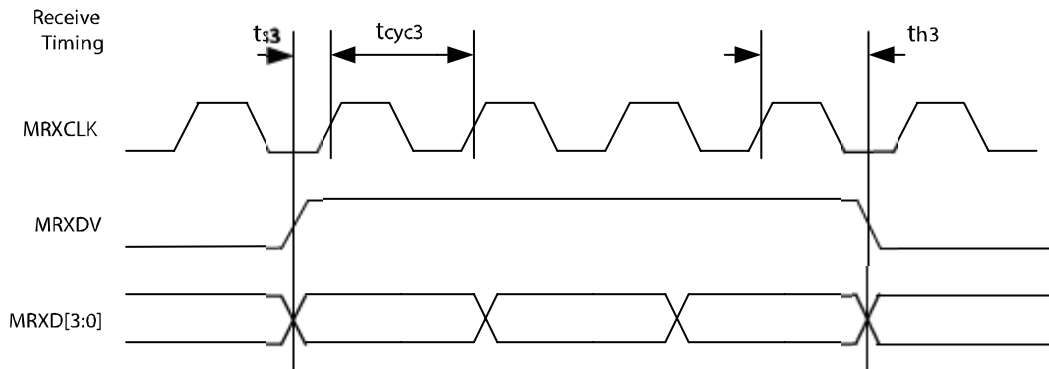

Figure 17. MAC-Mode MII Timing – Data Received from MII

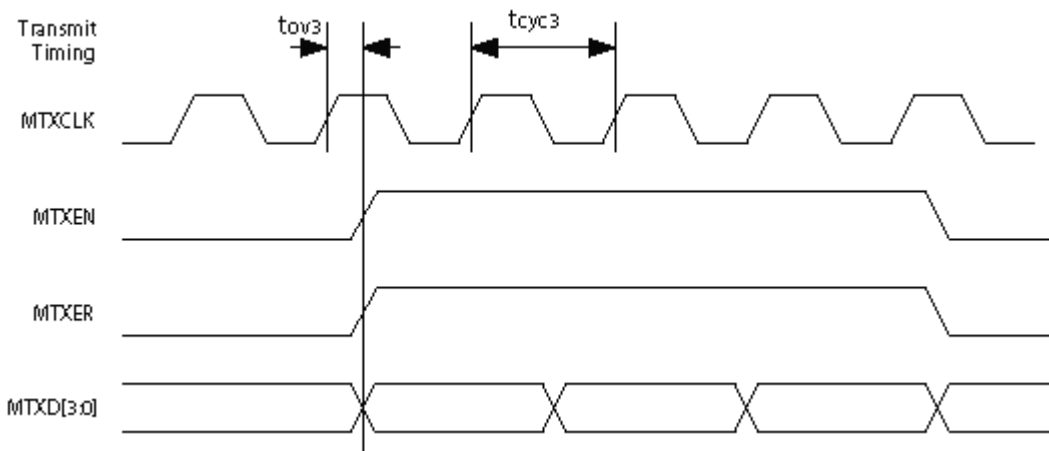

Figure 18. MAC-Mode MII Timing – Data Input to MII

Timing Parameter	Description	Min	Typ	Max	Unit
t_{cyc3} (100BASE-T)	Clock cycle 100BASE-T		40		ns
t_{cyc3} (10BASE-T)	Clock cycle 10BASE-T		400		ns
t_{s3}	Setup time	10			ns
t_{h3}	Hold time	10			ns
t_{ov3}	Output valid	0		25	ns

Table 22. MAC-Mode MII Timing Parameters

PHY-Mode MII Timing

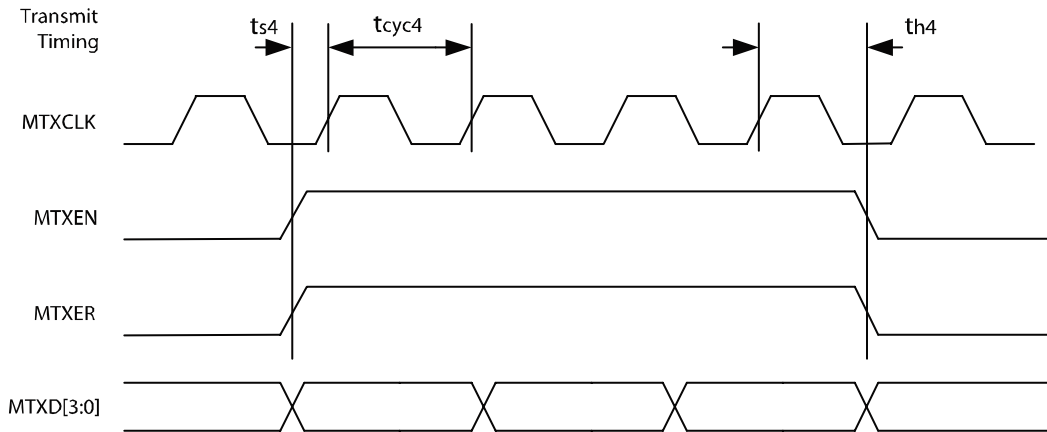

Figure 19. PHY-Mode MII Timing – Data Received from MII

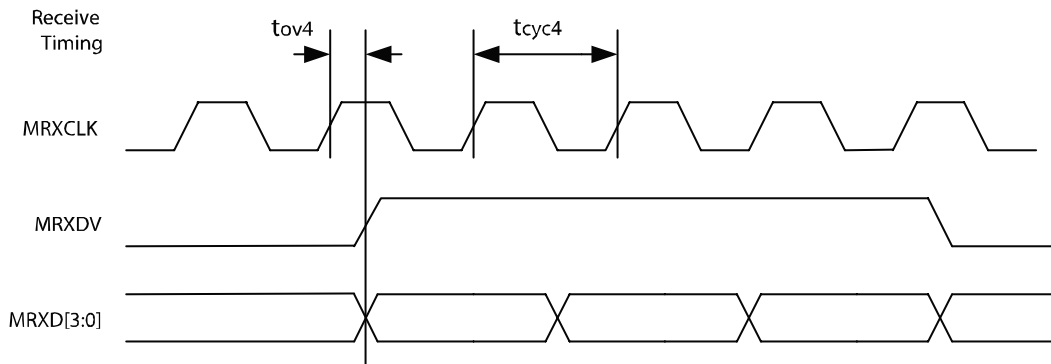

Figure 20. PHY-Mode MII Timing – Data Input to MII

Timing Parameter	Description	Min	Typ	Max	Unit
tcyc4 (100BASE-T)	Clock cycle 100BASE-T		40		ns
tcyc4 (10BASE-T)	Clock cycle 10BASE-T		400		ns
ts4	Setup time	10			ns
th4	Hold time	10			ns
tov4	Output valid	0		25	ns

Table 23. PHY-Mode MII Timing Parameters

SPI Timing

Input Timing

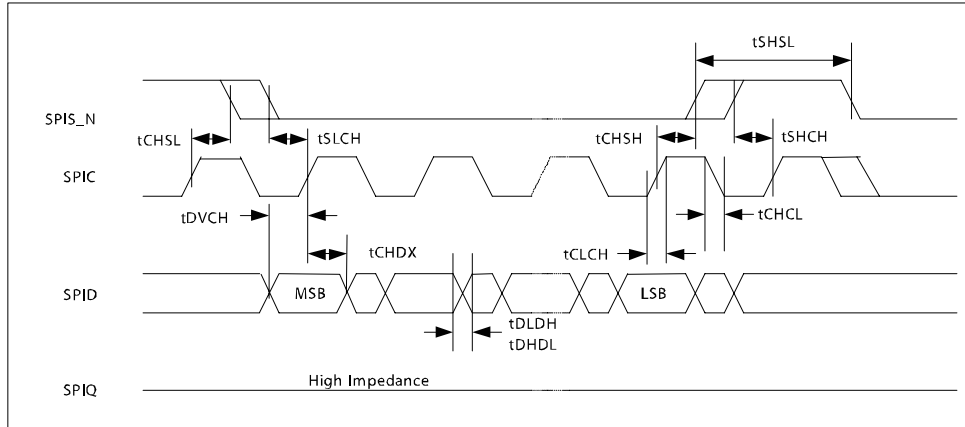

Figure 21. SPI Input Timing

Timing Parameter	Description	Min	Max	Units
fC	Clock frequency		5	MHz
tCHSL	SPIS_N inactive hold time	90		ns
tSLCH	SPIS_N active setup time	90		ns
tCHSH	SPIS_N active old time	90		ns
tSHCH	SPIS_N inactive setup time	90		ns
tSHSL	SPIS_N deselect time	100		ns
tDVCH	Data input setup time	20		ns
tCHDX	Data input hold time	30		ns
tCLCH	Clock rise time		1	us
tCHCL	Clock fall time		1	us
tDLDH	Data input rise time		1	us
tDHDL	Data input fall time		1	us

Table 24. SPI Input Timing Parameters

Output Timing

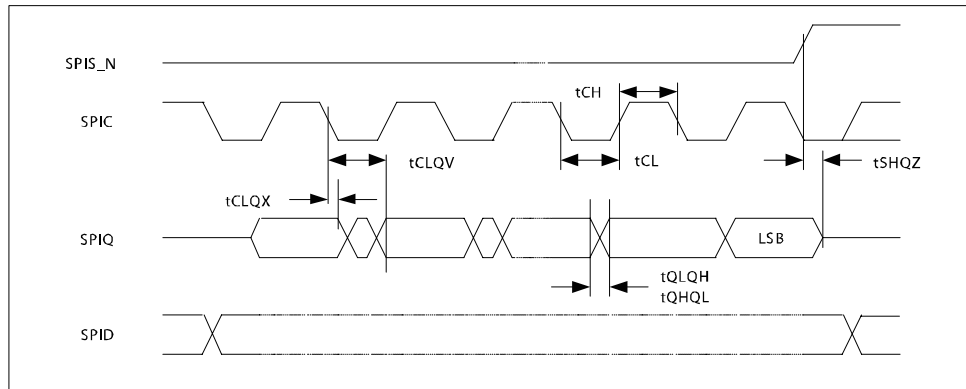

Figure 22. SPI Output Timing

Timing Parameter	Description	Min	Max	Units
fC	Clock frequency		5	MHz
tCLQX	SPIQ hold time	0	0	ns
tCLQV	Clock low to SPIQ valid		60	ns
tCH	Clock high time	90		ns
tCL	Clock low time	90		
tQLQH	SPIQ rise time		50	ns
tQHQL	SPIQ fall time		50	ns
tSHQZ	SPIQ disable time		100	ns

Table 25. SPI Output Timing Parameters

Reset Timing

As long as the stable supply voltages to reset high timing (minimum of 10ms) are met, there is no power sequencing requirement for the KS8993M supply voltages (1.8V, 3.3).

It is recommended to wait 100µsec after the de-assertion of reset before starting programming on the managed interface.

The reset timing requirement is summarized in the following figure and table.

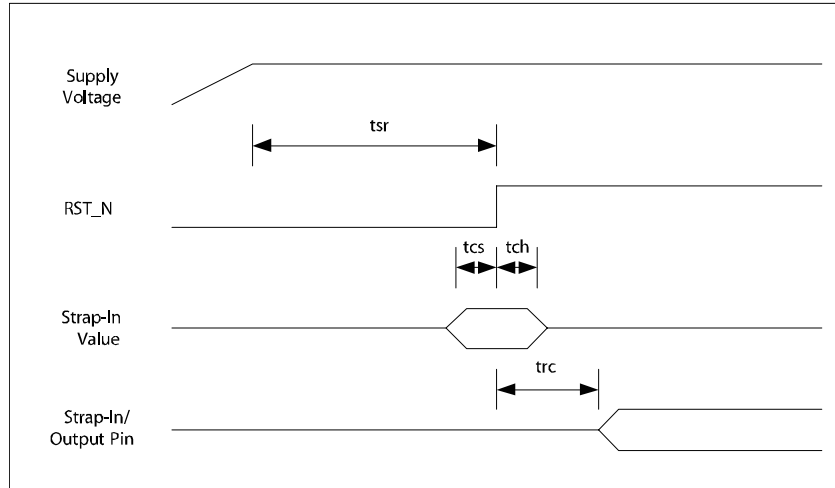

Figure 23. Reset Timing

Parameter	Description	Min	Max	Units
t _{sr}	Stable supply voltages to reset high	10		ms
t _{cs}	Configuration setup time	50		ns
t _{ch}	Configuration hold time	50		ns
t _{rc}	Reset to strap-in pin output	50		us

Table 26. Reset Timing Parameters

Reset Circuit Diagram

Micrel recommends the following discrete reset circuit as shown in Figure 24 when powering up the KS8893M/ML/MI device. For the application where the reset circuit signal comes from another device (e.g., CPU, FPGA, etc), we recommend the reset circuit as shown in Figure 25.

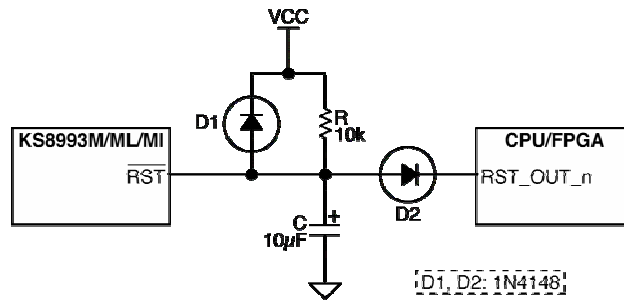

Figure 24. Recommended Reset Circuit

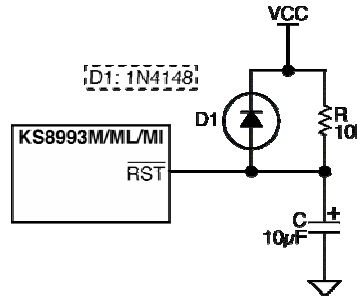

Figure 25. Recommended Circuit for Interfacing with CPU/FPGA Reset

At power-on-reset, R, C, and D1 provide the necessary ramp rise time to reset the Micrel device. The reset out from CPU/FPGA provides warm reset after power up. It is also recommended to power up the VDD core voltage earlier than VDDIO voltage. At worst case, the both VDD core and VDDIO voltages should come up at the same time.

Selection of Isolation Transformers

A 1:1 isolation transformer is required at the line interface. An isolation transformer with integrated common-mode choke is recommended for exceeding FCC requirements.

The following table gives recommended transformer characteristics.

Parameter	Value	Test Condition
Turns ratio	1 CT : 1 CT	
Open-circuit inductance (min.)	350 μ H	100mV, 100kHz, 8mA
Leakage inductance (max.)	0.4 μ H	1MHz (min.)
Inter-winding capacitance (max.)	12pF	
D.C. resistance (max.)	0.9 Ω	
Insertion loss (max.)	1.0dB	0MHz – 65MHz
HIPOT (min.)	1500Vrms	

Table 27. Transformer Selection Criteria

Magnetic Manufacturer	Part Number	Auto MDI-X	Number of Port
Bel Fuse	S558-5999-U7	Yes	1
Bel Fuse	SI-46001	Yes	1
Bel Fuse	SI-50170	Yes	1
Delta	LF8505	Yes	1
LanKom	LF-H41S	Yes	1
Pulse	H1102	Yes	1
Pulse (low cost)	H1260	Yes	1
Transpower	HB726	Yes	1
YCL	LF-H41S	Yes	1

Table 28. Qualified Single Port Magnetics

Selection of Reference Crystal

Characteristics	Value	Units
Frequency	25.00000	MHz
Frequency tolerance (max)	\pm 50	ppm
Load capacitance (max)	20	pF
Series resistance	25	Ω

Table 29. Typical Reference Crystal Characteristics

