

E50S Series

Diameter ϕ 50mm Shaft type Incremental Rotary encoder

Line-up

Features

- 12–24VDC power supply of line driver output(Line-up)
- Suitable for measuring angle, position, revolution, speed, acceleration and distance
- Power supply : 5VDC, 12–24VDC \pm 5%

Applications

- Various tooling machinery, packing machine and general industrial machinery etc.

⚠ Please read "Caution for your safety" in operation manual before using.



Ordering information (Former name : ENB)

E50S	8	—	5000	—	3	—	N	—	24	—	
Series	Shaft diameter	Pulse/1 Revolution	Output phase	Output	Power supply	Cable					
Diameter ϕ 50mm, shaft type	ϕ 8mm	Refer to resolution	2:A, B 3:A, \bar{B} , Z 4:A, \bar{A} , B, \bar{B} 6:A, \bar{A} , B, \bar{B} , Z, \bar{Z}	T:Totem pole output N:NPN open collector output V:Voltage output L:Line driver output	5 :5VDC \pm 5% 24:12–24VDC \pm 5%	Blank:Normal type C:Cable outgoing connector type(*) CR:Rear side outgoing connector integrated type CS:Side outgoing connector integrated type					

*Standard:E50S8-PULSE-3-N-24

*Cable length:250mm

Specifications

Item	Diameter ϕ 50mm shaft type of incremental rotary encoder		
Resolution(P/R)	(Note1) *1, *2, *5, 10, 12, 15, 20, 23, 25, 30, 35, 40, 45, 50, 60, 75, 100, 120, 125, 150, 192, 200, 240, 250, 256, 300, 360, 400, 500, 512, 600, 800, 1000, 1024, 1200, 1500, 1800, 2000, 2048, 2500, 3000, 3600, 5000, 6000, 8000		
Electrical specification	Output phase	A, B, Z phase(Line driver : A, \bar{A} , B, \bar{B} , Z, \bar{Z} phase)	
	Phase difference of output	Phase difference between A and B : $\frac{T}{4} \pm \frac{T}{8}$ (T=1cycle of A phase)	
	Control output	Totem pole output	• Low \Rightarrow Load current:Max. 30mA, Residual voltage : Max. 0.4VDC • High \Rightarrow Load current:Max. 10mA, Output voltage(Power supply 5VDC):Min. (Power supply-2.0)VDC, Output voltage(Power supply 12–24VDC):Min. (Power supply-3.0)VDC
		NPN open collector output	Load current : Max. 30mA, Residual voltage : Max. 0.4VDC
		Voltage output	Load current : Max. 10mA, Residual voltage : Max. 0.4VDC
		Line driver output	• Low \Rightarrow Load current : Max. 20mA, Residual : Max. 0.5VDC • High \Rightarrow Load current : Max. -20mA, Output voltage (Power supply 5VDC) : Min. 2.5VDC, Output voltage (Power supply 12–24VDC) : Min. (Power supply-3.0)VDC
	Response time (Rise/Fall)	Totem pole output	Max. 1 μ s
		NPN open collector output	Max. 1 μ s
		Voltage output	Max. 1 μ s
		Line driver output	Max. 0.5 μ s
	Max. Response frequency	300kHz	
	Power supply	• 5VDC \pm 5% (Ripple P-P : Max. 5%) • 12–24VDC \pm 5% (Ripple P-P : Max. 5%)	
	Current consumption	Max. 80mA (disconnection of the load), Line driver output : Max. 50mA (disconnection of the load)	
Insulation resistance	Min. 100M Ω (at 500VDC megger between all terminals and case)		
Dielectric strength	750VAC 50/60Hz for 1 minute (Between all terminals and case)		
Connection	Cable outgoing type, 200mm cable outgoing connector type, Connector integrated type (Rear, Side)		
Mechanical specification	Starting torque	Max. 70gf \cdot cm (0.007N \cdot m) (Note2) / Max. 800gf \cdot cm (0.08N \cdot m) (Note3)	
	Moment of inertia	Max. 80g \cdot cm ² (8×10^{-6} kg \cdot m ²) (Note2) / Max. 400g \cdot cm ² (4×10^{-5} kg \cdot m ²) (Note3)	
	Shaft loading	Radial : Max. 10kgf, Thrust : Max. 2.5kgf	
	Max. allowable revolution	(Note4) 5000rpm	
Vibration	1.5mm amplitude at frequency of 10 to 55Hz in each of X, Y, Z directions for 2 hours		
Shock	Max. 75G		
Ambient temperature	-10 to 70 $^{\circ}$ C (at non-freezing status), Storage : -25 to 85 $^{\circ}$ C		
Ambient humidity	35 to 85%RH, Storage : 35 to 90%RH		
Protection	Normal type, Cable outgoing connector type: IP50 (IEC standard) (Note5) , Connector integrated type: IP65 (IEC standard)		
Cable	ϕ 5mm, 5P, Length : 2m, Shield cable (Line driver output : ϕ 5mm, 8P) (AWG 24, Core wire diameter : 0.08mm, No. of core wire : 40, Insulator out diameter : ϕ 1mm)		
Accessory	ϕ 8mm coupling, bracket		
Approval	CE (Except for line driver output)		
Unit weight	Approx. 275g, Connector integrated type : 180g		

※ **(Note1)** '*' pulse is only for A, B phase (Line driver output is for A, \bar{A} , B, \bar{B} phase).

※ **(Note2)** This value is for normal type, cable outgoing connector type (Protection: IP50).

※ **(Note3)** This value is for normal type, cable outgoing connector type (Protection: IP64)/connector integrated type (Protection: IP65)

※ **(Note4)** Max. allowable revolution \geq Max. response revolution [Max. response resolution (rpm) = $\frac{\text{Max. response frequency}}{\text{Resolution}} \times 60 \text{ sec.}$]

※ **(Note5)** 'Normal type, cable outgoing connector type is option as IP64 protection.

Incremental ϕ 50mm Shaft Type

Control output diagram

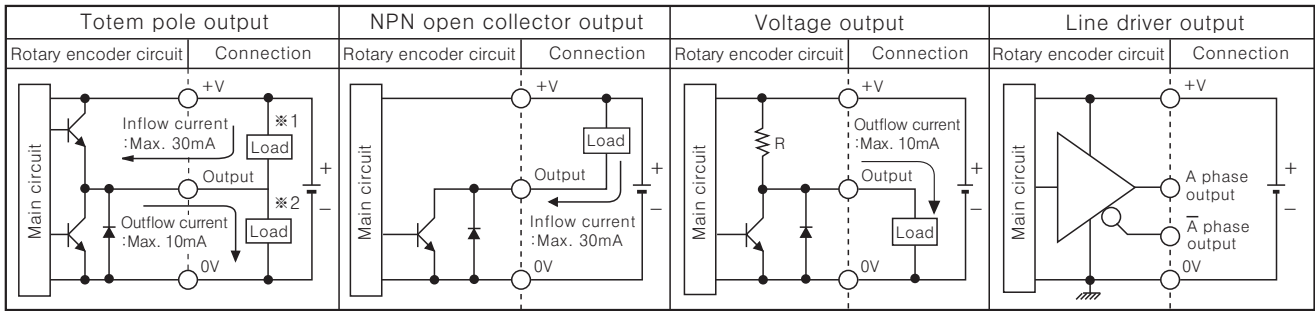

- Totem pole output type can be used for NPN open collector output type(*1) or Voltage output type(*2).
- All output circuits of A, B, Z phase are the same. (Line driver output is A, \bar{A} , B, \bar{B} , Z, \bar{Z})

Output waveform

- Totem pole output / NPN open collector output / Voltage output

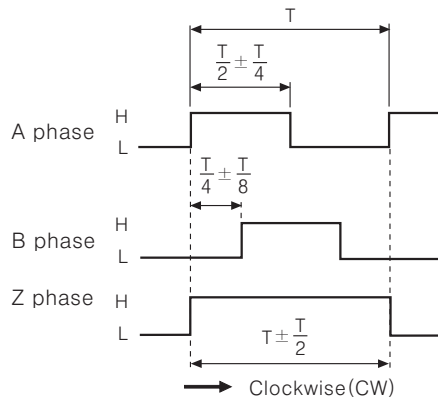

*CW : Right turn as from the shaft

- Line driver output

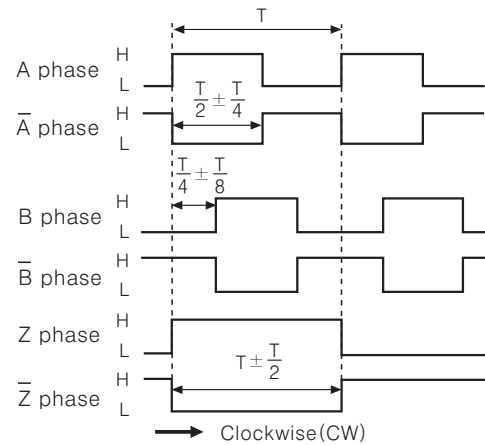

Connections

Normal type

- Totem pole output / NPN open collector output / Voltage output

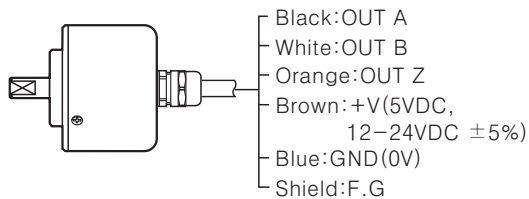

- *Unused wires must be insulated.
- *The metal and shield cable of encoder should be grounded(F,G)

- Line driver output

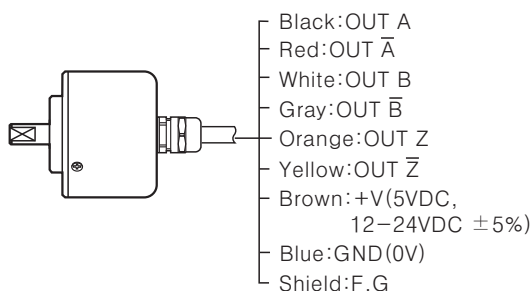

Cable outgoing connector/ Connector integrated type

- Totem pole output
- NPN open collector output
- Voltage output
- Line driver output

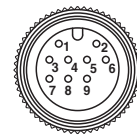

Totem pole output NPN open collector output Voltage output			Line driver output		
Pin No	Function	Cable color	Pin No	Function	Cable color
①	OUT A	Black	①	OUT A	Black
②	OUT B	White	②	OUT \bar{A}	Red
③	OUT Z	Orange	③	+V	Brown
④	+V	Brown	④	GND	Blue
⑤	GND	Blue	⑤	OUT B	White
⑥	F.G	Shield	⑥	OUT \bar{B}	Gray
			⑦	OUT Z	Orange
			⑧	OUT \bar{Z}	Yellow
			⑨	F.G	Shield

*F.G(Field Ground) : It should be grounded separately.

(A) Photo electric sensor

(B) Fiber optic sensor

(C) Door/Area sensor

(D) Proximity sensor

(E) Pressure sensor

(F) Rotary encoder

(G) Connector/Socket

(H) Temp. controller

(I) SSR/Power controller

(J) Counter

(K) Timer

(L) Panel meter

(M) Tacho/Speed/Pulse meter

(N) Display unit

(O) Sensor controller

(P) Switching power supply

(Q) Stepping motor & Driver & Controller

(R) Graphic/Logic panel

(S) Field network device

(T) Production stoppage models & replacement

E50S Series

■ Dimensions

(Unit:mm)

■ Normal type, Cable outgoing connector type(Protection : IP50)

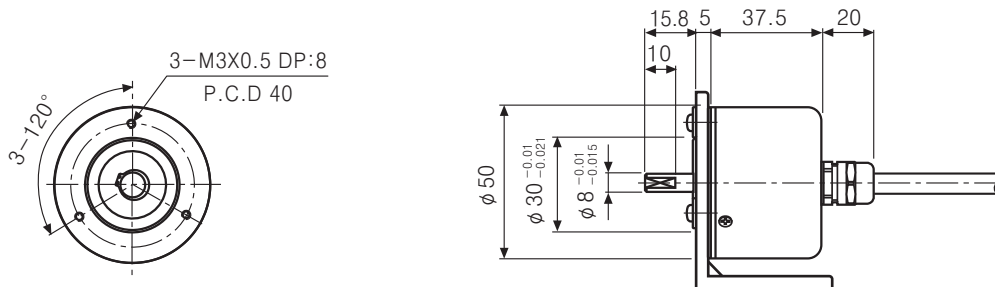

■ Normal type, Cable outgoing connector type(Protection : IP64)

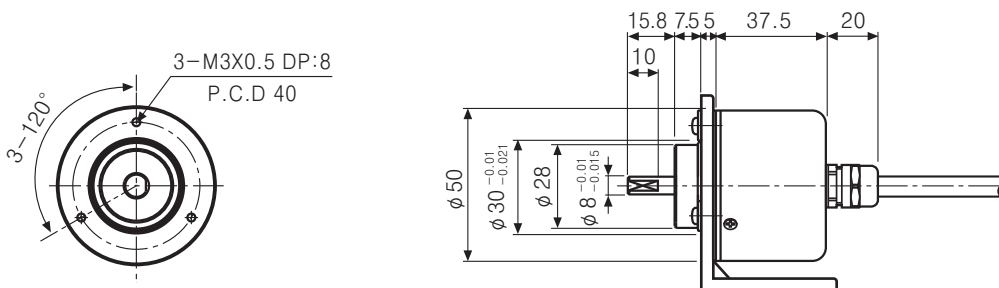

Cable for normal type	Cable for Cable outgoing connector type
φ 5mm, 5P(Line driver output:8P), Length:2000, Shield cable	φ 5mm, 5P(Line driver output:8P), Length:250, Shield cable

※ Connector cable is customizable and see G-6 for specifications.

■ Rear/Side connector integrated type(Protection: IP65)

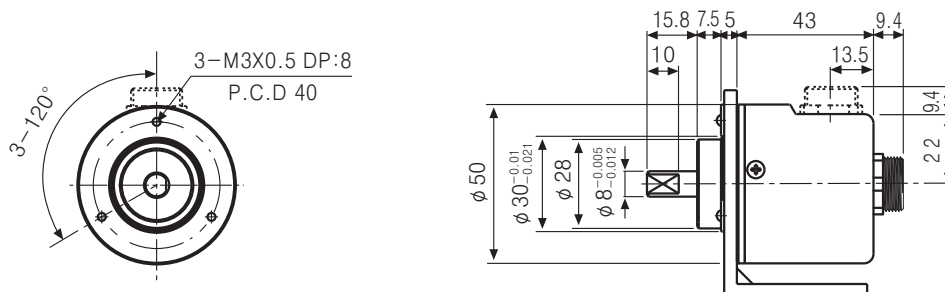

● Bracket

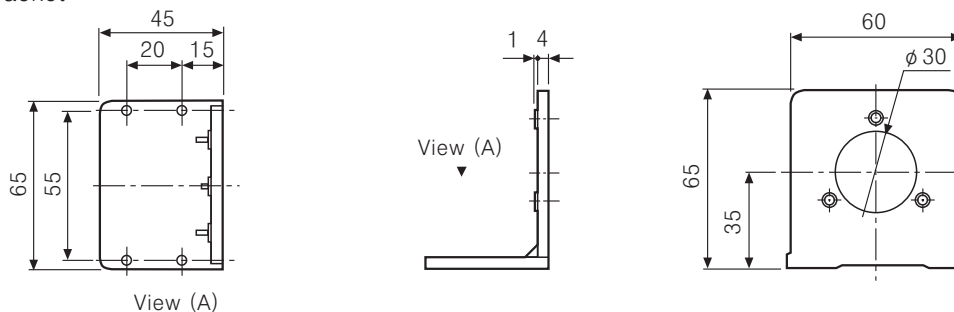

● Coupling(E50S)

