

## Five Channel Programmable DC-DC System Power Manager

### FEATURES & APPLICATIONS

- Digital programming of all major parameters via I<sup>2</sup>C interface and non-volatile memory
  - Output voltage set point
  - Output power-up/down sequencing
  - Input/Battery voltage monitoring
  - Digital soft-start and output slew rate
  - Output voltage margining
  - UV/OV monitoring of all outputs
  - Enable/Disable outputs independently
- Five output channels
  - Two synchronous step-down (buck) channels
  - One step-up (boost) channel
  - One inverting (buck-boost) channel
  - One fixed output +3.3V LDO
- User friendly Graphical User Interface (GUI)
- +2.7V to +6.0V Input Range
- Highly accurate reference and output voltage (<0.5%) with Active DC Output Control (ADOC™) technology
- Undervoltage Lockout (UVLO) with hysteresis
- 800 kHz operating frequency
- 96 bytes of user configurable nonvolatile memory

### Applications

- Digital camcorders/still cameras
- Portable DVD/MP3/GPS
- Camera/smart phones
- TFT Displays/Monitors/TV's
- Mobile Computing/PDA's
- Consumer battery-operated equipment

### INTRODUCTION

The SMB110 is a highly integrated and flexible five-channel power manager designed for use in a wide range of portable applications. The built-in digital programmability allows system designers to custom tailor the device to suit almost any multi-channel power supply application from digital camcorders to mobile phones. Complete with a user friendly GUI, all programmable settings including output voltages and input/output voltage monitoring can be customized with ease.

The SMB110 integrates all the essential blocks required to implement a complete five-channel power subsystem including two synchronous step-down “buck” controllers, one step-up “boost” controller, one inverting “buck-boost” controller and one fixed output +3.3V LDO. Additionally sophisticated power control/monitoring functions required by complex systems are built-in. These include digitally programmable output voltage set point, power-up/down sequencing, enable/disable, margining and UV/OV/input/output monitoring on all channels.

The integration of features and built-in flexibility of the SMB110 allows the system designer to create a “platform solution” that can be easily modified via software without major hardware changes. Combined with the re-programmability of the SMB110 this facilitates rapid design cycles and proliferation from a base design to future generations of product.

The SMB110 is suited to battery-powered applications with an input range of +2.7V to +6.0V. Output voltages are extremely accurate (<0.5%) employing proprietary ADOC™ technology. Communication is via the industry standard I<sup>2</sup>C bus. All user-programmed settings are stored in non-volatile EEPROM of which 96 bytes may be used for general-purpose memory applications. The operating temperature range is +0C to +70C and the available package is a lead-free, Green, RoHS compliant, 32-pad QFN-32.

### SIMPLIFIED APPLICATIONS DRAWING

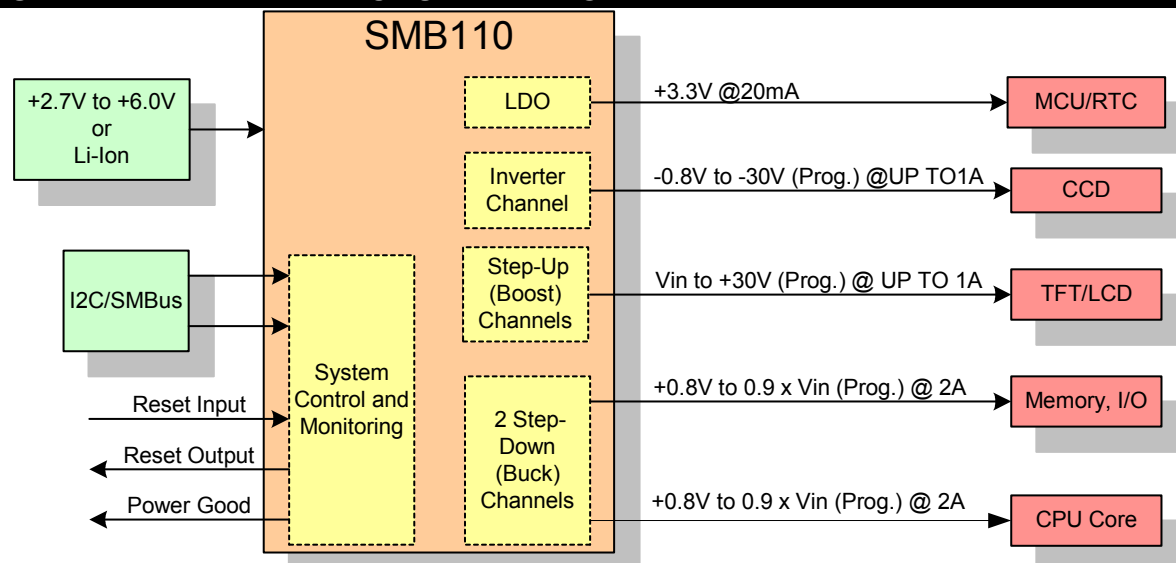

**Figure 1 – Applications diagram featuring the SMB110 five-channel, programmable DC-DC controller**

Note: This is an applications example only. Some pins, components and values are not shown.



## TABLE OF CONTENTS

General Description .....	3	Monitoring .....	21
Typical Application .....	4	Output Voltage .....	21
Internal Block Diagram.....	5	LDO Standby Voltage .....	22
Pin Descriptions .....	6-8	Soft Start .....	22
Package and Pin Configuration .....	9	Power-On Sequencing FlowChart .....	23
Absolute Maximum Ratings .....	10	Minimum Load .....	24
Recommended Operating Conditions.....	10	Margining .....	24
DC Operating Characteristics .....	10-13	Application Schematic.....	25
AC Operating Characteristics .....	14-15	Bill of materials.....	26-27
I <sup>2</sup> C 2-Wire Serial Interface AC Operating Characteristics- 100khz.....	16	<b>Programming information</b>	
Timing Diagrams: I <sup>2</sup> C.....	16	Development Hardware & Software .....	28
Efficiency Graphs.....	17	Serial Interface .....	29
Transient Response.....	18	Write.....	29
Timing Diagrams: Power-On Sequence .....	19	Read.....	29
<b>Applications Information: Device Operation</b>		Configuration Registers .....	29
Power Supply .....	20	General Purpose Memory.....	29
Enable .....	20	GUI.....	30
Power-On Sequencing.....	20	I <sup>2</sup> C memory read and writes .....	31
Normal Sequencing .....	20	Default Configuration Register Setting .....	32
Sequencing With Enable.....	20	Part Marking.....	33
Sequencing with channel bypass .....	21	Package .....	34
Manual Mode .....	21	Ordering Information .....	35
		Legal Notice .....	35



## GENERAL DESCRIPTION

The SMB110 is a fully programmable DC-DC controller that monitors, margins, and cascade sequences. It has 5 voltage outputs, consisting of: two synchronous “buck” step-down controllers, one “boost” step-up controller, one “boost-buck” negative DC-DC controller, and one LDO.

The SMB110 uses a fixed 800 kHz Pulse Width Modulation (PWM) control circuit. A type three voltage mode compensation network is used offering a cost effective solution without compromising the transient response. By utilizing external n and p-type MOSFET transistors the efficiency and load current can be customized to fit a wide array of system requirements.

The SMB110 integrates two buck outputs that are capable of producing an output voltage less than the input voltage. Each buck output voltage is set by an internal resistor divider and a programmable voltage reference. The integrated resistor divider eliminates the cost and space necessary for external components and has several programmable values. Through the programmability of the reference and the resistor divider, practically any output voltage less than the battery can be produced without the need to change external components.

In addition, the SMB110 integrates one boost output capable of producing an output voltage greater than the input voltage. The boost topology is asynchronous, using a rectifying Schottky diode and eliminating the need for an additional external MOSFET driver. An external p-channel sequencing MOSFET's accompanies the boost channel in order to isolate the switching MOSFET from the battery when disabled.

The SMB110 also contains one inverting buck-boost output capable of producing a negative output voltage less than or greater than, the input voltage. The buck boost output is asynchronous and drives an external p-channel MOSFET.

A Low DropOut linear regulator with fixed 3.3 volt output provides a low current supply for “always on” microcontrollers. The LDO has a special input supply that is internally multiplexed between the LDO supply pin and the battery. This ensures that the LDO will always be active over the recommended operating voltages (2.7V – 6.0V).

The SMB110 is capable of power-on/off cascade sequencing where each channel can be assigned one of

four unique sequence positions. During sequencing each channel in a given sequence position is guaranteed to reach its programmed output voltage before the channel(s) occupying the next sequence position initiate their respective soft-start sequence. A unique programmable delay exists between each power on/off sequence position. In addition to power on/off sequencing all supplies can be powered on/off individually through an I<sup>2</sup>C command or by assertion of an enable pin.

Each output voltage is monitored for under-voltage and over-voltage (UV/OV) conditions, using a comparator-based circuit where the output voltage is compared against an internal programmable reference. An additional feature of the output voltage monitoring is a programmable glitch filter capable of digitally filtering a transient OV/UV fault condition from a true system error. When a fault is detected for a period in excess of the glitch filter, all supplies may be sequenced down or immediately disabled and one of two output status pins can be asserted. The current system status is always accessible via internal registers containing the status of all four channels.

The SMB110 possesses an Undervoltage Lockout (UVLO) circuit to ensure the SMB110 will not power up until the battery voltage has reached a safe operating voltage. The UVLO function exhibits hysteresis, ensuring that noise or a brown out voltage on the supply rail does not inadvertently lead to a system failure.

The SMB110 provides margining control over all of its output voltages. Through an I<sup>2</sup>C command, all outputs can be margined to any voltage setting within the nominal output voltage range. Margining creates three pre-programmed settings that each channel can be set to via an I<sup>2</sup>C command. Margining is ideal when used with the boost channel configured as an LED driver where margining provides three brightness settings.

In addition, each output is slew rate limited by soft-start circuitry that is user programmable and requires no external capacitors.

All programmable settings on the SMB110 are stored in non-volatile registers and are easily accessed and modified over an industry standard I<sup>2</sup>C serial bus. For fastest prototype development times Summit offers an evaluation card and a Graphical User Interface (GUI).



## TYPICAL APPLICATION

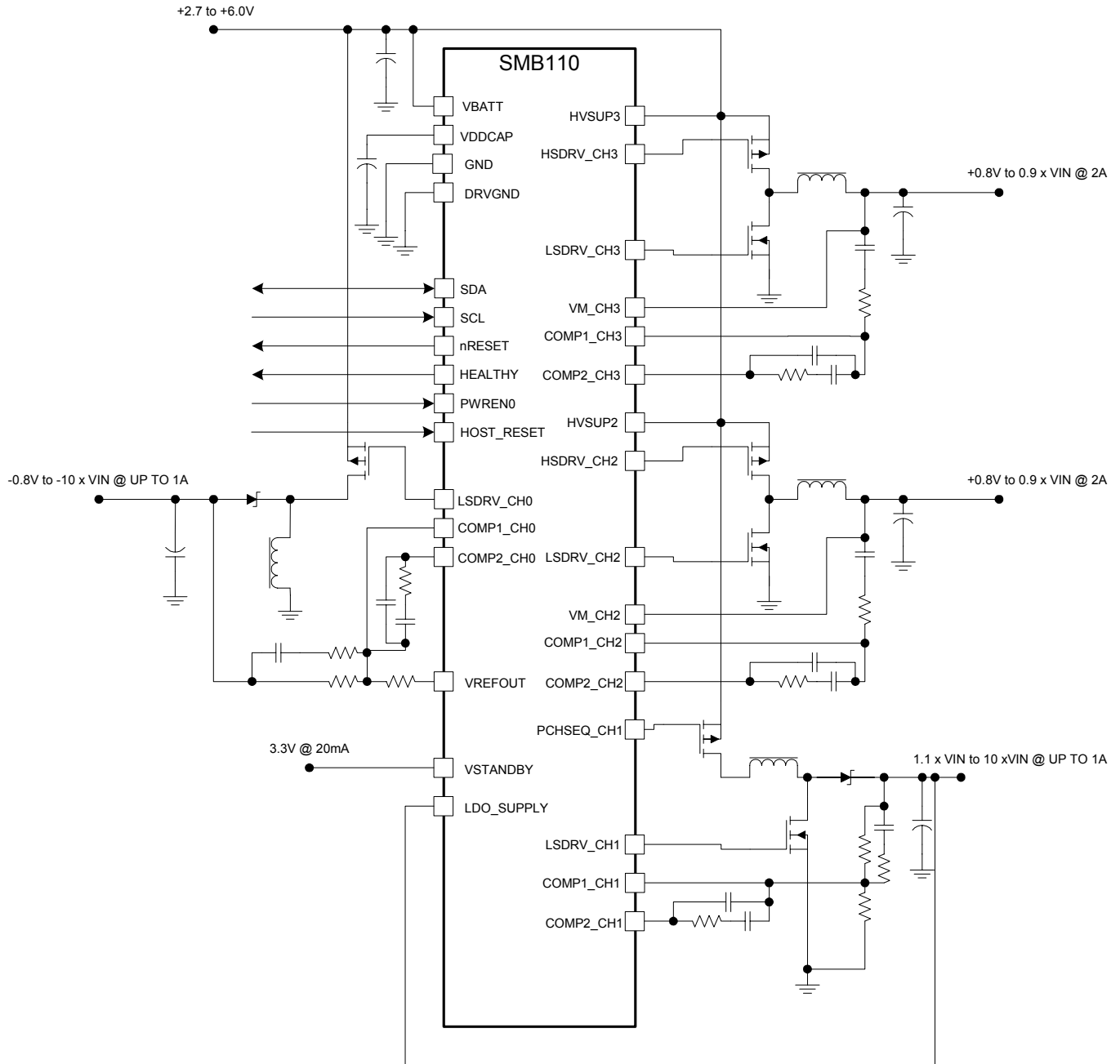
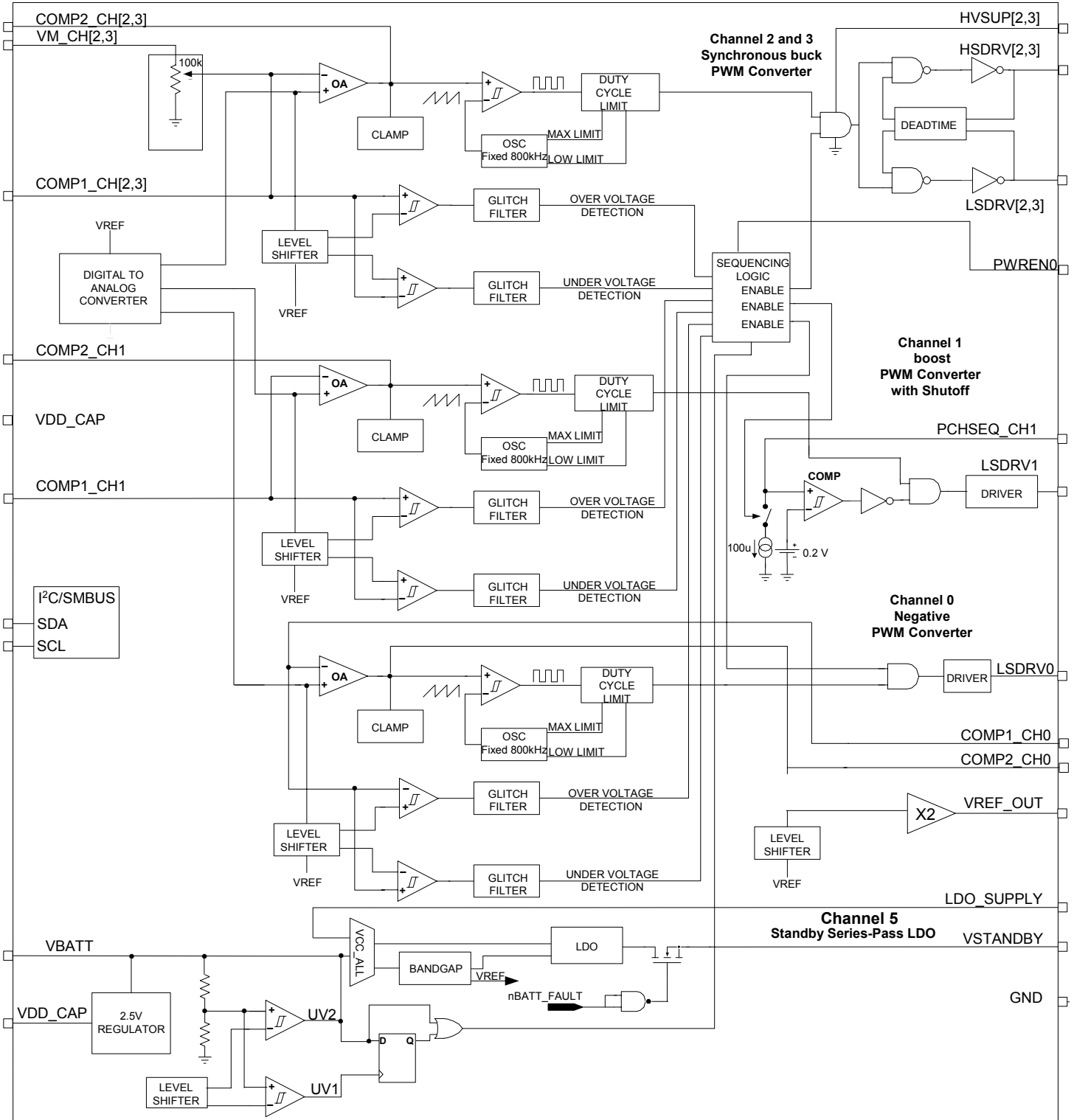

Figure 2 – Typical application schematic showing external circuitry necessary to configure the SMB110 channels as: step-up, step-down, and inverting outputs



## INTERNAL BLOCK DIAGRAM





<b>PIN DESCRIPTIONS</b>			
<b>Pin Number</b>	<b>Pin Type</b>	<b>Pin Name</b>	<b>Pin Description</b>
1	OUT	HEALTHY	The HEALTHY pin is an open drain output. High when all enabled output supplies are within the programmed levels. HEALTHY will ignore any disabled supply. There is a programmable glitch filter on the under-voltage and over-voltage sensors so that short transients outside of the limits will be ignored by HEALTHY. When used this pin should be pulled high by an external pull-up resistor.
2	I/O	SDA	SDA (Serial Data) is an open drain bi-directional pin used as the I <sup>2</sup> C data line. SDA must be tied high through a pull-up resistor.
3	IN	SCL	SCL (Serial Clock) is an open drain input pin used as the I <sup>2</sup> C clock line. SCL must be tied high through a pull-up resistor.
4	OUT	VREF_OUT	The VREF_OUT (Voltage Reference) pin is a precision reference output. When an inverting output is used, this pin acts as a level shifting reference for the feedback circuitry. When the inverting output is not used, this pin may be used as a programmable reference.
5	IN	COMP1_CH0	COMP1_CH0 (Channel 0 primary Compensation) pin is the primary feedback input of the inverting controller.
6	IN	COMP2_CH0	COMP2_CH0 (Channel 0 secondary Compensation) pin is the second feedback input of the inverting controller
7	OUT	LSDRV_CH0	The LSDRV_CH0 (Channel 0 Low-side Driver) pin is the switching node of the inverting buck-boost controller. The output of this pin should be attached to the gate of an external p-channel MOSFET driver.
8	IN	HOST_RESET	The HOST_RESET pin is an active high reset input. When this pin is asserted high, the nRESET output will immediately go low. When HOST_RESET is brought low, nRESET will go high after a programmed reset delay.
9	CAP	VBATT_CAP	The VBATT_CAP (VBATT Capacitor) pin is an external capacitor input used to filter the internal supply.
10	PWR	VBATT	Power supply to part.
11	OUT	PCHSEQ_CH1	The PCHSEQ_CH1 (Channel 1 Sequence) pin is attached to an external p-channel MOSFET and is used to enable the corresponding channel 1 boost controller. PCHSEQ_CH1 uses an internal 100 $\mu$ A current sink for sequencing. This pin should be pulled high through a parallel RC connection.
12	IN	COMP1_CH1	The COMP1_CH1 (Channel 1 primary Compensation) pin is the primary compensation input of the channel 1 boost controller.
13	IN	COMP2_CH1	The COMP2_CH1 (Channel 1 secondary Compensation) pin is the second compensation input of the channel 1 boost controller.

**PIN DESCRIPTIONS**

Pin Number	Pin Type	Pin Name	Pin Description
14	OUT	nRESET	The nRESET (Reset) pin is an active low open drain output. Active when the SMB110 is powered up. Remains low for a user programmable period of 25, 50, 100, or 200 ms after all enabled supplies have exceeded their programmed thresholds. When used, this pin should be pulled high by an external pull up resistor.
15	PWR	DRVGND	DRVGND (Driver Ground). Each DRVGND pin should be attached externally to ground through a short wide wire.
16	OUT	LSDRV_CH1	The LSDRV_CH1 (Channel 1 Low-side Driver) pin is the lower switching node of the synchronous boost controller. This pin attaches to an external n-channel MOSFET
17	OUT	LSDRV_CH2	The LSDRV_CH2 (Channel 2 Low-side Driver) pin is the lower switching node of the channel 2 synchronous buck controller. Attaches to the gate of n-channel MOSFET.
18	PWR	HVSUP2	Supply for Channel 2 buck driver.
19	OUT	HSDRV_CH2	The HSDRV_CH2 (Channel 2 High-side Driver) pin is the upper switching node of the channel 2 synchronous buck controller. Attach to the gate of p-channel MOSFET. A delay exists between the assertion of HSDRV_CH2 and assertion of LSDRV_CH2 to prevent excessive current flow during switching.
20	IN	COMP2_CH2	The COMP2_CH2 (Channel 2 secondary Compensation) pin is the secondary compensation input of the channel 2 buck controller.
21	IN	COMP1_CH2	The COMP1_CH2 (Channel 2 primary Compensation) pin is the primary compensation input of the channel 2 buck controller. Each pin is internally connected to a programmable resistor divider.
22	IN	VM_CH2	The VM_CH2 (Channel 2 Voltage Monitor) pin connects the channel 6 controller output. Internally the VM_CH2 pin connects to an internal programmable resistor divider.
23	PWR	LDO_SUPPLY	The LDO_SUPPLY pin powers the 3.3V VSTANDBY LDO output. The LDO_SUPPLY pin should be connected to the output of a boost output (usually the intermediate bus). When the battery voltage drops below the UV1 threshold, this pin will no longer supply the LDO. Do not apply a voltage in excess of the recommended input voltage to this pin.
24	OUT	VSTANDBY	The VSTANDBY (Voltage Standby) pin is a 3.3V LDO output. VSTANDBY is supplied from the output of the intermediate bus through the LDO_SUPP pin. When PWR_FAIL is asserted an internal analog multiplexer will power VSTANDBY directly from the VBATT pin.
25	OUT	LSDRV_CH3	The LSDRV_CH3 (Channel 3 Low-side Driver) pin is the lower switching node of the channel 3 synchronous buck controller. Attaches to the gate of n-channel MOSFET.
26	PWR	HVSUP3	Supply for Channel 3 buck driver.

**PIN DESCRIPTION**

Pin Number	Pin Type	Pin Name	Pin Description
27	OUT	HSDRV_CH3	The HSDRV_CH3 (Channel 3 High-side Driver) pin is the upper switching node of the channel 3 synchronous buck controller. Attach to the gate of p-channel MOSFET. A delay exists between the assertion of HSDRV_CH3 and assertion of LSDRV_CH3 to prevent excessive current flow during switching.
28	IN	PWREN0	The PWREN0 (Power Enable 0) pin is a programmable input used to enable (disable) selected supplies. When unused this pin should be tied to a solid logic level.
29	IN	COMP2_CH3	The COMP2_CH3 (Channel 3 secondary Compensation) pin is the secondary compensation input of the channel 3 buck controller.
30	IN	COMP1_CH3	The COMP1_CH3 (Channel 3 primary Compensation) pin is the primary compensation input of the channel 3 buck controller. Each pin is internally connected to a programmable resistor divider.
31	IN	VM_CH3	The VM_CH3 (Channel 3 Voltage Monitor) pin connects the channel 3 controller output. Internally the VM_CH3 pin connects to an internal programmable resistor divider.
32	PWR	GND	The GND pin should be connected to the common ground plane through a short fat wire.
PAD	PWR	GND	The exposed metal pad should be attached to ground.





**PACKAGE AND PIN DESCRIPTION**

Top view  
**SMB110**  
 5mm x 5mm QFN-32

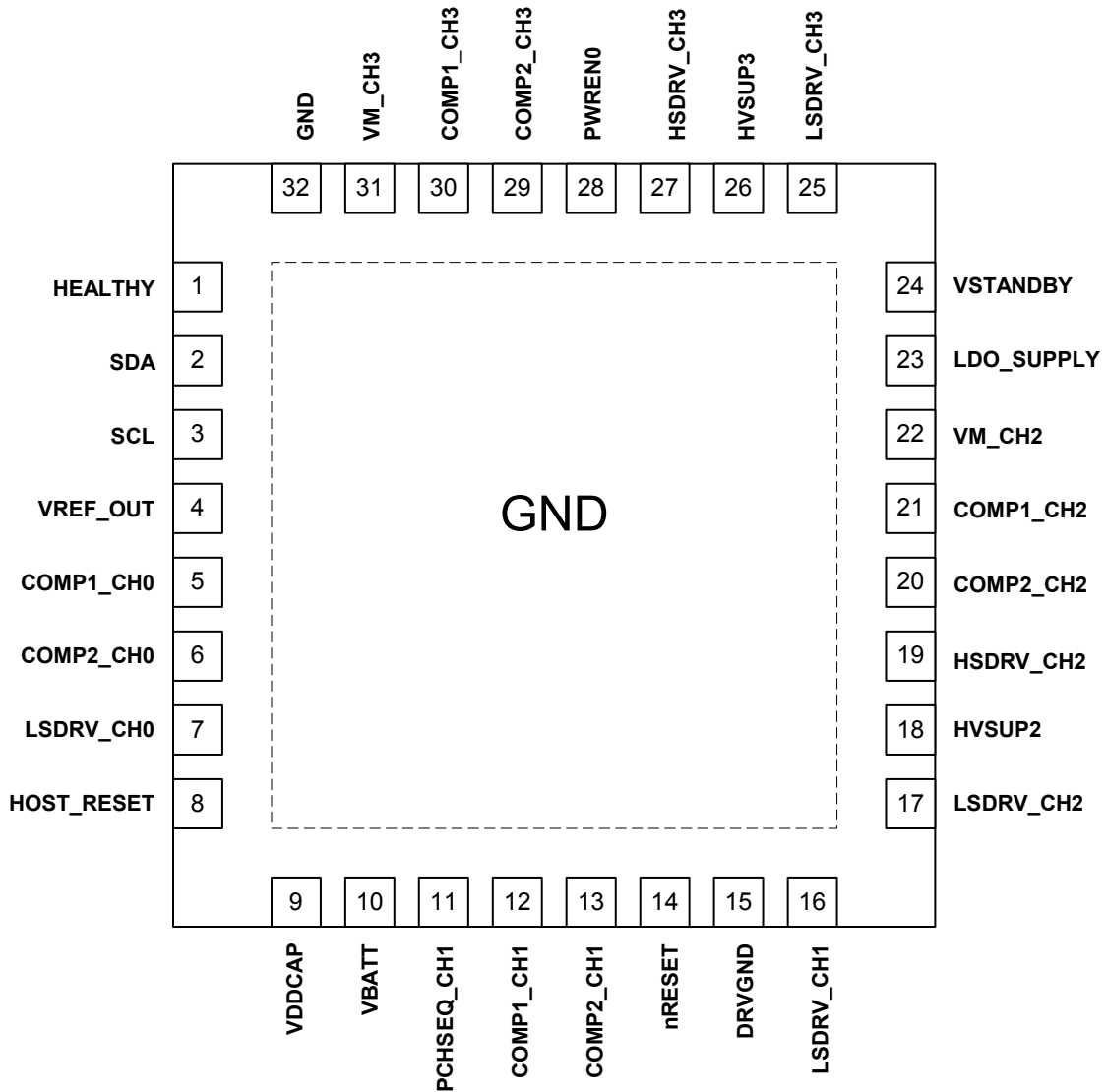



**ABSOLUTE MAXIMUM RATINGS**

Temperature Under Bias ..... -55°C to +125°C  
 Storage Temperature..... -65°C to +150°C  
 Terminal Voltage with Respect to GND:  
 VBATT Supply Voltage ..... -0.3V to +6.5V  
 HVSUP Supply Voltage ..... -0.3V to +6.5V  
 LDO\_SUPPLY ..... -0.3V to +6.5V  
 All Others ..... -0.3V to VBATT  
 Output Short Circuit Current ..... 100mA  
 Reflow Solder Temperature (30 secs)..... 260°C  
 Junction Temperature ..... 150°C  
 ESD Rating per JEDEC ..... 2000V  
 Latch-Up testing per JEDEC..... ±100mA

**RECOMMENDED OPERATING CONDITIONS**

Commercial Temperature Range..... 0°C to +70°C  
 VBATT Supply Voltage ..... 2.7V to +6.0V  
 HVSUP Supply Voltage..... 2.7V to +6.0V  
 LDO\_SUPPLY..... GND to +6.0V  
 All Others..... GND to VBATT

Package Thermal Resistance ( $\theta_{JA}$ )  
 32 Lead QFN. .... TBD  
 Moisture Classification Level 3 (MSL 3) per J-STD- 020

**RELIABILITY CHARACTERISTICS**

Data Retention ..... 100 Years  
 Endurance..... 100,000 Cycle  
 Temperature Range ..... 0°C to +70°C

Note - The device is not guaranteed to function outside its operating rating. Stresses listed under Absolute Maximum Ratings may cause permanent damage to the device. These are stress ratings only and functional operation of the device at these or any other conditions outside those listed in the operational sections of the specification is not implied. Exposure to any absolute maximum rating for extended periods may affect device performance and reliability. Devices are ESD sensitive. Handling precautions are recommended.

**DC OPERATING CHARACTERISTICS**

(Over recommended operating conditions, unless otherwise noted. All voltages are relative to GND.)

Symbol	Parameter	Conditions	Min	Typ	Max	Unit
VBATT	Input supply voltage	Input supply voltage (operational)	2.7		6.0	V
V <sub>LDO_SUPP</sub>	Linear regulator supply voltage	Internally multiplexed with VBATT	2.7		6.0	V
V <sub>HVSUP</sub>	Buck driver supply voltage	Gate drive voltage	2.7		6.0	V
V <sub>UVLO</sub>	Undervoltage lockout	VBATT rising		2.2		V
		VBATT falling		2.0		
I <sub>DD-MONITOR</sub>	Monitoring current	All voltage inputs monitored. No supplies switching, VBATT at 4.2V, LDO on with no output enabled			330	µA
I <sub>SD</sub>	Switching current for one output enabled	Current drawn when one output enabled		1.2		mA
I <sub>DD-</sub>	Total current all channels switching. <sup>1</sup>	VBATT at 4.2V, LDO on with no load			2.2	mA
V <sub>REF(INT)</sub>	Internal voltage reference		0.995		1.005	V
<b>Oscillator</b>						
f <sub>OSC</sub>	Oscillator frequency			800		kHz
Δf <sub>OSC</sub>	Oscillator frequency accuracy		-10		+10	%
O <sub>PP</sub>	Oscillator peak to peak <sup>2</sup> voltage			1		V
Δf <sub>SV</sub>	Frequency stability for voltage			0.1		%/V
Δf <sub>ST</sub>	Frequency stability for temperature			0.04		%/°C

**DC OPERATING CHARACTERISTICS (CONTINUED)**

(Over recommended operating conditions, unless otherwise noted. All voltages are relative to GND.)

Symbol	Parameter	Conditions	Min	Typ	Max	Unit
<b>Error Amplifier</b>						
V <sub>ACC</sub>	Threshold Voltage accuracy			0.2		%
TS	Temperature stability			0.2		%
A <sub>VOL</sub>	Open loop voltage Gain	At DC		60		dB
BW	Frequency bandwidth	At AV=0 dB		30		MHz
I <sub>SOURCE</sub>	Output source current	At 0.5V		20		μA
I <sub>SINK</sub>	Output sink current	At 0.5V		800		μA
<b>LDO</b>						
V <sub>OUT</sub>	Nominal output voltage	LDO_SUPPLY = 4.2V, I <sub>LOAD</sub> =0A		3.3		V
ΔV <sub>OUT</sub>	Output voltage accuracy	Percent of 3.3V output @ 10mA, LDO_SUPPLY = 4.2V		0.3		%
ΔV <sub>LOAD</sub>	Load regulation error			0.3		%/V
ΔV <sub>LINE</sub>	Line regulation error	No load		0.17		%/mA
PSRR	Power supply rejection ratio	20log(V <sub>out</sub> /V <sub>in</sub> ) @ 10kHz		50		dB
I <sub>Q</sub>	Quiescent current	VBATT = 4.2V, I <sub>LOAD</sub> =0A		50		μA
V <sub>DO</sub>	Dropout voltage	I <sub>OUT</sub> = 1 mA		20		mV
		I <sub>OUT</sub> = 5 mA		100		
		I <sub>OUT</sub> = 10 mA		200		
		I <sub>OUT</sub> = 15 mA		300		
		I <sub>OUT</sub> = 20 mA		400		
I <sub>LIMIT</sub>	Maximum output current				40	mA
V <sub>N</sub>	Output Noise voltage	Peak to peak		1		mV
<b>Inverting Output Block Channel 0</b>						
V <sub>OUT</sub>	Programmable voltage set point range	VBATT=4.2V, I <sub>LOAD</sub> =0	-35		-0.5	V
ΔV <sub>OUT</sub>	Output accuracy	Excluding external resistor divider accuracy		0.5		%
V <sub>COMP1</sub>	Feedback voltage reference	COMP1 pin		1.0		V
Δ V <sub>COMP1</sub>	Feedback voltage reference accuracy	COMP1 pin	-0.2		+0.2	%
R <sub>ON</sub>	LSDRV Output ON resistance	R <sub>OH</sub>		17		Ω
		R <sub>OL</sub>		3		
D.C.	LSDRV Duty Cycle	High	85		95	%
		Low	5		15	
V <sub>REF_OUT</sub>	Level shift voltage reference	VREF_OUT pin programmable in 8mV steps	1		2	V



<b>DC OPERATING CHARACTERISTICS (CONTINUED)</b>						
<b>(Over recommended operating conditions, unless otherwise noted. All voltages are relative to GND.)</b>						
<b>Symbol</b>	<b>Parameter</b>	<b>Conditions</b>	<b>Min</b>	<b>Typ</b>	<b>Max</b>	<b>Unit</b>
<b>Inverting Output Block Channel 0 (Continued)</b>						
$I_{REF\_OUT}$	VREF_OUT source current	VREF_OUT = 1.5V			100	$\mu$ A
ML	Minimum load <sup>3</sup>	L=33 $\mu$ F, V <sub>O</sub> =-7.5V, V <sub>IN</sub> =4.2V, V <sub>D</sub> =0.3V		10.1		k $\Omega$
<b>Boost Output Block Channel 1</b>						
V <sub>OUT</sub>	Programmable voltage set point range	VBATT=4.2V, I <sub>LOAD</sub> =0	4.5		35	V
$\Delta V_{OUT}$	Output accuracy	Excluding external resistor divider accuracy		0.5		%
R <sub>DRVH</sub>	HSDRV ON resistance	Output high		17		$\Omega$
		Output low		3		
D.C.	Duty Cycle	High	85		95	%
		Low	5		15	
V <sub>COMP1</sub>	Feedback voltage reference	COMP1 pin Programmable in 4mV steps		1.0		V
$\Delta V_{COMP1}$	Feedback voltage reference accuracy	COMP1 pin	-0.5		+0.5	%
ML	Minimum load <sup>4</sup>	L=33 $\mu$ F, V <sub>O</sub> =12V, V <sub>IN</sub> =4.2V, V <sub>D</sub> =0.3V		29		k $\Omega$
I <sub>PCHSEQ</sub>	PCHSEQ sink current		50		100	$\mu$ A
EN <sub>TH</sub>	Enable threshold	Voltage on PCHSEQ pin when LSDRV output is enabled		200		mV
<b>Buck Output Block Channels 2 and 3</b>						
V <sub>OUT</sub>	Voltage nominal set point range	VBATT = 4.2V, I <sub>LOAD</sub> = 0	0.5		3.8	V
		VBATT = 6.0V, I <sub>LOAD</sub> = 0	0.6		5.4	
$\Delta V_{OUT}$	Output accuracy	Including internal resistor divider		0.5		%
R <sub>DRVH</sub>	HSDRV ON resistance	Output high		8		$\Omega$
		Output low		8		
R <sub>DRVL</sub>	LSDRV ON resistance	Output high		17		
		Output low		3		
V <sub>COMP1</sub>	Feedback voltage reference	COMP1 pin Programmable in 4mV steps		1.0		V
$\Delta V_{COMP1}$	Feedback voltage reference accuracy	COMP1 pin	-0.5		+0.5	mV
D.C.	Duty Cycle	High	85		95	%
		Low	5		15	



<b>DC OPERATING CHARACTERISTICS (CONTINUED)</b>						
<b>(Over recommended operating conditions, unless otherwise noted. All voltages are relative to GND.)</b>						
<b>Symbol</b>	<b>Parameter</b>	<b>Conditions</b>	<b>Min</b>	<b>Typ</b>	<b>Max</b>	<b>Unit</b>
<b>Miscellaneous</b>						
V <sub>IH</sub>	Input high voltage			0.9xVDD_CAP		V
V <sub>IL</sub>	Input low voltage			0.1xVDD_CAP		V
V <sub>OL</sub>	Open drain outputs	I <sub>SINK</sub> = 1mA	0		0.4	V
I <sub>OL</sub>	Output low current		0		1.0	mA
<b>Programmable Monitoring Thresholds</b>						
V <sub>PUV1</sub>	Programmable UV1 threshold	Programmable UV1 threshold voltage measured on VBATT pin in 150 mV increments	2.55		3.60	V
ΔV <sub>PUV1</sub>	UV1 accuracy		-20		+20	mV
V <sub>PUV2</sub>	Programmable UV2 threshold	Programmable UV2 threshold voltage measured on VBATT pin in 150 mV increments	2.55		3.60	V
ΔV <sub>PUV2</sub>	UV2 accuracy		-20		+20	mV
P <sub>UVTH</sub>	Programmable under voltage threshold	For channels 1-3. Relative to nominal set point voltage		-5		%
				-10		
				-15		
				-20		
P <sub>OVTH</sub>	Programmable over voltage threshold	For channels 1-3. Relative to nominal set point voltage		+5		%
				+10		
				+15		
				+20		
P <sub>UVTH</sub>	Programmable under voltage threshold <sup>5</sup>	For channel 0. V <sub>O</sub> =-7.5V, R1=392K, R2=33.2K		-6.2		%
				-12.4		
				-18.6		
				-24.8		
P <sub>OVTH</sub>	Programmable over voltage threshold <sup>6</sup>	For channel 0. V <sub>O</sub> =-7.5V, R1=392K, R2=33.2K		+6.2		%
				+12.4		
				+18.6		
				+24.8		



<b>AC OPERATING CHARACTERISTICS</b>						
<b>(Over recommended operating conditions, unless otherwise noted. All voltages are relative to GND.)</b>						
<b>Symbol</b>	<b>Parameter</b>	<b>Conditions</b>	<b>Min</b>	<b>Typ</b>	<b>Max</b>	<b>Unit</b>
$t_{PPTO}$	Programmable power-On sequence timeout period.	Programmable power-On sequence position to sequence position delay.	1.3	1.5	1.7	ms
			10.6	12.5	14.4	
			21.3	25	28.8	
			42.5	50	57.5	
$t_{DPOFF}$	Programmable power-off sequence timeout period.	Programmable power-off sequence position to sequence position delay.	1.3	1.5	1.7	ms
			10.6	12.5	14.4	
			21.3	25	28.8	
			42.5	50	57.5	
$t_{PRTO}$	Programmable reset time-out delay	Programmable time following assertion of last supply before nRESET pin is released high.	21.3	25	28.8	ms
			42.5	50	57.5	
			85	100	115	
			170	200	230	
$t_{PST}$	Programmable sequence termination period	Time between active enable in which corresponding outputs must exceed there programmed under voltage threshold. If exceeded, a force shutdown will be initiated.		OFF		ms
			42.5	50	57.5	
			85	100	115	
			170	200	230	
$t_{PGF}$	Programmable glitch filter	Period for which fault must persist before fault triggered actions are taken. Present on all buck, boost, and inverting supplies.		0		$\mu$ s
			6.8	8	9.2	
$SR_{REF}$	Programmable slew rate reference	Adjustable slew rate factor proportional to output slew rate.	340	400	460	V/s
			170	200	230	
			85	100	115	
			56.7	66.7	76.7	
			42.5	50	57.5	
			28.3	33.3	38.3	
			21.3	25	28.8	
			17.0	20	23	



<b>AC OPERATING CHARACTERISTICS (CONTINUED)</b>						
<b>(Over recommended operating conditions, unless otherwise noted. All voltages are relative to GND.)</b>						
<b>Symbol</b>	<b>Parameter</b>	<b>Conditions</b>	<b>Min</b>	<b>Typ</b>	<b>Max</b>	<b>Unit</b>
<b>Inverting Output Block Channel 0</b>						
$t_{RH}$	HS Driver output rise time	$C_G=100\mu F, V_{BATT}=4.2V$		10		ns
$t_{FH}$	HS Driver output fall time	$C_G=100\mu F, V_{BATT}=4.2V$		10		ns
<b>Boost Output Block Channel 1</b>						
$t_{RL}$	LS Driver output rise time	$C_G=100\mu F, V_{BATT}=4.2V$		10		ns
$t_{FL}$	LS Driver output fall time	$C_G=100\mu F, V_{BATT}=4.2V$		10		ns
<b>Buck Output Block Channels 2 and 3</b>						
$t_{RL}$	LS Driver output rise time	$C_G=100\mu F, V_{BATT}=4.2V$		10		ns
$t_{FL}$	LS Driver output fall time	$C_G=100\mu F, V_{BATT}=4.2V$		10		ns
$t_{RH}$	HS Driver output rise time	$C_G=100\mu F, V_{BATT}=4.2V$		15		ns
$t_{FH}$	HS Driver output fall time	$C_G=100\mu F, V_{BATT}=4.2V$		5		ns
$t_{DT}$	Driver non-overlap delay	High to low transition on HSDRV			20	ns
		Low to high transition on buck HSDRV			10	

1. The total current drawn when all supplies are switching will not equal the sum of the buck, boost, and inverting buck-boost channels current consumption when switching independently. This is due to current overhead to commence sequencing.

2. Guaranteed by design.

3. The minimum load for the Inverting Boost-Buck channel is defined by the following equation: where  $V_o$  = Programmed output voltage,  $V_{IN}$  =P-Channel MOSFET source voltage,  $L$  = inductance,  $V_d$  = forward diode drop (0.6V silicon, 0.3V Schottky). Lesser values may exist

$$R_{max} = \frac{2 \cdot L \cdot V_{out} \cdot (V_{out} - V_d)}{V_{IN}^2 \cdot 1.25E-8}$$

4. The minimum load for Boost channels is defined by the following equation: where  $V_o$  = Programmed output voltage,  $V_{IN}$  =P-Channel MOSFET source voltage,  $L$  = inductance, and  $V_d$  = forward diode drop (0.6V silicon, 0.3V Schottky). Lesser values may exist

$$R_{max} = \frac{2 \cdot L \cdot V_{out} \cdot (V_{out} - V_{IN} + V_d)}{V_{IN}^2 \cdot 1.25E-8}$$

5. The Channel 0 programmable under voltage setting is calculated from the following formula: where  $V_{REF\_OUT}$  is the voltage o the  $V_{REF\_OUT}$  pin and  $R_1$  and  $R_2$  are the upper and lower resistors in the external voltage divider,  $n$  corresponds to the available user programmable settings

$$Ch\ 0\ P_{UVTH} = -100n \left[ 1 - \frac{V_{REF\_OUT} - .95(1+R_2/R_1)}{V_{REF\_OUT} - (1+R_2/R_1)} \right] \% \ n = 1,2,3,4$$

6. The Channel 0 programmable over voltage setting is calculated from the following formula: where  $V_{REF\_OUT}$  is the voltage o the  $V_{REF\_OUT}$  pin and  $R_1$  and  $R_2$  are the upper and lower resistors in the external voltage divider,  $n$  corresponds to the available user programmable settings

$$Ch\ 0\ P_{OVTH} = 100n \left[ 1 - \frac{V_{REF\_OUT} - .95(1+R_2/R_1)}{V_{REF\_OUT} - (1+R_2/R_1)} \right] \% \ n = 1,2,3,4$$



**I<sup>2</sup>C-2 WIRE SERIAL INTERFACE AC OPERATING CHARACTERISTICS –100 kHz**

(Over recommended operating conditions, unless otherwise noted. All voltages are relative to GND.)

Symbol	Description	Conditions	100kHz			Units
			Min	Typ	Max	
f <sub>SCL</sub>	SCL clock frequency		0		100	kHz
T <sub>LOW</sub>	Clock low period		4.7			μs
T <sub>HIGH</sub>	Clock high period		4.0			μs
t <sub>BUF</sub>	Bus free time	Before new transmission - Note 1/	4.7			μs
t <sub>SU:STA</sub>	Start condition setup time		4.7			μs
t <sub>HD:STA</sub>	Start condition hold time		4.0			μs
t <sub>SU:STO</sub>	Stop condition setup time		4.7			μs
t <sub>AA</sub>	Clock edge to data valid	SCL low to valid SDA (cycle n)	0.2		3.5	μs
t <sub>DH</sub>	Data output hold time	SCL low (cycle n+1) to SDA change	0.2			μs
t <sub>R</sub>	SCL and SDA rise time	Note 1/			1000	ns
t <sub>F</sub>	SCL and SDA fall time	Note 1/			300	ns
t <sub>SU:DAT</sub>	Data in setup time		250			ns
t <sub>HD:DAT</sub>	Data in hold time		0			ns
TI	Noise filter SCL and SDA	Noise suppression		100		ns
t <sub>WR_CONFIG</sub>	Write cycle time config	Configuration registers			10	ms
t <sub>WR_EE</sub>	Write cycle time EE	Memory array			5	ms

Note: 1/ - Guaranteed by Design.

**TIMING DIAGRAMS**

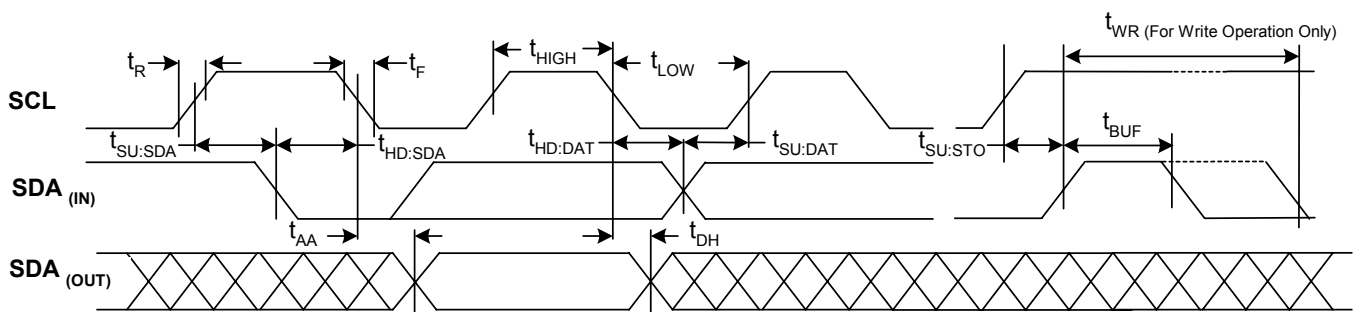

Figure 4 – I<sup>2</sup>C timing diagram





**EFFICIENCY GRAPHS**

**Channel 0 Inverting -7.5V**

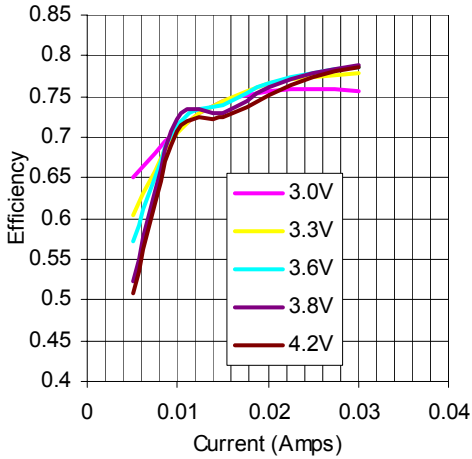

**Channel 1 Boost 6.0V**

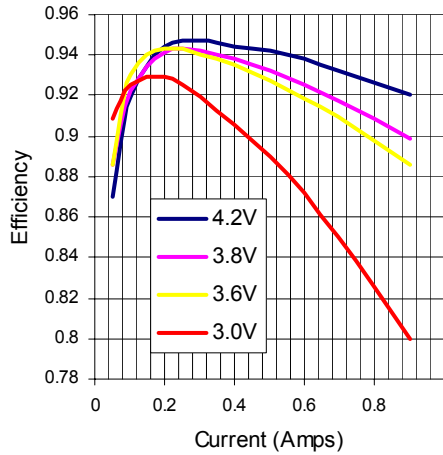

**Channel 1 Boost 12V**

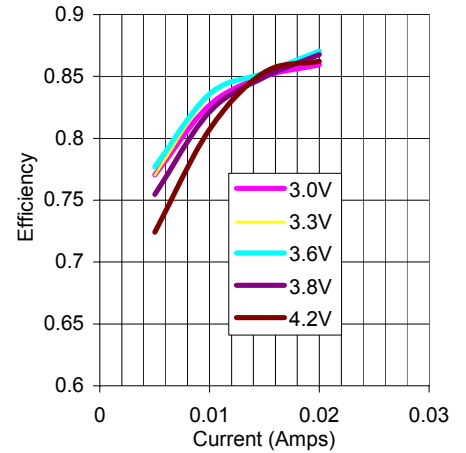

**Channel 3 (Ch 1 Boost + Buck) 5.0 Volts**

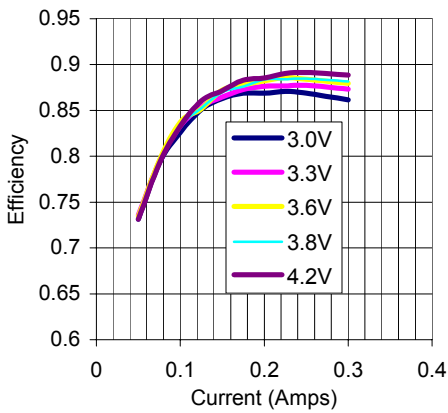

**Channel 3 (Ch 1 Boost + Buck) 3.0 Volts**

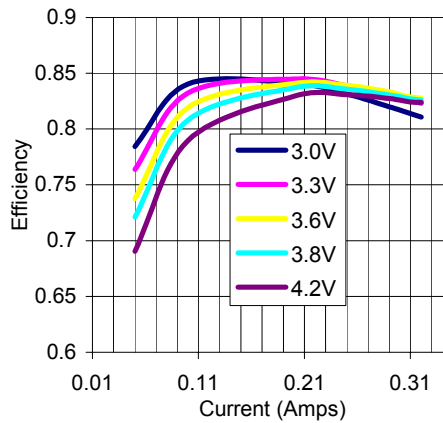

**Channel 2 Buck 1.2V**

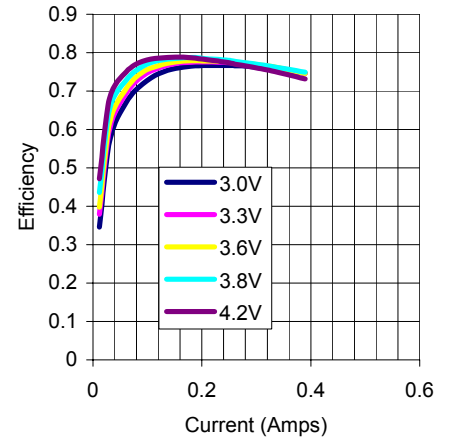

**Channel 2 Buck 2.5 Volts**

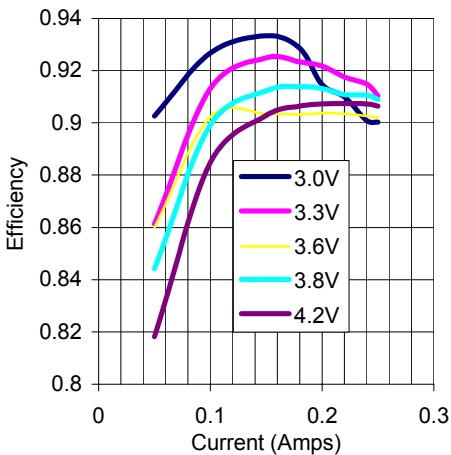

(All measurements are taken at 25°C, and are based on the Applications Schematic.)



**TRANSIENT RESPONSE**

**CHANNEL 2 BUCK TRANSIENT RESPONSE**

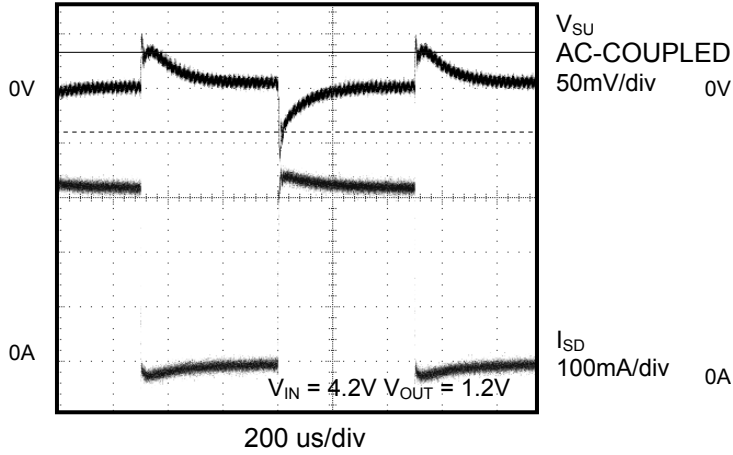

**CHANNEL 2 BUCK TRANSIENT RESPONSE**

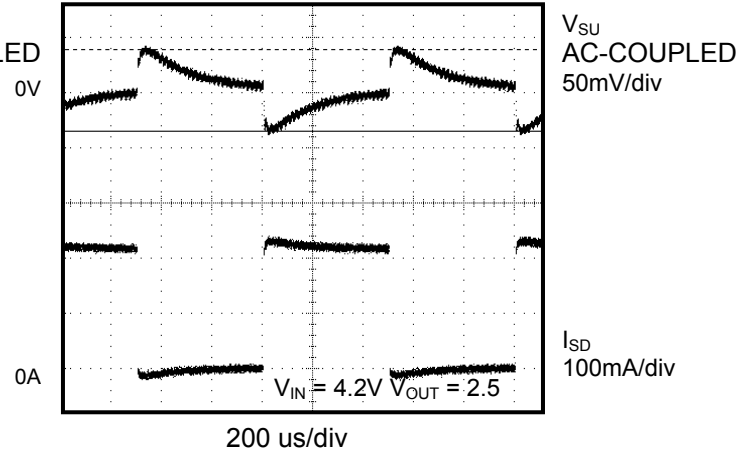

**CHANNEL 3 BUCK TRANSIENT RESPONSE**

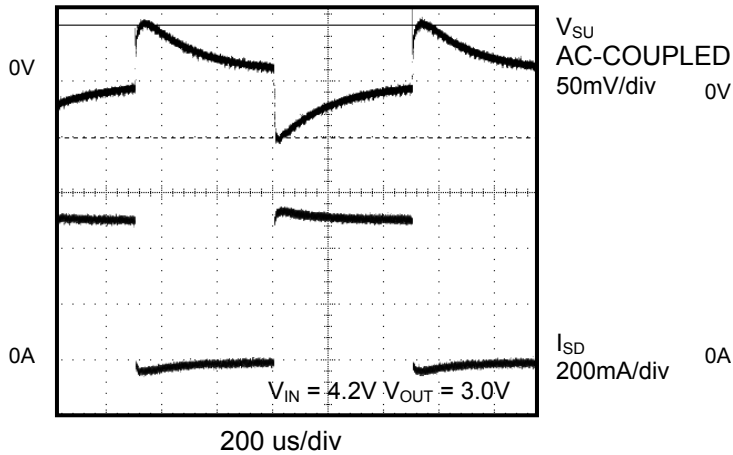

**CHANNEL 3 BUCK TRANSIENT RESPONSE**

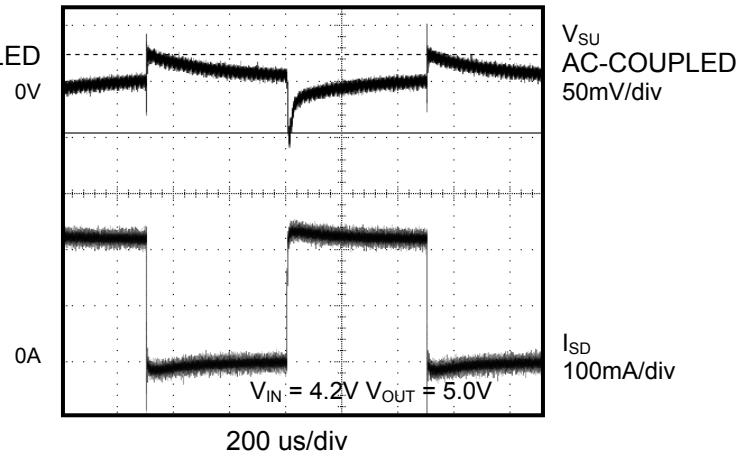

**CHANNEL 0 INVERTING TRANSIENT RESPONSE**

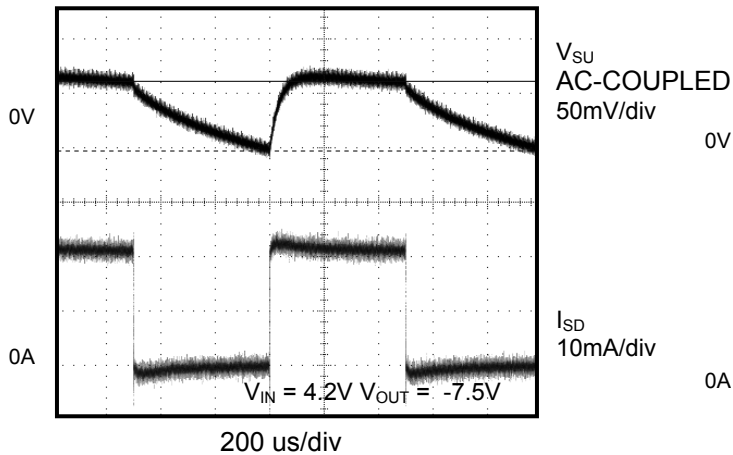

**CHANNEL 1 STEP UP TRANSIENT RESPONSE**

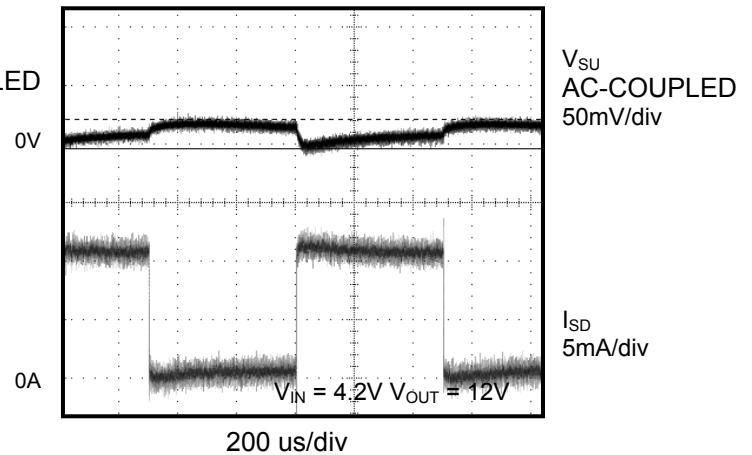

(All measurements are taken at 25°C, and are based on the Applications Schematic.)



**TIMING DIAGRAMS: POWER-ON SEQUENCE**

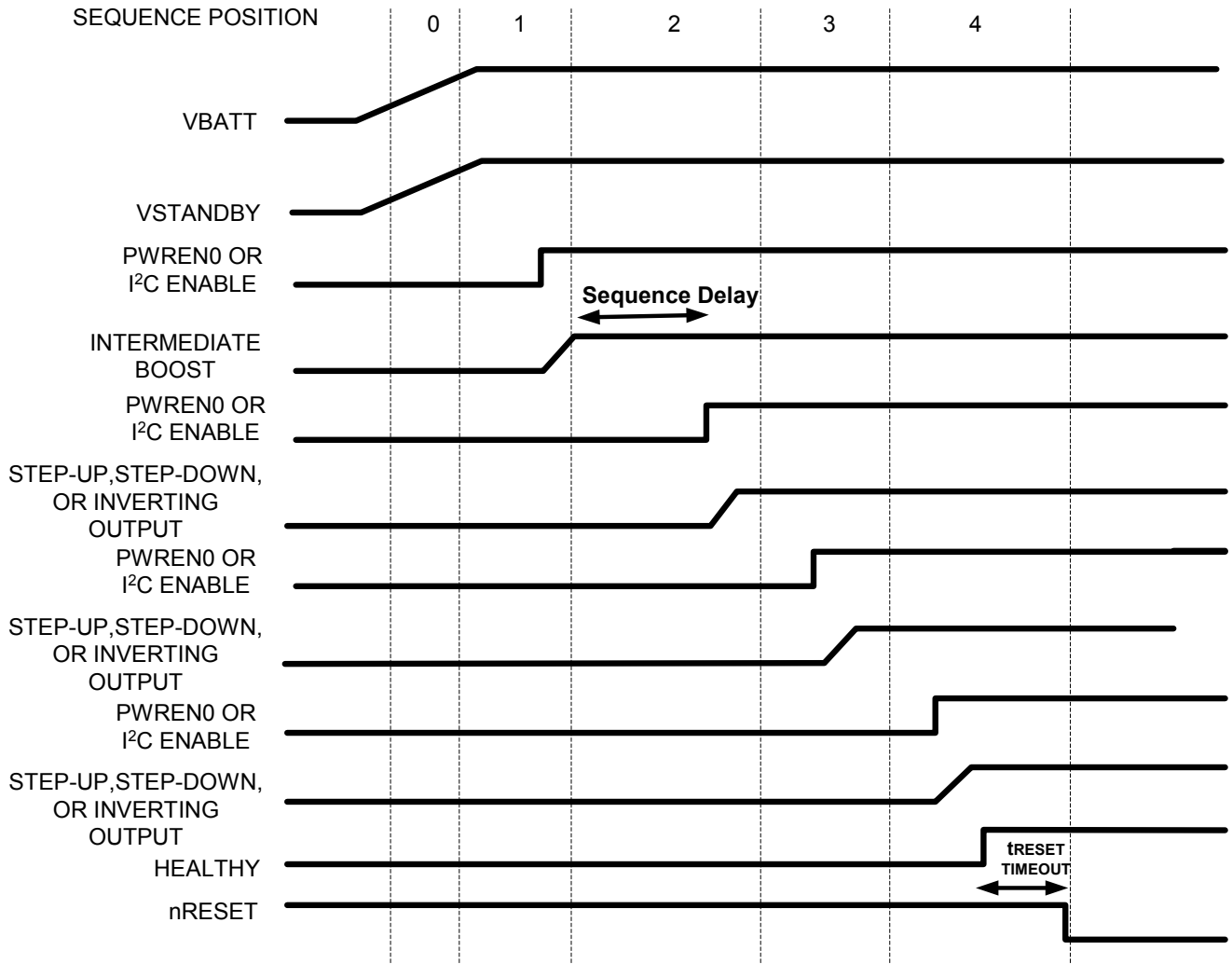

Figure 5 – SMB110 power-On sequence. Any PWM channel may be enabled or disabled through an I<sup>2</sup>C command or by the PWREN0 pin.



## APPLICATIONS INFORMATION

### DEVICE OPERATION

#### POWER SUPPLY

The SMB110 can be powered from an input voltage between 2.7-6.0 volts applied between the VBATT pin and ground. The input voltage applied to the VBATT pin is internally regulated and used as an internal VBATT supply. The VBATT pin is monitored by an UnderVoltage Lockout (UVLO) circuit, which prevents the device from turning on when the voltage at this node is less than the UVLO threshold.

#### POWER-ON/OFF CONTROL

The outputs on the SMB110 can be turned on in one of three ways: first a general purpose enable input pin PWREN0, second an I<sup>2</sup>C **Power on** command can be issued, or third if a programmable bit is set to initiate the power on process when the UVLO threshold is exceeded. a restart will only occur if the power-on pin is toggled or an I<sup>2</sup>C **Power on** command is issued.

#### ENABLE

Once a power on command has been issued, the power on process can be controlled by means of an enable signal. Each channel can be controlled by one of four enable signals and the assignment type can be mixed and matched for each of the four channels. The enable signal can stall the power-on process until the enable is valid, or disable a controller once all supplies have been enabled. There are two ways to generate the enable signal; the first approach allows the enable signal to be assigned the PWREN0 pin, and the second approach allows the enable to be controlled by the contents of a volatile register that can be written to at any time. This volatile register will be automatically initialized once the UVLO threshold has been exceeded to a known programmed state.

#### POWER-ON SEQUENCING

Each channel on the SMB110 may be placed in any one of four unique sequence positions. To provide programmable order, the SMB110 navigates between these sequence positions using a feedback-based cascade-sequencing circuit. Cascade sequencing is the process in which each channel is continually compared against a programmable reference voltage until the voltage on the monitored channel exceeds the reference voltage, at which point an internal sequence position counter is incremented and the next sequence position is entered.

Once power-on sequencing has been initiated, automated sequencing may commence in one of three ways (Figure 7): normal sequencing, sequencing with

enable, and sequencing with channel bypass. In addition, each channel may be powered on in a manual mode, independent of the sequence position. The power-on sequencing mode selection is programmable over the I<sup>2</sup>C bus and stored in the non-volatile memory.

#### NORMAL CASCADE SEQUENCING

During *Normal Sequencing*, the sequence position counter is initialized to the first sequence position (position 1), each channel occupying this position then waits an individual programmable timeout period ( $t_{PPTO}$ ) of 1.5, 12.5, 25, or 50 ms. Once enabled, all channels occupying the first sequence position will begin a soft-start. As the output voltage of the channel is ramped up, it is monitored by a comparator based, user programmable, under-voltage threshold sensor. After this threshold is exceeded, indicating that the selected channel(s) have reached their nominal operating range the sequence position counter is incremented, and fault monitoring begins for that channel. Once all channels occupying the first sequence position have surpassed their under-voltage thresholds, the power-on delay for the next sequence position will begin. This process continues until all channels have been sequenced on and are above their under-voltage threshold.

#### SEQUENCING WITH ENABLE

During the *Sequencing With Enable* mode, sequencing commences as with the *Normal Sequencing*, except that prior to a channel beginning to soft-start, the enable corresponding to that channel must be asserted. In the event that the enable is not asserted, sequencing will halt indefinitely until a valid enable is provided. Once a valid enable is provided, a soft-start function will begin for that channel. This process will continue until all channels occupying the first sequence position are above their under-voltage settings, at which point the sequence position counter will be incremented.

#### SEQUENCING WITH CHANNEL BYPASS

When the *Sequencing With Channel Bypass* mode is selected, sequencing will commence as with the *Sequencing With Enable*, except that if the enable signal is not asserted by the end of the power-on delay period, that channel will be bypassed. If no other channels occupy the current sequence position, the sequence position counter will be incremented beginning the power-on delay for all channels in the next sequence position. Once a channel has been bypassed, it may still be enabled any time prior to a power off operation.

**APPLICATIONS INFORMATION (CONTINUED)****MANUAL MODE**

The SMB110 also provides a manual power-on mode in which each channel may be enabled individually irrespective of the state of other channels. In this mode, the enable has complete control over the channel, and all sequencing is ignored. In Manual mode channels will not be disabled in the event of a fault.

**POWER OFF OPTIONS****FORCE-SHUTDOWN**

When a battery fault occurs, a UV or OV is detected on any PWM channel, or an I<sup>2</sup>C force-shutdown command is issued, all channels will be immediately disabled.

**SEQUENCE TERMINATION TIMER**

At the beginning of each sequence position, an internal programmable timer will begin to time out. When this timer has expired, the SMB110 will automatically perform a force-shutdown operation. This timer is user programmable with a programmable sequence termination period ( $t_{PST}$ ) of 50,100,200 ms; this function can also be disabled.

**POWER OFF SEQUENCING**

The SMB110 has a power-off sequencing operation. During a power off operation the supplies will be powered off in the reverse order they were powered on in. During the power off sequencing, all enables are ignored.

When a power-off command is issued the SMB110 will set the sequence position counter to the last sequence position and disable that channel without soft-start control; once off, the power off delay for the channel(s) in the next to last sequence position will begin to timeout, after which that channel(s) will be disabled. This process will continue until all channels have been disabled and are off. The programmable power-off sequence timeout period ( $t_{DPOFF}$ ) can be set to 1.5, 12.5, 25, or 50 ms.

If a channel fails to turn off within the sequence termination period, the sequence termination timer will initiate a force shutdown, if enabled.

**MONITORING**

The SMB110 monitors all 4 PWM outputs for under-voltage (UV) and over-voltage (OV) faults. The monitored levels are user programmable, and may be set at 5,10, 15, and 20 percent of the nominal output voltage.

Each output possesses a glitch filter to ensure that short violations in the UV or OV settings will not result in a fault-triggered action. All glitch filters on the

SMB110 are user programmable and may be set to either 0 or 8  $\mu$ s.

In the event that one or more channels violate their respective UV/OV setting for a period exceeding that specified by the glitch filter, all channels (not set to Manual mode) can optionally be powered off and-or, the healthy pin can be triggered. The programmable power off conditions that may result from a threshold violation include the immediate power off all supplies (force-shutdown) or the sequence of all supplies off.

Monitoring is accomplished by a comparator-based approach, in which a programmable voltage reference is compared against the monitored signal. Each channel possesses a dedicated reference voltage generated by a programmable level shifting digital to analog converter. Each of which can be set from 0-1.0 volts in 4mV increments.

**BATTERY MONITORING**

The battery voltage is monitored for two user programmable UV settings via the VBATT pin

The SMB110 contains two user programmable voltage-monitoring levels, UV1 and UV2. Battery voltage, like all monitored voltages, is compared against a user programmable voltage set internally by a digital to analog converter.

Once the voltage on the VBATT pin has fallen below either of the programmable under voltage set points the SMB110 can be programmed to respond in one of three ways, it can perform: a power-off operation, a force-shutdown operation, or take no action. When programmed to perform a power-off or force-shutdown operation the SMB110 can optionally be programmed to latch the outputs off until an I<sup>2</sup>C power-on command is issued or immediately restart once the UV condition has been removed.

**OUTPUT VOLTAGE**

The PWM output voltages are set by a resistor divider from the output to the COMP1 node; see Figure 6. For the buck channels (Ch[2:3]), the voltage divider is internal to the part and programmable. The resistor divider may be set by adjusting a 100 k $\Omega$  resistor string with 8 taps from R1 = 20-90 k $\Omega$ . For the boost output (Ch1), the resistor divider is external and any appropriate value of R1 and R2 can be chosen. The reference voltage that sets the output is user programmable, and may be set anywhere from 0-1.0V in 4 mV increments for channels 1 to 3, channel 0 is fixed at 1.0V. The Channel 0 inverting output is set by the external resistor divider and the VREF\_OUT

**APPLICATIONS INFORMATION (CONTINUED)**

voltage, which varies from 1.0 – 2.0V in 8 mV increments

**LDO STANDBY VOLTAGE**

The SMB110 has an internal 3.3 volt Low Dropout (LDO) linear regulator. While the battery voltage is above the UV2 level this supply is powered from the LDO\_SUPPLY pin, however, when the battery voltage drops below the UV2 level the LDO supply voltage will be routed to the battery through an internal analog multiplexer. The LDO will continue to be supplied by the battery until the latched UV2 pin is released. The LDO will be disabled once the Battery voltage falls below the UV2 level.

**SOFT START**

The SMB110 provides a programmable soft-start function for all PWM outputs. The soft-start control limits the slew rate that each output is allowed to ramp up without the need for an external capacitor. The soft start slew rate is proportional to the product of the output voltage and a slew rate reference; see Figure 5. This global reference is programmable and may be set to 400,200,100,67,50,33,25, and 20 volts per second. The slew rate control can also be disabled on any channel not requiring the feature.

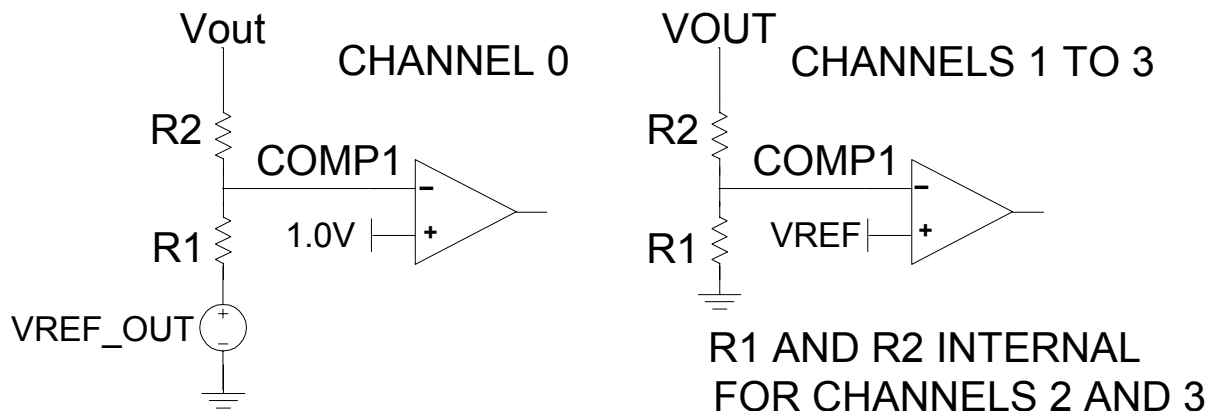

**Figure 6: The output voltage is set by the resistor divider. The resistor divider is internal for all buck channels. VREF is programmable from 0 to 1.0V in 4 mV increments and VREF\_OUT is programmable from 1.0 to 2.0V in 8 mV increments. All voltage references are programmable via the I<sup>2</sup>C interface.**



**APPLICATIONS INFORMATION (CONTINUED)**

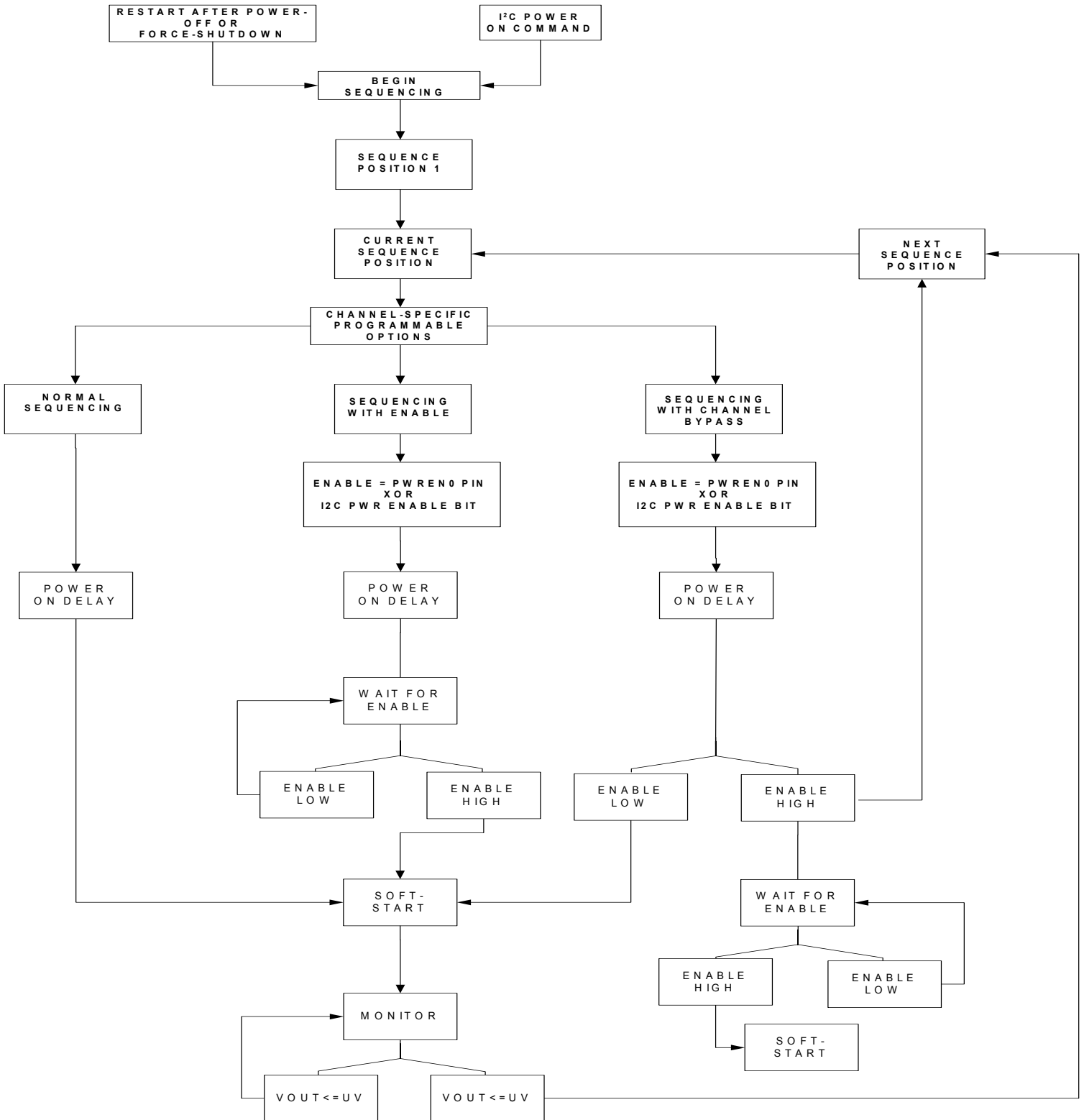

**Figure 7 – Power-on sequencing flow chart: There are three automated power-on sequencing modes, and a manual mode.**



## APPLICATIONS INFORMATION (CONTINUED)

### MINIMUM LOAD

The duty cycle is limited to a 10-90% range. Consequently, the boost channels require a minimum load to prevent over voltage conditions from occurring.

This may be overcome by attaching a resistor preload to the output that matches the minimum load requirements. This approach will result in a constant current consumption while the outputs are enabled. Alternatively, a zener diode (with a higher breakdown voltage than the output) can be connected across the output clamping the output voltage. This approach will not draw current when the load is enabled on the output.

### MARGINING

The SMB110 has two additional voltage settings for channels 0-3, margin high and margin low. The margin high and margin low voltage settings have the same voltage range as the controllers' nominal output voltage. These settings are stored in the configuration registers and are loaded into the voltage setting by margin commands issued via the I<sup>2</sup>C bus.

The margin command registers contain two bits for each channel that decode the commands to margin high, margin low, or control to the nominal setting. Therefore, any combination of margin high, margin low, and nominal control is allowed in the margining mode.

Once the SMB110 receives the command to margin the supply voltages, it begins adjusting the supply voltages to move toward the desired setting. When all channels are at their voltage setting, a bit is set in the margin status registers.

**Note: Configuration writes or reads of registers should not be performed while margining.**

A typical application utilizing the margining functionality is depicted in Figure 8. When used with a boost controller setup as a constant current white LED driver, margining can be used to adjust the current through the LED chain as an adjustable brightness control.

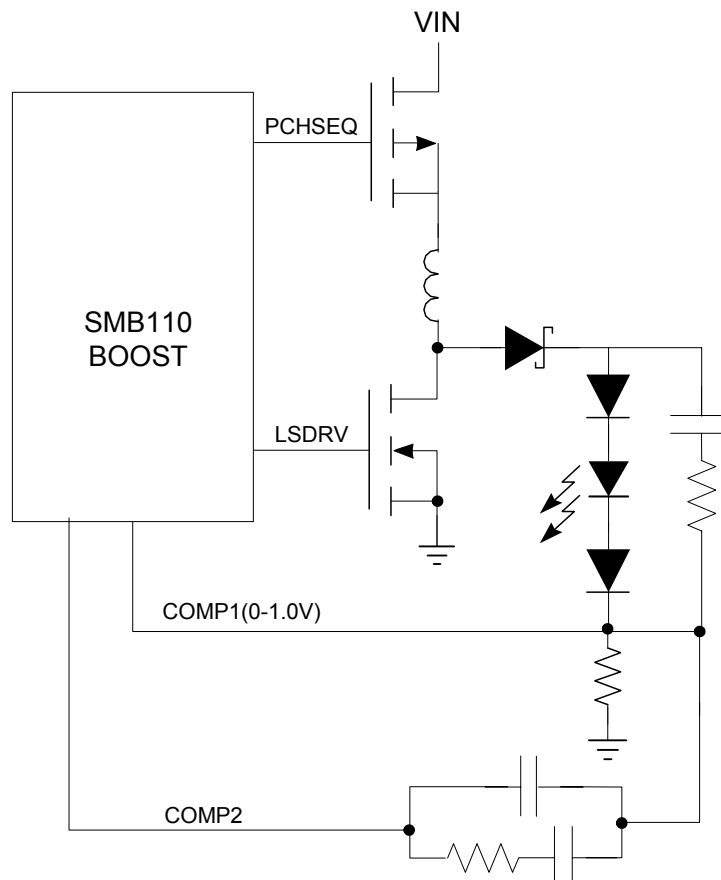

Figure 8 – Boost configured as a constant current white LED driver with adjustable current capabilities.





## APPLICATIONS INFORMATION (CONTINUED)

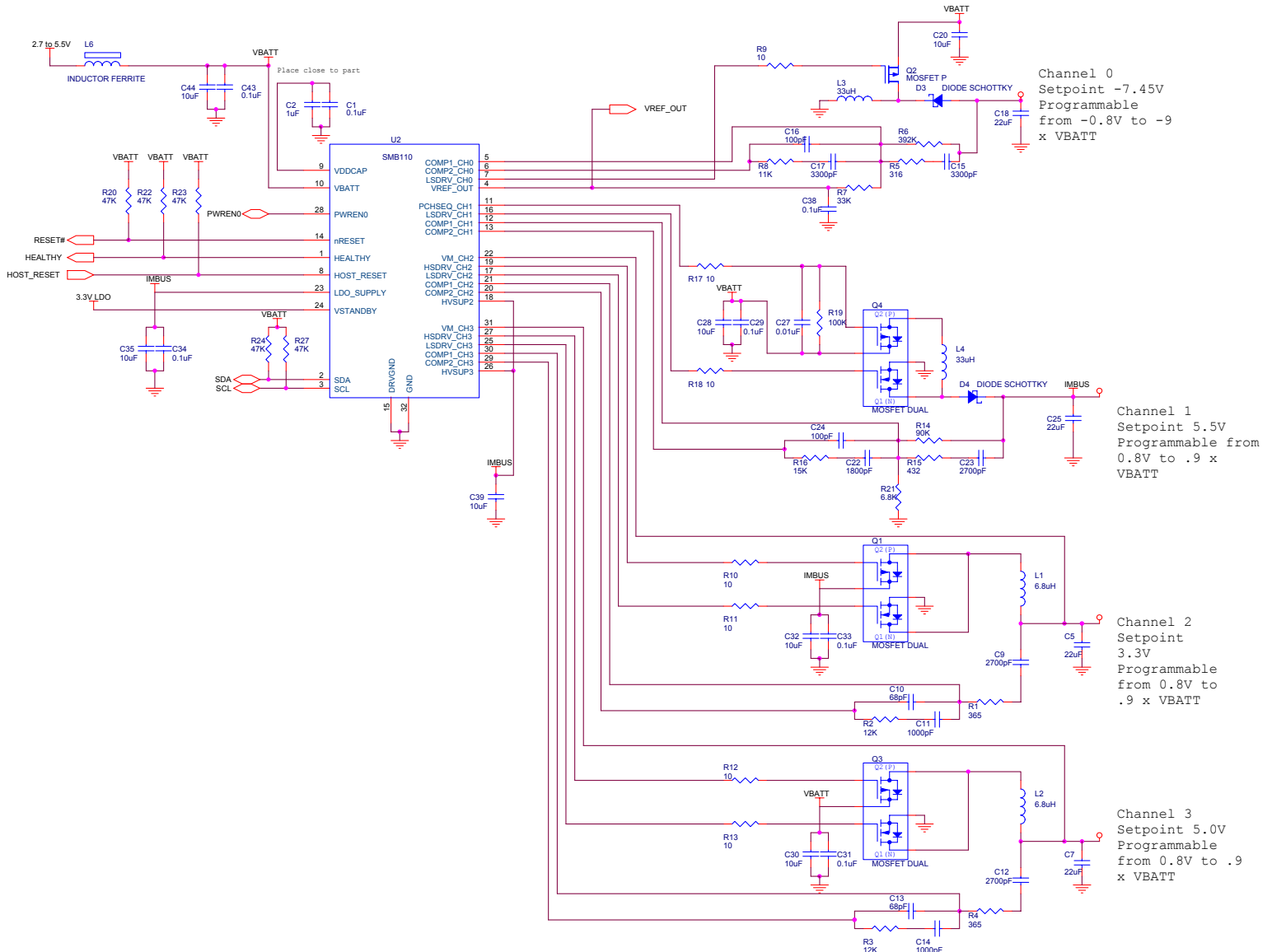

Figure 9 – Applications schematic.



<b>APPLICATIONS INFORMATION (CONTINUED)</b>				
<b>Item</b>	<b>Description-</b>	<b>Vendor / Part Number</b>	<b>Qty</b>	<b>Ref. Des.</b>
<b>Resistors</b>				
1	365Ω, 1/16W, 1%, 0402, SMD	Any	2	R1, R4
2	12KΩ 1/16W, 1%, 0402, SMD	Any	2	R2, R3
3	316KΩ, 1/16W, 1%, 0402, SMD	Any	1	R5
4	392KΩ, 1/16W, 5%, 0402, SMD	Any	1	R6
5	33KΩ, 1/16W, 5%, 0402, SMD	Any	1	R7
6	11KΩ, 1/16W, 5%, 0402, SMD	Any	1	R8
7	10Ω, 1/16W, 5%, 0402, SMD	Any	7	R9, R10, R11, R12, R13, R17, R18
8	90KΩ, 1/16W, 5%, 0402, SMD	Any	1	R14
9	432Ω, 1/16W, 5%, 0402, SMD	Any FDC6432SH	1	R15
10	15KΩ, 1/16W, 5%, 0402, SMD	Any	1	R16
11	100KΩ, 1/16W, 1%, 0402, SMD	Any	1	R19
12	47KΩ, 1/16W, 5%, 0402, SMD	Any	1	R20, R22, R23, R24, R27
13	6.8KΩ, 1/16W, 1%, 0402, SMD	Any	5	R21
<b>Capacitors</b>				
14	0.1uF, 16V, ceramic, X7R, 0402, SMD	Any	7	C1, C29, C31, C33, C34, C38, C43
15	1uF, 16V, ceramic, X7R, 0402, SMD	Any	1	C2
16	22uF, 6.3V, ceramic, Y5V, 1210, SMD	Any	4	C5, C7, C18, C25
17	2700pF, 50V, ceramic, X7R, 0402, SMD	Any	3	C9, C12, C23
18	68pF, 50V, ceramic, X7R, 0402, SMD	Any	2	C10, C13
19	1000pF, 50V, ceramic, X7R, 0402, SMD	Any	2	C11, C14
20	3300pF, 50V, ceramic, COG, 0402, SMD	Any	2	C15, C17
21	100pF, 50V, ceramic, C0G, 0402, SMD	Any	2	C16, C24
22	10uF, 6.3V, ceramic, X5R, 0805, SMD	Any	7	C20, C28, C30, C32, C35, C39, C44
23	1800pF, 50V ceramic, X7R, 0402, SMD	Any	1	C22
24	0.01uF, 50V, ceramic, X7R, 0402, SMD	Any	1	C27
<b>Semiconductors</b>				
25	Diode, Schottky, 20V, 200mA SS-MI	Panasonic, MA2SD24	2	D3, D4
26	MOSFET p-channel, 20V, 0.05 Ohm.	Fairchild, FDC640P	1	Q2
27	MOSFET, Complementary, Fairchild Semiconductor, FDC6420C	Fairchild, FDC6420C or equivalent	3	Q1, Q3, Q4
28	SMB110N	Summit Microelectronics	1	U1

**APPLICATIONS INFORMATION (CONTINUED)**

<b>Item</b>	<b>Description-</b>	<b>Vendor / Part Number</b>	<b>Qty</b>	<b>Ref. Des.</b>
29	Inductor, 33uH, SMD	Coilcraft DO1608C-333 or Asatech 33uH	3	L2, L3, L8
30	Inductor, 6.8uH, SMD	Sumida Corp CR436R8 or Coilcraft DO1608C-682 or Asatech 6.8uH	3	L4, L5, L7



## DEVELOPMENT HARDWARE & SOFTWARE

The end user can obtain the Summit SMX3200 parallel port programming system or the I<sup>2</sup>C2USB (SMX3201) USB programming system for device prototype development. The SMX3200(1) systems consists of a programming Dongle, cable and Windows™ GUI software. It can be ordered on the website or from a local representative. The latest revisions of all software and an application brief describing the SMX3200 and SMX3201 are available from the website (<http://www.summitmicro.com>).

The SMX3200 programming Dongle/cable interfaces directly between a PC's parallel port and the target application; while the SMX3201 interfaces directly to the PC's USB port and the target application. The device is

then configured on-screen via an intuitive graphical user interface employing drop-down menus.

The Windows GUI software will generate the data and send it in I<sup>2</sup>C serial bus format so that it can be directly downloaded to the SMB110 via the programming Dongle and cable. An example of the connection interface is shown in Figure 11.

When design prototyping is complete, the software can generate a HEX data file that should be transmitted to Summit for approval. Summit will then assign a unique customer ID to the HEX code and program production devices before the final electrical test operations. This will ensure proper device operation in the end application.

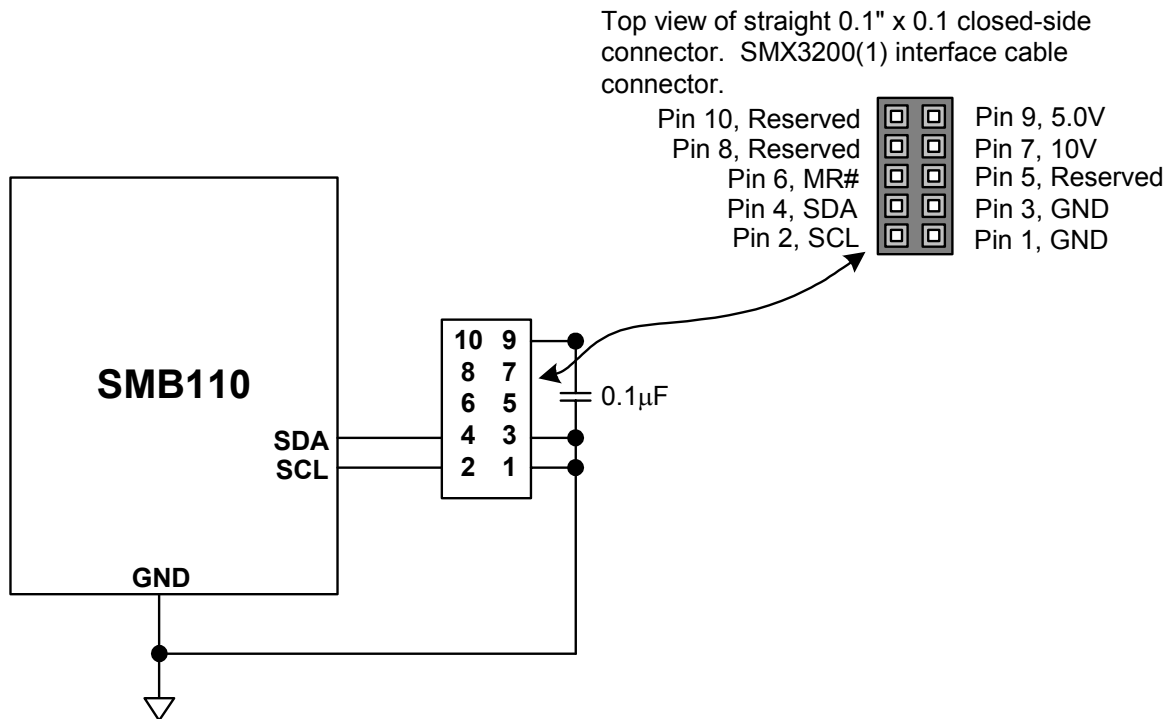

Figure 10 -- SMX3200(1) Programmer I<sup>2</sup>C serial bus connections to program the SMB110.



## I<sup>2</sup>C PROGRAMMING INFORMATION

### SERIAL INTERFACE

Access to the configuration registers, general-purpose memory and command and status registers is carried out over an industry standard 2-wire serial interface (I<sup>2</sup>C). SDA is a bi-directional data line and SCL is a clock input. Data is clocked in on the rising edge of SCL and clocked out on the falling edge of SCL. All data transfers begin with the MSB. During data transfers, SDA must remain stable while SCL is high. Data is transferred in 8-bit packets with an intervening clock period in which an Acknowledge is provided by the device receiving data. The SCL high period ( $t_{HIGH}$ ) is used for generating Start and Stop conditions that precede and end most transactions on the serial bus. A high-to-low transition of SDA while SCL is high is considered a Start condition while a low-to-high transition of SDA while SCL is high is considered a Stop condition.

The interface protocol allows operation of multiple devices and types of devices on a single bus through unique device addressing. The address byte is comprised of a 7-bit device type identifier (slave address). The remaining bit indicates either a read or a write operation. Refer to Table 1 for a description of the address bytes used by the SMB110.

The device type identifier for the memory array, the configuration registers and the command and status registers are accessible with the same slave address. The slave address can be programmed to any seven bit number  $0000000_{BIN}$  through  $1111111_{BIN}$ .

### WRITE

Writing to the memory or a configuration register is illustrated in Figures 11 and 12. A Start condition followed by the slave address byte is provided by the host; the SMB110 responds with an Acknowledge; the host then responds by sending the memory address pointer or configuration register address pointer; the SMB110 responds with an acknowledge; the host then clocks in one byte of data. For memory and configuration register writes, up to 15 additional bytes of data can be clocked in by the host to write to consecutive addresses within the same page.

After the last byte is clocked in and the host receives an Acknowledge, a Stop condition must be issued to initiate the nonvolatile write operation.

### READ

The address pointer for the non-volatile configuration registers and memory registers as well as the volatile command and status registers must be set before data can be read from the SMB110. This is accomplished by issuing a dummy write command, which is a write command that is not followed by a Stop condition. A dummy write command sets the address from which data is read. After the dummy write command is issued, a Start command followed by the address byte is sent from the host. The host then waits for an Acknowledge and then begins clocking data out of the slave device. The first byte read is data from the address pointer set during the dummy write command. Additional bytes can be clocked out of consecutive addresses with the host providing an Acknowledge after each byte. After the data is read from the desired registers, the read operation is terminated by the host holding SDA high during the Acknowledge clock cycle and then issuing a Stop condition. Refer to Figure 13 for an illustration of the read sequence.

### CONFIGURATION REGISTERS

The configuration registers are grouped with the general-purpose memory.

### GENERAL-PURPOSE MEMORY

The 96-byte general-purpose memory block is segmented into two continuous independently lockable blocks. The first 48-byte memory block begins at register address pointer  $A0_{HEX}$  and the second memory block begins at the register address pointer  $C0_{HEX}$ ; see Table 1. Each memory block can be locked individually by writing to a dedicated register in the configuration memory space.

**I<sup>2</sup>C PROGRAMMING INFORMATION (CONTINUED)****GRAPHICAL USER INTERFACE (GUI)**

Device configuration utilizing the Windows based SMB110 graphical user interface (GUI) is highly recommended. The software is available from the Summit website (<http://www.summitmicro.com>). Using the GUI in conjunction with this datasheet, simplifies

the process of device prototyping and the interaction of the various functional blocks. A programming Dongle (SMX3200) is available from Summit to communicate with the SMB110. The Dongle connects directly to the parallel port of a PC and programs the device through a cable using the I<sup>2</sup>C bus protocol. See figure 7 and the SMX3200 Data Sheet.

Slave Address	Register Type
0000000 <sub>BIN</sub> to 1111111 <sub>BIN</sub>	Configuration Registers are located in 00 <sub>HEX</sub> thru 9F <sub>HEX</sub>
	General-Purpose Memory Block 0 is located in A0 <sub>HEX</sub> thru BF <sub>HEX</sub>
	General-Purpose Memory Block 1 is located in C0 <sub>HEX</sub> thru FF <sub>HEX</sub>

**Table 1 – Possible address bytes used by the SMB110.**



I<sup>2</sup>C PROGRAMMING INFORMATION (CONTINUED)

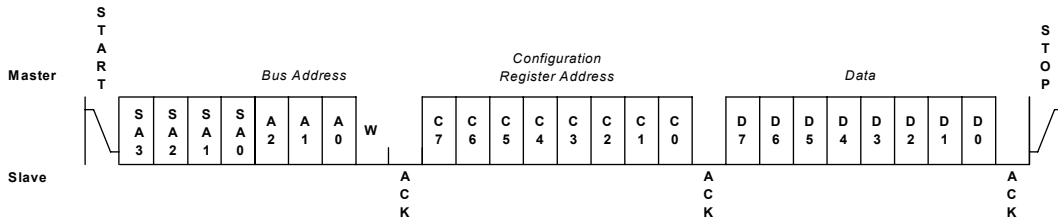

Figure 11 –Register Byte Write

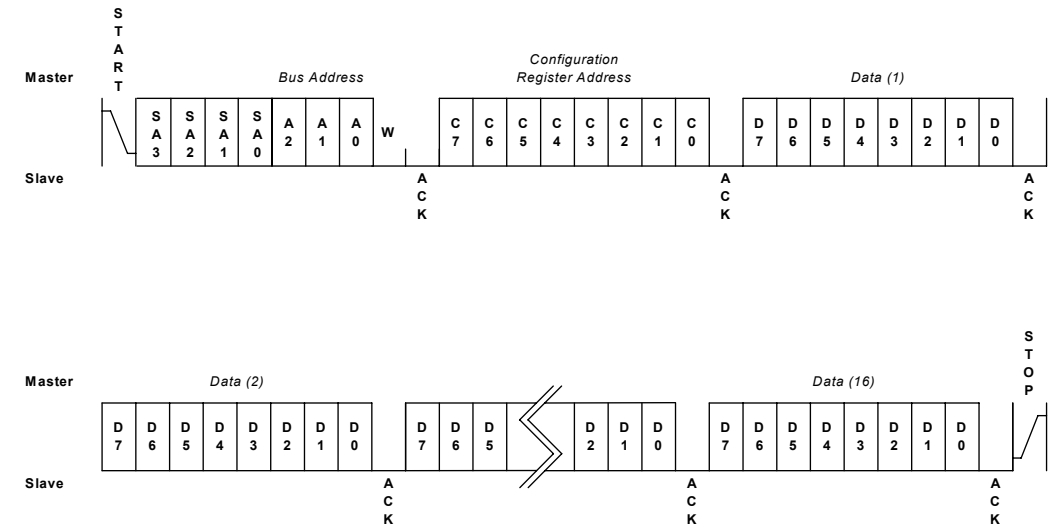

Figure 12 –Register Page Write

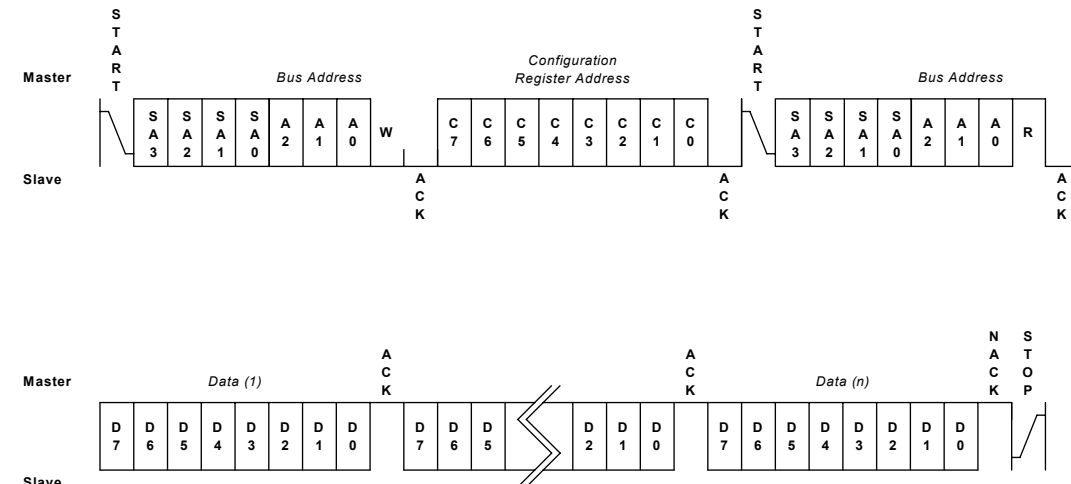

Figure 13 -Register Read

**DEFAULT CONFIGURATION REGISTER SETTINGS – SMB110NC-323L**

Register	Contents	Register	Contents	Register	Contents
R0	D7	R15	00	R2C	02
R3	60	R16	20	R2D	00
R4	7D	R17	00	R2E	39
R5	A5	R18	02	R2F	2E
R8	30	R1B	02	R50	CF
RB	60	R1C	02	R53	5B
RC	50	R1D	02	R54	71
RD	40	R20	30	R57	95
R10	96	R23	30	R58	DF
R11	5A	R24	30	R5B	65
R12	14	R27	30	R5C	8A
R13	50	R2A	03	R5D	B6
R14	A0	R2B	00		

The default device ordering number is SMB110NC-323L. It is programmed with the register contents as shown above and tested over the commercial temperature range. The ordering number is derived from the customer supplied hex file. New device suffix numbers are assigned to non-default requirements.





**PACKAGE**

QFN 32 pads  
0.5mm Pitch

REFERENCE JEDEC MO-220

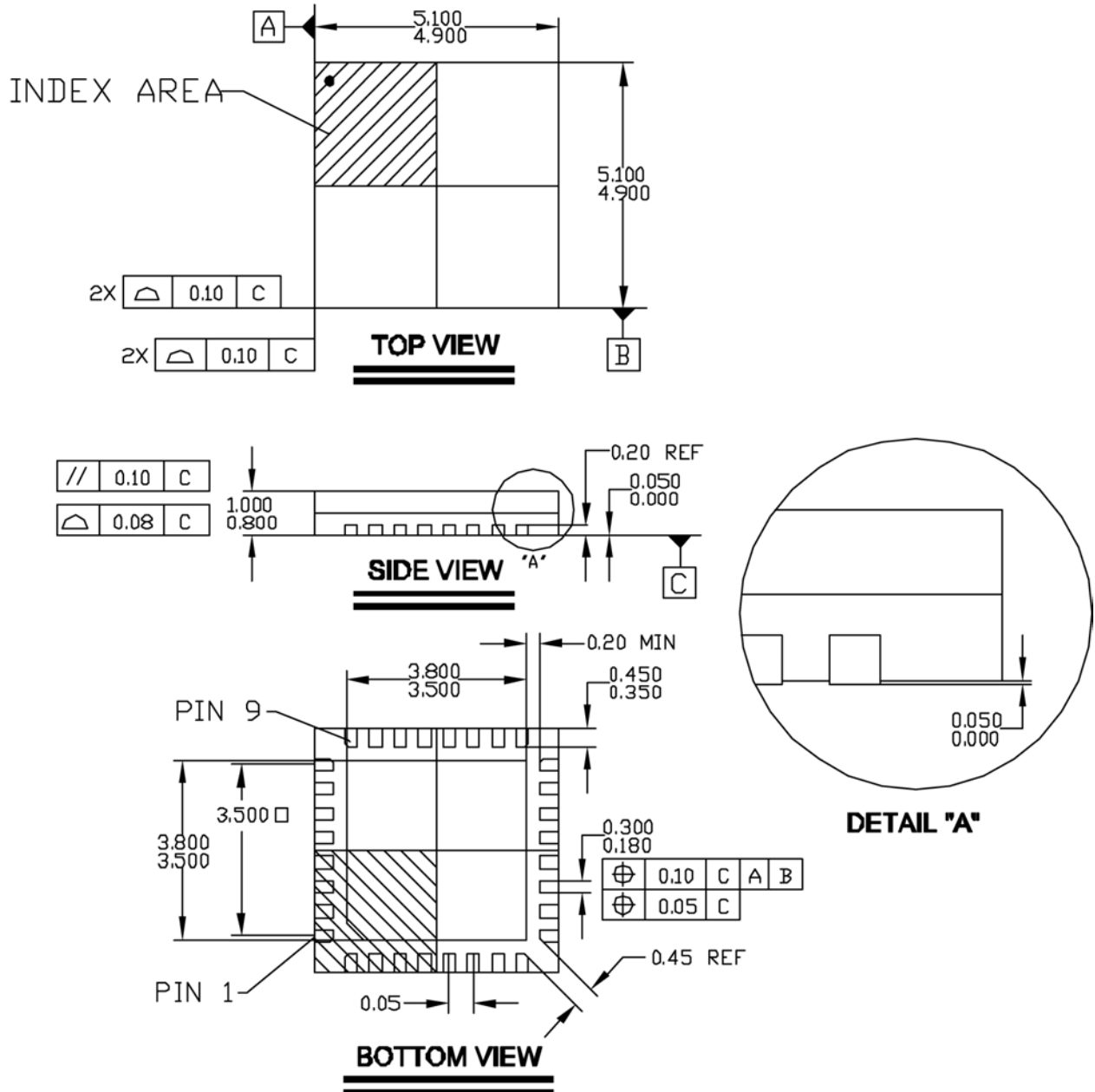

1. NOTES: ALL DIMENSIONS ARE mm [MAX] [MIN]



## PART MARKING

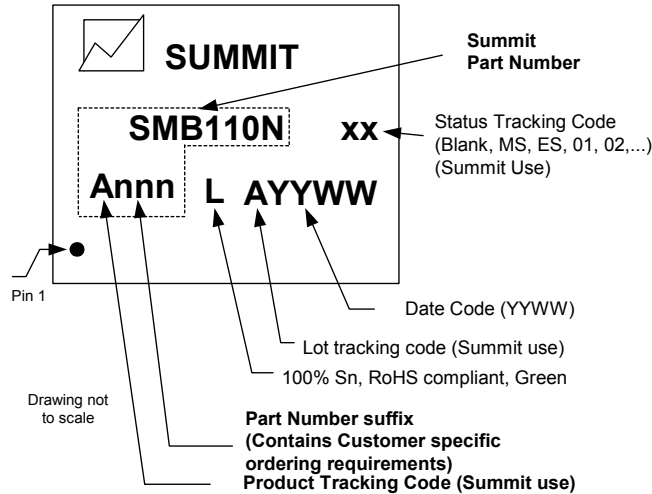

## ORDERING INFORMATION

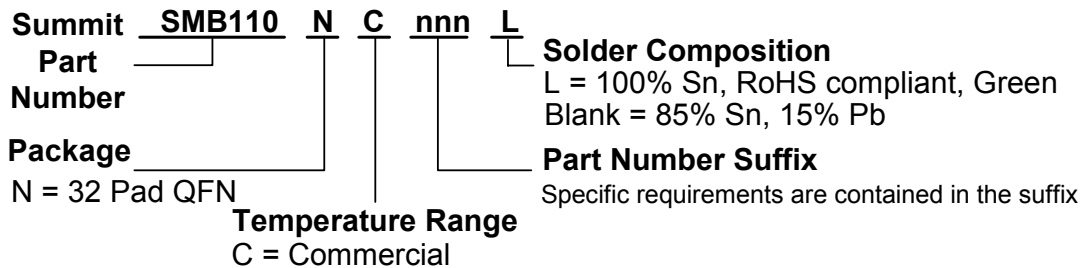

## NOTICE

NOTE 1 - This is a **Preliminary Information** data sheet that describes a Summit product currently in pre-production with limited characterization.

SUMMIT Microelectronics, Inc. reserves the right to make changes to the products contained in this publication in order to improve design, performance or reliability. SUMMIT Microelectronics, Inc. assumes no responsibility for the use of any circuits described herein, conveys no license under any patent or other right, and makes no representation that the circuits are free of patent infringement. Charts and schedules contained herein reflect representative operating parameters, and may vary depending upon a user's specific application. While the information in this publication has been carefully checked, SUMMIT Microelectronics, Inc. shall not be liable for any damages arising as a result of any error or omission.

SUMMIT Microelectronics, Inc. does not recommend the use of any of its products in life support or aviation applications where the failure or malfunction of the product can reasonably be expected to cause any failure of either system or to significantly affect their safety or effectiveness. Products are not authorized for use in such applications unless SUMMIT Microelectronics, Inc. receives written assurances, to its satisfaction, that: (a) the risk of injury or damage has been minimized; (b) the user assumes all such risks; and (c) potential liability of SUMMIT Microelectronics, Inc. is adequately protected under the circumstances.

Revision 2.2 - This document supersedes all previous versions. Please check the Summit Microelectronics Inc. web site at <http://www.summitmicro.com> for data sheet updates.

© Copyright 2005 SUMMIT MICROELECTRONICS, Inc. **PROGRAMMABLE ANALOG FOR A DIGITAL WORLD™**

ADOC™ is a registered trademarks of Summit Microelectronics Inc., I<sup>2</sup>C is a trademark of Philips Corporation.