

## Single Channel Silicon ESD Protector Overvoltage Protection Device

DOCUMENT: SCD28186  
REV LETTER: B  
REV DATE: FEBRUARY 6, 2012  
PAGE NO.: PAGE 1 of 6

### Specification Status: RELEASED

#### BENEFITS

- Industry-leading lowest capacitance; provides lowest insertion loss for high speed data signals
- Small size ESD protection diodes for high speed data signals (0402 size devices)
- Helps protect electronic circuits against damage from Electrostatic Discharge (ESD), surge and cable discharge events
- Assists equipment to pass IEC61000-4-2, level 4 testing

#### FEATURES

- Low capacitance: 0.20 pF (200fF) (typ)
- Low leakage current : 25nA @ 5V (typ)
- Low clamping voltage: +9.20 / -0.80V (typ) @ (tp=8x20µs, Ipp=2A)
- ESD maximum rating per IEC61000-4-2 standard:
  - 20kV contact discharge
  - 20kV air discharge
- Surge: 2A (max) @ (tp=8x20µs) per IEC61000-4-5
- Small size and low profile: XDFN packages

#### APPLICATIONS

- Consumer, mobile and portable electronics
- Tablet PC and external storage with high speed interfaces
- Ultra-high speed data lines
- USB 3.0/2.0, HDMI 1.3/1.4, DisplayPort, Thunderbolt (Light Peak), V-by-One HS, and LVDS interfaces
- Applications requiring high ESD performance in small packages

#### MATERIALS INFORMATION

RoHS Compliant    ELV Compliant    Halogen Free \*    Lead Free

Directive 2000/53/EC  
Compliant

Directive 2002/95/EC  
Compliant



\* Halogen Free refers to: Br≤900ppm, Cl≤900ppm, Br+Cl≤1500ppm  
SESD devices meet MSL-1 Requirements  
DFN case epoxy meets UL 94 V-0



#### PART NUMBERING

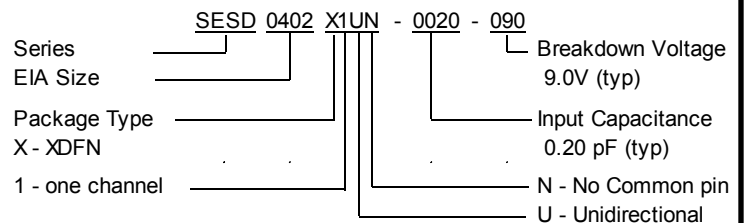

#### SCHEMATIC AND PIN CONFIGURATION

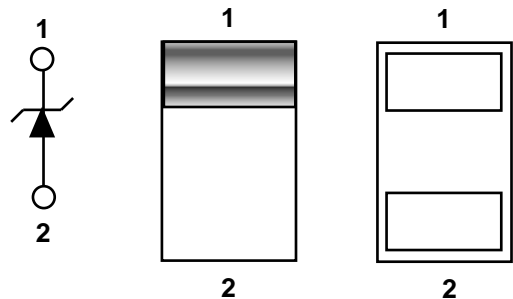

Top View

Bottom View

# Single Channel Silicon ESD Protector Overvoltage Protection Device

DOCUMENT: SCD28186  
 REV LETTER: B  
 REV DATE: FEBRUARY 6, 2012  
 PAGE NO.: PAGE 2 of 6

308 Constitution Drive  
 Menlo Park, CA 94025-1164  
 www.circuitprotection.com

## DEVICE MAXIMUM RATING

ESD Withstand <sup>(1)</sup> (IEC 61000-4-2, level 4)		Temperature		Peak Current (tp=8x20µs)
Contact (kV)	Air (kV)	Operating (°C)	Storage (°C)	I <sub>pp</sub> (A)
20	20	-55 to +125	-55 to +150	2.0

<sup>(1)</sup> 20kV @ 1 pulse; 10kV @ 100 pulses; 8kV @ 1,000 pulses (under IEC6100-4-2)

- Device maximum rating @ T = 25°C, unless otherwise specified
- Caution: Stress exceeding Device Maximum Ratings may damage the device  
 Prolonged exposure to stresses above the recommended operating conditions may affect device reliability

## DEVICE ELECTRICAL CHARACTERISTICS

Input Capacitance @ V <sub>R</sub> = 0V, f = 3GHz, I/O to GND (pF)		Breakdown Voltage V <sub>BR</sub> @ I <sub>T</sub> =1mA (V)	Reverse Working Voltage (V)		Reverse Leakage Current I <sub>L</sub> @ V <sub>RWM</sub> =5.0V (nA)		Clamping Voltage V <sub>CL</sub> @ I <sub>pp</sub> =2.0A (V)
Typ	Maximum	Typ	Min	Max	Typ	Max	Typ
0.20	0.22	+9.00 / -0.80	0	+8.00	25.0	50.0	+9.20 / -0.80

- All device electrical characteristics @ T = 25°C, unless otherwise specified

## FIGURE 1. INSERTION LOSS DIAGRAM

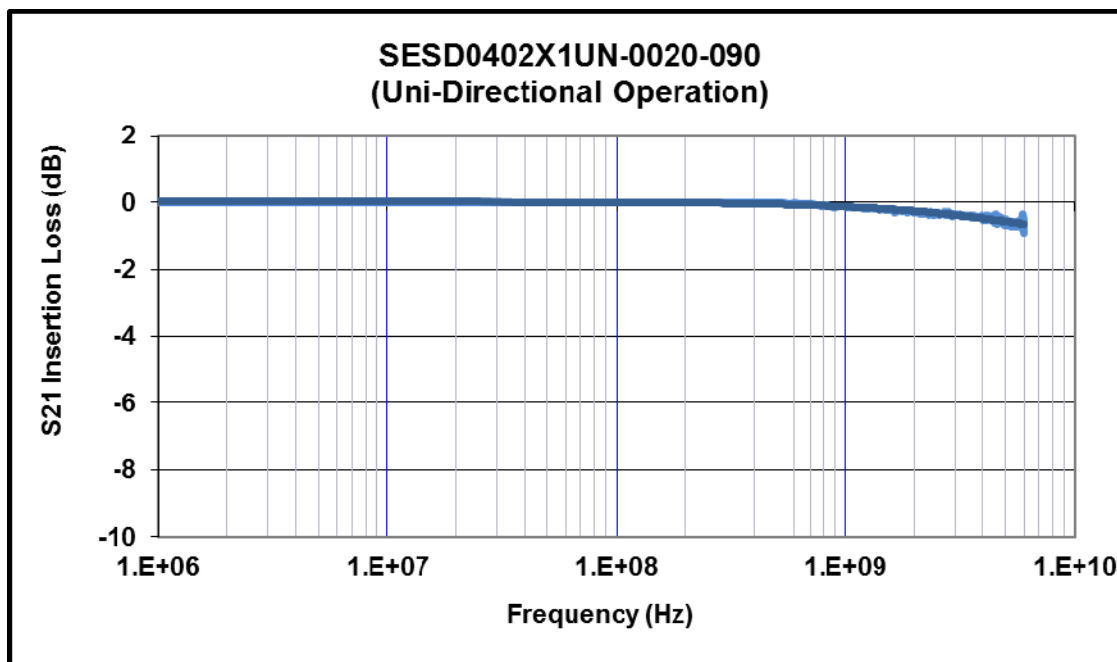

Application	Bit Rate (Gbps)	@Freq (GHz)	Ins. Loss (dB)
HDMI 1.4 (1080P)	2.25	1.13	-0.15
DisplayPort	2.70	1.35	-0.20
HDMI 1.4 (4K / QuadHD)*	3.40	1.70	-0.23
USB3.0	5.00	2.50	-0.29
eSATA	6.00	3.00	-0.35
Thunderbolt	10.0	5.00	-0.50

\*HDMI 4K / QuadHD resolutions (4096 x 2160) ready

# Single Channel Silicon ESD Protector Overvoltage Protection Device

DOCUMENT: SCD28186  
REV LETTER: B  
REV DATE: FEBRUARY 6, 2012  
PAGE NO.: PAGE 3 of 6

**FIGURE 2. DEVICE IV CURVE**

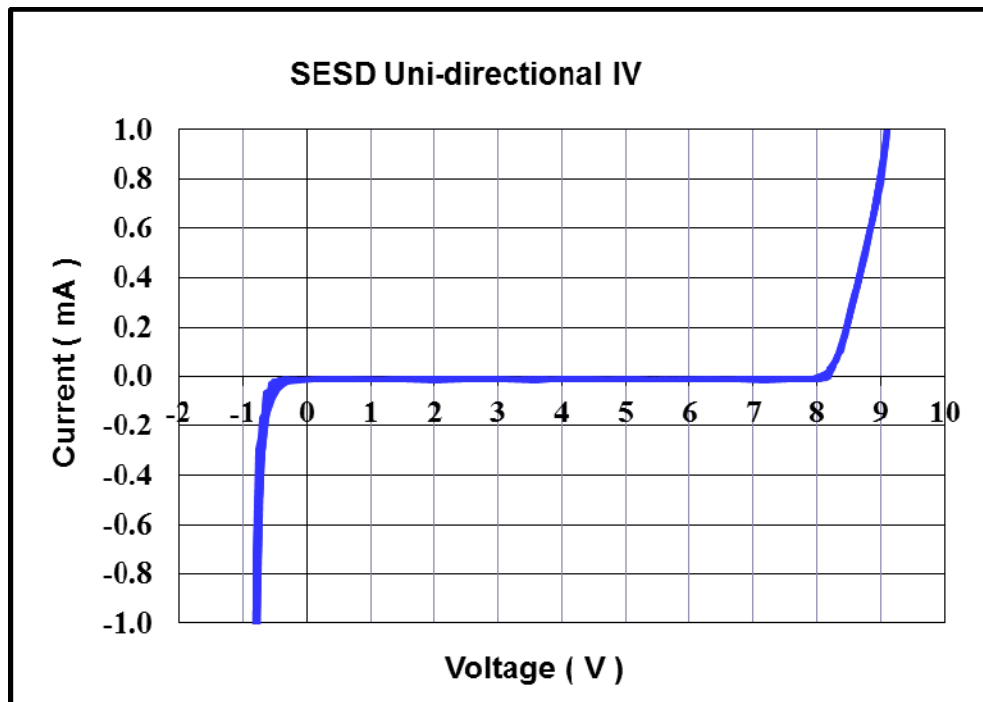

## DEVICE DIMENSIONS

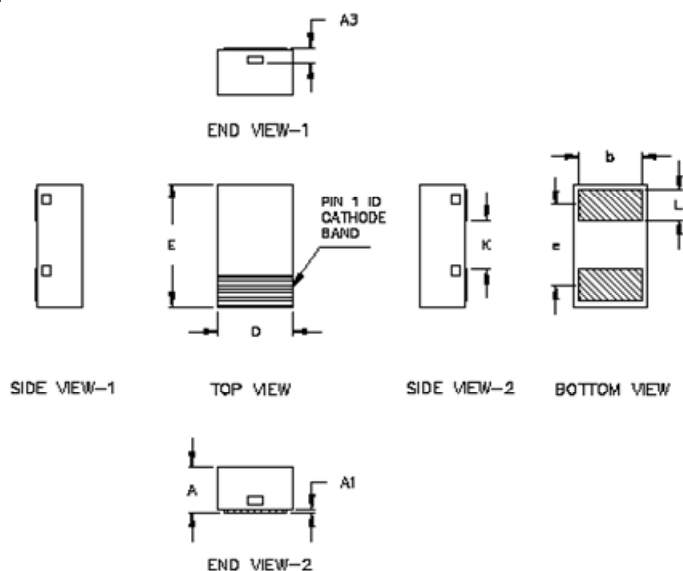

Dim	SESD0402 XDFN					
	Millimeters (mm)			Inches (in)		
	Min	Nom	Max	Min	Nom	Max
A	0.33	0.38	0.43	0.013	0.015	0.017
A1	0	-	0.05	0	-	0.002
A3	0.13 ref.			0.005 ref.		
D	0.55	0.60	0.65	0.022	0.024	0.026
E	0.95	1.00	1.05	0.037	0.039	0.041
K	0.35	0.40	0.45	0.014	0.016	0.018
b	0.45	0.50	0.55	0.018	0.020	0.022
L	0.20	0.25	0.30	0.008	0.010	0.012
e	0.65 BSC			0.026 BSC		

BSC – Basic Spacing between Centers

**Single Channel  
Silicon ESD Protector  
Overvoltage Protection Device**

DOCUMENT: SCD28186  
REV LETTER: B  
REV DATE: FEBRUARY 6, 2012  
PAGE NO.: PAGE 4 of 6

308 Constitution Drive  
Menlo Park, CA 94025-1164  
www.circuitprotection.com

**RECOMMENDED LANDING PATTERN:**

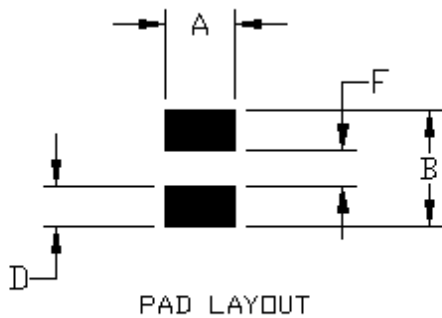

SESD Landing Pad Layout 0402 Package		
Symbol	Milimeters (mm)	Inches (in)
A	0.60	0.024
B	1.00	0.039
D	0.35	0.014
F	0.30	0.012

**PACKAGING**

Packaging	Tape & Reel	Standard Box
SESD0402X1UN-0020-090	10,000	50,000

**REEL DIMENSIONS**

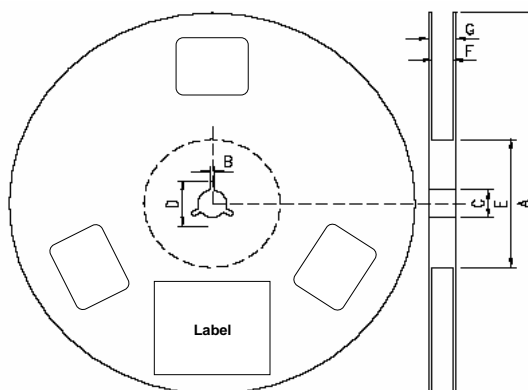

Dimensions	A	B	C	D	E	F	G
(mm)	180.0 ± 1.5	2.3. 0 ± 0.2	13.0 + 0.5 / -0.2	17.3 ± 0.2	60.5 ± 1.5	8.4 +1.5/-0.0	14.4 (max)

**Single Channel  
Silicon ESD Protector  
Overvoltage Protection Device**

DOCUMENT: SCD28186  
REV LETTER: B  
REV DATE: FEBRUARY 6, 2012  
PAGE NO.: PAGE 5 of 6

308 Constitution Drive  
Menlo Park, CA 94025-1164  
www.circuitprotection.com

**CARRIER TAPE DIMENSIONS**

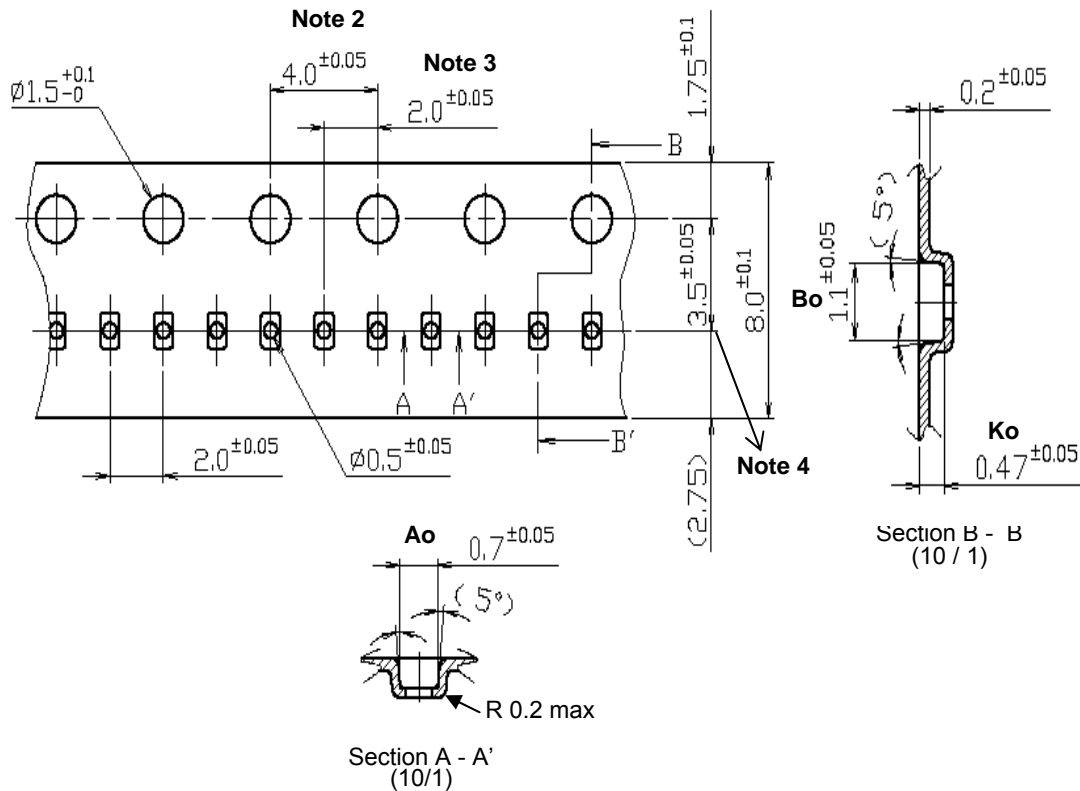

Ao	0.07 ± 0.05
Bo	1.1 ± 0.05
Ko	0.47 ± 0.05

Note 1. All dimensions in mm  
Note 2. Cumulative tolerance is 200 ± 0.3 / 50MM pitch  
Note 3. Center point of hole tolerance is 2.0 ± 0.5  
Note 4. Center point of hole tolerance is 3.5 ± 0.5

**Single Channel  
Silicon ESD Protector  
Overvoltage Protection Device**

DOCUMENT: SCD28186  
REV LETTER: B  
REV DATE: FEBRUARY 6, 2012  
PAGE NO.: PAGE 6 of 6

308 Constitution Drive  
Menlo Park, CA 94025-1164  
www.circuitprotection.com

**SOLDER REFLOW RECOMMENDATION**

A	Temperature ramp up 1	From ambient to Preheating temperature	30s to 60s
B	Preheating	140°C - 160°C	60s to 120s
C	Temperature ramp up 2	From Preheating to Main heating temperature	20s to 40s
D	Main heating	at 200°C at 220°C at 240°C at 260°C	60s ~ 70s 50s ~ 60s 30s ~ 40s 5s ~ 10s
E	Cooling	From main heating temperature to 100°C	4°C/s (max)

**FIGURE 3. REFLOW PROFILE**

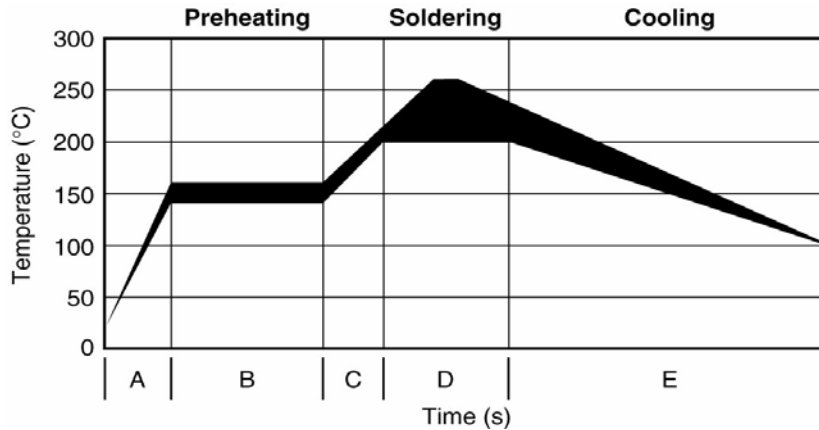

All information, including illustrations, is believed to be accurate and reliable. Users, however, should independently evaluate the suitability of and test each product selected for their application. Tyco Electronics Corporation and/or its Affiliates in the TE Connectivity Ltd. family of companies ("TE") makes no warranties as to the accuracy or completeness of the information, and disclaims any liability regarding its use. TE's only obligations are those in the TE Standard Terms and Conditions of Sale and in no case will TE be liable for any incidental, indirect, or consequential damages arising from the sale, resale, use, or misuse of its products. Specifications are subject to change without notice. In addition, TE reserves the right to make changes to materials or processing that do not affect compliance with any applicable specification without notification to Buyer. Without expressed written consent by an officer of TE, TE does not authorize the use of any of its products as components in nuclear facility applications, aerospace, or in critical life support devices or systems.

**TE Connectivity, TE Connectivity (logo), and TE (logo)** are trademarks.

Other logos, products and /or company names might be trademarks of their respective owners.