

## 32-bit ARM™ Cortex™-M3 based Microcontroller

# FM3 MB9A110 Series

**MB9AF111L/M/N, MB9AF112L/M/N, MB9AF114L/M/N,  
MB9AF115M/N, MB9AF116M/N**

### ■ DESCRIPTION

The MB9A110 Series are a highly integrated 32-bit microcontroller that target for high-performance and cost-sensitive embedded control applications.

The MB9A110 Series are based on the ARM Cortex-M3 Processor and on-chip Flash memory and SRAM, and peripheral functions, including Motor Control Timers, ADCs and Communication Interfaces (UART, CSIO, I<sup>2</sup>C, LIN).

The products which are described in this data sheet are placed into TYPE1 product categories in "FM3 MB9Axxx/MB9Bxxx Series PERIPHERAL MANUAL".

Note: ARM and Cortex are the trademarks of ARM Limited in the EU and other countries.

**ARM™**

## ■ FEATURES

### ● 32-bit ARM Cortex-M3 Core

- Processor version: r2p1
- Up to 40MHz Frequency Operation
- Integrated Nested Vectored Interrupt Controller (NVIC): 1 NMI (non-maskable interrupt) and 48 peripheral interrupts and 16 priority levels
- 24-bit System timer (Sys Tick): System timer for OS task management

### ● On-chip Memories

#### [Flash memory]

- Up to 512 Kbyte
- Read cycle: 0wait-cycle
- Security function for code protection

#### [SRAM]

This Series contain a total of up to 32Kbyte on-chip SRAM memories. This is composed of two independent SRAM (SRAM0, SRAM1). SRAM0 is connected to I-code bus or D-code bus of Cortex-M3 core. SRAM1 is connected to System bus.

- SRAM0: Up to 16 Kbyte.
- SRAM1: Up to 16 Kbyte.

### ● External Bus Interface\*

- Supports SRAM, NOR Flash device
  - Up to 8 chip selects
  - 8/16-bit Data width
  - Up to 25-bit Address bit
  - Supports Address/Data multiplex
  - Supports external RDY input.
- \* : MB9AF111L, F112L, F114L do not support External Bus Interface

## ● Multi-function Serial Interface (Max 8channels)

- 4 channels with 16-byte FIFO (ch.4-ch.7), 4 channels without FIFO (ch.0-ch.3)
- Operation mode is selectable from the followings for each channel.
  - UART
  - CSIO
  - LIN
  - I<sup>2</sup>C

### [UART]

- Full-duplex double buffer
- Selection with or without parity supported
- Built-in dedicated baud rate generator
- External clock available as a serial clock
- Hardware Flow control : Automatically control the transmission by CTS/RTS (only ch.4)\*
- Various error detect functions available (parity errors, framing errors, and overrun errors)  
\* : MB9AF111L, F112L, F114L do not support Hardware Flow control

### [CSIO]

- Full-duplex double buffer
- Built-in dedicated baud rate generator
- Overrun error detect function available

### [LIN]

- LIN protocol Rev.2.1 supported
- Full-duplex double buffer
- Master/Slave mode supported
- LIN break field generate (can be changed 13-16bit length)
- LIN break delimiter generate (can be changed 1-4bit length)
- Various error detect functions available (parity errors, framing errors, and overrun errors)

### [I<sup>2</sup>C]

Standard mode (Max 100kbps) / High-speed mode (Max 400Kbps) supported

## ● DMA Controller (8channels)

DMA Controller has an independent bus for CPU, so CPU and DMA Controller can process simultaneously.

- 8 independently configured and operated channels
- Transfer can be started by software or request from the built-in peripherals
- Transfer address area: 32bit (4Gbyte)
- Transfer mode: Block transfer/Burst transfer/Demand transfer
- Transfer data type: byte/half-word/word
- Transfer block count: 1 to 16
- Number of transfers: 1 to 65536

## ● A/D Converter (Max 16channels)

### [12-bit A/D Converter]

- Successive Approximation Register type
- Built-in 3unit\*
- Conversion time: 1.0μs@5V
- Priority conversion available (priority at 2levels)
- Scanning conversion mode
- Built-in FIFO for conversion data storage (for SCAN conversion: 16steps, for Priority conversion: 4steps)  
\* : MB9AF111L, F112L, F114L built-in 2unit

## ● Base Timer (Max 8channels)

Operation mode is selectable from the followings for each channel.

- 16-bit PWM timer
- 16-bit PPG timer
- 16/32-bit reload timer
- 16/32-bit PWC timer

## ● General Purpose I/O Port

This series can use its pins as I/O ports when they are not used for external bus or peripherals. Moreover, the port relocate function is built in. It can set which I/O port the peripheral function can be allocated.

- Capable of pull-up control per pin
- Capable of reading pin level directly
- Built-in the port relocate function
- Up to 83 fast I/O Ports@100pin Package
- Some pins are 5V tolerant I/O (MB9AF115M/N, MB9AF116M/N only)  
Please see "■ PIN DESCRIPTION" to confirm the corresponding pins.

## ● Multi-function Timer (Max 2unit)

The Multi-function timer is composed of the following blocks.

- 16-bit free-run timer × 3ch/unit
- Input capture × 4ch/unit
- Output compare × 6ch/unit
- A/D activating compare × 3ch/unit
- Waveform generator × 3ch/unit
- 16-bit PPG timer × 3ch/unit

The following function can be used to achieve the motor control.

- PWM signal output function
- DC chopper waveform output function
- Dead time function
- Input capture function
- A/D convertor activate function
- DTIF (Motor emergency stop) interrupt function

## ● Quadrature Position/Revolution Counter (QPRC) (Max 2unit)

The Quadrature Position/Revolution Counter (QPRC) is used to measure the position of the position encoder. Moreover, it is possible to use up/down counter.

- The detection edge of the three external event input pins AIN, BIN and ZIN is configurable.
- 16-bit position counter
- 16-bit revolution counter
- Two 16-bit compare registers

## ● Dual Timer (Two 32/16bit Down Counter)

The Dual Timer consists of two programmable 32/16-bit down counters. Operation mode is selectable from the followings for each channel.

- Free-running
- Periodic (=Reload)
- One-shot

## ● Watch Counter

The Watch counter is used for wake up from power saving mode.

- Interval timer: up to 64s (Max)@ Sub Clock : 32.768kHz

## ● External Interrupt Controller Unit

- Up to 16 external vectors
- Include one non-maskable interrupt (NMI)

## ● Watch dog Timer (2channels)

A watchdog timer can generate interrupts or a reset when a time-out value is reached.

This series consists of two different watchdogs, a "Hardware" watchdog and a "Software" watchdog.

"Hardware" watchdog timer is clocked by low speed CR oscillator. Therefore, "Hardware" watchdog is active in any power saving mode except STOP.

## ● CRC (Cyclic Redundancy Check) Accelerator

The CRC accelerator helps a verify data transmission or storage integrity.

CCITT CRC16 and IEEE-802.3 CRC32 are supported.

- CCITT CRC16 Generator Polynomial: 0x1021
- IEEE-802.3 CRC32 Generator Polynomial: 0x04C11DB7

## ● Clock and Reset

### [Clocks]

Five clock sources (2 ext. osc, 2 CR osc, and main PLL) that are dynamically selectable.

- Main Clock : 4MHz to 48MHz
- Sub Clock : 32.768kHz
- High-speed CR Clock : 4MHz
- Low-speed CR Clock : 100kHz
- Main PLL Clock

### [Resets]

Reset requests from INITX pins, Power on reset, Software reset, watchdog timers reset, low voltage detector reset and clock supervisor reset.

## ● Clock Super Visor (CSV)

Clocks generated by CR oscillators are used to supervise abnormality of the external clocks.

- External OSC clock failure (clock stop) is detected, reset is asserted.
- External OSC frequency anomaly is detected, interrupt or reset is asserted.

## ● Low Voltage Detector (LVD)

This Series include 2-stage monitoring of voltage on the VCC. When the voltage falls below the voltage has been set, Low Voltage Detector generates an interrupt or reset.

- LVD1: error reporting via interrupt
- LVD2: auto-reset operation

# MB9A110 Series

## ● Low Power Mode

Three power saving modes supported.

- SLEEP
- TIMER
- STOP

## ● Debug

- Serial Wire JTAG Debug Port (SWJ-DP)
- Embedded Trace Macrocells (ETM) provide comprehensive debug and trace facilities.\*
- Trace Port Interface Unit (TPIU) for bridging to a Trace Port Analyzer.\*

\* : MB9AF111L/M, F112L/M, F114L/M, F115M, F116M support only SWJ-DP.

## ● Power Supply

- VCC = 2.7V to 5.5V: Correspond to the wide range voltage.

# MB9A110 Series

## ■ PRODUCT LINEUP

### ● Memory size

Product device	MB9AF111L/M/N	MB9AF112L/M/N	MB9AF114L/M/N
On-chip Flash	64Kbyte	128Kbyte	256Kbyte
On-chip SRAM	16Kbyte	16Kbyte	32Kbyte

Product device	MB9AF115M/N	MB9AF116M/N
On-chip Flash	384Kbyte	512Kbyte
On-chip SRAM	32Kbyte	32Kbyte

### ● Function

Product device		MB9AF111L MB9AF112L MB9AF114L	MB9AF111M MB9AF112M MB9AF114M MB9AF115M MB9AF116M	MB9AF111N MB9AF112N MB9AF114N MB9AF115N MB9AF116N
Pin count		64	80	100
CPU		Cortex-M3		
Freq.		40MHz		
Power supply voltage range		2.7V to 5.5V		
DMAC		8ch		
External Bus Interface		-	Addr:21bit (Max) Data:8 bit CS:4 (Max) Support: SRAM, NOR Flash	Addr:25bit (Max) Data:8/16 bit CS:8 (Max) Support: SRAM, NOR Flash
MF Serial Interface (UART/CSIO/LIN/I <sup>2</sup> C)		8ch (Max)		
Base Timer (PWC/Reload timer/PWM/PPG)		8ch (Max)		
MF-Timer	A/D activation compare	3ch	1 unit	2 units (Max)
	Input capture	4ch		
	Free-run timer	3ch		
	Output compare	6ch		
	Waveform generator	3ch		
	PPG	3ch		
QPRC		2ch (Max)		
Dual Timer		1 unit		
Watch Counter		1 unit		
CRC Accelerator		Yes		
Watchdog timer		1ch (SW) + 1ch (HW)		
External Interrupts		7pins (Max) + NMI × 1	11pins (Max) + NMI × 1	16pins (Max) + NMI × 1
I/O ports		51pins (Max)	66pins (Max)	83pins (Max)
12 bit A/D converter		9ch (2 units)	12ch (3 units)	16ch (3 units)
CSV (Clock Super Visor)		Yes		
LVD (Low Voltage Detector)		2ch		
Internal OSC	High-speed	4MHz (± 2%)		
	Low-speed	100kHz (Typ)		
Debug Function		SWJ-DP		SWJ-DP/TPIU/ETM

# MB9A110 Series

Note: All signals of the peripheral function in each product cannot be allocated by limiting the pins of package.  
It is necessary to use the port relocate function of the General I/O port according to your function use.



# MB9A110 Series

## ■ PACKAGES

Package	Product name	MB9AF111L MB9AF112L MB9AF114L	MB9AF111M MB9AF112M MB9AF114M MB9AF115M MB9AF116M	MB9AF111N MB9AF112N MB9AF114N MB9AF115N MB9AF116N
	LQFP: FPT-64P-M24/M38 (0.5mm pitch)		○	-
LQFP: FPT-64P-M23/M39 (0.65mm pitch)		○	-	-
LQFP: FPT-80P-M21/M37 (0.5mm pitch)		-	○	-
LQFP: FPT-100P-M20/M23 (0.5mm pitch)		-	-	○
QFP: FPT-100P-M06 (0.65mm pitch)		-	-	○
BGA: BGA-112P-M04 (0.8mm pitch)		-	-	○*

○ : Supported

\* : MB9AF115N, MB9AF116N is planning

Note : Refer to "■PACKAGE DIMENSIONS" for detailed information on each package.

# MB9A110 Series

## ■ PIN ASSIGNMENT

### ● FPT-100P-M20/M23

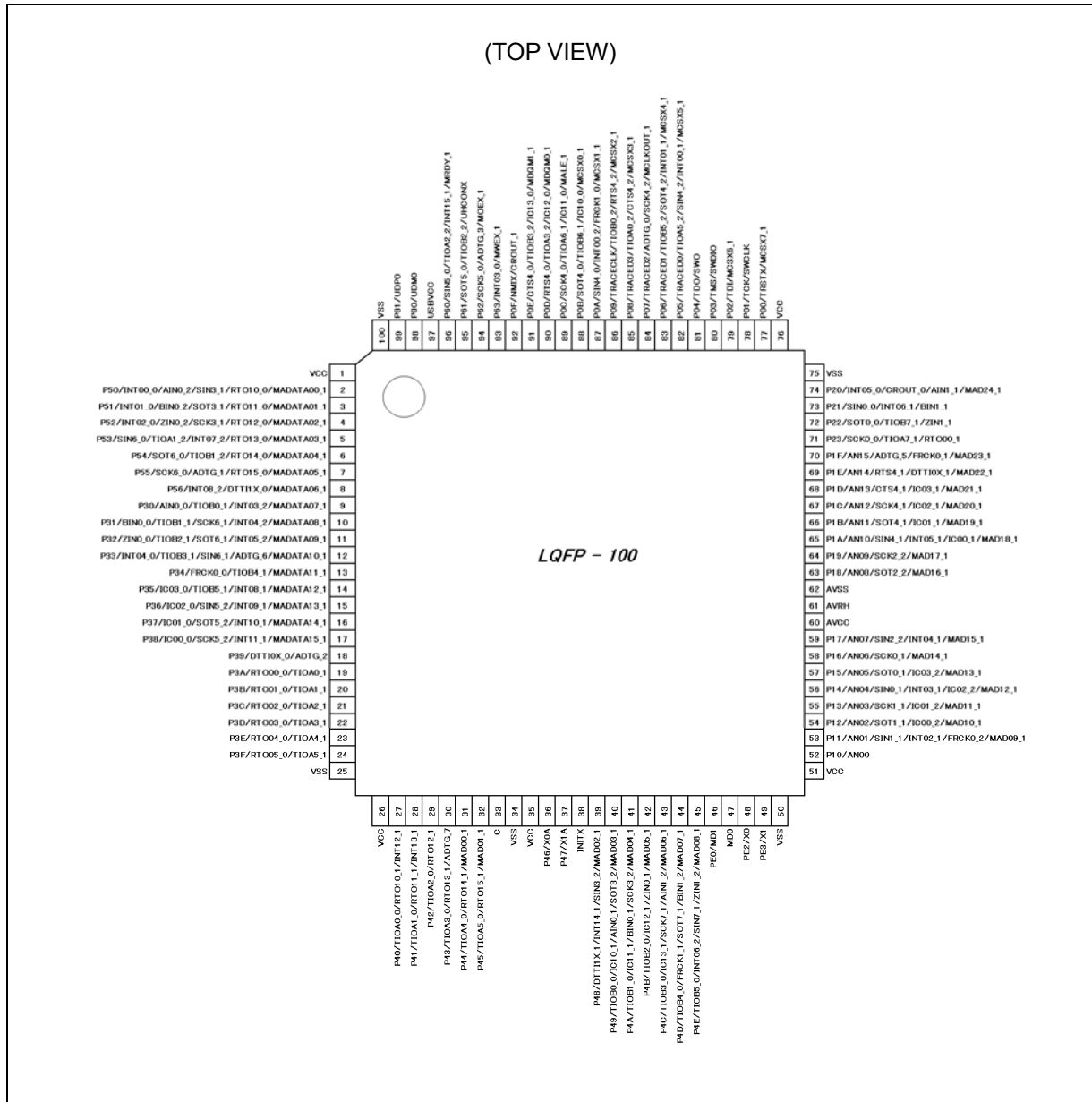

### <Note>

The number after the underscore ("\_") in pin names such as XXX\_1 and XXX\_2 indicates the relocated port number. For these pins, there are multiple pins that provide the same function for the same channel. Use the extended port function register (EPFR) to select the pin.

## ● FPT-100P-M06

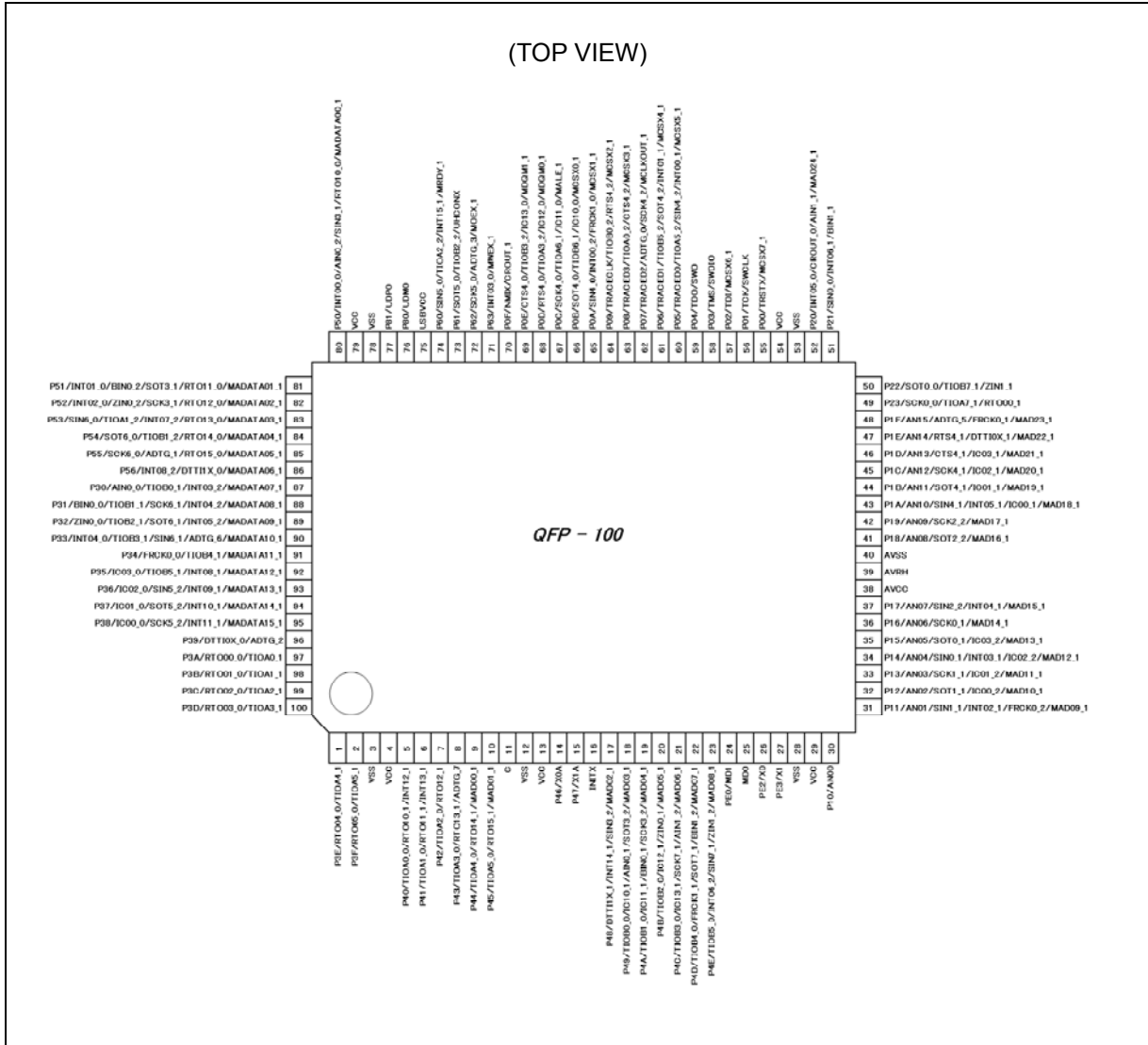

### <Note>

The number after the underscore ("\_") in pin names such as XXX\_1 and XXX\_2 indicates the relocated port number. For these pins, there are multiple pins that provide the same function for the same channel. Use the extended port function register (EPFR) to select the pin.

# MB9A110 Series

## ● FPT-80P-M21/FPT-80P-M37

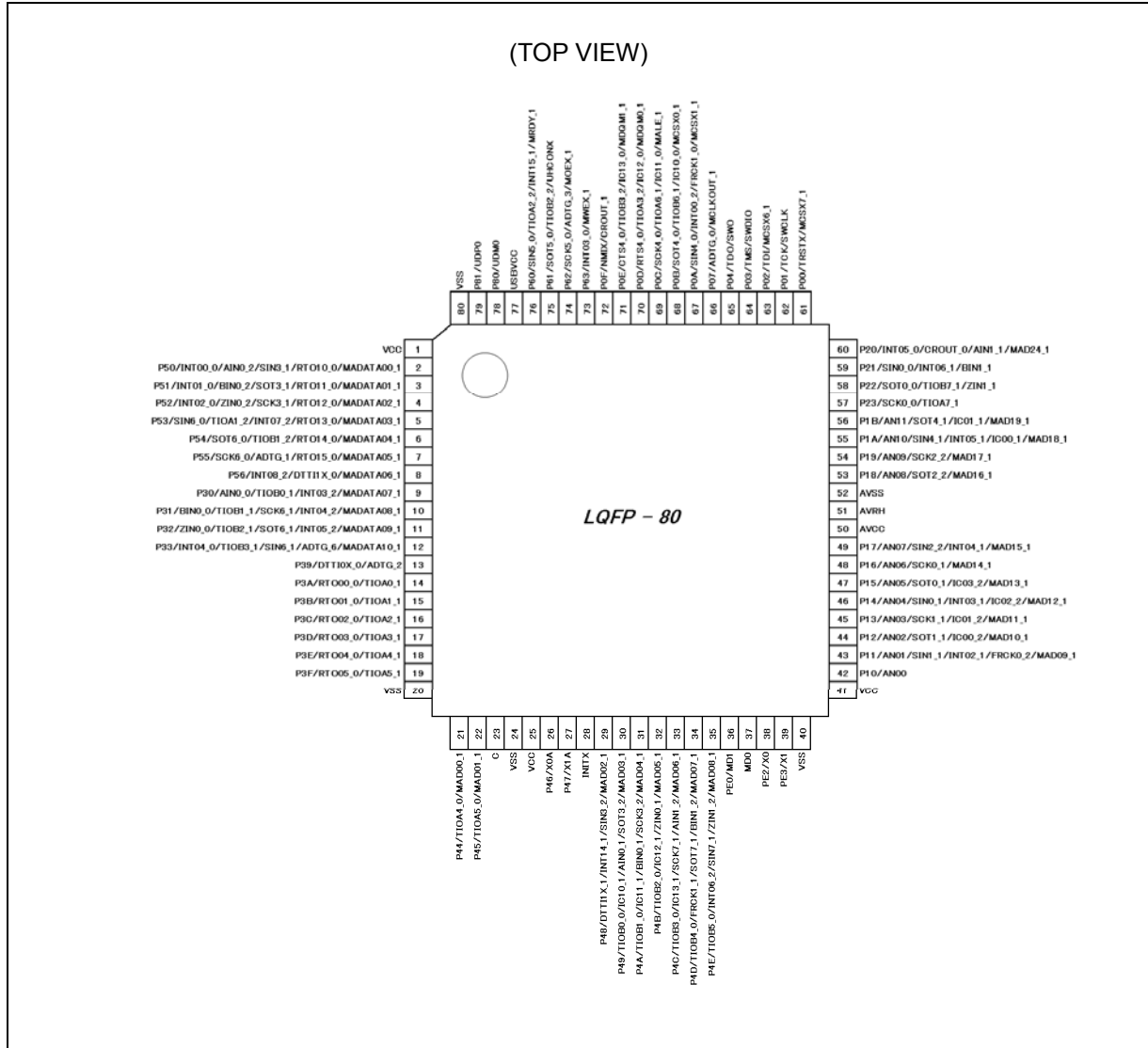

### <Note>

The number after the underscore ("\_") in pin names such as XXX\_1 and XXX\_2 indicates the relocated port number. For these pins, there are multiple pins that provide the same function for the same channel. Use the extended port function register (EPFR) to select the pin.

## ● FPT-64P-M23/M24/M38/M39

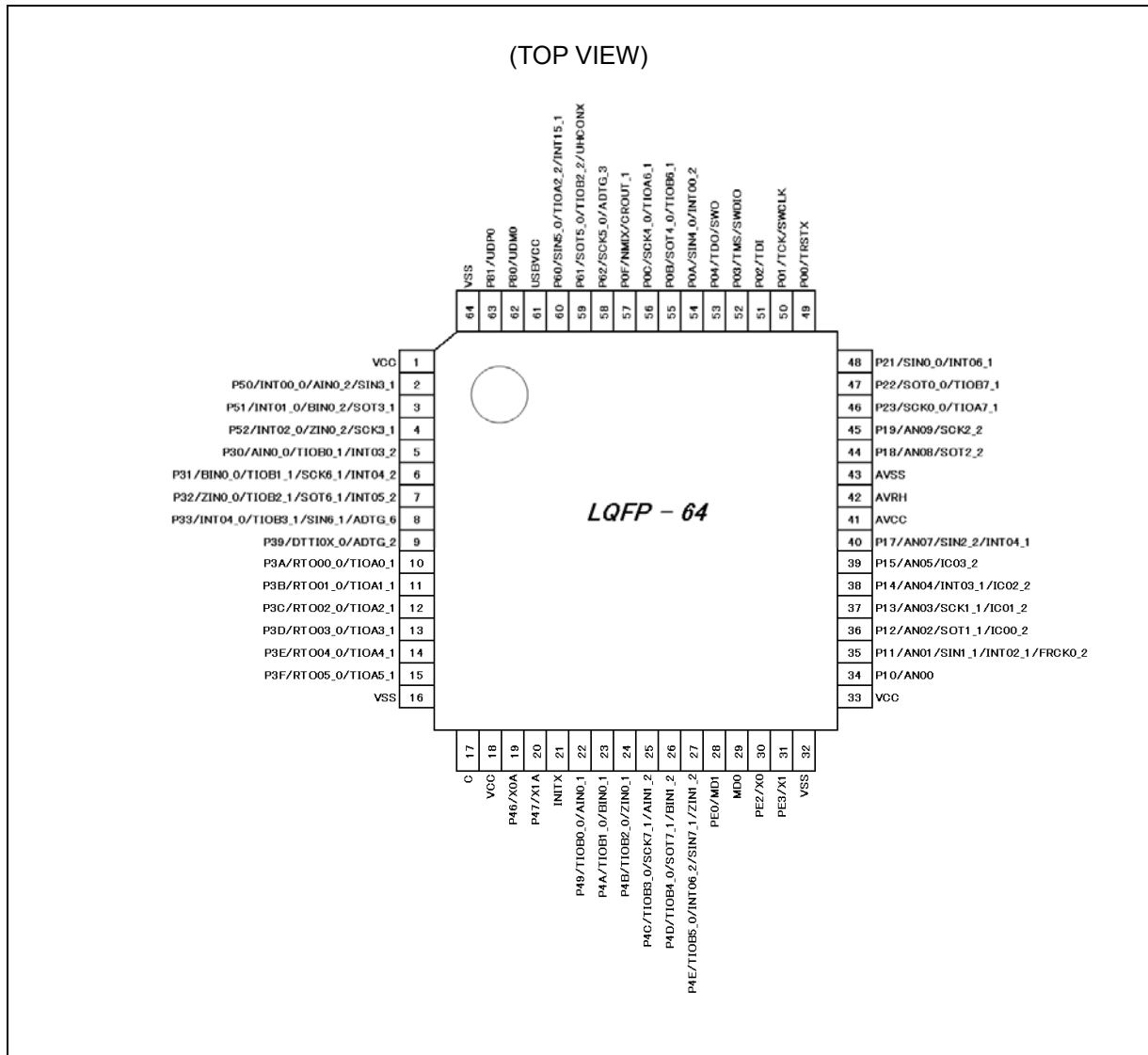

### <Note>

The number after the underscore ("\_") in pin names such as XXX\_1 and XXX\_2 indicates the relocated port number. For these pins, there are multiple pins that provide the same function for the same channel. Use the extended port function register (EPFR) to select the pin.

# MB9A110 Series

## ● BGA-112P-M04

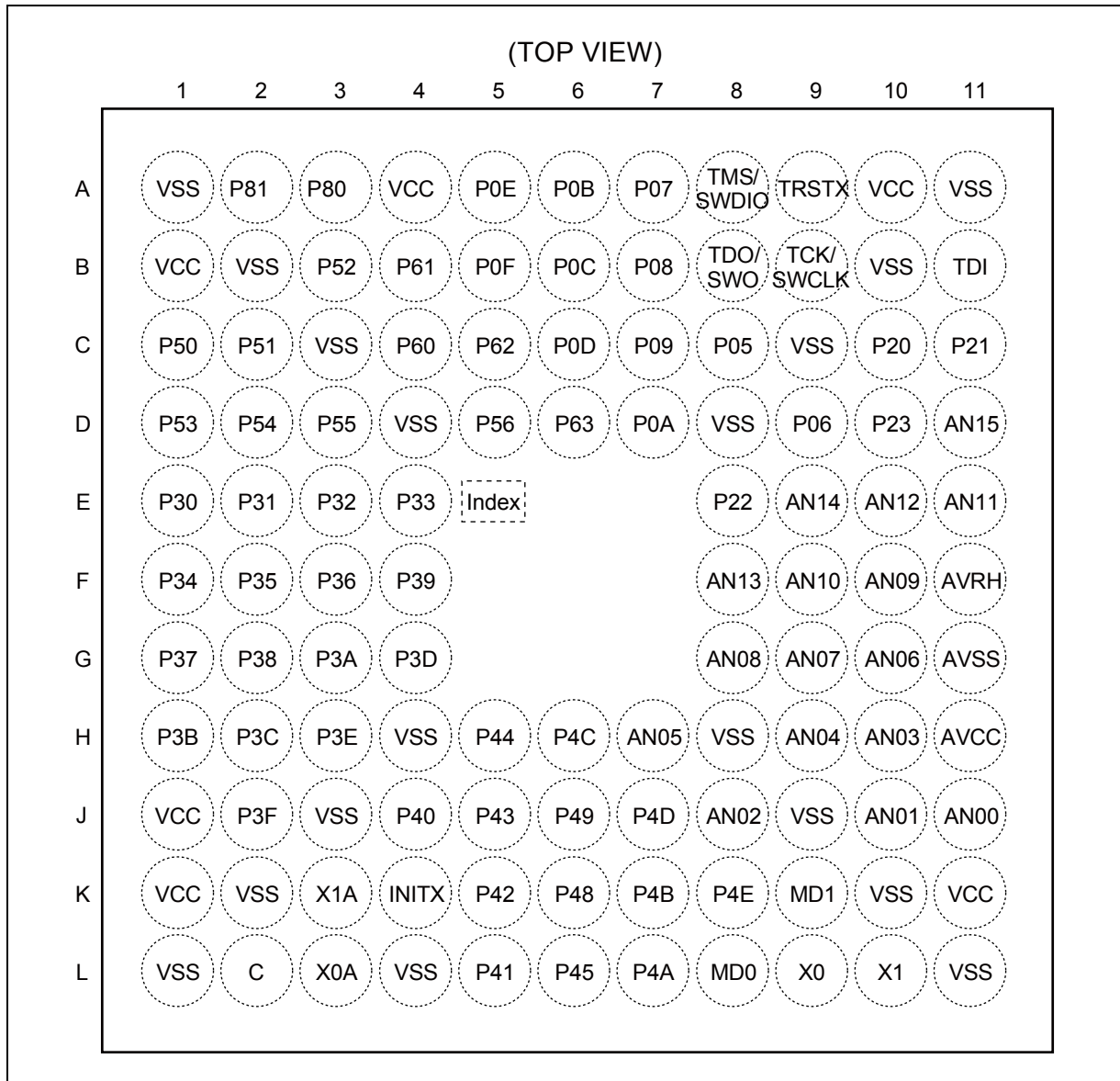

### <Note>

The number after the underscore ("\_") in pin names such as XXX\_1 and XXX\_2 indicates the relocated port number. For these pins, there are multiple pins that provide the same function for the same channel. Use the extended port function register (EPFR) to select the pin.

# MB9A110 Series

## ■ PIN DESCRIPTION

Pin No					Pin name	I/O circuit type	Pin state type
LQFP-100	QFP-100	BGA-112	LQFP-80	LQFP-64			
1	79	B1	1	1	VCC	-	
2	80	C1	2	2	P50	E	H
					INT00_0		
					AIN0_2		
				-	SIN3_1		
					RTO10_0 (PPG10_0)		
					MADATA00_1		
3	81	C2	3	3	P51	E	H
					INT01_0		
					BIN0_2		
				-	SOT3_1 (SDA3_1)		
					RTO11_0 (PPG10_0)		
					MADATA01_1		
4	82	B3	4	4	P52	E	H
					INT02_0		
					ZIN0_2		
				-	SCK3_1 (SCL3_1)		
					RTO12_0 (PPG12_0)		
					MADATA02_1		
5	83	D1	5	-	P53	E	H
					SIN6_0		
					TIOA1_2		
					INT07_2		
					RTO13_0 (PPG12_0)		
					MADATA03_1		
6	84	D2	6	-	P54	E	I
					SOT6_0 (SDA6_0)		
					TIOB1_2		
					RTO14_0 (PPG14_0)		
					MADATA04_1		

# MB9A110 Series

Pin No					Pin name	I/O circuit type	Pin state type
LQFP-100	QFP-100	BGA-112	LQFP-80	LQFP-64			
7	85	D3	7	-	P55	E	I
					SCK6_0 (SCL6_0)		
					ADTG_1		
					RTO15_0 (PPG14_0)		
					MADATA05_1		
8	86	D5	8	-	P56	E	H
					INT08_2		
					DTT11X_0		
					MADATA06_1		
9	87	E1	9	5	P30	E	H
					AIN0_0		
					TIOB0_1		
					INT03_2		
				-	MADATA07_1		
10	88	E2	10	6	P31	E	H
					BIN0_0		
					TIOB1_1		
					SCK6_1 (SCL6_1)		
					INT04_2		
				-	MADATA08_1		
11	89	E3	11	7	P32	E	H
					ZIN0_0		
					TIOB2_1		
					SOT6_1 (SDA6_1)		
					INT05_2		
				-	MADATA09_1		
12	90	E4	12	8	P33	E	H
					INT04_0		
					TIOB3_1		
					SIN6_1		
					ADTG_6		
				-	MADATA10_1		
13	91	F1	-	-	P34	E	I
					FRCK0_0		
					TIOB4_1		
					MADATA11_1		



# MB9A110 Series

Pin No					Pin name	I/O circuit type	Pin state type
LQFP-100	QFP-100	BGA-112	LQFP-80	LQFP-64			
14	92	F2	-	-	P35	E	H
					IC03_0		
					TIOB5_1		
					INT08_1		
15	93	F3	-	-	MADATA12_1	E	H
					P36		
					IC02_0		
					SIN5_2		
16	94	G1	-	-	INT09_1	E	H
					MADATA13_1		
					P37		
					IC01_0		
17	95	G2	-	-	SOT5_2 (SDA5_2)	E	H
					INT10_1		
					MADATA14_1		
					P38		
18	96	F4	13	9	IC00_0	E	I
					SCK5_2 (SCL5_2)		
					INT11_1		
					MADATA15_1		
19	97	G3	14	10	P39	G	I
					DTTIOX_0		
					ADTG_2		
20	98	H1	15	11	P3A	G	I
					RTO00_0 (PPG00_0)		
					TIOA0_1		
21	99	H2	16	12	P3B	G	I
					RTO01_0 (PPG00_0)		
					TIOA1_1		
22	100	G4	17	13	P3C	G	I
					RTO02_0 (PPG02_0)		
					TIOA2_1		
-	-	B2	-	-	P3D	G	I
					RTO03_0 (PPG02_0)		
					TIOA3_1		
-	-	B2	-	-	VSS	-	-

# MB9A110 Series

Pin No					Pin name	I/O circuit type	Pin state type
LQFP-100	QFP-100	BGA-112	LQFP-80	LQFP-64			
23	1	H3	18	14	P3E	G	I
					RTO04_0 (PPG04_0)		
					TIOA4_1		
24	2	J2	19	15	P3F	G	I
					RTO05_0 (PPG04_0)		
					TIOA5_1		
25	3	L1	20	16	VSS	-	
26	4	J1	-	-	VCC	-	
27	5	J4	-	-	P40	G	H
					TIOA0_0		
					RTO10_1 (PPG10_1)		
					INT12_1		
28	6	L5	-	-	P41	G	H
					TIOA1_0		
					RTO11_1 (PPG10_1)		
					INT13_1		
29	7	K5	-	-	P42	G	I
					TIOA2_0		
					RTO12_1 (PPG12_1)		
30	8	J5	-	-	P43	G	I
					TIOA3_0		
					RTO13_1 (PPG12_1)		
					ADTG_7		
31	9	H5	21	-	P44	G	I
					TIOA4_0		
					MAD00_1		
			-		RTO14_1 (PPG14_1)		
32	10	L6	22	-	P45	G	I
					TIOA5_0		
					MAD01_1		
			-		RTO15_1 (PPG14_1)		
-	-	K2	-	-	VSS	-	
-	-	J3	-	-	VSS	-	
-	-	H4	-	-	VSS	-	

# MB9A110 Series

Pin No					Pin name	I/O circuit type	Pin state type
LQFP-100	QFP-100	BGA-112	LQFP-80	LQFP-64			
33	11	L2	23	17	C	-	
34	12	L4	24	-	VSS	-	
35	13	K1	25	18	VCC	-	
36	14	L3	26	19	P46	D	M
					X0A		
37	15	K3	27	20	P47	D	N
					X1A		
38	16	K4	28	21	INITX	B	C
39	17	K6	29	-	P48	E	H
					DTTI1X_1		
					INT14_1		
					SIN3_2		
					MAD02_1		
40	18	J6	30	22	P49	E	I
					TIOB0_0		
				-	AIN0_1		
					IC10_1		
					SOT3_2 (SDA3_2)		
MAD03_1							
41	19	L7	31	23	P4A	E	I
					TIOB1_0		
				-	BIN0_1		
					IC11_1		
					SCK3_2 (SCL3_2)		
MAD04_1							
42	20	K7	32	24	P4B	E	I
					TIOB2_0		
				-	ZIN0_1		
					IC12_1		
MAD05_1							
43	21	H6	33	25	P4C	E / I*	I
					TIOB3_0		
					SCK7_1 (SCL7_1)		
				-	AIN1_2		
					IC13_1		
					MAD06_1		

# MB9A110 Series

Pin No					Pin name	I/O circuit type	Pin state type
LQFP-100	QFP-100	BGA-112	LQFP-80	LQFP-64			
44	22	J7	34	26	P4D	E / I*	I
					TIOB4_0		
					SOT7_1 (SDA7_1)		
				-	BIN1_2		
					FRCK1_1		
					MAD07_1		
45	23	K8	35	27	P4E	E / I*	I
					TIOB5_0		
					INT06_2		
					SIN7_1		
					ZIN1_2		
				-	MAD08_1		
46	24	K9	36	28	MD1	C	P
					PE0		
47	25	L8	37	29	MD0	J	D
48	26	L9	38	30	X0	A	A
					PE2		
49	27	L10	39	31	X1	A	B
					PE3		
50	28	L11	40	32	VSS	-	
51	29	K11	41	33	VCC	-	
52	30	J11	42	34	P10	F	K
					AN00		
53	31	J10	43	35	P11	F	L
					AN01		
					SIN1_1		
					INT02_1		
					FRCK0_2		
				-	MAD09_1		
54	32	J8	44	36	P12	F	K
					AN02		
					SOT1_1 (SDA1_1)		
					IC00_2		
					-		
				-	-		
-	-	J9	-	-	VSS	-	

# MB9A110 Series

Pin No					Pin name	I/O circuit type	Pin state type
LQFP-100	QFP-100	BGA-112	LQFP-80	LQFP-64			
55	33	H10	45	37	P13	F	K
					AN03		
					SCK1_1 (SCL1_1)		
					IC01_2		
				-	MAD11_1		
56	34	H9	46	38	P14	F	L
					AN04		
					INT03_1		
					IC02_2		
					SIN0_1		
					MAD12_1		
				-			
57	35	H7	47	39	P15	F	K
					AN05		
					IC03_2		
					SOT0_1 (SDA0_1)		
					MAD13_1		
				-			
58	36	G10	48	-	P16	F	K
					AN06		
					SCK0_1 (SCL0_1)		
					MAD14_1		
59	37	G9	49	40	P17	F	L
					AN07		
					SIN2_2		
					INT04_1		
					MAD15_1		
				-			
60	38	H11	50	41	AVCC	-	
61	39	F11	51	42	AVRH	-	
62	40	G11	52	43	AVSS	-	
63	41	G8	53	44	P18	F	K
					AN08		
					SOT2_2 (SDA2_2)		
					MAD16_1		
				-			
64	42	F10	54	45	P19	F	K
					AN09		
					SCK2_2 (SCL2_2)		
					MAD17_1		
-	-	H8	-	-	VSS	-	

# MB9A110 Series

Pin No					Pin name	I/O circuit type	Pin state type
LQFP-100	QFP-100	BGA-112	LQFP-80	LQFP-64			
65	43	F9	55	-	P1A	F	L
					AN10		
					SIN4_1		
					INT05_1		
					IC00_1		
					MAD18_1		
66	44	E11	56	-	P1B	F	K
					AN11		
					SOT4_1 (SDA4_1)		
					IC01_1		
					MAD19_1		
67	45	E10	-	-	P1C	F	K
					AN12		
					SCK4_1 (SCL4_1)		
					IC02_1		
					MAD20_1		
68	46	F8	-	-	P1D	F	K
					AN13		
					CTS4_1		
					IC03_1		
					MAD21_1		
69	47	E9	-	-	P1E	F	K
					AN14		
					RTS4_1		
					DTTI0X_1		
					MAD22_1		
70	48	D11	-	-	P1F	F	K
					AN15		
					ADTG_5		
					FRCK0_1		
					MAD23_1		
-	-	B10	-	-	VSS	-	-
-	-	C9	-	-	VSS	-	-

# MB9A110 Series

Pin No					Pin name	I/O circuit type	Pin state type
LQFP-100	QFP-100	BGA-112	LQFP-80	LQFP-64			
71	49	D10	57	46	P23	E	I
					SCK0_0 (SCL0_0)		
			TIOA7_1				
			-	-	RTO00_1 (PPG00_1)		
72	50	E8	58	47	P22	E	I
					SOT0_0 (SDA0_0)		
				TIOB7_1			
				-	ZIN1_1		
73	51	C11	59	48	P21	E	H
					SIN0_0		
				INT06_1			
				-	BIN1_1		
74	52	C10	60		P20	E	H
					INT05_0		
					CROUT_0		
					AIN1_1		
					MAD24_1		
75	53	A11	-	-	VSS	-	
76	54	A10	-	-	VCC	-	
77	55	A9	61	49	P00	E	E
					TRSTX		
				-	MCSX7_1		
78	56	B9	62	50	P01	E	E
					TCK		
					SWCLK		
79	57	B11	63	51	P02	E	E
					TDI		
					-		
80	58	A8	64	52	P03	E	E
					TMS		
					SWDIO		
81	59	B8	65	53	P04	E	E
					TDO		
					SWO		
82	60	C8			P05	E	F
					TRACED0		
					TIOA5_2		
					SIN4_2		
					INT00_1		
					MCSX5_1		
-	-	D8	-	-	VSS	-	

# MB9A110 Series

Pin No					Pin name	I/O circuit type	Pin state type
LQFP-100	QFP-100	BGA-112	LQFP-80	LQFP-64			
83	61	D9	-	-	P06	E	F
					TRACED1		
					TIOB5_2		
					SOT4_2 (SDA4_2)		
					INT01_1		
					MCSX4_1		
84	62	A7	66	-	P07	E	G
					ADTG_0		
			MCLKOUT_1				
			TRACED2				
			SCK4_2 (SCL4_2)				
-							
85	63	B7	-	-	P08	E	G
					TRACED3		
					TIOA0_2		
					CTS4_2		
					MCSX3_1		
86	64	C7	-	-	P09	E	G
					TRACECLK		
					TIOB0_2		
					RTS4_2		
					MCSX2_1		
87	65	D7	67	54	P0A	E / I*	H
					SIN4_0		
				INT00_2			
				FRCK1_0			
				MCSX1_1			
-							
88	66	A6	68	55	P0B	E / I*	I
					SOT4_0 (SDA4_0)		
				TIOB6_1			
				IC10_0			
				MCSX0_1			
-							
89	67	B6	69	56	P0C	E / I*	I
					SCK4_0 (SCL4_0)		
				TIOA6_1			
				IC11_0			
				MALE_1			
-							
-	-	D4	-	-	VSS	-	-
-	-	C3	-	-	VSS	-	-



# MB9A110 Series

Pin No					Pin name	I/O circuit type	Pin state type
LQFP-100	QFP-100	BGA-112	LQFP-80	LQFP-64			
90	68	C6	70	-	P0D	E	I
					RTS4_0		
					TIOA3_2		
					IC12_0		
					MDQM0_1		
91	69	A5	71	-	P0E	E	I
					CTS4_0		
					TIOB3_2		
					IC13_0		
					MDQM1_1		
92	70	B5	72	57	P0F	E	J
					NMIX		
					CROUT_1		
93	71	D6	73	-	P63	E	H
					INT03_0		
					MWEX_1		
94	72	C5	74	58	P62	E	I
					SCK5_0 (SCL5_0)		
				ADTG_3			
				-	MOEX_1		
95	73	B4	75	59	P61	E	I
					SOT5_0 (SDA5_0)		
					TIOB2_2		
96	74	C4	76	60	P60	E / I*	H
					SIN5_0		
					TIOA2_2		
				INT15_1			
				-	MRDY_1		
97	75	A4	77	61	VCC	-	
98	76	A3	78	62	P80	H	O
99	77	A2	79	63	P81	H	O
100	78	A1	80	64	VSS	-	

\* : 5V tolerant I/O on MB9AF115M/N, MB9AF116M/N

The number after the underscore ("\_") in pin names such as XXX\_1 and XXX\_2 indicates the relocated port number. For these pins, there are multiple pins that provide the same function for the same channel. Use the extended port function register (EPFR) to select the pin.

# MB9A110 Series

## ■ SIGNAL DESCRIPTION

Module	Pin name	Function	Pin No				
			LQFP-100	QFP-100	BGA-112	LQFP-80	LQFP-64
ADC	ADTG_0	A/D converter external trigger input pin	84	62	A7	66	-
	ADTG_1		7	85	D3	7	-
	ADTG_2		18	96	F4	13	9
	ADTG_3		94	72	C5	74	58
	ADTG_4		-	-	-	-	-
	ADTG_5		70	48	D11	-	-
	ADTG_6		12	90	E4	12	8
	ADTG_7		30	8	J5	-	-
	ADTG_8		-	-	-	-	-
	AN00	A/D converter analog input pin ANxx describes ADC ch.xx.	52	30	J11	42	34
	AN01		53	31	J10	43	35
	AN02		54	32	J8	44	36
	AN03		55	33	H10	45	37
	AN04		56	34	H9	46	38
	AN05		57	35	H7	47	39
	AN06		58	36	G10	48	-
	AN07		59	37	G9	49	40
	AN08		63	41	G8	53	44
	AN09		64	42	F10	54	45
	AN10		65	43	F9	55	-
AN11	66		44	E11	56	-	
AN12	67		45	E10	-	-	
AN13	68		46	F8	-	-	
AN14	69		47	E9	-	-	
AN15	70		48	D11	-	-	
Base Timer 0	TIOA0_0	Base timer ch.0 TIOA pin	27	5	J4	-	-
	TIOA0_1		19	97	G3	14	10
	TIOA0_2		85	63	B7	-	-
	TIOB0_0	Base timer ch.0 TIOB pin	40	18	J6	30	22
	TIOB0_1		9	87	E1	9	5
	TIOB0_2		86	64	C7	-	-
Base Timer 1	TIOA1_0	Base timer ch.1 TIOA pin	28	6	L5	-	-
	TIOA1_1		20	98	H1	15	11
	TIOA1_2		5	83	D1	5	-
	TIOB1_0	Base timer ch.1 TIOB pin	41	19	L7	31	23
	TIOB1_1		10	88	E2	10	6
	TIOB1_2		6	84	D2	6	-
Base Timer 2	TIOA2_0	Base timer ch.2 TIOA pin	29	7	K5	-	-
	TIOA2_1		21	99	H2	16	12
	TIOA2_2		96	74	C4	76	60
	TIOB2_0	Base timer ch.2 TIOB pin	42	20	K7	32	24
	TIOB2_1		11	89	E3	11	7
	TIOB2_2		95	73	B4	75	59

# MB9A110 Series

Module	Pin name	Function	Pin No				
			LQFP-100	QFP-100	BGA-112	LQFP-80	LQFP-64
Base Timer 3	TIOA3_0	Base timer ch.3 TIOA pin	30	8	J5	-	-
	TIOA3_1		22	100	G4	17	13
	TIOA3_2		90	68	C6	70	-
	TIOB3_0	Base timer ch.3 TIOB pin	43	21	H6	33	25
	TIOB3_1		12	90	E4	12	8
	TIOB3_2		91	69	A5	71	-
Base Timer 4	TIOA4_0	Base timer ch.4 TIOA pin	31	9	H5	21	-
	TIOA4_1		23	1	H3	18	14
	TIOA4_2		-	-	-	-	-
	TIOB4_0	Base timer ch.4 TIOB pin	44	22	J7	34	26
	TIOB4_1		13	91	F1	-	-
	TIOB4_2		-	-	-	-	-
Base Timer 5	TIOA5_0	Base timer ch.5 TIOA pin	32	10	L6	22	-
	TIOA5_1		24	2	J2	19	15
	TIOA5_2		82	60	C8	-	-
	TIOB5_0	Base timer ch.5 TIOB pin	45	23	K8	35	27
	TIOB5_1		14	92	F2	-	-
	TIOB5_2		83	61	D9	-	-
Base Timer 6	TIOA6_1	Base timer ch.6 TIOA pin	89	67	B6	69	56
	TIOB6_1	Base timer ch.6 TIOB pin	88	66	A6	68	55
Base Timer 7	TIOA7_0	Base timer ch.7 TIOA pin	-	-	-	-	-
	TIOA7_1		71	49	D10	57	46
	TIOA7_2		-	-	-	-	-
	TIOB7_0	Base timer ch.7 TIOB pin	-	-	-	-	-
	TIOB7_1		72	50	E8	58	47
	TIOB7_2		-	-	-	-	-

# MB9A110 Series

Module	Pin name	Function	Pin No				
			LQFP-100	QFP-100	BGA-112	LQFP-80	LQFP-64
Debugger	SWCLK	Serial wire debug interface clock input	78	56	B9	62	50
	SWDIO	Serial wire debug interface data input / output	80	58	A8	64	52
	SWO	Serial wire viewer output	81	59	B8	65	53
	TCK	J-TAG test clock input	78	56	B9	62	50
	TDI	J-TAG test data input	79	57	B11	63	51
	TDO	J-TAG debug data output	81	59	B8	65	53
	TMS	J-TAG test mode state input/output	80	58	A8	64	52
	TRACECLK	Trace CLK output of ETM	86	64	C7	-	-
	TRACED0	Trace data output of ETM	82	60	C8	-	-
	TRACED1		83	61	D9	-	-
	TRACED2		84	62	A7	-	-
	TRACED3		85	63	B7	-	-
	TRSTX	J-TAG test reset Input	77	55	A9	61	49
	External Bus	MAD00_1	External bus interface address bus	31	9	H5	21
MAD01_1		32		10	L6	22	-
MAD02_1		39		17	K6	29	-
MAD03_1		40		18	J6	30	-
MAD04_1		41		19	L7	31	-
MAD05_1		42		20	K7	32	-
MAD06_1		43		21	H6	33	-
MAD07_1		44		22	J7	34	-
MAD08_1		45		23	K8	35	-
MAD09_1		53		31	J10	43	-
MAD10_1		54		32	J8	44	-
MAD11_1		55		33	H10	45	-
MAD12_1		56		34	H9	46	-
MAD13_1		57		35	H7	47	-
MAD14_1		58		36	G10	48	-
MAD15_1		59		37	G9	49	-
MAD16_1		63		41	G8	53	-
MAD17_1		64		42	F10	54	-
MAD18_1		65		43	F9	55	-
MAD19_1		66		44	E11	56	-
MAD20_1		67		45	E10	-	-
MAD21_1		68		46	F8	-	-
MAD22_1		69		47	E9	-	-
MAD23_1		70		48	D11	-	-
MAD24_1	74	52	C10	60	-		

# MB9A110 Series

Module	Pin name	Function	Pin No				
			LQFP-100	QFP-100	BGA-112	LQFP-80	LQFP-64
External Bus	MCSX0_1	External bus interface chip select output pin	88	66	A6	68	-
	MCSX1_1		87	65	D7	67	-
	MCSX2_1		86	64	C7	-	-
	MCSX3_1		85	63	B7	-	-
	MCSX4_1		83	61	D9	-	-
	MCSX5_1		82	60	C8	-	-
	MCSX6_1		79	57	B11	63	-
	MCSX7_1		77	55	A9	61	-
	MDQM0_1	External bus interface byte mask signal output	90	68	C6	70	-
	MDQM1_1		91	69	A5	71	-
	MOEX_1	External bus interface read enable signal for SRAM	94	72	C5	74	-
	MWEX_1	External bus interface write enable signal for SRAM	93	71	D6	73	-
	MADATA00_1	External bus interface data bus	2	80	C1	2	-
	MADATA01_1		3	81	C2	3	-
	MADATA02_1		4	82	B3	4	-
	MADATA03_1		5	83	D1	5	-
	MADATA04_1		6	84	D2	6	-
	MADATA05_1		7	85	D3	7	-
	MADATA06_1		8	86	D5	8	-
	MADATA07_1		9	87	E1	9	-
	MADATA08_1		10	88	E2	10	-
	MADATA09_1		11	89	E3	11	-
	MADATA10_1		12	90	E4	12	-
	MADATA11_1		13	91	F1	-	-
	MADATA12_1		14	92	F2	-	-
	MADATA13_1		15	93	F3	-	-
	MADATA14_1		16	94	G1	-	-
	MADATA15_1		17	95	G2	-	-
	MALE_1	External bus interface Address Latch enable output signal for multiplex	89	67	B6	69	-
	MRDY_1	External bus interface external RDY input signal	96	74	C4	76	-
	MCLKOUT_1	External bus interface external clock output	84	62	A7	66	-

# MB9A110 Series

Module	Pin name	Function	Pin No				
			LQFP-100	QFP-100	BGA-112	LQFP-80	LQFP-64
External Interrupt	INT00_0	External interrupt request 00 input pin	2	80	C1	2	2
	INT00_1		82	60	C8	-	-
	INT00_2		87	65	D7	67	54
	INT01_0	External interrupt request 01 input pin	3	81	C2	3	3
	INT01_1		83	61	D9	-	-
	INT02_0	External interrupt request 02 input pin	4	82	B3	4	4
	INT02_1		53	31	J10	43	35
	INT03_0	External interrupt request 03 input pin	93	71	D6	73	-
	INT03_1		56	34	H9	46	38
	INT03_2		9	87	E1	9	5
	INT04_0	External interrupt request 04 input pin	12	90	E4	12	8
	INT04_1		59	37	G9	49	40
	INT04_2		10	88	E2	10	6
	INT05_0	External interrupt request 05 input pin	74	52	C10	60	-
	INT05_1		65	43	F9	55	-
	INT05_2		11	89	E3	11	7
	INT06_1	External interrupt request 06 input pin	73	51	C11	59	48
	INT06_2		45	23	K8	35	27
	INT07_2	External interrupt request 07 input pin	5	83	D1	5	-
	INT08_1	External interrupt request 08 input pin	14	92	F2	-	-
	INT08_2		8	86	D5	8	-
	INT09_1	External interrupt request 09 input pin	15	93	F3	-	-
	INT10_1	External interrupt request 10 input pin	16	94	G1	-	-
INT11_1	External interrupt request 11 input pin	17	95	G2	-	-	
INT12_1	External interrupt request 12 input pin	27	5	J4	-	-	
INT13_1	External interrupt request 13 input pin	28	6	L5	-	-	
INT14_1	External interrupt request 14 input pin	39	17	K6	29	-	
INT15_1	External interrupt request 15 input pin	96	74	C4	76	60	
NMIX	Non-Maskable Interrupt input	92	70	B5	72	57	

# MB9A110 Series

Module	Pin name	Function	Pin No				
			LQFP-100	QFP-100	BGA-112	LQFP-80	LQFP-64
GPIO	P00	General-purpose I/O port 0	77	55	A9	61	49
	P01		78	56	B9	62	50
	P02		79	57	B11	63	51
	P03		80	58	A8	64	52
	P04		81	59	B8	65	53
	P05		82	60	C8	-	-
	P06		83	61	D9	-	-
	P07		84	62	A7	66	-
	P08		85	63	B7	-	-
	P09		86	64	C7	-	-
	P0A		87	65	D7	67	54
	P0B		88	66	A6	68	55
	P0C		89	67	B6	69	56
	P0D		90	68	C6	70	-
	P0E		91	69	A5	71	-
	P0F		92	70	B5	72	57
	P10	General-purpose I/O port 1	52	30	J11	42	34
	P11		53	31	J10	43	35
	P12		54	32	J8	44	36
	P13		55	33	H10	45	37
	P14		56	34	H9	46	38
	P15		57	35	H7	47	39
	P16		58	36	G10	48	-
	P17		59	37	G9	49	40
	P18		63	41	G8	53	44
	P19		64	42	F10	54	45
	P1A		65	43	F9	55	-
	P1B		66	44	E11	56	-
	P1C		67	45	E10	-	-
	P1D		68	46	F8	-	-
P1E	69	47	E9	-	-		
P1F	70	48	D11	-	-		
P20	General-purpose I/O port 2	74	52	C10	60	-	
P21		73	51	C11	59	48	
P22		72	50	E8	58	47	
P23		71	49	D10	57	46	

# MB9A110 Series

Module	Pin name	Function	Pin No					
			LQFP-100	QFP-100	BGA-112	LQFP-80	LQFP-64	
GPIO	P30	General-purpose I/O port 3	9	87	E1	9	5	
	P31		10	88	E2	10	6	
	P32		11	89	E3	11	7	
	P33		12	90	E4	12	8	
	P34		13	91	F1	-	-	
	P35		14	92	F2	-	-	
	P36		15	93	F3	-	-	
	P37		16	94	G1	-	-	
	P38		17	95	G2	-	-	
	P39		18	96	F4	13	9	
	P3A		19	97	G3	14	10	
	P3B		20	98	H1	15	11	
	P3C		21	99	H2	16	12	
	P3D		22	100	G4	17	13	
	P3E		23	1	H3	18	14	
	P3F		24	2	J2	19	15	
	P40		27	General-purpose I/O port 4	5	J4	-	-
	P41		28		6	L5	-	-
	P42		29		7	K5	-	-
	P43		30		8	J5	-	-
	P44		31		9	H5	21	-
	P45		32		10	L6	22	-
	P46		36		14	L3	26	19
	P47		37		15	K3	27	20
	P48	39	17		K6	29	-	
	P49	40	18		J6	30	22	
	P4A	41	19		L7	31	23	
	P4B	42	20		K7	32	24	
	P4C	43	21		H6	33	25	
	P4D	44	22		J7	34	26	
	P4E	45	23		K8	35	27	
	P50	2	General-purpose I/O port 5	80	C1	2	2	
	P51	3		81	C2	3	3	
	P52	4		82	B3	4	4	
	P53	5		83	D1	5	-	
	P54	6		84	D2	6	-	
	P55	7		85	D3	7	-	
	P56	8		86	D5	8	-	
	P60	96		74	C4	76	60	
	P61	95	73	B4	75	59		
	P62	94	72	C5	74	58		
	P63	93	71	D6	73	-		
	P80	98	76	A3	78	62		
	P81	99	77	A2	79	63		
	PE0	46	24	K9	36	28		
	PE2	48	26	L9	38	30		
	PE3	49	27	L10	39	31		



# MB9A110 Series

Module	Pin name	Function	Pin No				
			LQFP-100	QFP-100	BGA-112	LQFP-80	LQFP-64
Multi Function Serial 0	SIN0_0	Multifunction serial interface ch.0 input pin	73	51	C11	59	48
	SIN0_1		56	34	H9	46	-
	SOT0_0 (SDA0_0)	Multifunction serial interface ch.0 output pin	72	50	E8	58	47
	SOT0_1 (SDA0_1)	This pin operates as SOT0 when it is used in a UART/CSIO (operation modes 0 to 2) and as SDA0 when it is used in an I <sup>2</sup> C (operation mode 4).	57	35	H7	47	-
	SCK0_0 (SCL0_0)	Multifunction serial interface ch.0 clock I/O pin	71	49	D10	57	46
	SCK0_1 (SCL0_1)	This pin operates as SCK0 when it is used in a UART/CSIO (operation modes 0 to 2) and as SCL0 when it is used in an I <sup>2</sup> C (operation mode 4).	58	36	G10	48	-
Multi Function Serial 1	SIN1_1	Multifunction serial interface ch.1 input pin	53	31	J10	43	35
	SOT1_1 (SDA1_1)	Multifunction serial interface ch.1 output pin This pin operates as SOT1 when it is used in a UART/CSIO (operation modes 0 to 2) and as SDA1 when it is used in an I <sup>2</sup> C (operation mode 4).	54	32	J8	44	36
	SCK1_1 (SCL1_1)	Multifunction serial interface ch.1 clock I/O pin This pin operates as SCK1 when it is used in a UART/CSIO (operation modes 0 to 2) and as SCL1 when it is used in an I <sup>2</sup> C (operation mode 4).	55	33	H10	45	37

# MB9A110 Series

Module	Pin name	Function	Pin No				
			LQFP-100	QFP-100	BGA-112	LQFP-80	LQFP-64
Multi Function Serial 2	SIN2_2	Multifunction serial interface ch.2 input pin	59	37	G9	49	40
	SOT2_2 (SDA2_2)	Multifunction serial interface ch.2 output pin This pin operates as SOT2 when it is used in a UART/CSIO (operation modes 0 to 2) and as SDA2 when it is used in an I <sup>2</sup> C (operation mode 4).	63	41	G8	53	44
	SCK2_2 (SCL2_2)	Multifunction serial interface ch.2 clock I/O pin This pin operates as SCK2 when it is used in a UART/CSIO (operation modes 0 to 2) and as SCL2 when it is used in an I <sup>2</sup> C (operation mode 4).	64	42	F10	54	45
Multi Function Serial 3	SIN3_1	Multifunction serial interface ch.3 input pin	2	80	C1	2	2
	SIN3_2		39	17	K6	29	-
	SOT3_1 (SDA3_1)	Multifunction serial interface ch.3 output pin This pin operates as SOT3 when it is used in a UART/CSIO (operation modes 0 to 2) and as SDA3 when it is used in an I <sup>2</sup> C (operation mode 4).	3	81	C2	3	3
	SOT3_2 (SDA3_2)		40	18	J6	30	-
	SCK3_1 (SCL3_1)	Multifunction serial interface ch.3 clock I/O pin This pin operates as SCK3 when it is used in a UART/CSIO (operation modes 0 to 2) and as SCL3 when it is used in an I <sup>2</sup> C (operation mode 4).	4	82	B3	4	4
	SCK3_2 (SCL3_2)		41	19	L7	31	-

# MB9A110 Series

Module	Pin name	Function	Pin No				
			LQFP-100	QFP-100	BGA-112	LQFP-80	LQFP-64
Multi Function Serial 4	SIN4_0	Multifunction serial interface ch.4 input pin	87	65	D7	67	54
	SIN4_1		65	43	F9	55	-
	SIN4_2		82	60	C8	-	-
	SOT4_0 (SDA4_0)	Multifunction serial interface ch.4 output pin	88	66	A6	68	55
	SOT4_1 (SDA4_1)	This pin operates as SOT4 when it is used in a UART/CSIO (operation modes 0 to 2) and as SDA4 when it is used in an I <sup>2</sup> C (operation mode 4).	66	44	E11	56	-
	SOT4_2 (SDA4_2)		83	61	D9	-	-
	SCK4_0 (SCL4_0)	Multifunction serial interface ch.4 clock I/O pin	89	67	B6	69	56
	SCK4_1 (SCL4_1)	This pin operates as SCK4 when it is used in a UART/CSIO (operation modes 0 to 2) and as SCL4 when it is used in an I <sup>2</sup> C (operation mode 4).	67	45	E10	-	-
	SCK4_2 (SCL4_2)		84	62	A7	-	-
	RTS4_0	Multifunction serial interface ch.4 RTS output pin	90	68	C6	70	-
	RTS4_1		69	47	E9	-	-
	RTS4_2		86	64	C7	-	-
	CTS4_0	Multifunction serial interface ch.4 CTS input pin	91	69	A5	71	-
	CTS4_1		68	46	F8	-	-
	CTS4_2		85	63	B7	-	-
Multi Function Serial 5	SIN5_0	Multifunction serial interface ch.5 input pin	96	74	C4	76	60
	SIN5_2		15	93	F3	-	-
	SOT5_0 (SDA5_0)	Multifunction serial interface ch.5 output pin	95	73	B4	75	59
	SOT5_2 (SDA5_2)	This pin operates as SOT5 when it is used in a UART/CSIO (operation modes 0 to 2) and as SDA5 when it is used in an I <sup>2</sup> C (operation mode 4).	16	94	G1	-	-
	SCK5_0 (SCL5_0)	Multifunction serial interface ch.5 clock I/O pin	94	72	C5	74	58
	SCK5_2 (SCL5_2)	This pin operates as SCK5 when it is used in a UART/CSIO (operation modes 0 to 2) and as SCL5 when it is used in an I <sup>2</sup> C (operation mode 4).	17	95	G2	-	-

# MB9A110 Series

Module	Pin name	Function	Pin No				
			LQFP-100	QFP-100	BGA-112	LQFP-80	LQFP-64
Multi Function Serial 6	SIN6_0	Multifunction serial interface ch.6 input pin	5	83	D1	5	-
	SIN6_1		12	90	E4	12	8
	SOT6_0 (SDA6_0)	Multifunction serial interface ch.6 output pin	6	84	D2	6	-
	SOT6_1 (SDA6_1)	This pin operates as SOT6 when it is used in a UART/CSIO (operation modes 0 to 2) and as SDA6 when it is used in an I <sup>2</sup> C (operation mode 4).	11	89	E3	11	7
	SCK6_0 (SCL6_0)	Multifunction serial interface ch.6 clock I/O pin	7	85	D3	7	-
	SCK6_1 (SCL6_1)	This pin operates as SCK6 when it is used in a UART/CSIO (operation modes 0 to 2) and as SCL6 when it is used in an I <sup>2</sup> C (operation mode 4).	10	88	E2	10	6
Multi Function Serial 7	SIN7_1	Multifunction serial interface ch.7 input pin	45	23	K8	35	27
	SOT7_1 (SDA7_1)	Multifunction serial interface ch.7 output pin This pin operates as SOT7 when it is used in a UART/CSIO (operation modes 0 to 2) and as SDA7 when it is used in an I <sup>2</sup> C (operation mode 4).	44	22	J7	34	26
	SCK7_1 (SCL7_1)	Multifunction serial interface ch.7 clock I/O pin This pin operates as SCK7 when it is used in a UART/CSIO (operation modes 0 to 2) and as SCL7 when it is used in an I <sup>2</sup> C (operation mode 4).	43	21	H6	33	25

Module	Pin name	Function	Pin No					
			LQFP-100	QFP-100	BGA-112	LQFP-80	LQFP-64	
Multi Function Timer 0	DTTI0X_0	Input signal controlling wave form generator outputs RTO00 to RTO05 of multi-function timer 0	18	96	F4	13	9	
	DTTI0X_1		69	47	E9	-	-	
	FRCK0_0	16-bit free-run timer ch.0 external clock input pin	13	91	F1	-	-	
	FRCK0_1		70	48	D11	-	-	
	FRCK0_2		53	31	J10	43	35	
	IC00_0	16-bit input capture ch.0 input pin of multi-function timer 0 ICxx describes channel number.	17	95	G2	-	-	
	IC00_1		65	43	F9	55	-	
	IC00_2		54	32	J8	44	36	
	IC01_0		16	94	G1	-	-	
	IC01_1		66	44	E11	56	-	
	IC01_2		55	33	H10	45	37	
	IC02_0		15	93	F3	-	-	
	IC02_1		67	45	E10	-	-	
	IC02_2		56	34	H9	46	38	
	IC03_0		14	92	F2	-	-	
	IC03_1		68	46	F8	-	-	
	IC03_2		57	35	H7	47	39	
	RTO00_0 (PPG00_0)		Wave form generator output of multi-function timer 0	19	97	G3	14	10
	RTO00_1 (PPG00_1)		This pin operates as PPG00 when it is used in PPG 0 output modes.	71	49	D10	-	-
	RTO01_0 (PPG00_0)		Wave form generator output of multi-function timer 0 This pin operates as PPG00 when it is used in PPG 0 output modes.	20	98	H1	15	11
	RTO02_0 (PPG02_0)	Wave form generator output of multi-function timer 0 This pin operates as PPG02 when it is used in PPG 0 output modes.	21	99	H2	16	12	
	RTO03_0 (PPG02_0)	Wave form generator output of multi-function timer 0 This pin operates as PPG02 when it is used in PPG 0 output modes.	22	100	G4	17	13	
	RTO04_0 (PPG04_0)	Wave form generator output of multi-function timer 0 This pin operates as PPG04 when it is used in PPG 0 output modes.	23	1	H3	18	14	
	RTO05_0 (PPG04_0)	Wave form generator output of multi-function timer 0 This pin operates as PPG04 when it is used in PPG 0 output modes.	24	2	J2	19	15	

# MB9A110 Series

Module	Pin name	Function	Pin No					
			LQFP-100	QFP-100	BGA-112	LQFP-80	LQFP-64	
Multi Function Timer 1	DTT1X_0	Input signal controlling wave form generator outputs RTO10 to RTO15 of multi-function timer 1	8	86	D5	8	-	
	DTT1X_1		39	17	K6	29	-	
	FRCK1_0	16-bit free-run timer ch.1 external clock input pin	87	65	D7	67	-	
	FRCK1_1		44	22	J7	34	-	
	IC10_0	16-bit input capture ch.0 input pin of multi-function timer 1 ICxx describes channel number.	88	66	A6	68	-	
	IC10_1		40	18	J6	30	-	
	IC11_0		89	67	B6	69	-	
	IC11_1		41	19	L7	31	-	
	IC12_0		90	68	C6	70	-	
	IC12_1		42	20	K7	32	-	
	IC13_0		91	69	A5	71	-	
	IC13_1		43	21	H6	33	-	
	RTO10_0 (PPG10_0)		Wave form generator output of multi-function timer 1	2	80	C1	2	-
	RTO10_1 (PPG10_1)		This pin operates as PPG10 when it is used in PPG 1 output modes.	27	5	J4	-	-
	RTO11_0 (PPG10_0)	Wave form generator output of multi-function timer 1	3	81	C2	3	-	
	RTO11_1 (PPG10_1)	This pin operates as PPG10 when it is used in PPG 1 output modes.	28	6	L5	-	-	
	RTO12_0 (PPG12_0)	Wave form generator output of multi-function timer 1	4	82	B3	4	-	
	RTO12_1 (PPG12_1)	This pin operates as PPG12 when it is used in PPG 1 output modes.	29	7	K5	-	-	
	RTO13_0 (PPG12_0)	Wave form generator output of multi-function timer 1	5	83	D1	5	-	
	RTO13_1 (PPG12_1)	This pin operates as PPG12 when it is used in PPG 1 output modes.	30	8	J5	-	-	
RTO14_0 (PPG14_0)	Wave form generator output of multi-function timer 1	6	84	D2	6	-		
RTO14_1 (PPG14_1)	This pin operates as PPG14 when it is used in PPG 1 output modes.	31	9	H5	21	-		
RTO15_0 (PPG14_0)	Wave form generator output of multi-function timer 1	7	85	D3	7	-		
RTO15_1 (PPG14_1)	This pin operates as PPG14 when it is used in PPG 1 output modes.	32	10	L6	22	-		

# MB9A110 Series

Module	Pin name	Function	Pin No				
			LQFP-100	QFP-100	BGA-112	LQFP-80	LQFP-64
Quadrature Position/ Revolution Counter 0	AIN0_0	QPRC ch.0 AIN input pin	9	87	E1	9	5
	AIN0_1		40	18	J6	30	22
	AIN0_2		2	80	C1	2	2
	BIN0_0	QPRC ch.0 BIN input pin	10	88	E2	10	6
	BIN0_1		41	19	L7	31	23
	BIN0_2		3	81	C2	3	3
	ZIN0_0	QPRC ch.0 ZIN input pin	11	89	E3	11	7
	ZIN0_1		42	20	K7	32	24
	ZIN0_2		4	82	B3	4	4
Quadrature Position/ Revolution Counter 1	AIN1_1	QPRC ch.1 AIN input pin	74	52	C10	60	-
	AIN1_2		43	21	H6	33	25
	BIN1_1	QPRC ch.1 BIN input pin	73	51	C11	59	-
	BIN1_2		44	22	J7	34	26
	ZIN1_1	QPRC ch.1 ZIN input pin	72	50	E8	58	-
	ZIN1_2		45	23	K8	35	27

# MB9A110 Series

Module	Pin name	Function	Pin No				
			LQFP-100	QFP-100	BGA-112	LQFP-80	LQFP-64
RESET	INITX	External Reset Input. A reset is valid when INITX=L	38	16	K4	28	21
Mode	MD0	Mode 0 pin During normal operation, MD0=L must be input. During serial programming to flash memory, MD0=H must be input.	47	25	L8	37	29
	MD1	Mode 1 pin During serial programming to flash memory, MD1=L must be input.	46	24	K9	36	28
POWER	VCC	Power Pin	1	79	B1	1	1
	VCC	Power Pin	26	4	J1	-	-
	VCC	Power pin	35	13	K1	25	18
	VCC	Power pin	51	29	K11	41	33
	VCC	Power pin	76	54	A10	-	-
	VCC	Power pin	97	75	A4	77	61
GND	VSS	GND Pin	-	-	B2	-	-
	VSS	GND pin	25	3	L1	20	16
	VSS	GND pin	-	-	K2	-	-
	VSS	GND pin	-	-	J3	-	-
	VSS	GND pin	-	-	H4	-	-
	VSS	GND pin	34	12	L4	24	-
	VSS	GND pin	50	28	L11	40	32
	VSS	GND pin	-	-	K10	-	-
	VSS	GND pin	-	-	J9	-	-
	VSS	GND pin	-	-	H8	-	-
	VSS	GND pin	-	-	B10	-	-
	VSS	GND pin	-	-	C9	-	-
	VSS	GND pin	75	53	A11	-	-
	VSS	GND pin	-	-	D8	-	-
	VSS	GND pin	-	-	D4	-	-
	VSS	GND pin	-	-	C3	-	-
	VSS	GND pin	100	78	A1	80	64
	CLOCK	X0	Main clock (oscillation) input pin	48	26	L9	38
X0A		Sub clock (oscillation) input pin	36	14	L3	26	19
X1		Main clock (oscillation) I/O pin	49	27	L10	39	31
X1A		Sub clock (oscillation) I/O pin	37	15	K3	27	20
CROUT_0		Internal CR-osc clock output port	74	52	C10	60	-
CROUT_1			92	70	B5	72	57
ADC POWER	AVCC	A/D converter analog power pin	60	38	H11	50	41
	AVRH	A/D converter analog reference voltage input pin	61	39	F11	51	42
ADC GND	AVSS	A/D converter GND pin	62	40	G11	52	43
C pin	C	Power stabilization capacity pin	33	11	L2	23	17

The number after the underscore ("\_") in pin names such as XXX\_1 and XXX\_2 indicates the relocated port number. For these pins, there are multiple pins that provide the same function for the same channel. Use the extended port function register (EPFR) to select the pin.



## ■ I/O CIRCUIT TYPE

Type	Circuit	Remarks
A		<ul style="list-style-type: none"> <li>• It is possible to select the main oscillation / GPIO function</li> </ul> <p>When the main oscillation is selected.</p> <ul style="list-style-type: none"> <li>• Oscillation feedback resistor : Approximately 1MΩ</li> <li>• With Standby mode control</li> </ul> <p>When the GPIO is selected.</p> <ul style="list-style-type: none"> <li>• CMOS level output.</li> <li>• CMOS level hysteresis input</li> <li>• With pull-up resistor control</li> <li>• With standby mode control</li> <li>• Pull-up resistor : Approximately 50kΩ</li> <li>• <math>I_{OH} = -4mA, I_{OL} = 4mA</math></li> </ul>
B		<ul style="list-style-type: none"> <li>• CMOS level hysteresis input</li> <li>• Pull-up resistor : Approximately 50kΩ</li> </ul>

# MB9A110 Series

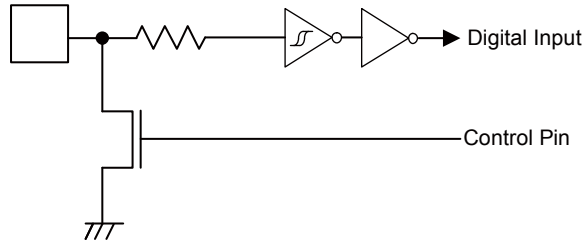
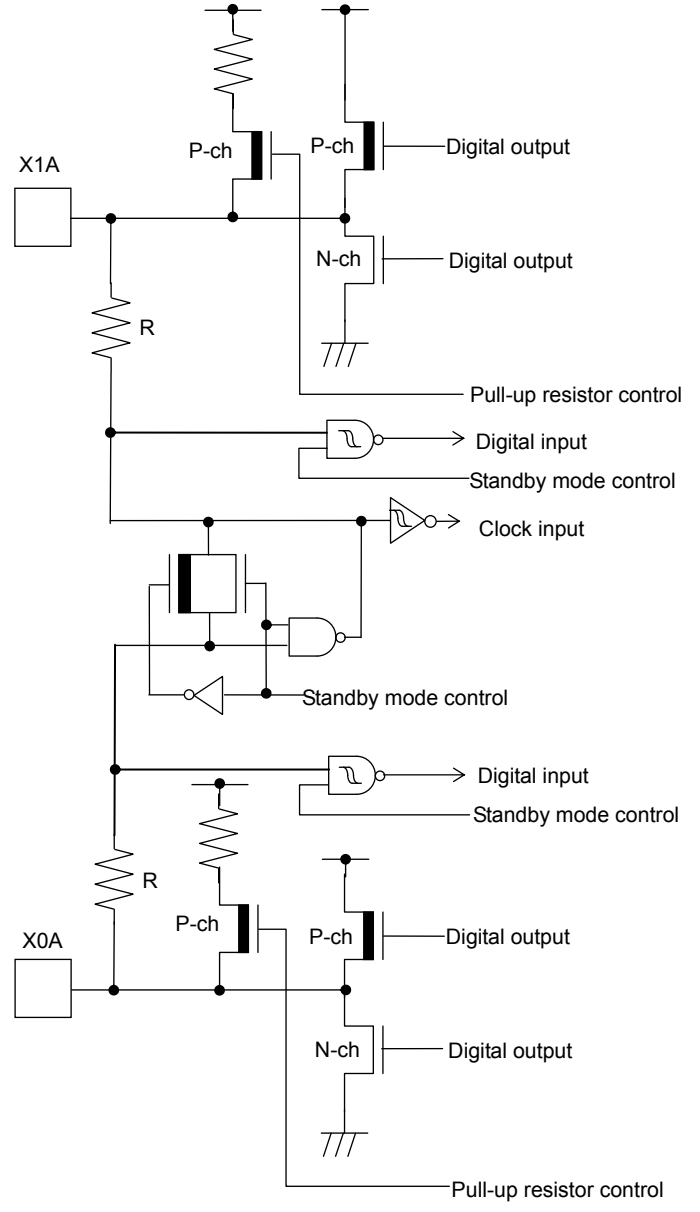
Type	Circuit	Remarks
C		<ul style="list-style-type: none"> <li>• Open drain output</li> <li>• CMOS level hysteresis input</li> </ul>
D		<ul style="list-style-type: none"> <li>• It is possible to select the sub oscillation / GPIO function</li> </ul> <p>When the sub oscillation is selected.</p> <ul style="list-style-type: none"> <li>• Oscillation feedback resistor : Approximately 5MΩ</li> <li>• With Standby mode control</li> </ul> <p>When the GPIO is selected.</p> <ul style="list-style-type: none"> <li>• CMOS level output.</li> <li>• CMOS level hysteresis input</li> <li>• With pull-up resistor control</li> <li>• With standby mode control</li> <li>• Pull-up resistor : Approximately 50kΩ</li> <li>• <math>I_{OH} = -4mA</math>, <math>I_{OL} = 4mA</math></li> </ul>

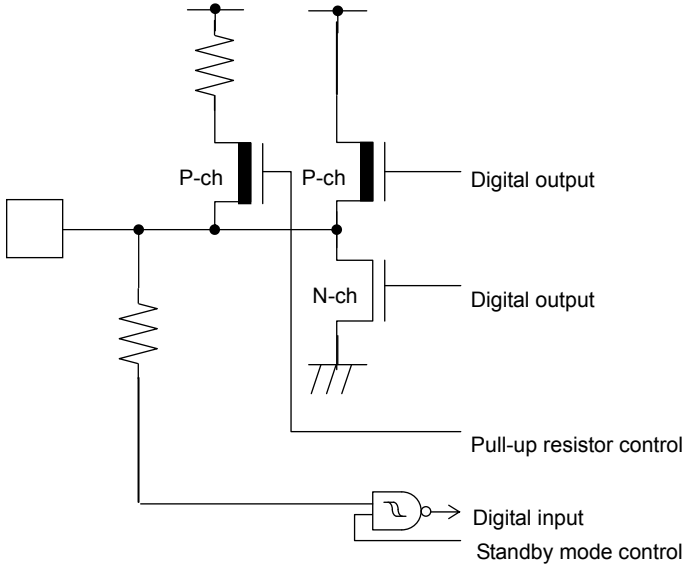
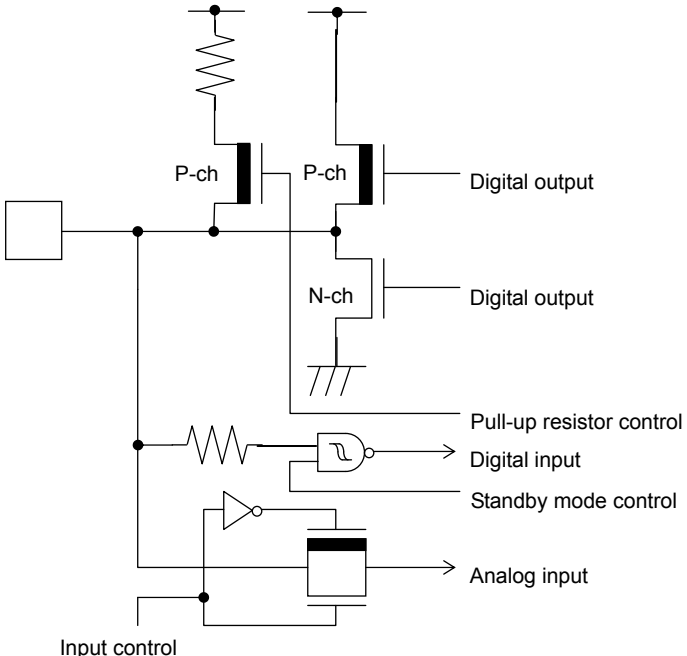
Type	Circuit	Remarks
E	 <p>The diagram for Type E shows a CMOS output stage. It features a P-channel MOSFET (P-ch) and an N-channel MOSFET (N-ch) connected to a common output node. The P-ch MOSFET's gate is connected to a digital input through an AND gate. The N-ch MOSFET's gate is connected to a digital input through an AND gate. A pull-up resistor is connected to the output node. The circuit is controlled by a standby mode control signal through an AND gate. Labels include: Digital output, Digital output, Pull-up resistor control, Digital input, and Standby mode control.</p>	<ul style="list-style-type: none"> <li>• CMOS level output</li> <li>• CMOS level hysteresis input</li> <li>• With pull-up resistor control</li> <li>• With standby mode control</li> <li>• Pull-up resistor : Approximately 50kΩ</li> <li>• <math>I_{OH} = -4\text{mA}</math>, <math>I_{OL} = 4\text{mA}</math></li> </ul>
F	 <p>The diagram for Type F shows a CMOS output stage similar to Type E, but with additional features. It includes an input control signal that can enable or disable the output stage. It also features an analog input through a buffer and a pull-up resistor. Labels include: Digital output, Digital output, Pull-up resistor control, Digital input, Standby mode control, Analog input, and Input control.</p>	<ul style="list-style-type: none"> <li>• CMOS level output</li> <li>• CMOS level hysteresis input</li> <li>• With input control</li> <li>• Analog input</li> <li>• With pull-up resistor control</li> <li>• With standby mode control</li> <li>• Pull-up resistor : Approximately 50kΩ</li> <li>• <math>I_{OH} = -4\text{mA}</math>, <math>I_{OL} = 4\text{mA}</math></li> </ul>

# MB9A110 Series

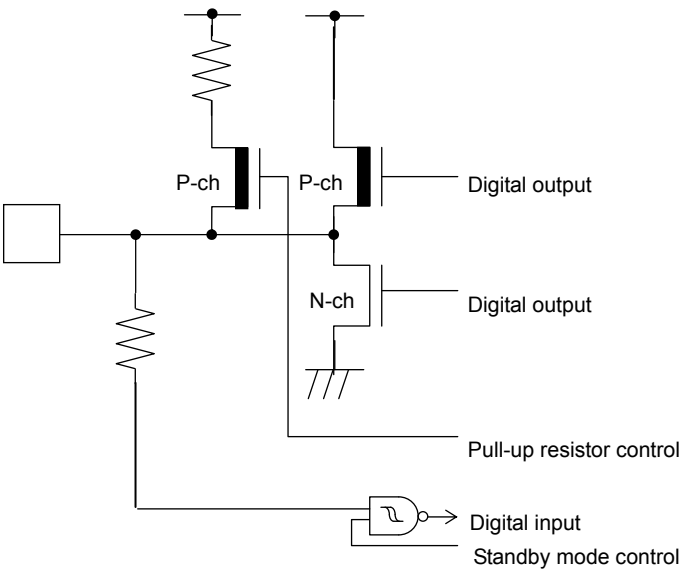
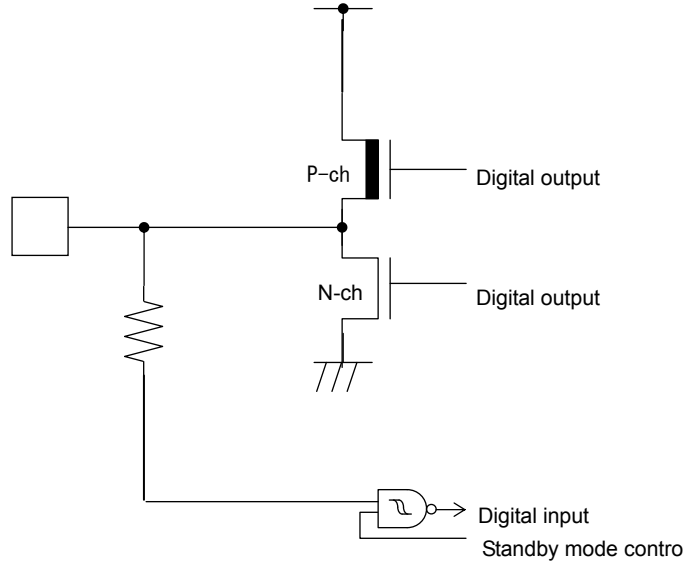
Type	Circuit	Remarks
G	 <p>The diagram for Type G shows a CMOS output stage. A pull-up resistor is connected to the output node. The output node is driven by a P-ch MOSFET (pull-up) and an N-ch MOSFET (pull-down). The gates of both MOSFETs are connected to a digital input signal. A pull-up resistor control signal is connected to the gates of both MOSFETs. A standby mode control signal is connected to an AND gate, which has one input from the digital input signal and another from the pull-up resistor control signal. The output of the AND gate is connected to the gates of both MOSFETs.</p>	<ul style="list-style-type: none"> <li>• CMOS level output</li> <li>• CMOS level hysteresis input</li> <li>• With pull-up resistor control</li> <li>• With standby mode control</li> <li>• Pull-up resistor : Approximately 50kΩ</li> <li>• <math>I_{OH} = -12\text{mA}</math>, <math>I_{OL} = 12\text{mA}</math></li> </ul>
H	 <p>The diagram for Type H shows a CMOS output stage. A pull-up resistor is connected to the output node. The output node is driven by a P-ch MOSFET (pull-up) and an N-ch MOSFET (pull-down). The gates of both MOSFETs are connected to a digital input signal. A pull-up resistor control signal is connected to the gates of both MOSFETs. A standby mode control signal is connected to an AND gate, which has one input from the digital input signal and another from the pull-up resistor control signal. The output of the AND gate is connected to the gates of both MOSFETs.</p>	<ul style="list-style-type: none"> <li>• CMOS level output</li> <li>• CMOS level hysteresis input</li> <li>• With standby mode control</li> <li>• <math>I_{OH} = -20.5\text{mA}</math>, <math>I_{OL} = 18.5\text{mA}</math></li> </ul>

# MB9A110 Series

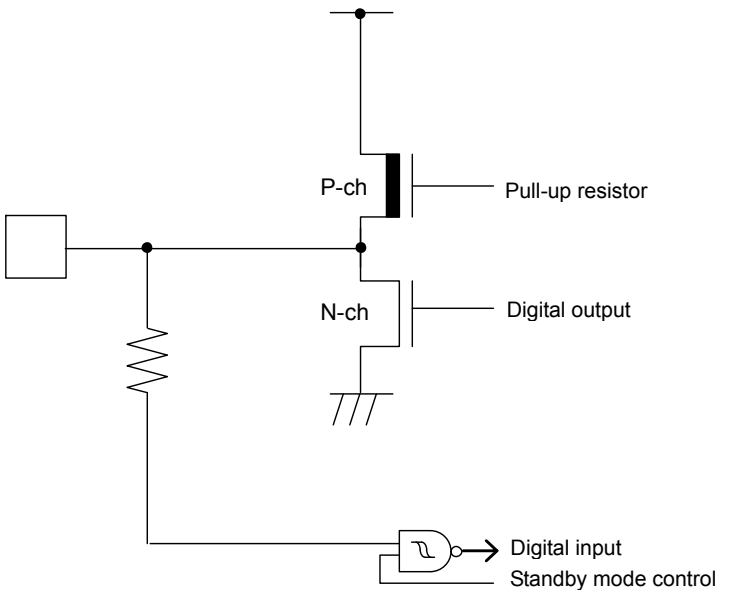
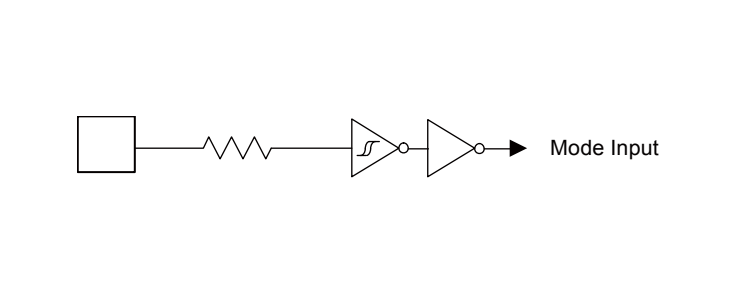
Type	Circuit	Remarks
I	 <p>The diagram shows a CMOS output stage. A pull-up resistor is connected to the output node. The output node is also connected to the gate of a P-channel MOSFET (P-ch) and the gate of an N-channel MOSFET (N-ch). The source of the P-ch MOSFET is connected to VDD, and the source of the N-ch MOSFET is connected to ground. The drain of the P-ch MOSFET is connected to the output node, and the drain of the N-ch MOSFET is also connected to the output node. A digital input is connected to the gates of both MOSFETs. A standby mode control input is connected to the gates of both MOSFETs through a resistor.</p>	<ul style="list-style-type: none"> <li>• CMOS level output</li> <li>• CMOS level hysteresis input</li> <li>• 5V tolerant</li> <li>• With standby mode control</li> <li>• <math>I_{OH} = -4\text{mA}</math>, <math>I_{OL} = 4\text{mA}</math></li> </ul>
J	 <p>The diagram shows a CMOS level hysteresis input circuit. A Mode Input is connected to the input of a Schmitt trigger. The output of the Schmitt trigger is connected to the input of a second Schmitt trigger. The output of the second Schmitt trigger is connected to the Mode Input through a resistor.</p>	<p>CMOS level hysteresis input</p>

## ■ HANDLING PRECAUTIONS

Any semiconductor devices have inherently a certain rate of failure. The possibility of failure is greatly affected by the conditions in which they are used (circuit conditions, environmental conditions, etc.). This page describes precautions that must be observed to minimize the chance of failure and to obtain higher reliability from your FUJITSU SEMICONDUCTOR semiconductor devices.

### 1. Precautions for Product Design

This section describes precautions when designing electronic equipment using semiconductor devices.

#### • Absolute Maximum Ratings

Semiconductor devices can be permanently damaged by application of stress (voltage, current, temperature, etc.) in excess of certain established limits, called absolute maximum ratings. Do not exceed these ratings.

#### • Recommended Operating Conditions

Recommended operating conditions are normal operating ranges for the semiconductor device. All the device's electrical characteristics are warranted when operated within these ranges.

Always use semiconductor devices within the recommended operating conditions. Operation outside these ranges may adversely affect reliability and could result in device failure.

No warranty is made with respect to uses, operating conditions, or combinations not represented on the data sheet. Users considering application outside the listed conditions are advised to contact their sales representative beforehand.

#### • Processing and Protection of Pins

These precautions must be followed when handling the pins which connect semiconductor devices to power supply and input/output functions.

##### (1) Preventing Over-Voltage and Over-Current Conditions

Exposure to voltage or current levels in excess of maximum ratings at any pin is likely to cause deterioration within the device, and in extreme cases leads to permanent damage of the device. Try to prevent such overvoltage or over-current conditions at the design stage.

##### (2) Protection of Output Pins

Shorting of output pins to supply pins or other output pins, or connection to large capacitance can cause large current flows. Such conditions if present for extended periods of time can damage the device.

Therefore, avoid this type of connection.

##### (3) Handling of Unused Input Pins

Unconnected input pins with very high impedance levels can adversely affect stability of operation. Such pins should be connected through an appropriate resistance to a power supply pin or ground pin.

#### • Latch-up

Semiconductor devices are constructed by the formation of P-type and N-type areas on a substrate. When subjected to abnormally high voltages, internal parasitic PNP junctions (called thyristor structures) may be formed, causing large current levels in excess of several hundred mA to flow continuously at the power supply pin. This condition is called latch-up.

**CAUTION:** The occurrence of latch-up not only causes loss of reliability in the semiconductor device, but can cause injury or damage from high heat, smoke or flame. To prevent this from happening, do the following:

(1) Be sure that voltages applied to pins do not exceed the absolute maximum ratings. This should include attention to abnormal noise, surge levels, etc.

(2) Be sure that abnormal current flows do not occur during the power-on sequence.

- **Observance of Safety Regulations and Standards**

Most countries in the world have established standards and regulations regarding safety, protection from electromagnetic interference, etc. Customers are requested to observe applicable regulations and standards in the design of products.

- **Fail-Safe Design**

Any semiconductor devices have inherently a certain rate of failure. You must protect against injury, damage or loss from such failures by incorporating safety design measures into your facility and equipment such as redundancy, fire protection, and prevention of over-current levels and other abnormal operating conditions.

- **Precautions Related to Usage of Devices**

FUJITSU SEMICONDUCTOR semiconductor devices are intended for use in standard applications (computers, office automation and other office equipment, industrial, communications, and measurement equipment, personal or household devices, etc.).

**CAUTION:** Customers considering the use of our products in special applications where failure or abnormal operation may directly affect human lives or cause physical injury or property damage, or where extremely high levels of reliability are demanded (such as aerospace systems, atomic energy controls, sea floor repeaters, vehicle operating controls, medical devices for life support, etc.) are requested to consult with sales representatives before such use. The company will not be responsible for damages arising from such use without prior approval.

## 2. Precautions for Package Mounting

Package mounting may be either lead insertion type or surface mount type. In either case, for heat resistance during soldering, you should only mount under FUJITSU SEMICONDUCTOR's recommended conditions. For detailed information about mount conditions, contact your sales representative.

- **Lead Insertion Type**

Mounting of lead insertion type packages onto printed circuit boards may be done by two methods: direct soldering on the board, or mounting by using a socket.

Direct mounting onto boards normally involves processes for inserting leads into through-holes on the board and using the flow soldering (wave soldering) method of applying liquid solder. In this case, the soldering process usually causes leads to be subjected to thermal stress in excess of the absolute ratings for storage temperature. Mounting processes should conform to FUJITSU SEMICONDUCTOR recommended mounting conditions.

If socket mounting is used, differences in surface treatment of the socket contacts and IC lead surfaces can lead to contact deterioration after long periods. For this reason it is recommended that the surface treatment of socket contacts and IC leads be verified before mounting.

- **Surface Mount Type**

Surface mount packaging has longer and thinner leads than lead-insertion packaging, and therefore leads are more easily deformed or bent. The use of packages with higher pin counts and narrower pin pitch results in increased susceptibility to open connections caused by deformed pins, or shorting due to solder bridges.

You must use appropriate mounting techniques. FUJITSU SEMICONDUCTOR recommends the solder reflow method, and has established a ranking of mounting conditions for each product. Users are advised to mount packages in accordance with FUJITSU SEMICONDUCTOR ranking of recommended conditions.

# MB9A110 Series

- **Lead-Free Packaging**

CAUTION: When ball grid array (BGA) packages with Sn-Ag-Cu balls are mounted using Sn-Pb eutectic soldering, junction strength may be reduced under some conditions of use.

- **Storage of Semiconductor Devices**

Because plastic chip packages are formed from plastic resins, exposure to natural environmental conditions will cause absorption of moisture. During mounting, the application of heat to a package that has absorbed moisture can cause surfaces to peel, reducing moisture resistance and causing packages to crack. To prevent, do the following:

- (1) Avoid exposure to rapid temperature changes, which cause moisture to condense inside the product. Store products in locations where temperature changes are slight.
- (2) Use dry boxes for product storage. Products should be stored below 70% relative humidity, and at temperatures between 5°C and 30°C.  
When you open Dry Package that recommends humidity 40% to 70% relative humidity.
- (3) When necessary, FUJITSU SEMICONDUCTOR packages semiconductor devices in highly moisture-resistant aluminum laminate bags, with a silica gel desiccant. Devices should be sealed in their aluminum laminate bags for storage.
- (4) Avoid storing packages where they are exposed to corrosive gases or high levels of dust.

- **Baking**

Packages that have absorbed moisture may be de-moisturized by baking (heat drying). Follow the FUJITSU SEMICONDUCTOR recommended conditions for baking.

Condition: 125°C/24 h

- **Static Electricity**

Because semiconductor devices are particularly susceptible to damage by static electricity, you must take the following precautions:

- (1) Maintain relative humidity in the working environment between 40% and 70%. Use of an apparatus for ion generation may be needed to remove electricity.
- (2) Electrically ground all conveyors, solder vessels, soldering irons and peripheral equipment.
- (3) Eliminate static body electricity by the use of rings or bracelets connected to ground through high resistance (on the level of 1 MΩ).  
Wearing of conductive clothing and shoes, use of conductive floor mats and other measures to minimize shock loads is recommended.
- (4) Ground all fixtures and instruments, or protect with anti-static measures.
- (5) Avoid the use of styrofoam or other highly static-prone materials for storage of completed board assemblies.



### 3. Precautions for Use Environment

Reliability of semiconductor devices depends on ambient temperature and other conditions as described above.

For reliable performance, do the following:

(1) Humidity

Prolonged use in high humidity can lead to leakage in devices as well as printed circuit boards. If high humidity levels are anticipated, consider anti-humidity processing.

(2) Discharge of Static Electricity

When high-voltage charges exist close to semiconductor devices, discharges can cause abnormal operation. In such cases, use anti-static measures or processing to prevent discharges.

(3) Corrosive Gases, Dust, or Oil

Exposure to corrosive gases or contact with dust or oil may lead to chemical reactions that will adversely affect the device. If you use devices in such conditions, consider ways to prevent such exposure or to protect the devices.

(4) Radiation, Including Cosmic Radiation

Most devices are not designed for environments involving exposure to radiation or cosmic radiation. Users should provide shielding as appropriate.

(5) Smoke, Flame

CAUTION: Plastic molded devices are flammable, and therefore should not be used near combustible substances. If devices begin to smoke or burn, there is danger of the release of toxic gases.

Customers considering the use of FUJITSU SEMICONDUCTOR products in other special environmental conditions should consult with sales representatives.

Please check the latest handling precautions at the following URL.

<http://edevice.fujitsu.com/fj/handling-e.pdf>

## ■ HANDLING DEVICES

### ● Power supply pins

In products with multiple VCC and VSS pins, respective pins at the same potential are interconnected within the device in order to prevent malfunctions such as latch-up. However, all of these pins should be connected externally to the power supply or ground lines in order to reduce electromagnetic emission levels, to prevent abnormal operation of strobe signals caused by the rise in the ground level, and to conform to the total output current rating.

Moreover, connect the current supply source with the VCC and VSS pins of this device at low impedance. It is also advisable that a ceramic capacitor of approximately 0.1  $\mu\text{F}$  be connected as a bypass capacitor between VCC and VSS near this device.

### ● Crystal oscillator circuit

Noise near the X0/X1 and X0A/X1A pins may cause the device to malfunction. Design the printed circuit board so that X0/X1, X0A/X1A pins, the crystal oscillator (or ceramic oscillator), and the bypass capacitor to ground are located as close to the device as possible.

It is strongly recommended that the PC board artwork be designed such that the X0/X1 and X0A/X1A pins are surrounded by ground plane as this is expected to produce stable operation.

### ● Using an external clock

When using an external clock, the clock signal should be input to the X0,X0A pin only and the X1,X1A pin should be kept open.

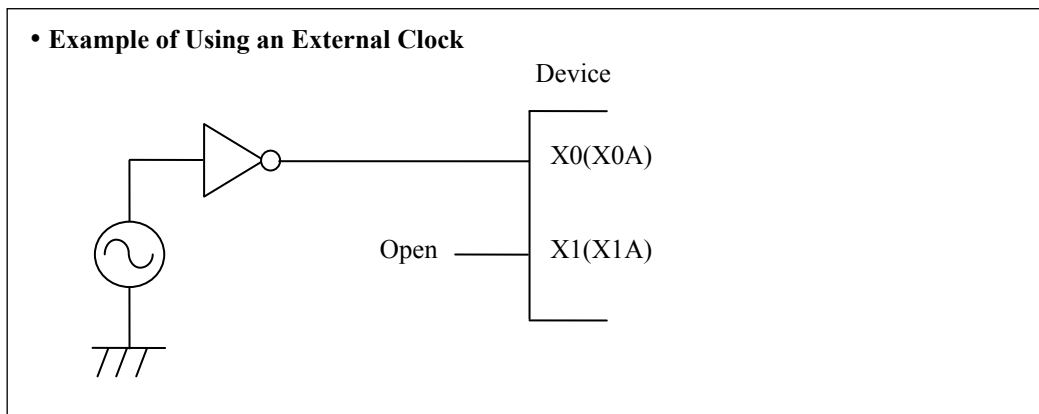

### ● Handling when using Multi function serial pin as I<sup>2</sup>C pin

If it is using multi function serial pin as I<sup>2</sup>C pins, P-ch transistor of digital output is always disable. However, I<sup>2</sup>C pins need to keep the electrical characteristic like other pins and not to connect to external I<sup>2</sup>C bus system with power OFF.

## ● C Pin

As this series includes an internal regulator, always connect a bypass capacitor of approximately 4.7  $\mu\text{F}$  to the C pin for use by the regulator.

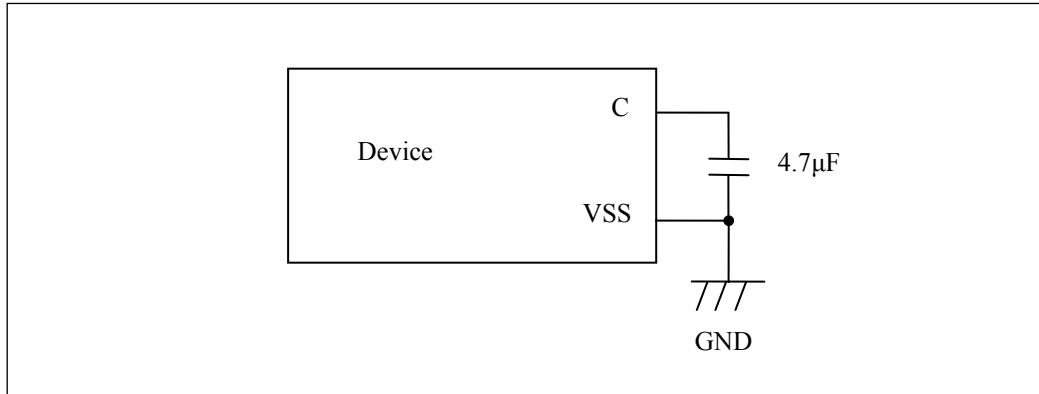

## ● Mode pins (MD0)

Connect the MD pin (MD0) directly to VCC or VSS pins. Design the printed circuit board such that the pull-up/down resistance stays low, as well as the distance between the mode pins and VCC pins or VSS pins is as short as possible and the connection impedance is low, when the pins are pulled-up/down such as for switching the pin level and rewriting the Flash memory data. It is because of preventing the device erroneously switching to test mode due to noise.

## ● Notes on power-on

Turn power on/off in the following order or at the same time.  
If not using the A/D converter, connect AVCC = VCC and AVSS = VSS.

Turning on : VCC → AVCC → AVRH

Turning off : AVRH → AVCC → VCC

## ● Serial Communication

There is a possibility to receive wrong data due to the noise or other causes on the serial communication. Therefore, design a printed circuit board so as to avoid noise. Consider the case of receiving wrong data due to noise, perform error detection such as by applying a checksum of data at the end. If an error is detected, retransmit the data.

## ● Differences in features among the products with different memory sizes and between Flash products and MASK products

The electric characteristics including power consumption, ESD, latch-up, noise characteristics, and oscillation characteristics among the products with different memory sizes and between Flash products and MASK products are different because chip layout and memory structures are different.

If you are switching to use a different product of the same series, please make sure to evaluate the electric characteristics.

# MB9A110 Series

## ■ BLOCK DIAGRAM

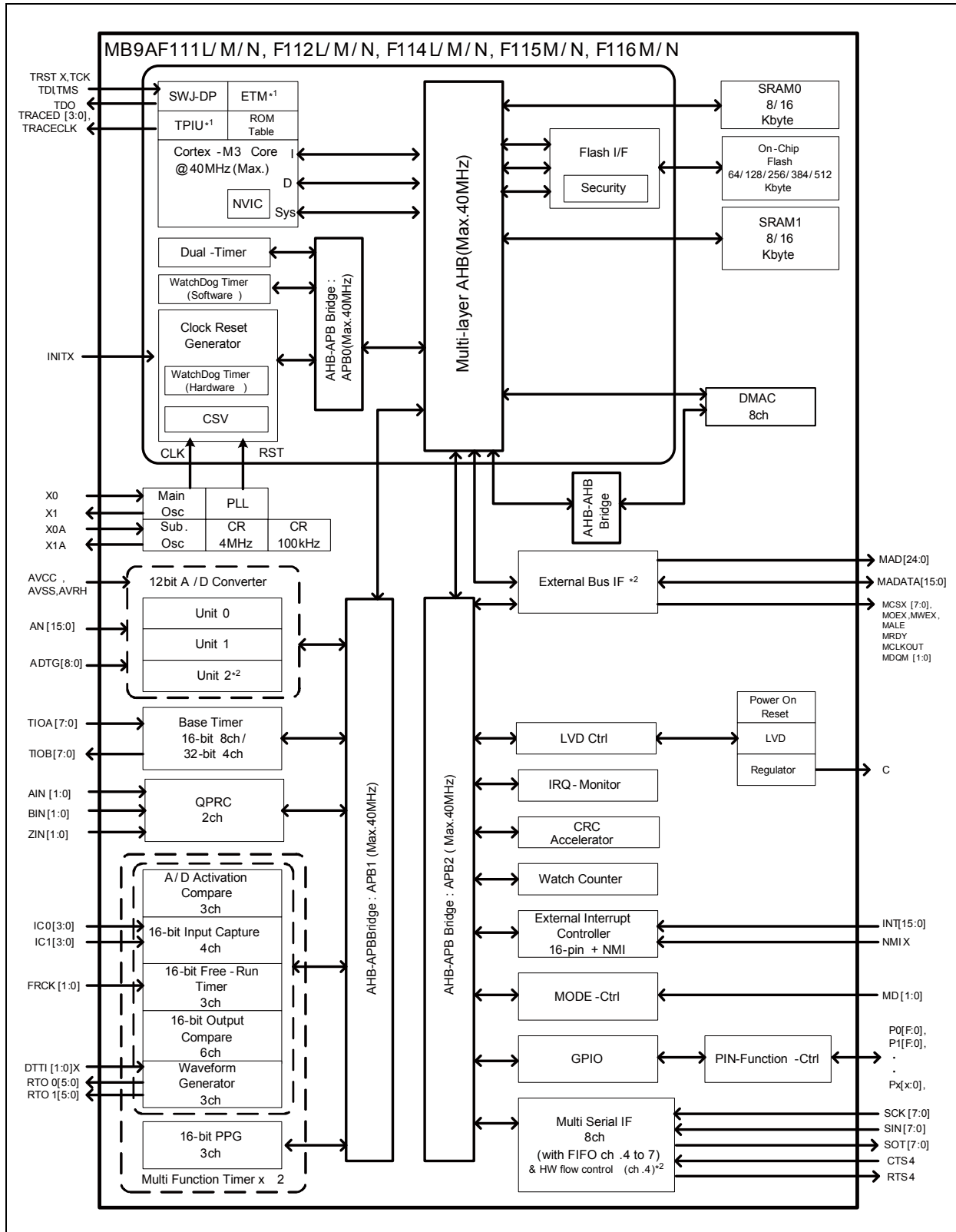

\*1: For the MB9AF111L/M, F112L/M, MB9AF114L/M, MB9AF315M and MB9AF316M, ETM is not available.

\*2: For the MB9AF111L, F112L and MB9AF114L, External Bus Interface and 12-bit A/D Converter (unit 2) are not available. And Multi-function Serial Interface does not support hardware flow control in these products.

# MB9A110 Series

Product device	MB9AF111L/M/N	MB9AF112L/M/N	MB9AF114L/M/N
On-Chip Flash	64Kbyte	128Kbyte	256Kbyte
SRAM0	8Kbyte	8Kbyte	16Kbyte
SRAM1	8Kbyte	8Kbyte	16Kbyte

Product device	MB9AF115M/N	MB9AF116M/N
On-Chip Flash	384Kbyte	512Kbyte
SRAM0	16Kbyte	16Kbyte
SRAM1	16Kbyte	16Kbyte

# MB9A110 Series

## MEMORY MAP

### MB9A110 Series Memory Map (1)

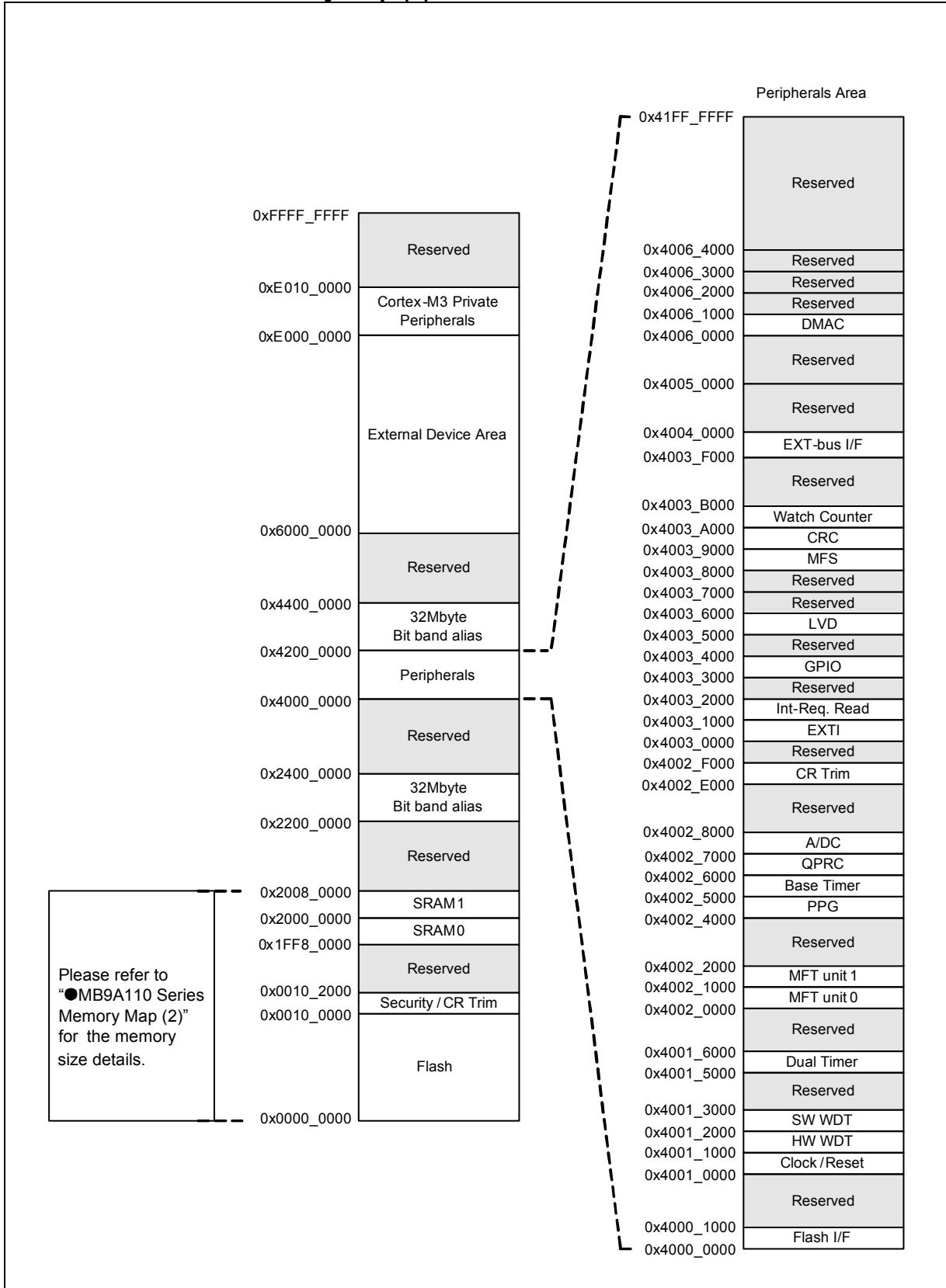

## ● MB9A110 Series Memory Map (2)

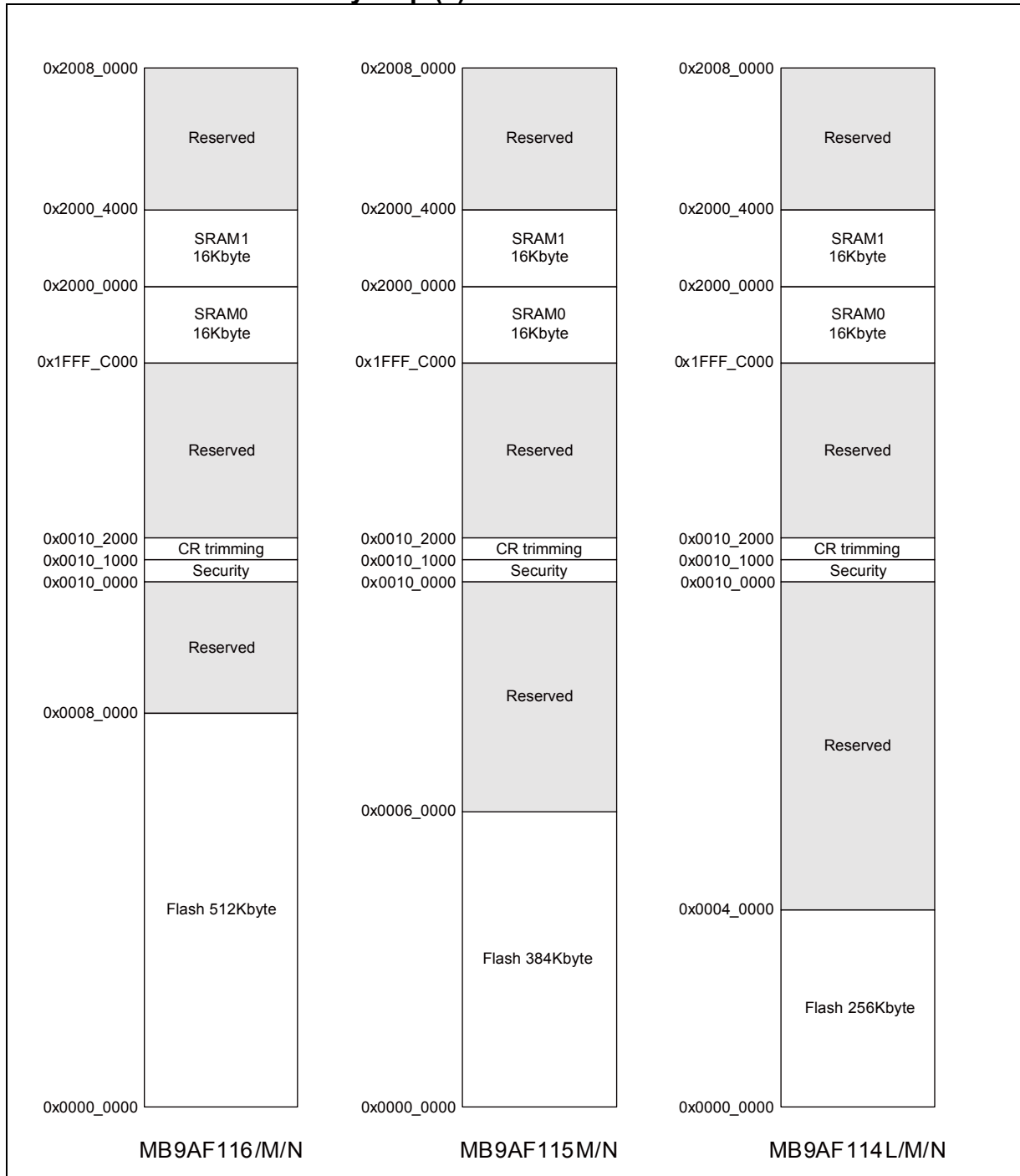

# MB9A110 Series

## ● MB9A110 Series Memory Map (3)

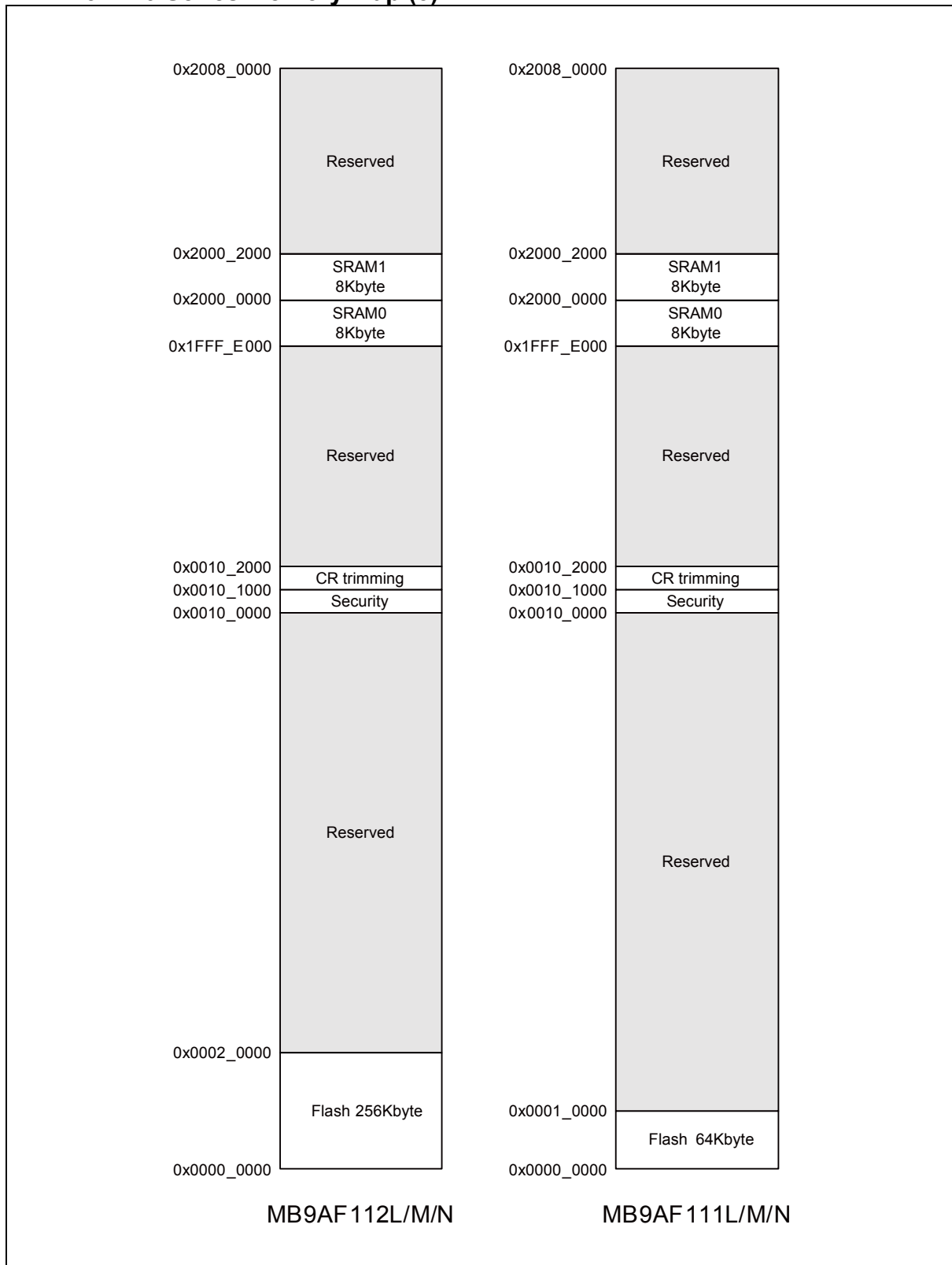



## ● Peripheral Address Map

Start address	End address	Bus	Peripherals	
0x4000_0000 <sub>H</sub>	0x4000_0FFF <sub>H</sub>	AHB	Flash I/F register	
0x4000_1000 <sub>H</sub>	0x4000_FFFF <sub>H</sub>		Reserved	
0x4001_0000 <sub>H</sub>	0x4001_0FFF <sub>H</sub>	APB0	Clock/Reset Control	
0x4001_1000 <sub>H</sub>	0x4001_1FFF <sub>H</sub>		Hardware Watchdog timer	
0x4001_2000 <sub>H</sub>	0x4001_2FFF <sub>H</sub>		Software Watchdog timer	
0x4001_3000 <sub>H</sub>	0x4001_4FFF <sub>H</sub>		Reserved	
0x4001_5000 <sub>H</sub>	0x4001_5FFF <sub>H</sub>		Dual-Timer	
0x4001_6000 <sub>H</sub>	0x4001_FFFF <sub>H</sub>		Reserved	
0x4002_0000 <sub>H</sub>	0x4002_0FFF <sub>H</sub>		APB1	Multi-function timer unit0
0x4002_1000 <sub>H</sub>	0x4002_1FFF <sub>H</sub>			Multi-function timer unit1
0x4002_2000 <sub>H</sub>	0x4002_3FFF <sub>H</sub>	Reserved		
0x4002_4000 <sub>H</sub>	0x4002_4FFF <sub>H</sub>	PPG		
0x4002_5000 <sub>H</sub>	0x4002_5FFF <sub>H</sub>	Base Timer		
0x4002_6000 <sub>H</sub>	0x4002_6FFF <sub>H</sub>	Quadrature Position/Revolution Counter		
0x4002_7000 <sub>H</sub>	0x4002_7FFF <sub>H</sub>	A/D Converter		
0x4002_8000 <sub>H</sub>	0x4002_DFFF <sub>H</sub>	Reserved		
0x4002_E000 <sub>H</sub>	0x4002_EFFF <sub>H</sub>	Internal CR trimming		
0x4002_F000 <sub>H</sub>	0x4002_FFFF <sub>H</sub>	Reserved		
0x4003_0000 <sub>H</sub>	0x4003_0FFF <sub>H</sub>	APB2	External Interrupt Controller	
0x4003_1000 <sub>H</sub>	0x4003_1FFF <sub>H</sub>		Interrupt Request Batch-Read Function	
0x4003_2000 <sub>H</sub>	0x4003_2FFF <sub>H</sub>		Reserved	
0x4003_3000 <sub>H</sub>	0x4003_3FFF <sub>H</sub>		GPIO	
0x4003_4000 <sub>H</sub>	0x4003_4FFF <sub>H</sub>		Reserved	
0x4003_5000 <sub>H</sub>	0x4003_5FFF <sub>H</sub>		Low Voltage Detector	
0x4003_6000 <sub>H</sub>	0x4003_6FFF <sub>H</sub>		Reserved	
0x4003_7000 <sub>H</sub>	0x4003_7FFF <sub>H</sub>		Reserved	
0x4003_8000 <sub>H</sub>	0x4003_8FFF <sub>H</sub>		Multi-function serial Interface	
0x4003_9000 <sub>H</sub>	0x4003_9FFF <sub>H</sub>		CRC	
0x4003_A000 <sub>H</sub>	0x4003_AFFF <sub>H</sub>		Watch Counter	
0x4003_B000 <sub>H</sub>	0x4003_EFFF <sub>H</sub>		Reserved	
0x4003_F000 <sub>H</sub>	0x4003_FFFF <sub>H</sub>		External Memory interface	
0x4004_0000 <sub>H</sub>	0x4004_FFFF <sub>H</sub>		AHB	Reserved
0x4005_0000 <sub>H</sub>	0x4005_FFFF <sub>H</sub>	Reserved		
0x4006_0000 <sub>H</sub>	0x4006_0FFF <sub>H</sub>	DMAC register		
0x4006_1000 <sub>H</sub>	0x4006_1FFF <sub>H</sub>	Reserved		
0x4006_2000 <sub>H</sub>	0x4006_2FFF <sub>H</sub>	Reserved		
0x4006_3000 <sub>H</sub>	0x4006_3FFF <sub>H</sub>	Reserved		
0x4006_4000 <sub>H</sub>	0x41FF_FFFF <sub>H</sub>	Reserved		

## ■ PIN STATUS IN EACH CPU STATE

The terms used for pin status have the following meanings.

- INITX=0  
This is the period when the INITX pin is the "L" level.
- INITX=1  
This is the period when the INITX pin is the "H" level.
- SPL=0  
This is the status that standby pin level setting bit (SPL) in standby mode control register (STB\_CTL) is set to "0".
- SPL=1  
This is the status that standby pin level setting bit (SPL) in standby mode control register (STB\_CTL) is set to "1".
- Input enabled  
Indicates that the input function can be used.
- Internal input fixed at "0"  
This is the status that the input function cannot be used. Internal input is fixed at "L".
- Hi-Z  
Indicates that the output drive transistor is disabled and the pin is put in the Hi-Z state.
- Setting disabled  
Indicates that the setting is disabled.
- Maintain previous state  
Maintains the state that was immediately prior to entering the current mode.  
If a built-in peripheral function is operating, the output follows the peripheral function.  
If the pin is being used as a port, that output is maintained.
- Analog input is enabled  
Indicates that the analog input is enabled.
- Trace output  
Indicates that the trace function can be used.

## ● LIST OF PIN STATUS

Pin status type	Function group	Power-on reset or low voltage detection state	INITX input state	Device internal reset state	Run mode or sleep mode state	Timer mode or sleep mode state	
		Power supply unstable	Power supply stable		Power supply stable	Power supply stable	
		-	INITX=0	INITX=1	INITX=1	INITX=1	
		-	-	-	-	SPL=0	SPL=1
A	GPIO selected	Setting disabled	Setting disabled	Setting disabled	Maintain previous state	Maintain previous state	Output Hi-Z/ Internal input fixed at "0"
	Main crystal oscillator input pin	Input enabled	Input enabled	Input enabled	Input enabled	Input enabled	Input enabled
B	GPIO selected	Setting disabled	Setting disabled	Setting disabled	Maintain previous state	Maintain previous state	Output Hi-Z/ Internal input fixed at "0"
	Main crystal oscillator output pin	Hi-Z/ Internal input fixed at "0"/ or Input enable	Hi-Z/ Internal input fixed at "0"	Hi-Z/ Internal input fixed at "0"	Maintain previous state	Maintain previous state/ Hi-Z at oscillation stop* <sup>1</sup> / Internal input fixed at "0"	Maintain previous state/ Hi-Z at oscillation stop* <sup>1</sup> / Internal input fixed at "0"
C	INITX input pin	Pull-up/ Input enabled	Pull-up/ Input enabled	Pull-up/ Input enabled	Pull-up/ Input enabled	Pull-up/ Input enabled	Pull-up/ Input enabled
D	Mode input pin	Input enabled	Input enabled	Input enabled	Input enabled	Input enabled	Input enabled
E	JTAG selected	Hi-Z	Pull-up/ Input enabled	Pull-up/ Input enabled	Maintain previous state	Maintain previous state	Maintain previous state
	GPIO selected	Setting disabled	Setting disabled	Setting disabled			Output Hi-Z/ Internal input fixed at "0"
F	Trace selected	Setting disabled	Setting disabled	Setting disabled	Maintain previous state	Maintain previous state	Trace output
	External interrupt enabled selected						Maintain previous state
	GPIO selected, or other than above resource selected	Hi-Z	Hi-Z/ Input enabled	Hi-Z/ Input enabled			Hi-Z/ Internal input fixed at "0"

# MB9A110 Series

Pin status type	Function group	Power-on reset or low voltage detection state	INITX input state	Device internal reset state	Run mode or sleep mode state	Timer mode or sleep mode state	
		Power supply unstable	Power supply stable		Power supply stable	Power supply stable	
		-	INITX=0	INITX=1	INITX=1	INITX=1	
		-	-	-	-	SPL=0	SPL=1
G	Trace selected	Setting disabled	Setting disabled	Setting disabled	Maintain previous state	Maintain previous state	Trace output
	GPIO selected, or other than above resource selected	Hi-Z	Hi-Z/ Input enabled	Hi-Z/ Input enabled			Hi-Z/ Internal input fixed at "0"
H	External interrupt enabled selected	Setting disabled	Setting disabled	Setting disabled	Maintain previous state	Maintain previous state	Maintain previous state
	GPIO selected, or other than above resource selected	Hi-Z	Hi-Z/ Input enabled	Hi-Z/ Input enabled			Hi-Z/ Internal input fixed at "0"
I	GPIO selected, resource selected	Hi-Z	Hi-Z/ Input enabled	Hi-Z/ Input enabled	Maintain previous state	Maintain previous state	Output Hi-Z/ Internal input fixed at "0"
J	NMIX selected	Setting disabled	Setting disabled	Setting disabled	Maintain previous state	Maintain previous state	Maintain previous state
	GPIO selected, or other than above resource selected	Hi-Z	Hi-Z/ Input enabled	Hi-Z/ Input enabled			Hi-Z/ Internal input fixed at "0"

# MB9A110 Series

Pin status type	Function group	Power-on reset or low voltage detection state	INITX input state	Device internal reset state	Run mode or sleep mode state	Timer mode or sleep mode state	
		Power supply unstable	Power supply stable		Power supply stable	Power supply stable	
		-	INITX=0	INITX=1	INITX=1	INITX=1	
		-	-	-	-	SPL=0	SPL=1
K	Analog input selected	Hi-Z	Hi-Z/ Internal input fixed at "0"/ Analog input enabled	Hi-Z/ Internal input fixed at "0"/ Analog input enabled	Hi-Z/ Internal input fixed at "0"/ Analog input enabled	Hi-Z/ Internal input fixed at "0"/ Analog input enabled	Hi-Z/ Internal input fixed at "0"/ Analog input enabled
	GPIO selected, or other than above resource selected	Setting disabled	Setting disabled	Setting disabled	Maintain previous state	Maintain previous state	Hi-Z/ Internal input fixed at "0"
L	External interrupt enabled selected	Setting disabled	Setting disabled	Setting disabled	Maintain previous state	Maintain previous state	Maintain previous state
	Analog input selected	Hi-Z	Hi-Z/ Internal input fixed at "0"/ Analog input enabled	Hi-Z/ Internal input fixed at "0"/ Analog input enabled	Hi-Z/ Internal input fixed at "0"/ Analog input enabled	Hi-Z/ Internal input fixed at "0"/ Analog input enabled	Hi-Z/ Internal input fixed at "0"/ Analog input enabled
	GPIO selected, or other than above resource selected	Setting disabled	Setting disabled	Setting disabled	Maintain previous state	Maintain previous state	Hi-Z/ Internal input fixed at "0"
M	GPIO selected	Setting disabled	Setting disabled	Setting disabled	Maintain previous state	Maintain previous state	Output Hi-Z/ Internal input fixed at "0"
	Sub crystal oscillator input pin	Input enabled	Input enabled	Input enabled	Input enabled	Input enabled	Input enabled

# MB9A110 Series

Pin status type	Function group	Power-on reset or low voltage detection state	INITX input state	Device internal reset state	Run mode or sleep mode state	Timer mode or sleep mode state	
		Power supply unstable	Power supply stable		Power supply stable	Power supply stable	
		-	INITX=0	INITX=1	INITX=1	INITX=1	
		-	-	-	-	SPL=0	SPL=1
N	GPIO selected	Setting disabled	Setting disabled	Setting disabled	Maintain previous state	Maintain previous state	Output Hi-Z/ Internal input fixed at "0"
	Sub crystal oscillator output pin	Hi-Z/ Internal input fixed at "0"/ or Input enable	Hi-Z/ Internal input fixed at "0"	Hi-Z/ Internal input fixed at "0"	Maintain previous state	Maintain previous state/ Hi-Z at oscillation stop*2/ Internal input fixed at "0"	Maintain previous state/ Hi-Z at oscillation stop*2/ Internal input fixed at "0"
O	GPIO pin	Hi-Z	Hi-Z/ Input enabled	Hi-Z/ Input enabled	Maintain previous state	Maintain previous state	Output Hi-Z/ Internal input fixed at "0"
P	Mode input pin	Input enabled	Input enabled	Input enabled	Input enabled	Input enabled	Input enabled
	GPIO selected	Setting disabled	Setting disabled	Setting disabled	Maintain previous state	Maintain previous state	Output Hi-Z/ Input enabled

\*1 : Oscillation is stopped at sub timer mode, low speed CR timer mode, and stop mode.

\*2 : Oscillation is stopped at stop mode.

## ■ ELECTRICAL CHARACTERISTICS

### 1. Absolute Maximum Ratings

Parameter	Symbol	Rating		Unit	Remarks
		Min	Max		
Power supply voltage* <sup>1</sup> , * <sup>2</sup>	V <sub>CC</sub>	V <sub>SS</sub> - 0.5	V <sub>SS</sub> + 6.5	V	
Analog power supply voltage* <sup>1</sup> , * <sup>3</sup>	AV <sub>CC</sub>	V <sub>SS</sub> - 0.5	V <sub>SS</sub> + 6.5	V	
Analog reference voltage* <sup>1</sup> , * <sup>3</sup>	AV <sub>RH</sub>	V <sub>SS</sub> - 0.5	V <sub>SS</sub> + 6.5	V	
Input voltage* <sup>1</sup>	V <sub>I</sub>	V <sub>SS</sub> - 0.5	V <sub>CC</sub> + 0.5 (≤ 6.5V)	V	
		V <sub>SS</sub> - 0.5	V <sub>SS</sub> + 6.5	V	5V tolerant
Analog pin input voltage* <sup>1</sup>	V <sub>IA</sub>	V <sub>SS</sub> - 0.5	AV <sub>CC</sub> + 0.5 (≤ 6.5V)	V	
Output voltage* <sup>1</sup>	V <sub>O</sub>	V <sub>SS</sub> - 0.5	V <sub>CC</sub> + 0.5 (≤ 6.5V)	V	
"L" level maximum output current* <sup>4</sup>	I <sub>OL</sub>	-	10	mA	4mA type
			20	mA	12mA type
"L" level average output current* <sup>5</sup>	I <sub>OLAV</sub>	-	4	mA	4mA type
			12	mA	12mA type
"L" level total maximum output current	∑I <sub>OL</sub>	-	100	mA	
"L" level total average output current* <sup>6</sup>	∑I <sub>OLAV</sub>	-	50	mA	
"H" level maximum output current* <sup>4</sup>	I <sub>OH</sub>	-	- 10	mA	4mA type
			- 20	mA	12mA type
"H" level average output current* <sup>5</sup>	I <sub>OHAV</sub>	-	- 4	mA	4mA type
			- 12	mA	12mA type
"H" level total maximum output current	∑I <sub>OH</sub>	-	- 100	mA	
"H" level total average output current* <sup>6</sup>	∑I <sub>OHAV</sub>	-	- 50	mA	
Power consumption	P <sub>D</sub>	-	300	mW	
Storage temperature	T <sub>STG</sub>	- 55	+ 150	°C	

\*1 : These parameters are based on the condition that V<sub>SS</sub> = AV<sub>SS</sub> = 0.0V.

\*2 : V<sub>CC</sub> must not drop below V<sub>SS</sub> - 0.5V.

\*3 : Be careful not to exceed V<sub>CC</sub> + 0.5 V, for example, when the power is turned on.

\*4 : The maximum output current is the peak value for a single pin.

\*5 : The average output is the average current for a single pin over a period of 100 ms.

\*6 : The total average output current is the average current for all pins over a period of 100 ms.

### <WARNING>

Semiconductor devices can be permanently damaged by application of stress (voltage, current, temperature, etc.) in excess of absolute maximum ratings. Do not exceed these ratings.

# MB9A110 Series

## 2. Recommended Operating Conditions

(V<sub>SS</sub> = AV<sub>SS</sub> = 0.0V)

Parameter	Symbol	Conditions	Value		Unit	Remarks	
			Min	Max			
Power supply voltage	V <sub>CC</sub>	-	2.7	5.5	V		
Analog power supply voltage	AV <sub>CC</sub>	-	2.7	5.5	V	AV <sub>CC</sub> = V <sub>CC</sub>	
Analog reference voltage	AV <sub>RH</sub>	-	AV <sub>SS</sub>	AV <sub>CC</sub>	V		
Operating temperature	FPT-100P-M20 FPT-100P-M23 FPT-80P-M21 FPT-80P-M37 FPT-64P-M24 FPT-64P-M38 FPT-64P-M23 FPT-64P-M39 BGA-112P-M04	T <sub>a</sub>	-	- 40	+ 105	°C	
	FPT-100P-M06	T <sub>a</sub>	When mounted on four-layer PCB	- 40	+ 105	°C	
			When mounted on double-sided single-layer PCB	- 40	+ 105	°C	I <sub>CC</sub> ≤ 35mA
				- 40	+ 85	°C	I <sub>CC</sub> > 35mA

### <WARNING>

The recommended operating conditions are required in order to ensure the normal operation of the semiconductor device. All of the device's electrical characteristics are warranted when the device is operated within these ranges.

Always use semiconductor devices within their recommended operating condition ranges. Operation outside these ranges may adversely affect reliability and could result in device failure. No warranty is made with respect to uses, operating conditions, or combinations not represented on the data sheet. Users considering application outside the listed conditions are advised to contact their representatives beforehand.



# MB9A110 Series

## ● DC Characteristics

### 1. Current rating

(Vcc = AVcc = 2.7V to 5.5V, Vss = AVss = 0V, Ta = - 40°C to + 105°C)

Parameter	Symbol	Pin name	Conditions	Value			Unit	Remarks
				Min	Typ	Max		
Power supply current	Icc	Vcc	Normal operation (PLL) Vcc=5.5V	-	32	41	mA	CPU : 40MHz, Peripheral : 40MHz, Flash 0Wait FRWTR.RWT = 00 FSYNDN.SD = 000 *1
				-	21	28	mA	CPU : 40MHz, Peripheral : 40MHz, Flash 3Wait FRWTR.RWT = 00 FSYNDN.SD = 011 *1
			Normal operation (built-in high-speed CR) Vcc=5.5V	-	3.9	7.7	mA	CPU/ Peripheral : 4MHz *1, *2 Flash 0Wait FRWTR.RWT = 00 FSYNDN.SD = 000
			Normal operation (sub oscillation) Vcc=5.5V	-	0.15	3.2	mA	CPU/ Peripheral : 32kHz Flash 0Wait FRWTR.RWT = 00 FSYNDN.SD = 000 *1
			Normal operation (built-in low-speed CR) Vcc=5.5V	-	0.2	3.3	mA	CPU/ Peripheral : 100kHz Flash 0Wait FRWTR.RWT = 00 FSYNDN.SD = 000 *1
	Iccs	Vcc	SLEEP operation (PLL) Vcc=5.5V	-	10	15	mA	Peripheral : 40MHz *1
			SLEEP operation (built-in high-speed CR) Vcc=5.5V	-	1.2	4.4	mA	Peripheral : 4MHz *1, *2
			SLEEP operation (sub oscillation) Vcc=5.5V	-	0.1	3.1	mA	Peripheral : 32kHz *1
			SLEEP operation (built in low-speed CR) Vcc=5.5V	-	0.1	3.1	mA	Peripheral : 100kHz *1

# MB9A110 Series

Parameter	Symbol	Pin name	Conditions	Value			Unit	Remarks
				Min	Typ	Max		
Power supply current	I <sub>CCH</sub>	V <sub>CC</sub>	STOP mode V <sub>CC</sub> =5.5V	-	35	200	μA	Ta = + 25°C, When LVD is off *1
				-	-	3	mA	Ta = + 105°C, When LVD is off *1
	I <sub>CCT</sub>		TIMER mode (sub oscillation) V <sub>CC</sub> =5.5V	-	60	230	μA	Ta = + 25°C, When LVD is off *1
				-	-	3.1	mA	Ta = + 105°C, When LVD is off *1
Low voltage detection circuit (LVD) power supply current	I <sub>CCLVD</sub>		At operation V <sub>CC</sub> =5.5V	-	4	7	μA	for occurrence of interrupt

\*1: When all ports are fixed.

\*2: When setting it to 4MHz by trimming.

## 2. Pin Characteristics

(V<sub>CC</sub> = AV<sub>CC</sub> = 2.7V to 5.5V, V<sub>SS</sub> = AV<sub>SS</sub> = 0V, T<sub>a</sub> = - 40°C to + 105°C)

Parameter	Symbol	Pin name	Conditions	Value			Unit	Remarks
				Min	Typ	Max		
"H" level input voltage (hysteresis input)	V <sub>IHS</sub>	CMOS hysteresis input pin, MD0,1	-	V <sub>CC</sub> × 0.8	-	V <sub>CC</sub> + 0.3	V	
		5V tolerant I/O	-	V <sub>CC</sub> × 0.8	-	V <sub>SS</sub> + 5.5	V	
"L" level input voltage (hysteresis input)	V <sub>ILS</sub>	CMOS hysteresis input pin, MD0,1	-	V <sub>SS</sub> - 0.3	-	V <sub>CC</sub> × 0.2	V	
"H" level output voltage	V <sub>OH</sub>	4mA type	V <sub>CC</sub> ≥ 4.5 V I <sub>OH</sub> = - 4mA	V <sub>CC</sub> - 0.5	-	V <sub>CC</sub>	V	
			V <sub>CC</sub> < 4.5 V I <sub>OH</sub> = - 2mA					
		12mA type	V <sub>CC</sub> ≥ 4.5 V I <sub>OH</sub> = - 12mA	V <sub>CC</sub> - 0.5	-	V <sub>CC</sub>	V	
			V <sub>CC</sub> < 4.5 V I <sub>OH</sub> = - 8mA					
		P80,P81	V <sub>CC</sub> ≥ 4.5 V I <sub>OH</sub> = - 20.5mA	V <sub>CC</sub> - 0.4	-	V <sub>CC</sub>	V	
			V <sub>CC</sub> < 4.5 V I <sub>OH</sub> = - 13.0mA					
"L" level output voltage	V <sub>OL</sub>	4mA type	V <sub>CC</sub> ≥ 4.5 V I <sub>OL</sub> = 4mA	V <sub>SS</sub>	-	0.4	V	
			V <sub>CC</sub> < 4.5 V I <sub>OL</sub> = 2mA					
		12mA type	V <sub>CC</sub> ≥ 4.5 V I <sub>OL</sub> = 12mA	V <sub>SS</sub>	-	0.4	V	
			V <sub>CC</sub> < 4.5 V I <sub>OL</sub> = 8mA					
		P80,P81	V <sub>CC</sub> ≥ 4.5 V I <sub>OL</sub> = 18.5mA	V <sub>SS</sub>	-	0.4	V	
			V <sub>CC</sub> < 4.5 V I <sub>OL</sub> = 10.5mA					
Input leak current	I <sub>IL</sub>	-	-	- 5	-	5	μA	
Pull-up resistance value	R <sub>PU</sub>	Pull-up pin	V <sub>CC</sub> ≥ 4.5 V	25	50	100	kΩ	
			V <sub>CC</sub> < 4.5 V	80	80	200		
Input capacitance	C <sub>IN</sub>	Other than V <sub>CC</sub> , V <sub>SS</sub> , AV <sub>CC</sub> , AV <sub>SS</sub> , AVRH	-	-	5	15	pF	

# MB9A110 Series

## ● AC Characteristics

### (1) Main Clock Input Characteristics

(V<sub>CC</sub> = 2.7V to 5.5V, V<sub>SS</sub> = 0V, Ta = -40°C to +105°C)

Parameter	Symbol	Pin name	Conditions	Value		Unit	Remarks
				Min	Max		
Input frequency	F <sub>CH</sub>	X0 X1	V <sub>CC</sub> ≥ 4.5V	4	48	MHz	When crystal oscillator is connected
			V <sub>CC</sub> < 4.5V	4	20		
			V <sub>CC</sub> ≥ 4.5V	4	48	MHz	When using external clock
			V <sub>CC</sub> < 4.5V	4	20		
Input clock cycle	t <sub>CY<sub>LH</sub></sub>		V <sub>CC</sub> ≥ 4.5V	20.83	250	ns	When using external clock
			V <sub>CC</sub> < 4.5V	50	250		
Input clock pulse width	-		P <sub>WH</sub> /t <sub>CY<sub>LH</sub></sub> P <sub>WL</sub> /t <sub>CY<sub>LH</sub></sub>	45	55	%	When using external clock
Input clock rise time and fall time	t <sub>CF</sub> t <sub>CR</sub>		-	-	5	ns	When using external clock
Internal operating clock frequency	F <sub>CC</sub>	-	-	-	40	MHz	Base clock (HCLK/FCLK)
	F <sub>CP0</sub>	-	-	-	40	MHz	APB0 bus clock (PCLK0)
	F <sub>CP1</sub>	-	-	-	40	MHz	APB1 bus clock (PCLK1)
	F <sub>CP2</sub>	-	-	-	40	MHz	APB2 bus clock (PCLK2)
Internal operating clock cycle time	t <sub>CY<sub>CC</sub></sub>	-	-	25	-	ns	Base clock (HCLK/FCLK)
	t <sub>CY<sub>CP0</sub></sub>	-	-	25	-	ns	APB0 bus clock (PCLK0)
	t <sub>CY<sub>CP1</sub></sub>	-	-	25	-	ns	APB1 bus clock (PCLK1)
	t <sub>CY<sub>CP2</sub></sub>	-	-	25	-	ns	APB2 bus clock (PCLK2)

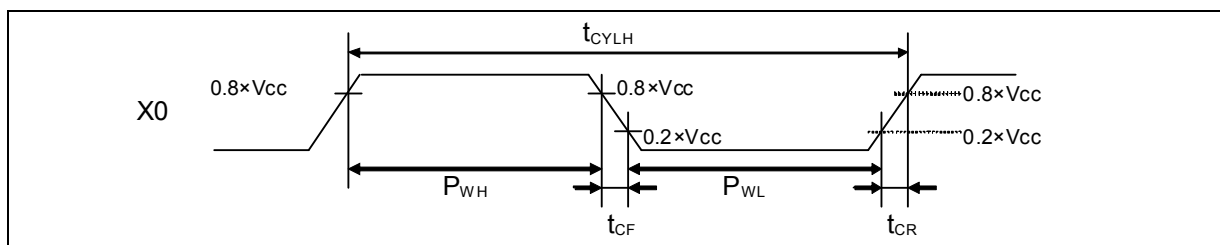

Note: Please see the block diagram to refer the APB bus which peripherals connected.

Please see "Chapter: Clock" in "FM3 MB9Axxx / MB9Bxxx Series PERIPHERAL MANUAL" to refer the detail of internal operating clock.

## (2) Sub Clock Input Characteristics

(V<sub>CC</sub> = 2.7V to 5.5V, V<sub>SS</sub> = 0V, T<sub>a</sub> = - 40°C to + 105°C)

Parameter	Symbol	Pin name	Conditions	Value			Unit	Remarks
				Min	Typ	Max		
Input frequency	F <sub>CL</sub>	X0A X1A	-	-	32.768	-	kHz	When crystal oscillator is connected
			-	32	-	100		kHz
Input clock cycle	t <sub>CYLL</sub>		-	10	-	31.25	μs	When using external clock
Input clock pulse width	-		P <sub>WH</sub> /t <sub>CYLL</sub> P <sub>WL</sub> /t <sub>CYLL</sub>	45	-	55	%	When using external clock

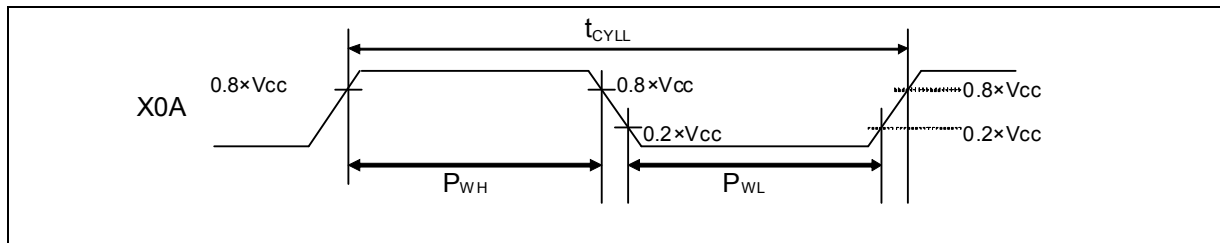

## (3) Built-in CR Oscillation Characteristics

- Built-in high-speed CR

(V<sub>CC</sub> = 2.7V to 5.5V, V<sub>SS</sub> = 0V, T<sub>a</sub> = - 40°C to + 105°C)

Parameter	Symbol	Conditions	Value			Unit	Remarks
			Min	Typ	Max		
Clock frequency	F <sub>CRH</sub>	T <sub>a</sub> = + 25°C	3.96	4	4.04	MHz	When trimming*
		T <sub>a</sub> = 0°C to + 70°C	3.84	4	4.16		
		T <sub>a</sub> = - 40°C to + 105°C	3.8	4	4.2		
		T <sub>a</sub> = - 40°C to + 105°C	3	4	5		When not trimming

\*: In the case of using the values in CR trimming area of Flashmemory at shipment for frequency trimming.

- Built-in low-speed CR

(V<sub>CC</sub> = 2.7V to 5.5V, V<sub>SS</sub> = 0V, T<sub>a</sub> = - 40°C to + 105°C)

Parameter	Symbol	Conditions	Value			Unit	Remarks
			Min	Typ	Max		
Clock frequency	F <sub>CRL</sub>	-	50	100	150	kHz	

# MB9A110 Series

## (4-1) Operating Conditions of Main PLL (In the case of using main clock for input clock of PLL)

(V<sub>CC</sub> = 2.7V to 5.5V, V<sub>SS</sub> = 0V, T<sub>a</sub> = - 40°C to + 105°C)

Parameter	Symbol	Value			Unit	Remarks
		Min	Typ	Max		
PLL oscillation stabilization wait time (LOCK UP time)*	t <sub>LOCK</sub>	100	-	-	μs	
PLL input clock frequency	f <sub>PLL</sub>	4	-	16	MHz	
PLL multiple rate	-	13	-	75	multiple	
PLL macro oscillation clock frequency	f <sub>PLLO</sub>	200	-	300	MHz	

\*: Time from when the PLL starts operating until the oscillation stabilizes.

## (4-2) Operating Conditions of Main PLL (In the case of using built-in high speed CR)

(V<sub>CC</sub> = 2.7V to 5.5V, V<sub>SS</sub> = 0V, T<sub>a</sub> = - 40°C to + 105°C)

Parameter	Symbol	Value			Unit	Remarks
		Min	Typ	Max		
PLL oscillation stabilization wait time (LOCK UP time)*	t <sub>LOCK</sub>	100	-	-	μs	
PLL input clock frequency	f <sub>PLL</sub>	3.8	4	4.2	MHz	
PLL multiple rate	-	50	-	71	multiple	
PLL macro oscillation clock frequency	f <sub>PLLO</sub>	190	-	300	MHz	

\*: Time from when the PLL starts operating until the oscillation stabilizes.

Note: It needs to input to PLL by built-in CR trimming frequency.

## (5) Reset Input Characteristics

(V<sub>CC</sub> = 2.7V to 5.5V, V<sub>SS</sub> = 0V, T<sub>a</sub> = - 40°C to + 105°C)

Parameter	Symbol	Pin name	Conditions	Value		Unit	Remarks
				Min	Max		
Reset input time	t <sub>INITX</sub>	INITX	-	500	-	ns	

## (6) Power-on Reset Timing

(V<sub>CC</sub> = 2.7V to 5.5V, V<sub>SS</sub> = 0V, T<sub>a</sub> = - 40°C to + 105°C)

Parameter	Symbol	Pin name	Value		Unit	Remarks
			Min	Max		
Power supply rising time	Tr	V <sub>CC</sub>	0	-	ms	
Power supply shut down time	Toff		1	-	ms	

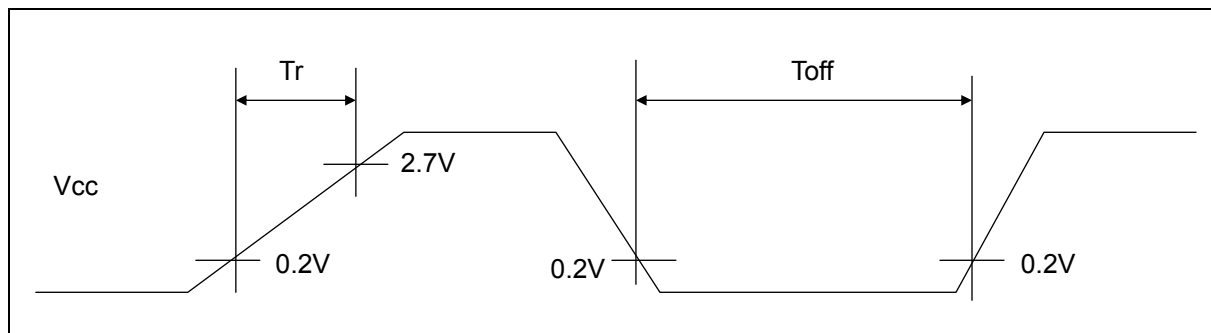

## (7) External Bus Timing

- External bus clock output Characteristics

( $V_{CC} = 2.7V$  to  $5.5V$ ,  $V_{SS} = 0V$ ,  $T_a = -40^{\circ}C$  to  $+105^{\circ}C$ )

Parameter	Symbol	Pin name	Conditions	Value		Unit
				Min	Max	
Output frequency	$t_{CYCLE}$	MCLKOUT	$V_{CC} \geq 4.5 V$	-	40	MHz
			$V_{CC} < 4.5 V$	-	32	MHz
Minimum clock cycle time	-		$V_{CC} \geq 4.5 V$	25	-	ns
			$V_{CC} < 4.5 V$	31.25	-	ns

Note: External bus clock output is divided clock of HCLK. Please see "Chapter: External Bus Interface" in "FM3 MB9Axxx / MB9Bxxx Series PERIPHERAL MANUAL" to refer the detail of setting.

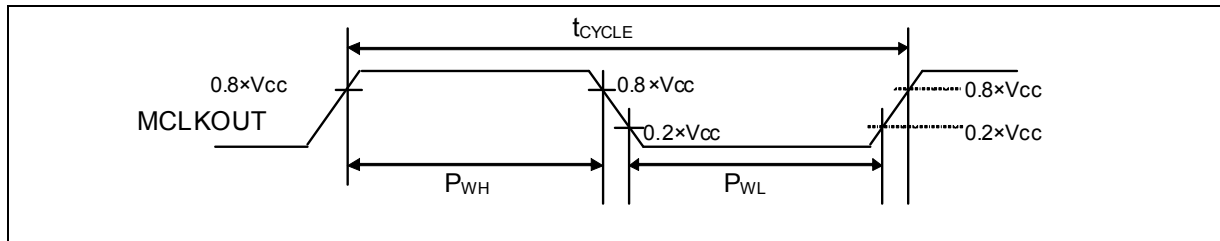

- External bus signal input/output Characteristics

( $V_{CC} = 2.7V$  to  $5.5V$ ,  $V_{SS} = 0V$ ,  $T_a = -40^{\circ}C$  to  $+105^{\circ}C$ )

Parameter	Symbol	Conditions	Value	Unit	Remarks
Signal input characteristics	$V_{IH}$	-	$0.8 \times V_{CC}$	V	
	$V_{IL}$		$0.2 \times V_{CC}$	V	
Signal output characteristics	$V_{OH}$		$0.8 \times V_{CC}$	V	
	$V_{OL}$		$0.2 \times V_{CC}$	V	

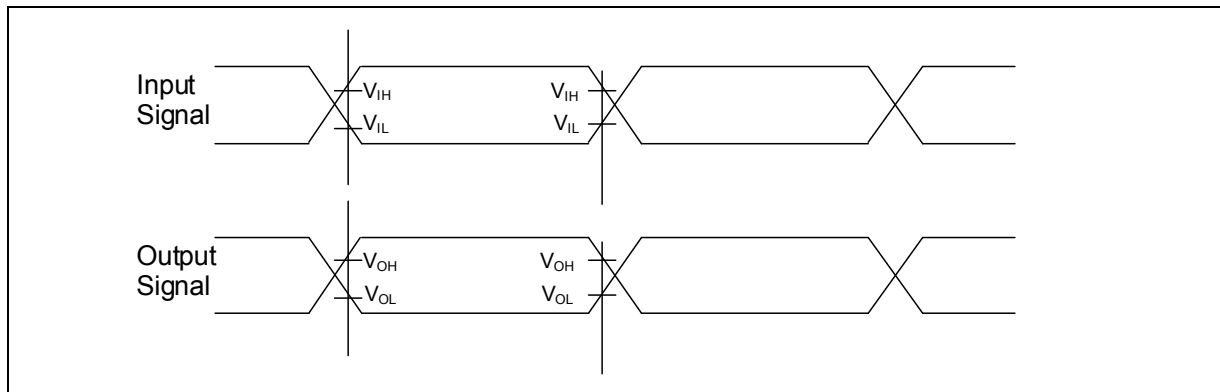

# MB9A110 Series

• Separate Bus Access Asynchronous SRAM Mode

( $V_{cc} = 2.7V$  to  $5.5V$ ,  $V_{ss} = 0V$ ,  $T_a = -40^{\circ}C$  to  $+105^{\circ}C$ )

Parameter	Symbol	Pin name	Conditions	Value		Unit
				Min	Max	
MOEX Min pulse width	$t_{OE\bar{W}}$	MOEX	$V_{cc} \geq 4.5V$	MCLK $\times$ n-3	-	ns
			$V_{cc} < 4.5V$			
MCSX $\downarrow \rightarrow$ Address output delay time	$t_{CSL-AV}$	MCSX[7:0] MAD[24:0]	$V_{cc} \geq 4.5V$	-9	9	ns
			$V_{cc} < 4.5V$	-12	12	
MOEX $\uparrow \rightarrow$ Address hold time	$t_{OE\bar{H}-AX}$	MOEX MAD[24:0]	$V_{cc} \geq 4.5V$	0	MCLK $\times$ m+9	ns
			$V_{cc} < 4.5V$		MCLK $\times$ m+12	
MCSX $\downarrow \rightarrow$ MOEX $\downarrow$ delay time	$t_{CSL-OEL}$	MOEX MCSX[7:0]	$V_{cc} \geq 4.5V$	MCLK $\times$ m-9	MCLK $\times$ m+9	ns
			$V_{cc} < 4.5V$	MCLK $\times$ m-12	MCLK $\times$ m+12	
MOEX $\uparrow \rightarrow$ MCSX $\uparrow$ time	$t_{OE\bar{H}-OSH}$	MCSX[7:0]	$V_{cc} \geq 4.5V$	0	MCLK $\times$ m+9	ns
			$V_{cc} < 4.5V$		MCLK $\times$ m+12	
MCSX $\downarrow \rightarrow$ MDQM $\downarrow$ delay time	$t_{CSL-RDQML}$	MOEX MDQM[1:0]	$V_{cc} \geq 4.5V$	MCLK $\times$ m-9	MCLK $\times$ m+9	ns
			$V_{cc} < 4.5V$	MCLK $\times$ m-12	MCLK $\times$ m+12	
Data set up $\rightarrow$ MOEX $\uparrow$ time	$t_{DS-OE}$	MOEX MADATA[15:0]	$V_{cc} \geq 4.5V$	20	-	ns
			$V_{cc} < 4.5V$	38	-	
MOEX $\uparrow \rightarrow$ Data hold time	$t_{DH-OE}$	MOEX MADATA[15:0]	$V_{cc} \geq 4.5V$	0	-	ns
			$V_{cc} < 4.5V$			
MWEX Min pulse width	$t_{WE\bar{W}}$	MWEX	$V_{cc} \geq 4.5V$	MCLK $\times$ n-3	-	ns
			$V_{cc} < 4.5V$			
MWEX $\uparrow \rightarrow$ Address output delay time	$t_{WE\bar{H}-AX}$	MWEX MAD[24:0]	$V_{cc} \geq 4.5V$	0	MCLK $\times$ m+9	ns
			$V_{cc} < 4.5V$		MCLK $\times$ m+12	
MCSX $\downarrow \rightarrow$ MWEX $\downarrow$ delay time	$t_{CSL-WEL}$	MWEX MCSX[7:0]	$V_{cc} \geq 4.5V$	MCLK $\times$ n-9	MCLK $\times$ n+9	ns
			$V_{cc} < 4.5V$	MCLK $\times$ n-12	MCLK $\times$ n+12	
MWEX $\uparrow \rightarrow$ MCSX $\uparrow$ delay time	$t_{WE\bar{H}-CSH}$	MCSX[7:0]	$V_{cc} \geq 4.5V$	0	MCLK $\times$ m+9	ns
			$V_{cc} < 4.5V$		MCLK $\times$ m+12	
MCSX $\downarrow \rightarrow$ MDQM $\downarrow$ delay time	$t_{CSL-WDQML}$	MCSX MDQM[1:0]	$V_{cc} \geq 4.5V$	MCLK $\times$ n-9	MCLK $\times$ n+9	ns
			$V_{cc} < 4.5V$	MCLK $\times$ n-12	MCLK $\times$ n+12	
MWEX $\downarrow \rightarrow$ Data output time	$t_{WEL-DV}$	MWEX MADATA[15:0]	$V_{cc} \geq 4.5V$	-9	9	ns
			$V_{cc} < 4.5V$	-12	12	
MWEX $\uparrow \rightarrow$ Data hold time	$t_{WE\bar{H}-DX}$	MADATA[15:0]	$V_{cc} \geq 4.5V$	0	MCLK $\times$ m+9	ns
			$V_{cc} < 4.5V$		MCLK $\times$ m+12	

Note: When the external load capacitance = 30pF (m = 0 to 15, n = 1 to 16).



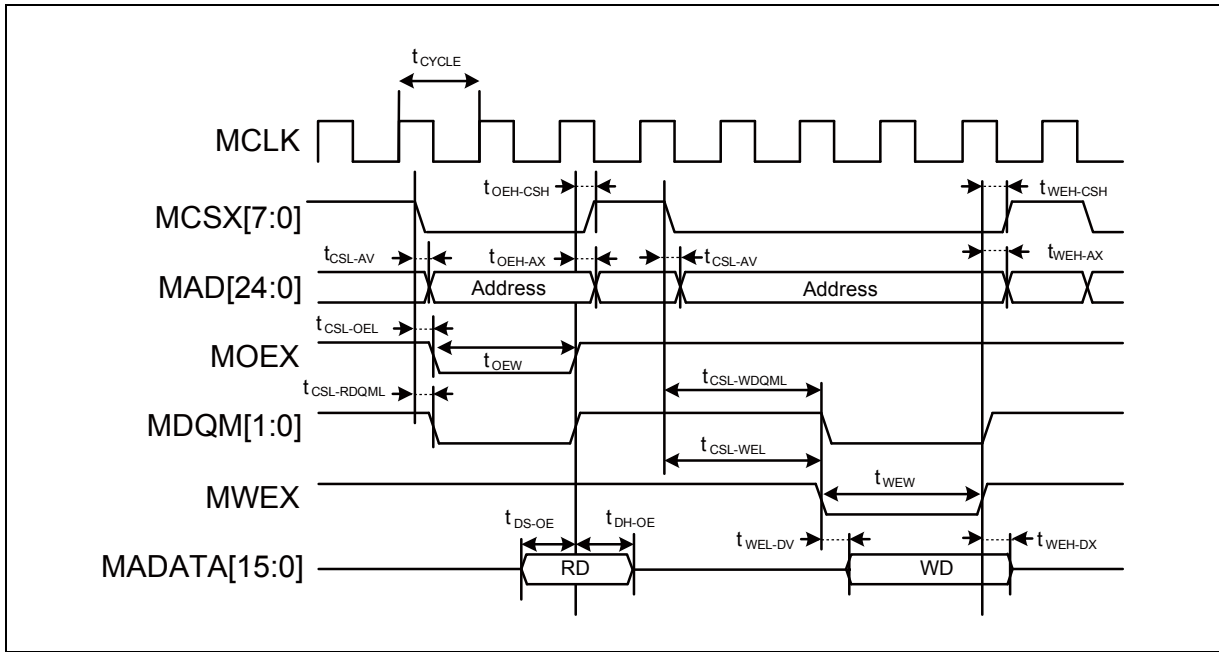

# MB9A110 Series

• Separate Bus Access Synchronous SRAM Mode

( $V_{CC} = 2.7V$  to  $5.5V$ ,  $V_{SS} = 0V$ ,  $T_a = -40^{\circ}C$  to  $+105^{\circ}C$ )

Parameter	Symbol	Pin name	Conditions	Value		Unit
				Min	Max	
Address delay time	$t_{AV}$	MCLK MAD[24:0]	$V_{CC} \geq 4.5V$	1	9	ns
			$V_{CC} < 4.5V$		12	
MCSX delay time	$t_{CSL}$	MCLK MCSX[7:0]	$V_{CC} \geq 4.5V$	1	9	ns
			$V_{CC} < 4.5V$		12	
	$t_{CSH}$		$V_{CC} \geq 4.5V$	1	9	ns
			$V_{CC} < 4.5V$		12	
MOEX delay time	$t_{REL}$	MCLK MOEX	$V_{CC} \geq 4.5V$	1	9	ns
			$V_{CC} < 4.5V$		12	
	$t_{REH}$		$V_{CC} \geq 4.5V$	1	9	ns
			$V_{CC} < 4.5V$		12	
Data set up → MCLK ↑ time	$t_{DS}$	MCLK MADATA[15:0]	$V_{CC} \geq 4.5V$	19	-	ns
			$V_{CC} < 4.5V$			
MCLK ↑ → Data hold time	$t_{DH}$	MCLK MADATA[15:0]	$V_{CC} \geq 4.5V$	0	-	ns
			$V_{CC} < 4.5V$			
MWEX delay time	$t_{WEL}$	MCLK MWEX	$V_{CC} \geq 4.5V$	1	9	ns
			$V_{CC} < 4.5V$		12	
	$t_{WEH}$		$V_{CC} \geq 4.5V$	1	9	ns
			$V_{CC} < 4.5V$		12	
MDQM[1:0] delay time	$t_{DQML}$	MCLK MDQM[1:0]	$V_{CC} \geq 4.5V$	1	9	ns
			$V_{CC} < 4.5V$		12	
	$t_{DQMH}$		$V_{CC} \geq 4.5V$	1	9	ns
			$V_{CC} < 4.5V$		12	
MCLK ↑ → Data output time	$t_{OD}$	MCLK MADATA[15:0]	$V_{CC} \geq 4.5V$	2	18	ns
			$V_{CC} < 4.5V$		24	

Note: When the external load capacitance = 30pF.

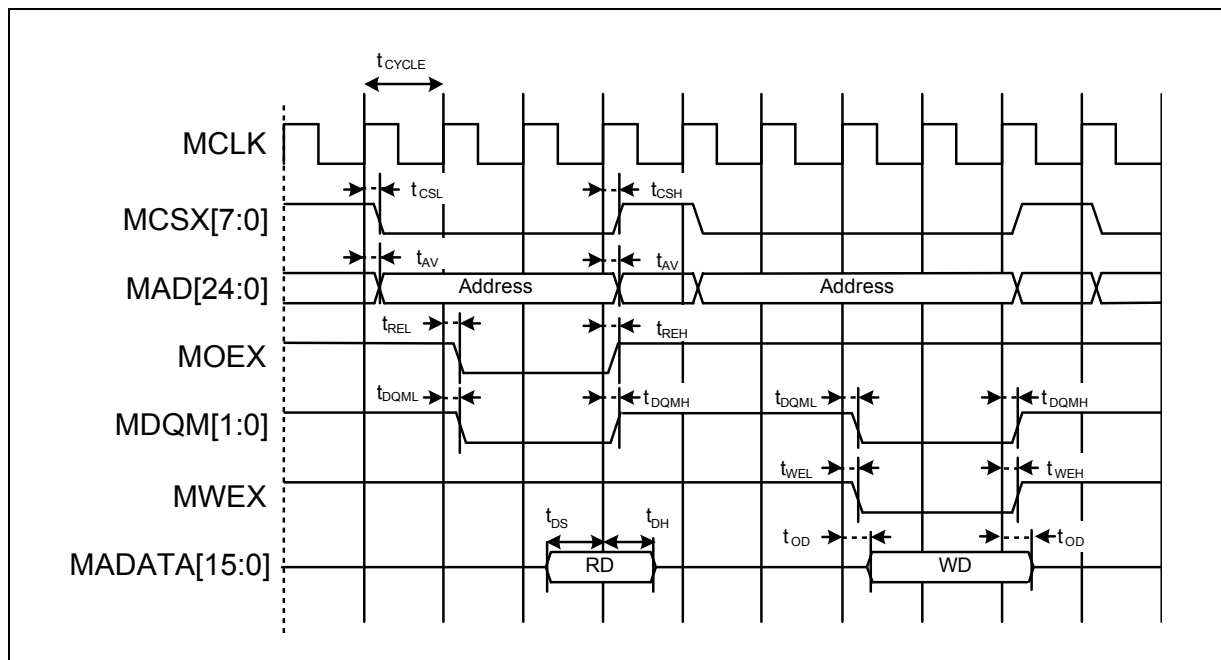

# MB9A110 Series

• Multiplexed Bus Access Asynchronous SRAM Mode

( $V_{CC} = 2.7V$  to  $5.5V$ ,  $V_{SS} = 0V$ ,  $T_a = -40^{\circ}C$  to  $+105^{\circ}C$ )

Parameter	Symbol	Pin name	Conditions	Value		Unit
				Min	Max	
Multiplexed Address delay time	$t_{ALE-CHMADV}$	MALE MADATA[15:0]	$V_{CC} \geq 4.5V$	0	10	ns
			$V_{CC} < 4.5V$		20	
Multiplexed Address hold time	$t_{CHMADH}$	MALE MADATA[15:0]	$V_{CC} \geq 4.5V$	$MCLK \times n + 0$	$MCLK \times n + 10$	ns
			$V_{CC} < 4.5V$	$MCLK \times n + 0$	$MCLK \times n + 20$	

Note: When the external load capacitance = 30pF (m = 0 to 15, n = 1 to 16).

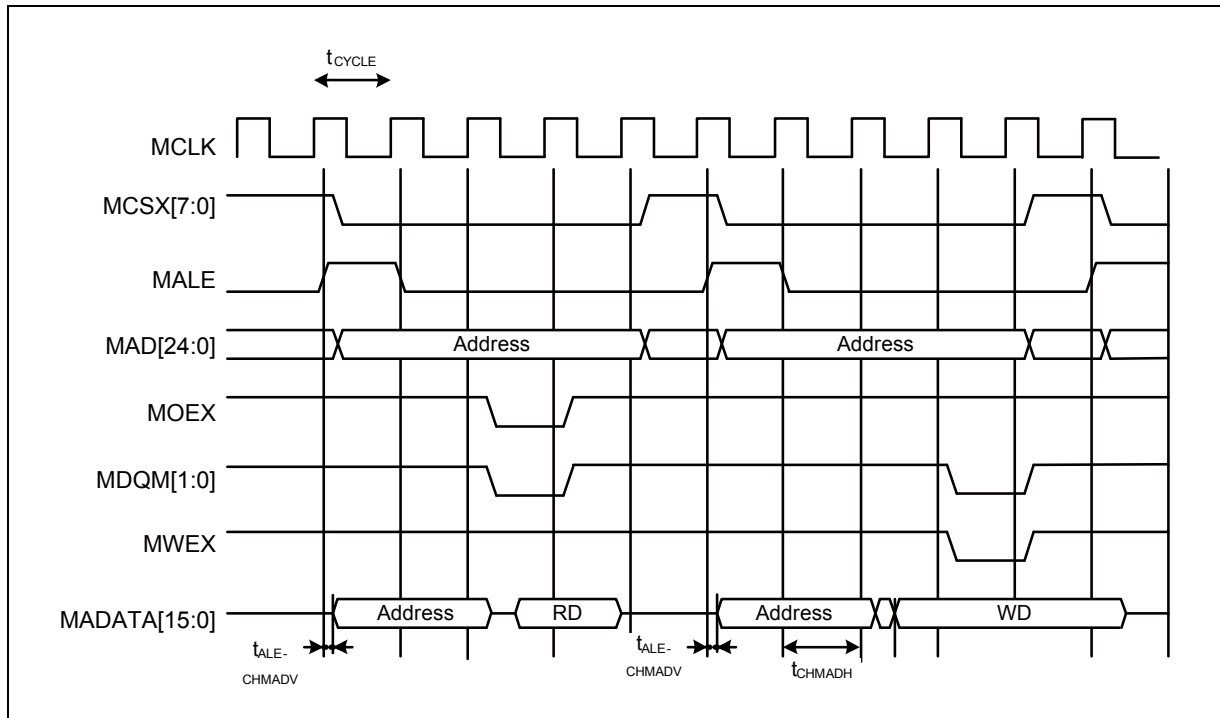

# MB9A110 Series

• Multiplexed Bus Access Synchronous SRAM Mode

(Vcc = 2.7V to 5.5V, Vss = 0V, Ta = - 40°C to + 105°C)

Parameter	Symbol	Pin name	Conditions	Value		Unit	Remarks
				Min	Max		
MALE delay time	t <sub>CHAL</sub>	MCLK ALE	Vcc ≥ 4.5V	1	9	ns	
			Vcc < 4.5V		12		
	t <sub>CHAH</sub>		Vcc ≥ 4.5V	1	9	ns	
			Vcc < 4.5V		12		
MCLK ↑ → Multiplexed Address delay time	t <sub>CHMADV</sub>	MCLK MADATA[15:0]	Vcc ≥ 4.5V	1	t <sub>OD</sub>	ns	
Vcc < 4.5V							
MCLK ↑ → Multiplexed Data output time	t <sub>CHMADX</sub>	MCLK MADATA[15:0]	Vcc ≥ 4.5V	1	t <sub>OD</sub>	ns	
Vcc < 4.5V							

Note: When the external load capacitance = 30pF.

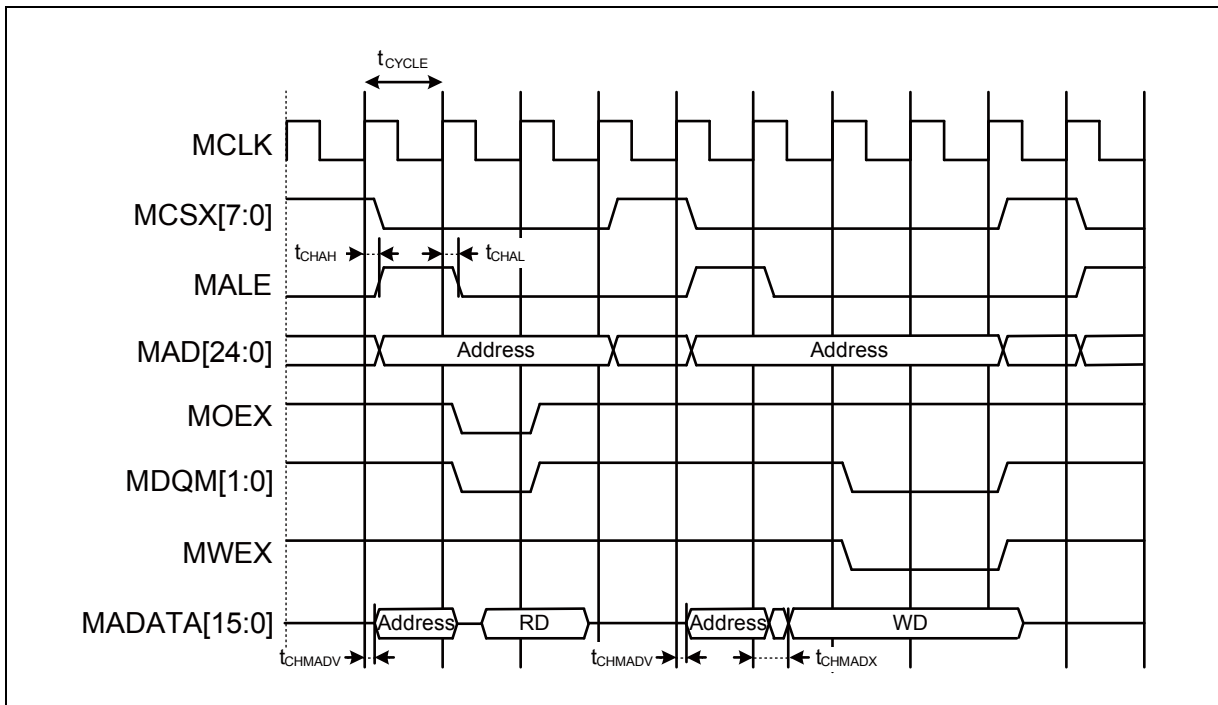

• External Ready Input Timing

( $V_{CC} = 2.7V$  to  $5.5V$ ,  $V_{SS} = 0V$ ,  $T_a = -40^{\circ}C$  to  $+105^{\circ}C$ )

Parameter	Symbol	Pin name	Conditions	Value		Unit	Remarks
				Min	Max		
MCLK $\uparrow$ MRDY input setup time	$t_{RDYI}$	MCLK MRDY	$V_{CC} \geq 4.5V$	19	-	ns	
			$V_{CC} < 4.5V$	37			

When RDY input

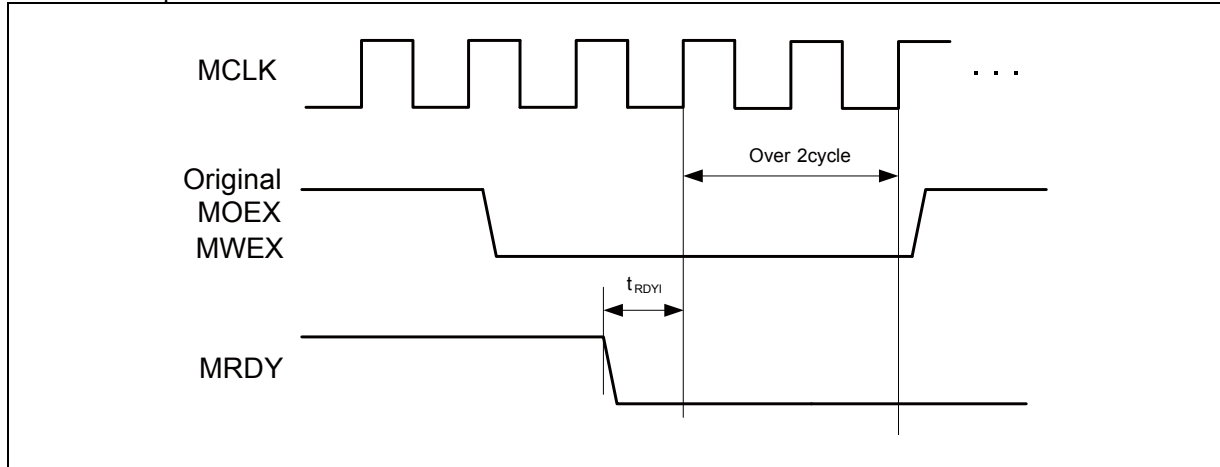

When RDY release

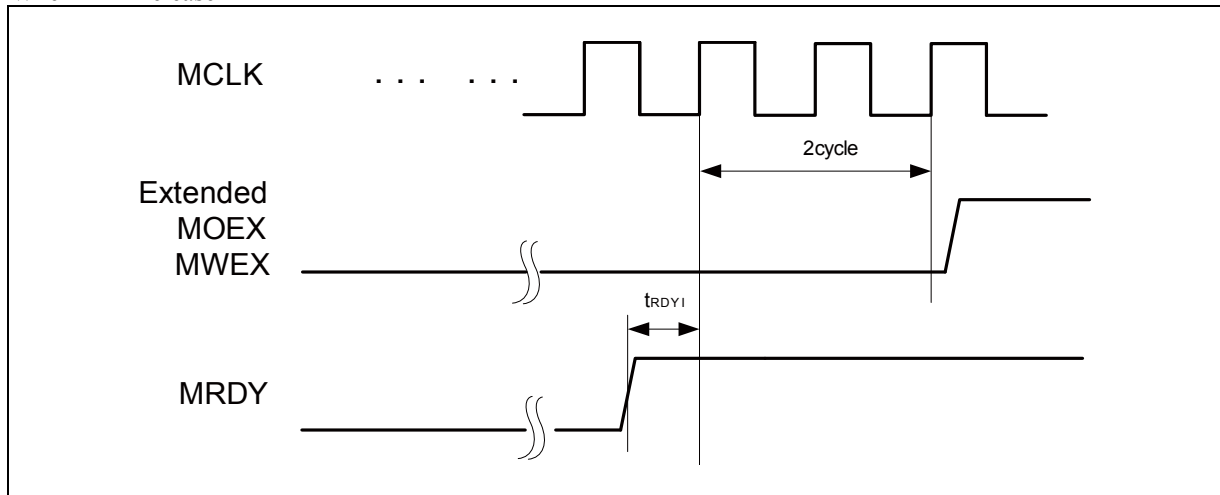

# MB9A110 Series

## (8) Base Timer Input Timing

- Timer input timing

(V<sub>CC</sub> = 2.7V to 5.5V, V<sub>SS</sub> = 0V, T<sub>a</sub> = - 40°C to + 105°C)

Parameter	Symbol	Pin name	Conditions	Value		Unit	Remarks
				Min	Max		
Input pulse width	$t_{TIWH}$ $t_{TIWL}$	TIOAn/TIOBn (when using as ECK, TIN)	-	$2t_{CYCP}$	-	ns	

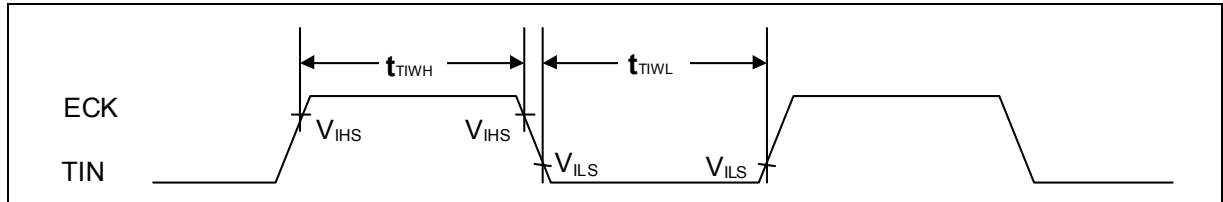

- Trigger input timing

(V<sub>CC</sub> = 2.7V to 5.5V, V<sub>SS</sub> = 0V, T<sub>a</sub> = - 40°C to + 105°C)

Parameter	Symbol	Pin name	Conditions	Value		Unit	Remarks
				Min	Max		
Input pulse width	$t_{TRGH}$ $t_{TRGL}$	TIOAn/TIOBn (when using as TGIN)	-	$2t_{CYCP}$	-	ns	

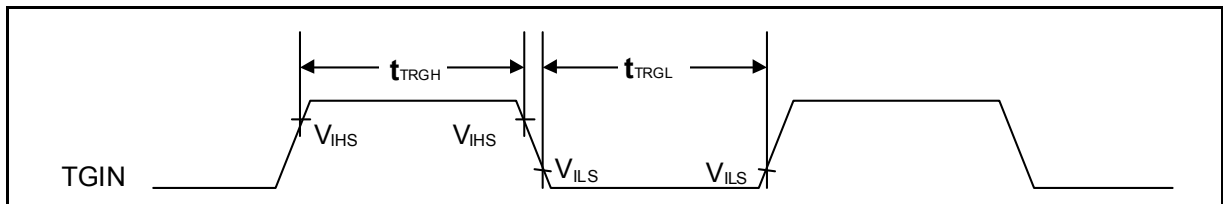

## (9) UART Timing

- Synchronous serial (SPI = 0, SCINV = 0)

(Vcc = 2.7V to 5.5V, Vss = 0V, Ta = - 40°C to + 105°C)

Parameter	Symbol	Pin name	Conditions	Vcc < 4.5V		Vcc ≥ 4.5V		Unit
				Min	Max	Min	Max	
Serial clock cycle time	tSCYC	SCKx	Internal shift clock operation	4tcycp	-	4tcycp	-	ns
SCK ↓ → SOT delay time	tSLOVI	SCKx SOTx		-30	+30	- 20	+ 20	ns
SIN → SCK ↑ setup time	tIVSHI	SCKx SINx		50	-	30	-	ns
SCK ↑ → SIN hold time	tSHIXI	SCKx SINx		0	-	0	-	ns
Serial clock "L" pulse width	tSLSH	SCKx	External shift clock operation	2tcycp - 10	-	2tcycp - 10	-	ns
Serial clock "H" pulse width	tSHSL	SCKx		tcycp + 10	-	tcycp + 10	-	ns
SCK ↓ → SOT delay time	tSLOVE	SCKx SOTx		-	50	-	30	ns
SIN → SCK ↑ setup time	tIVSHE	SCKx SINx		10	-	10	-	ns
SCK ↑ → SIN hold time	tSHIXE	SCKx SINx		20	-	20	-	ns
SCK fall time	tF	SCKx		-	5	-	5	ns
SCK rise time	tR	SCKx		-	5	-	5	ns

- Notes:
- The above characteristics apply to CLK synchronous mode.
  - t<sub>CYCP</sub> indicates the APB bus clock cycle time. Please see the block diagram to refer the APB bus number which UART is connected.
  - These characteristics only guarantee the same relocate port number.  
For example, the combination of SCLKx\_0 and SOTx\_1 is not guaranteed.
  - When the external load capacitance = 30pF.

# MB9A110 Series

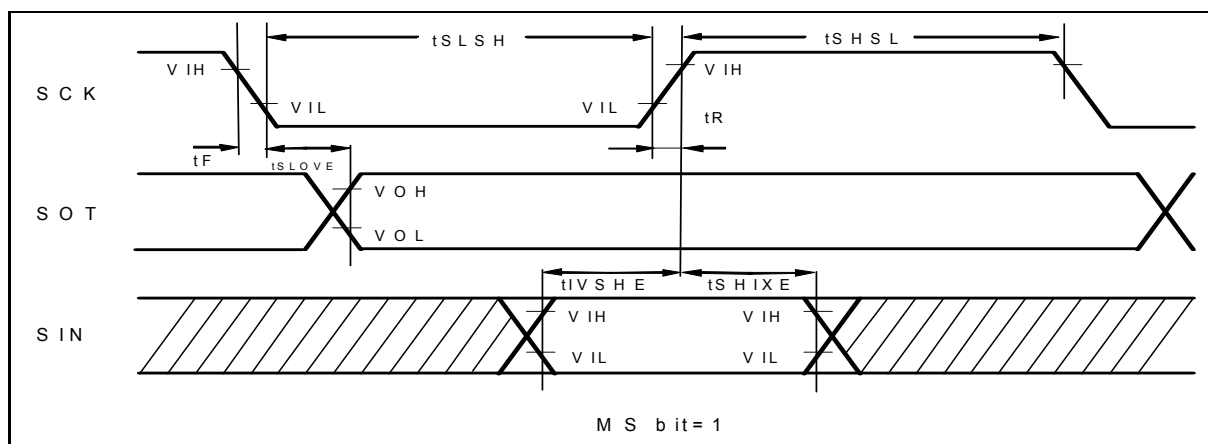
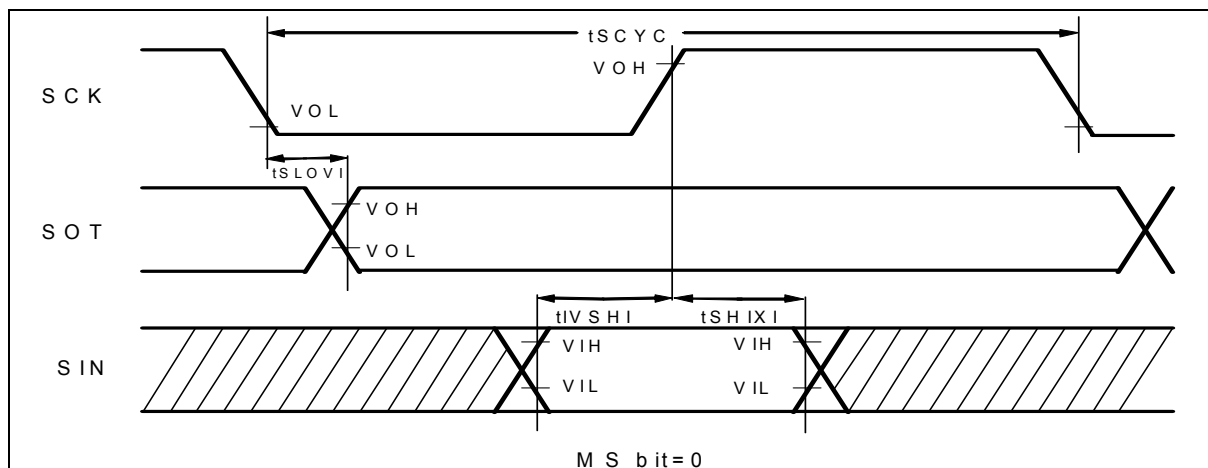



# MB9A110 Series

• Synchronous serial(SPI = 0, SCINV = 1)

(Vcc = 2.7V to 5.5V, Vss = 0V, Ta = - 40°C to + 105°C)

Parameter	Symbol	Pin name	Conditions	Vcc < 4.5V		Vcc ≥ 4.5V		Unit
				Min	Max	Min	Max	
Serial clock cycle time	tSCYC	SCKx	Internal shift clock operation	4tcycp	-	4tcycp	-	ns
SCK ↑ → SOT delay time	tSHOVI	SCKx SOTx		-30	+30	- 20	+ 20	ns
SIN → SCK ↓ setup time	tIVSLI	SCKx SINx		50	-	30	-	ns
SCK ↓ → SIN hold time	tSLIXI	SCKx SINx		0	-	0	-	ns
Serial clock "L" pulse width	tSLSH	SCKx	External shift clock operation	2tcycp - 10	-	2tcycp - 10	-	ns
Serial clock "H" pulse width	tSHSL	SCKx		tcycp + 10	-	tcycp + 10	-	ns
SCK ↑ → SOT delay time	tSHOVE	SCKx SOTx		-	50	-	30	ns
SIN → SCK ↓ setup time	tIVSLE	SCKx SINx		10	-	10	-	ns
SCK ↓ → SIN hold time	tSLIXE	SCKx SINx		20	-	20	-	ns
SCK fall time	tF	SCKx		-	5	-	5	ns
SCK rise time	tR	SCKx		-	5	-	5	ns

- Notes:
- The above characteristics apply to CLK synchronous mode.
  - t<sub>CYCP</sub> indicates the APB bus clock cycle time. Please see the block diagram to refer the APB bus number which UART is connected.
  - These characteristics only guarantee the same relocate port number.  
For example, the combination of SCLKx\_0 and SOTx\_1 is not guaranteed.
  - When the external load capacitance = 30pF.

# MB9A110 Series

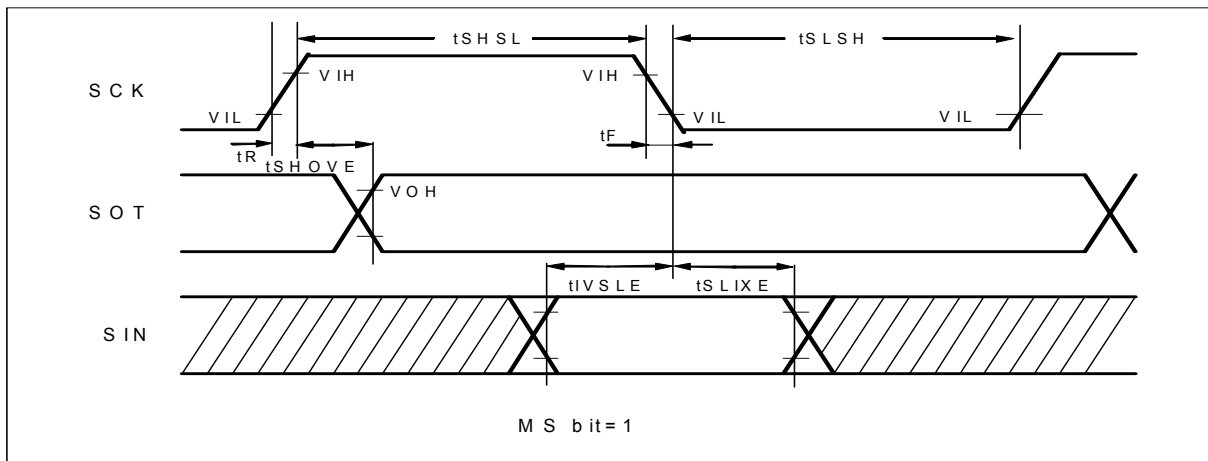
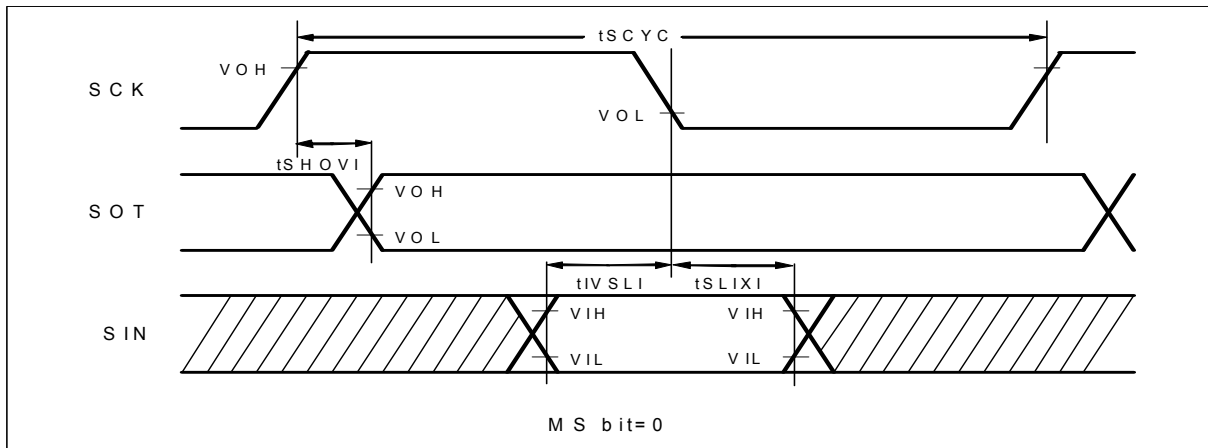

# MB9A110 Series

- Synchronous serial(SPI = 1, SCINV = 0)

(Vcc = 2.7V to 5.5V, Vss = 0V, Ta = - 40°C to + 105°C)

Parameter	Symbol	Pin name	Conditions	Vcc < 4.5V		Vcc ≥ 4.5V		Unit
				Min	Max	Min	Max	
Serial clock cycle time	tSCYC	SCKx	Internal shift clock operation	4tcycp	-	4tcycp	-	ns
SCK ↑ → SOT delay time	tSHOVI	SCKx SOTx		-30	+30	- 20	+ 20	ns
SIN → SCK ↓ setup time	tIVSLI	SCKx SINx		50	-	30	-	ns
SCK ↓ → SIN hold time	tSLIXI	SCKx SINx		0	-	0	-	ns
SOT → SCK ↓ delay time	tSOVLI	SCKx SOTx		2tcycp - 30	-	2tcycp - 30	-	ns
Serial clock "L" pulse width	tSLSH	SCKx		2tcycp - 10	-	2tcycp - 10	-	ns
Serial clock "H" pulse width	tSHSL	SCKx	tcycp + 10	-	tcycp + 10	-	ns	
SCK ↑ → SOT delay time	tSHOVE	SCKx SOTx	External shift clock operation	-	50	-	30	ns
SIN → SCK ↓ setup time	tIVSLE	SCKx SINx		10	-	10	-	ns
SCK ↓ → SIN hold time	tSLIXE	SCKx SINx		20	-	20	-	ns
SCK fall time	tF	SCKx		-	5	-	5	ns
SCK rise time	tR	SCKx		-	5	-	5	ns

- Notes:
- The above characteristics apply to CLK synchronous mode.
  - t<sub>CYCP</sub> indicates the APB bus clock cycle time. Please see the block diagram to refer the APB bus number which UART is connected.
  - These characteristics only guarantees the same relocate port number.  
For example, the combination of SCLKx\_0 and SOTx\_1 is not guaranteed.
  - When the external load capacitance = 30pF.

# MB9A110 Series

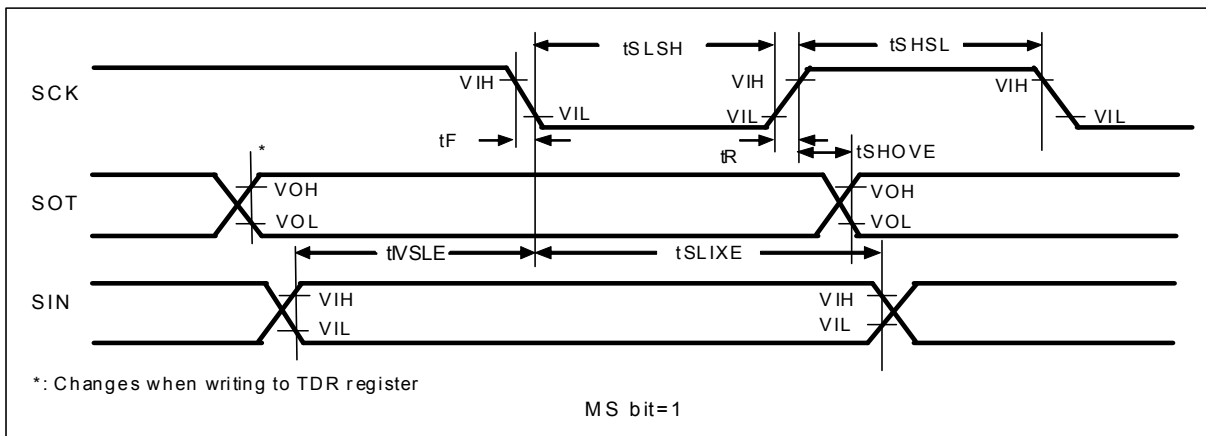
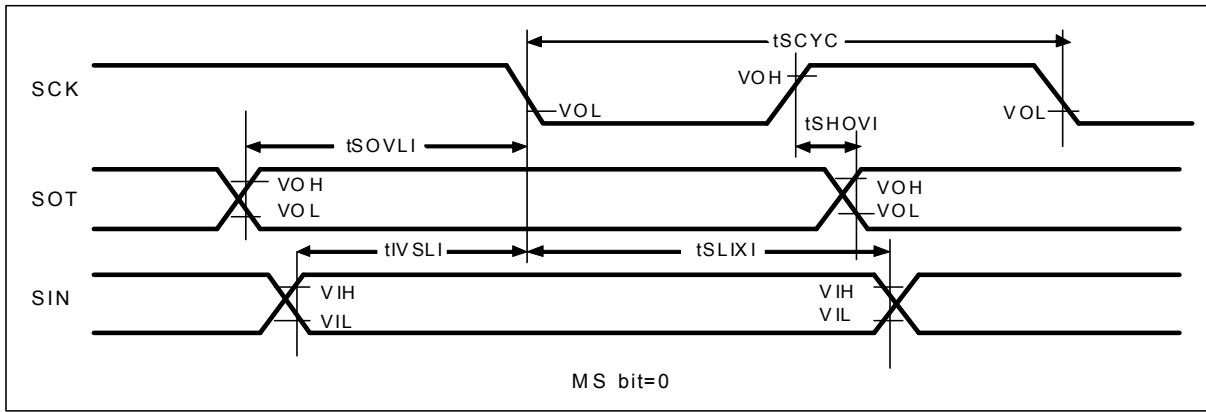

# MB9A110 Series

• Synchronous serial(SPI = 1, SCINV = 1)

(V<sub>CC</sub> = 2.7V to 5.5V, V<sub>SS</sub> = 0V, Ta = - 40°C to + 105°C)

Parameter	Symbol	Pin name	Conditions	V <sub>CC</sub> < 4.5V		V <sub>CC</sub> ≥ 4.5V		Unit
				Min	Max	Min	Max	
Serial clock cycle time	tSCYC	SCK <sub>x</sub>	Internal shift clock operation	4tcycp	-	4tcycp	-	ns
SCK ↓ → SOT delay time	tSLOVI	SCK <sub>x</sub> SOT <sub>x</sub>		-30	+30	- 20	+ 20	ns
SIN → SCK ↑ setup time	tIVSHI	SCK <sub>x</sub> SIN <sub>x</sub>		50	-	30	-	ns
SCK ↑ → SIN hold time	tSHIXI	SCK <sub>x</sub> SIN <sub>x</sub>		0	-	0	-	ns
SOT → SCK ↑ delay time	tSOVHI	SCK <sub>x</sub> SOT <sub>x</sub>		2tcycp - 30	-	2tcycp - 30	-	ns
Serial clock "L" pulse width	tSLSH	SCK <sub>x</sub>	External shift clock operation	2tcycp - 10	-	2tcycp - 10	-	ns
Serial clock "H" pulse width	tSHSL	SCK <sub>x</sub>		tcycp + 10	-	tcycp + 10	-	ns
SCK ↓ → SOT delay time	tSLOVE	SCK <sub>x</sub> SOT <sub>x</sub>		-	50	-	30	ns
SIN → SCK ↑ setup time	tIVSHE	SCK <sub>x</sub> SIN <sub>x</sub>		10	-	10	-	ns
SCK ↑ → SIN hold time	tSHIXE	SCK <sub>x</sub> SIN <sub>x</sub>		20	-	20	-	ns
SCK fall time	tF	SCK <sub>x</sub>		-	5	-	5	ns
SCK rise time	tR	SCK <sub>x</sub>		-	5	-	5	ns

- Notes:
- The above characteristics apply to CLK synchronous mode.
  - t<sub>CYCP</sub> indicates the APB bus clock cycle time. Please see the block diagram to refer the APB bus number which UART is connected.
  - These characteristics only guarantee the same relocate port number.  
For example, the combination of SCLK<sub>x\_0</sub> and SOT<sub>x\_1</sub> is not guaranteed.
  - When the external load capacitance = 30pF.

# MB9A110 Series

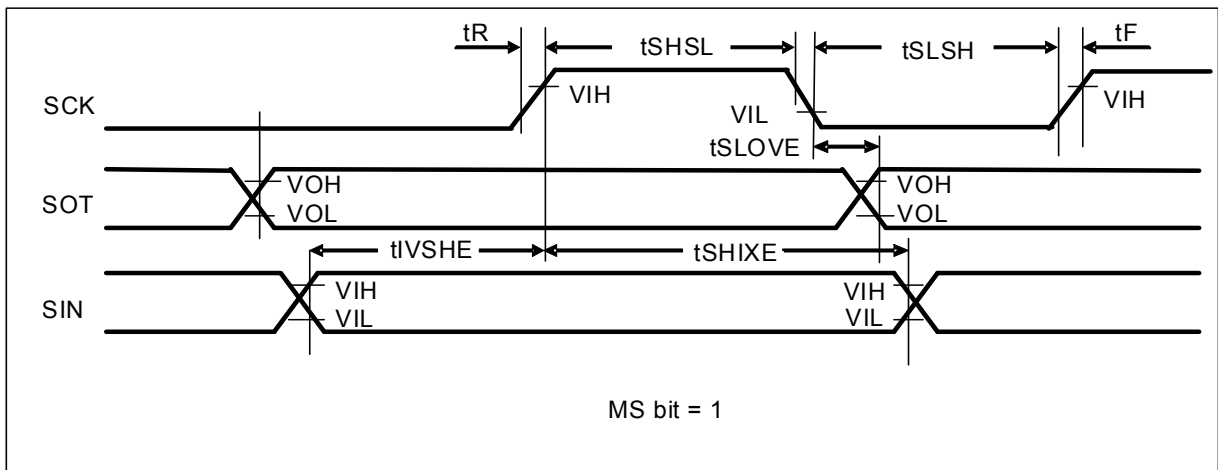
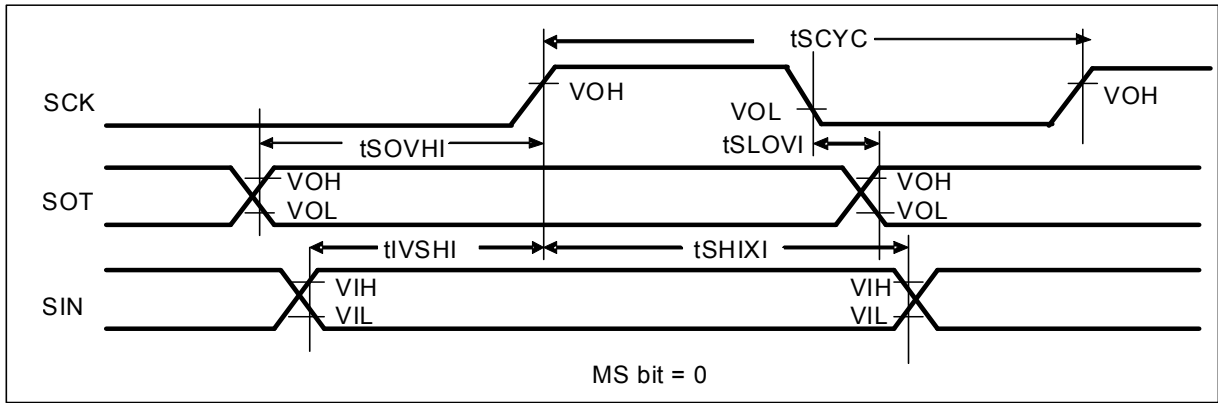

• External clock (EXT = 1) : asynchronous only

( $V_{CC} = 2.7V$  to  $5.5V$ ,  $V_{SS} = 0V$ ,  $T_a = -40^{\circ}C$  to  $+105^{\circ}C$ )

Parameter	Symbol	Conditions	Min	Max	Unit	Remarks
Serial clock "L" pulse width	tSLSH	$C_L = 30pF$	$t_{cycp} + 10$	-	ns	
Serial clock "H" pulse width	tSHSL		$t_{cycp} + 10$	-	ns	
SCK fall time	tF		-	5	ns	
SCK rise time	tR		-	5	ns	

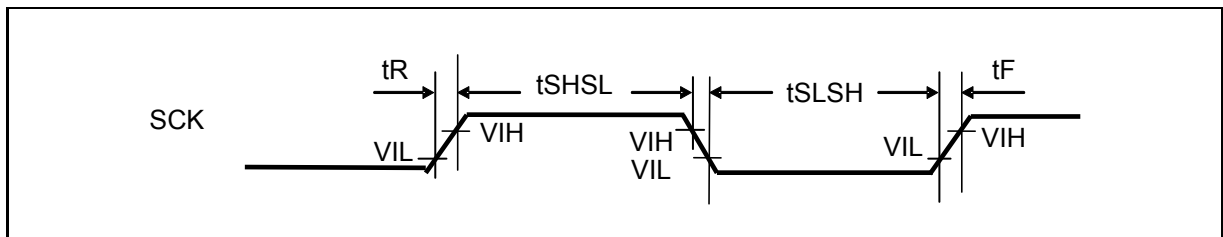

## (10) External input timing

(V<sub>CC</sub> = 2.7V to 5.5V, V<sub>SS</sub> = 0V, T<sub>a</sub> = - 40°C to + 105°C)

Parameter	Symbol	Pin name	Conditions	Value		Unit	Remarks
				Min	Max		
Input pulse width	t <sub>INH</sub> t <sub>INL</sub>	ADTG	-	2t <sub>CYCP</sub> * <sup>1</sup>	-	ns	A/D converter trigger input
		FRCK <sub>x</sub>					Free-run timer input clock
		IC <sub>XX</sub>					Input capture
		DTTIX <sub>X</sub>	-	2t <sub>CYCP</sub> * <sup>1</sup>	-	ns	Wave form generator
		INT00 to INT15, NMIX	-	2t <sub>CYCP</sub> + 100* <sup>1</sup>	-	ns	External interrupt
				500* <sup>2</sup>	-	ns	NMI

\*1: t<sub>CYCP</sub> indicates the APB bus clock cycle time except stop when in stop mode. Please see the block diagram to refer the APB bus number which Multi function timer is connected.

\*2: When in stop mode, in timer mode.

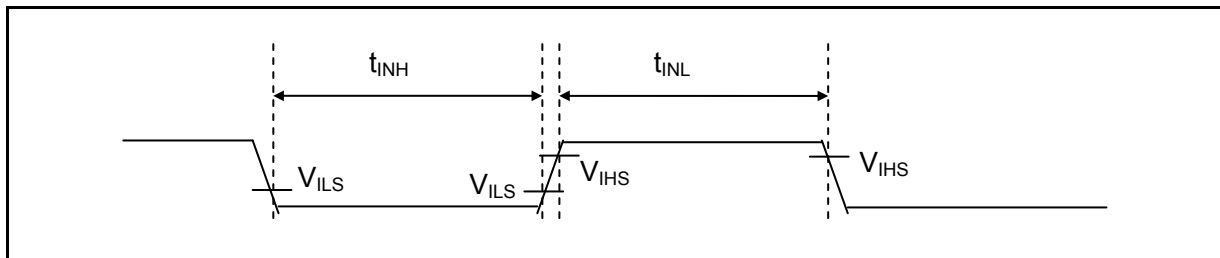

# MB9A110 Series

## (11) Quadrature Position/Revolution Counter timing

(V<sub>CC</sub> = 2.7V to 5.5V, V<sub>SS</sub> = 0V, T<sub>a</sub> = - 40°C to + 105°C)

Parameter	Symbol	Conditions	Value		Unit
			Min	Max	
AIN pin "H" width	tAHL	-	2t <sub>CYCP</sub> *	-	ns
AIN pin "L" width	tALL	-			
BIN pin "H" width	tBHL	-			
BIN pin "L" width	tBLL	-			
BIN rise time from AIN pin "H" level	tAUBU	PC_Mode2 or PC_Mode3			
AIN fall time from BIN pin "H" level	tBUAD	PC_Mode2 or PC_Mode3			
BIN fall time from AIN pin "L" level	tADBD	PC_Mode2 or PC_Mode3			
AIN rise time from BIN pin "L" level	tBDAU	PC_Mode2 or PC_Mode3			
AIN rise time from BIN pin "H" level	tBUAU	PC_Mode2 or PC_Mode3			
BIN fall time from AIN pin "H" level	tAUBD	PC_Mode2 or PC_Mode3			
AIN fall time from BIN pin "L" level	tBDAD	PC_Mode2 or PC_Mode3			
BIN rise time from AIN pin "L" level	tADBU	PC_Mode2 or PC_Mode3			
ZIN pin "H" width	tZHL	QCR:CGSC="0"			
ZIN pin "L" width	tZLL	QCR:CGSC="0"			
AIN/BIN rise and fall time from determined ZIN level	tZABE	QCR:CGSC="1"			
Determined ZIN level from AIN/BIN rise and fall time	tABEZ	QCR:CGSC="1"			

\* : t<sub>CYCP</sub> indicates the APB bus clock cycle time except stop when in stop mode. Please see the block diagram to refer the APB bus number which QPRC is connected.

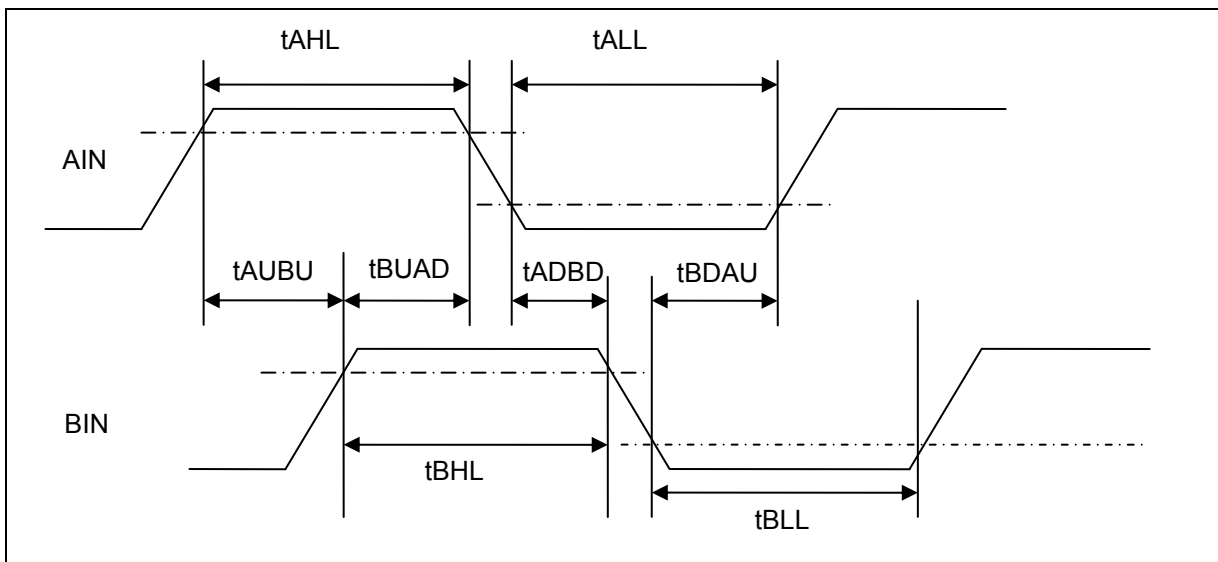



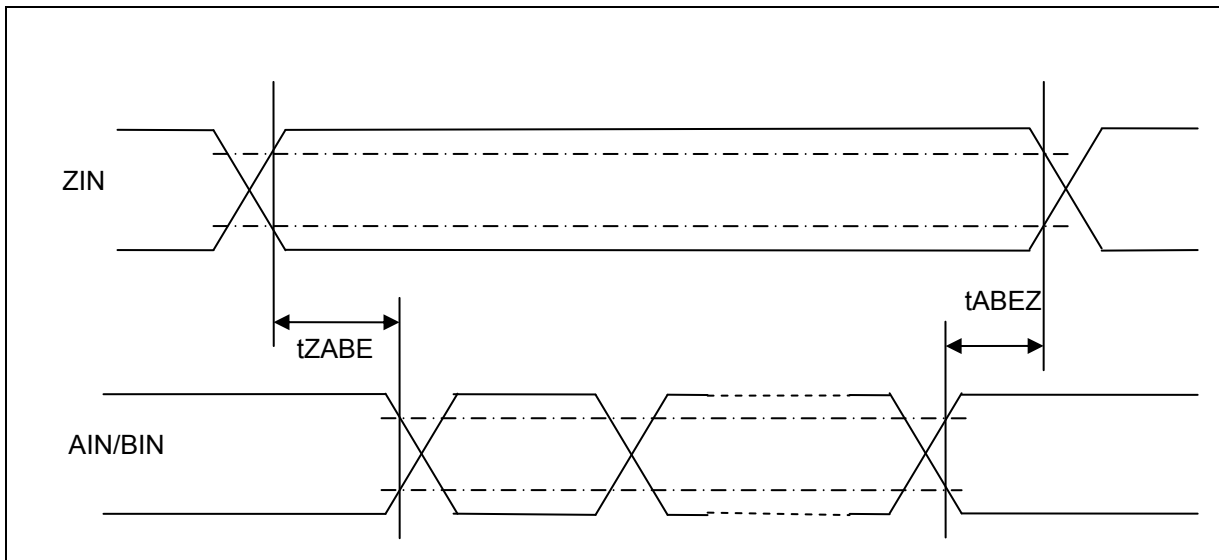
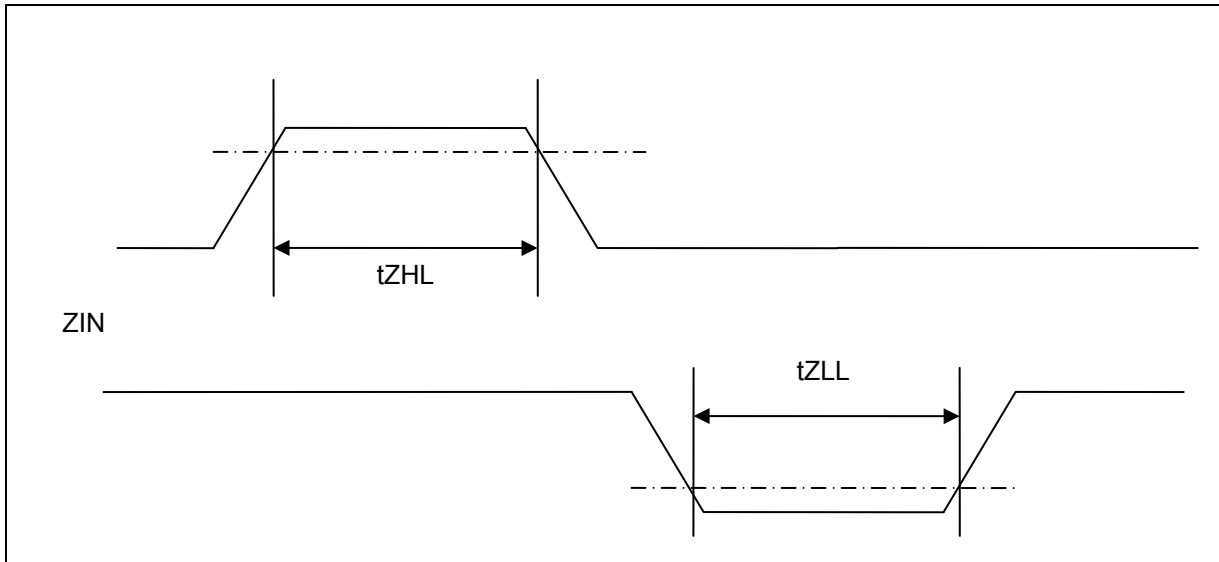
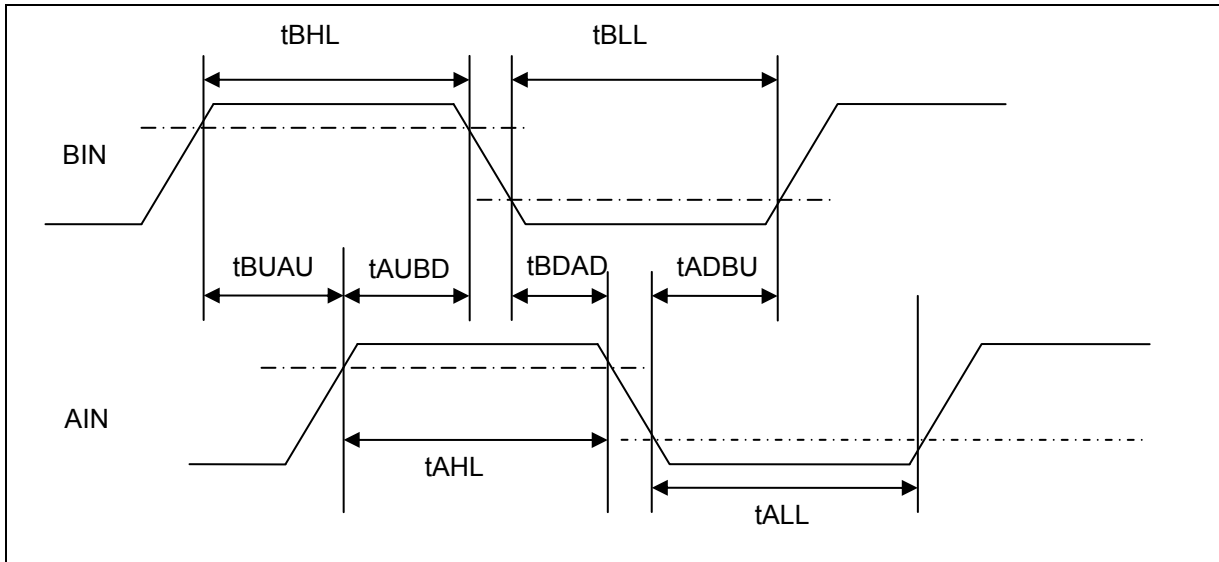

# MB9A110 Series

## (12) I<sup>2</sup>C timing

(V<sub>CC</sub> = 2.7V to 5.5V, V<sub>SS</sub> = 0V, T<sub>a</sub> = - 40°C to + 105°C)

Parameter	Symbol	Conditions	Typical mode		High-speed mode		Unit
			Min	Max	Min	Max	
SCL clock frequency	fSCL	C <sub>L</sub> = 30pF, R = (V <sub>p</sub> /I <sub>OL</sub> ) * <sup>1</sup>	0	100	0	400	kHz
(Repeated) START condition hold time SDA ↓ → SCL ↓	tHDSTA		4.0	-	0.6	-	μs
SCL clock "L" width	tLOW		4.7	-	1.3	-	μs
SCL clock "H" width	tHIGH		4.0	-	0.6	-	μs
(Repeated) START setup time SCL ↑ → SDA ↓	tSUSTA		4.7	-	0.6	-	μs
Data hold time SCL ↓ → SDA ↓ ↑	tHDDAT		0	3.45* <sup>2</sup>	0	0.9* <sup>3</sup>	μs
Data setup time SDA ↓ ↑ → SCL ↑	tSUDAT		250	-	100	-	ns
STOP condition setup time SCL ↑ → SDA ↑	tSUSTO		4.0	-	0.6	-	μs
Bus free time between "STOP condition" and "START condition"	tBUF		4.7	-	1.3	-	μs
Noise filter	tSP		-	2 t <sub>CYCP</sub> * <sup>4</sup>	-	2 t <sub>CYCP</sub> * <sup>4</sup>	ns

\*1 : R and C represent the pull-up resistance and load capacitance of the SCL and SDA lines, respectively. V<sub>p</sub> indicates the power supply voltage of the pull-up resistance and I<sub>OL</sub> indicates V<sub>OL</sub> guaranteed current.

\*2 : The maximum tHDDAT must satisfy that it doesn't extend at least "L" period (tLOW) of device's SCL signal.

\*3 : A high-speed mode I<sup>2</sup>C bus device can be used on a standard mode I<sup>2</sup>C bus system as long as the device satisfies the requirement of "tSUDAT ≥ 250 ns".

\*4 : t<sub>CYCP</sub> is the APB bus clock cycle time. Please see the block diagram to refer the APB bus number which I<sup>2</sup>C is connected. To use I<sup>2</sup>C, set the APB bus clock at 8 MHz or more.

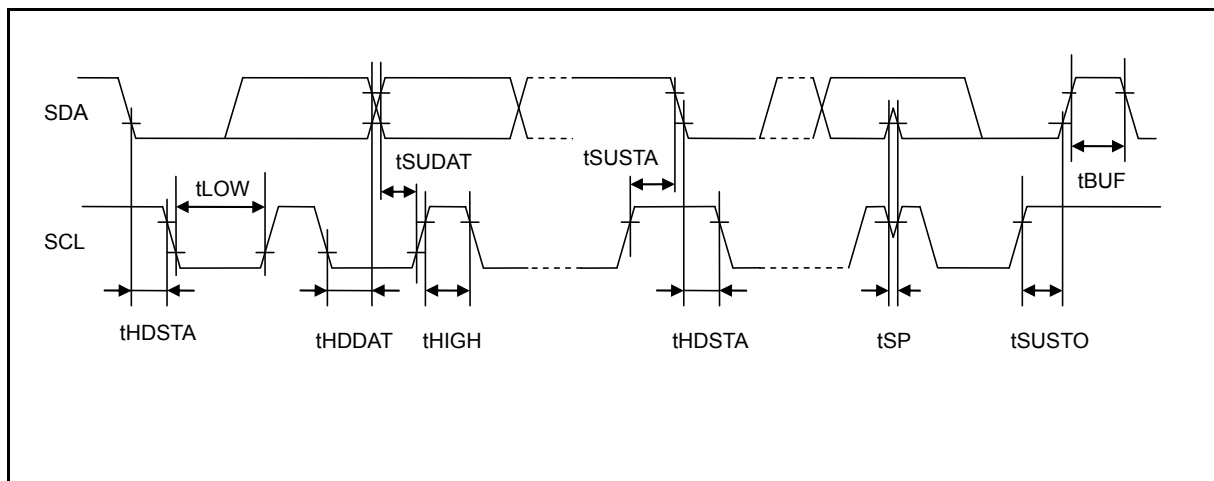

## (13) ETM timing

( $V_{CC} = 2.7V$  to  $5.5V$ ,  $V_{SS} = 0V$ ,  $T_a = -40^{\circ}C$  to  $+105^{\circ}C$ )

Parameter	Symbol	Pin name	Conditions	Value		Unit	Remarks
				Min	Max		
Data hold	$t_{ETMH}$	TRACECLK TRACED3 - 0	$V_{CC} \geq 4.5V$	2	9	ns	
			$V_{CC} < 4.5V$	2	15		
TRACECLK frequency	$1/t_{TRACE}$	TRACECLK	$V_{CC} \geq 4.5V$	-	40	MHz	
			$V_{CC} < 4.5V$	-	32	MHz	
TRACECLK Clock cycle time	$t_{TRACE}$	TRACECLK	$V_{CC} \geq 4.5V$	25	-	ns	
			$V_{CC} < 4.5V$	31.25	-	ns	

Note: When the external load capacitance = 30pF.

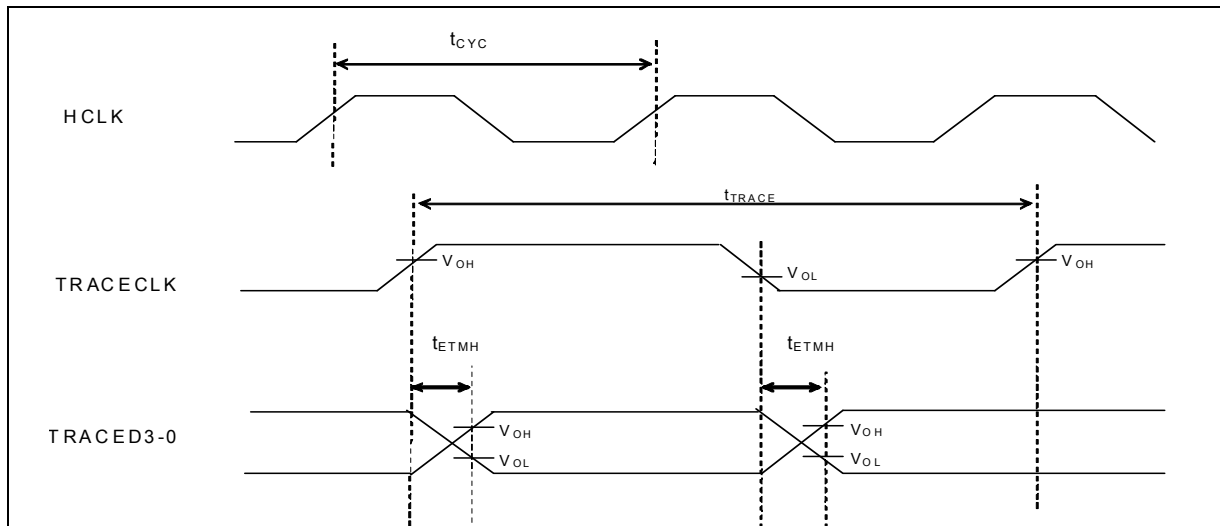

# MB9A110 Series

## (14) JTAG timing

( $V_{CC} = 2.7V$  to  $5.5V$ ,  $V_{SS} = 0V$ ,  $T_a = -40^{\circ}C$  to  $+105^{\circ}C$ )

Parameter	Symbol	Pin name	Conditions	Value		Unit	Remarks
				Min	Max		
TMS, TDI setup time	$t_{JTAGS}$	TCK TMS, TDI	$V_{CC} \geq 4.5V$	15	-	ns	
			$V_{CC} < 4.5V$				
TMS, TDI hold time	$t_{JTAGH}$	TCK TMS, TDI	$V_{CC} \geq 4.5V$	15	-	ns	
			$V_{CC} < 4.5V$				
TDO delay time	$t_{JTAGD}$	TCK TDO	$V_{CC} \geq 4.5V$	-	25	ns	
			$V_{CC} < 4.5V$	-	45		

Note: When the external load capacitance = 30pF.

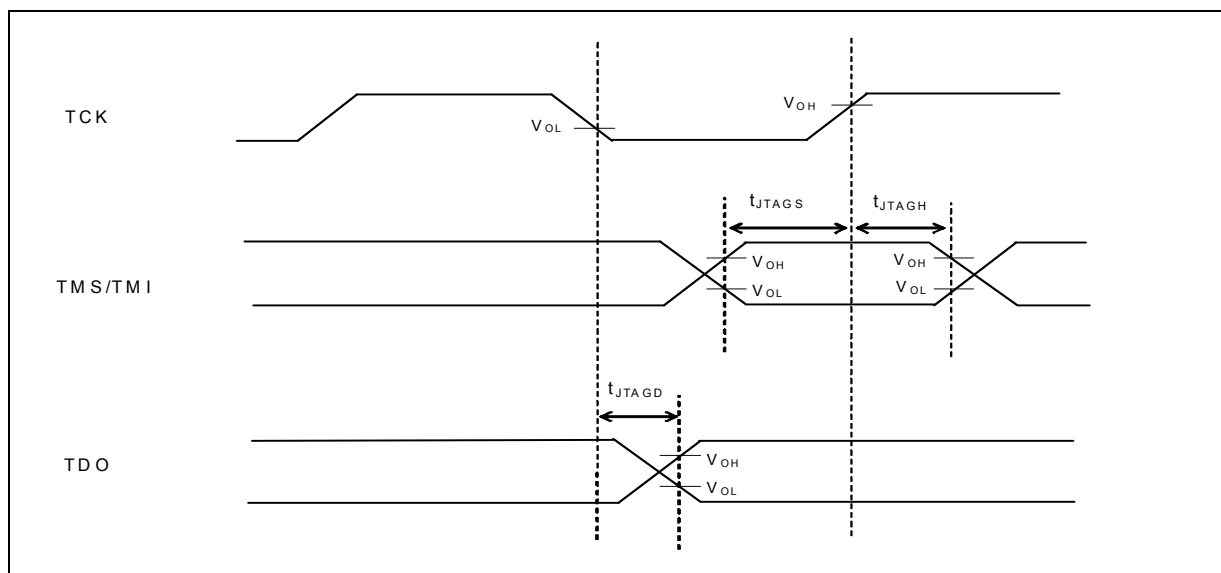

## ● 12bit A/D Converter

### 1. Electrical characteristics for the A/D converter (Provisional value)

(V<sub>cc</sub> = AV<sub>cc</sub> = 2.7V to 5.5V, V<sub>ss</sub> = AV<sub>ss</sub> = 0V, Ta = - 40°C to + 105°C)

Parameter	Pin name	Value			Unit	Remarks
		Min	Typ	Max		
Resolution	-	-	-	12	bit	
Linearity error	-	- 4.5	-	+ 4.5	LSB	AVRH = 2.7V to 5.5V
Differential linearity error	-	-2.5	-	+ 2.5	LSB	
Zero transition voltage	AN0 to AN15	- 20	-	+ 20	mV	
Full transition voltage	AN0 to AN15	- 20	-	+ 20	mV	
Conversion time	-	1.0* <sup>1</sup>	-	-	μs	
Sampling time	Ts	*2	-	-	ns	AV <sub>cc</sub> ≥ 4.5V
		*2	-	-		AV <sub>cc</sub> < 4.5V
Compare clock cycle* <sup>3</sup>	T <sub>ck</sub>	50	-	10000	ns	
State transition time to operation permission	T <sub>stt</sub>	1.0	-	-	μs	
Power supply current (analog + digital)	AV <sub>CC</sub>	-	0.57	0.72	mA	A/D 1unit operation
		-	0.06	20	μA	When A/D stops
Reference power supply current (between AVRH to AVSS)	AVRH	-	1.1	1.96	mA	A/D 1unit operation AVRH=5.5V
		-	0.06	4	μA	When A/D stops
Analog input capacity	C <sub>in</sub>	-	-	12.9	pF	
Analog input resistance	R <sub>in</sub>	-	-	2	kΩ	AV <sub>cc</sub> ≥ 4.5V
				3.8		AV <sub>cc</sub> < 4.5V
Interchannel disparity	-	-	-	4	LSB	
Analog port input current	AN0 to AN15	-	-	5	μA	
Analog input voltage	AN0 to AN15	AV <sub>SS</sub>	-	AVRH	V	
Reference voltage	AVRH	AV <sub>SS</sub>	-	AV <sub>CC</sub>	V	

\*1: Conversion time is the value of sampling time (Ts) + compare time (Tc).

The condition of the minimum conversion time is when HCLK=40MHz, the value of sampling time: 300ns, the value of sampling time: 700ns (AV<sub>cc</sub> ≥ 4.5V)

Ensure that it satisfies the value of sampling time (Ts) and compare clock cycle (T<sub>ck</sub>).

For setting of sampling time and compare clock cycle, see "Chapter: 12-bit A/D Converter" in "FM3 MB9Axxx / MB9Bxxx Series PERIPHERAL MANUAL".

A/D Converter register is set at APB bus clock timing. Sampling and compare clock is set at Base clock (HCLK).

\*2: A necessary sampling time changes by external impedance.

Ensure that it set the sampling time to satisfy (Equation 1)

\*3: Compare time (Tc) is the value of (Equation 2)

# MB9A110 Series

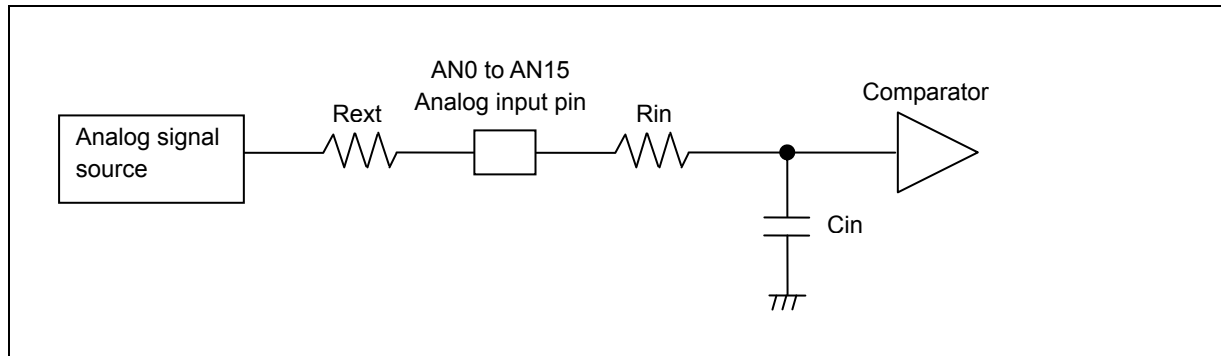

$$\text{(Equation 1) } T_s \geq (R_{in} + R_{ext}) \times C_{in} \times 9$$

$T_s$  : Sampling time

$R_{in}$  : input resistance of A/D =  $2\text{k}\Omega$      $4.5 \leq AVCC \leq 5.5$   
input resistance of A/D =  $3.8\text{k}\Omega$      $2.7 \leq AVCC < 4.5$

$C_{in}$  : input capacity of A/D =  $12.9\text{pF}$      $2.7 \leq AVCC \leq 5.5$

$R_{ext}$  : Output impedance of external circuit

$$\text{(Equation 2) } T_c = T_{ck} \times 14$$

$T_c$  : Compare time

$T_{ck}$  : Compare clock cycle

- Definition of 12-bit A/D Converter Terms

- Resolution : Analog variation that is recognized by an A/D converter.
- Linearity error : Deviation of the line between the zero-transition point (0b000000000000 ←→ 0b000000000001) and the full-scale transition point (0b111111111110 ←→ 0b111111111111) from the actual conversion characteristics.
- Differential linearity error : Deviation from the ideal value of the input voltage that is required to change the output code by 1 LSB.

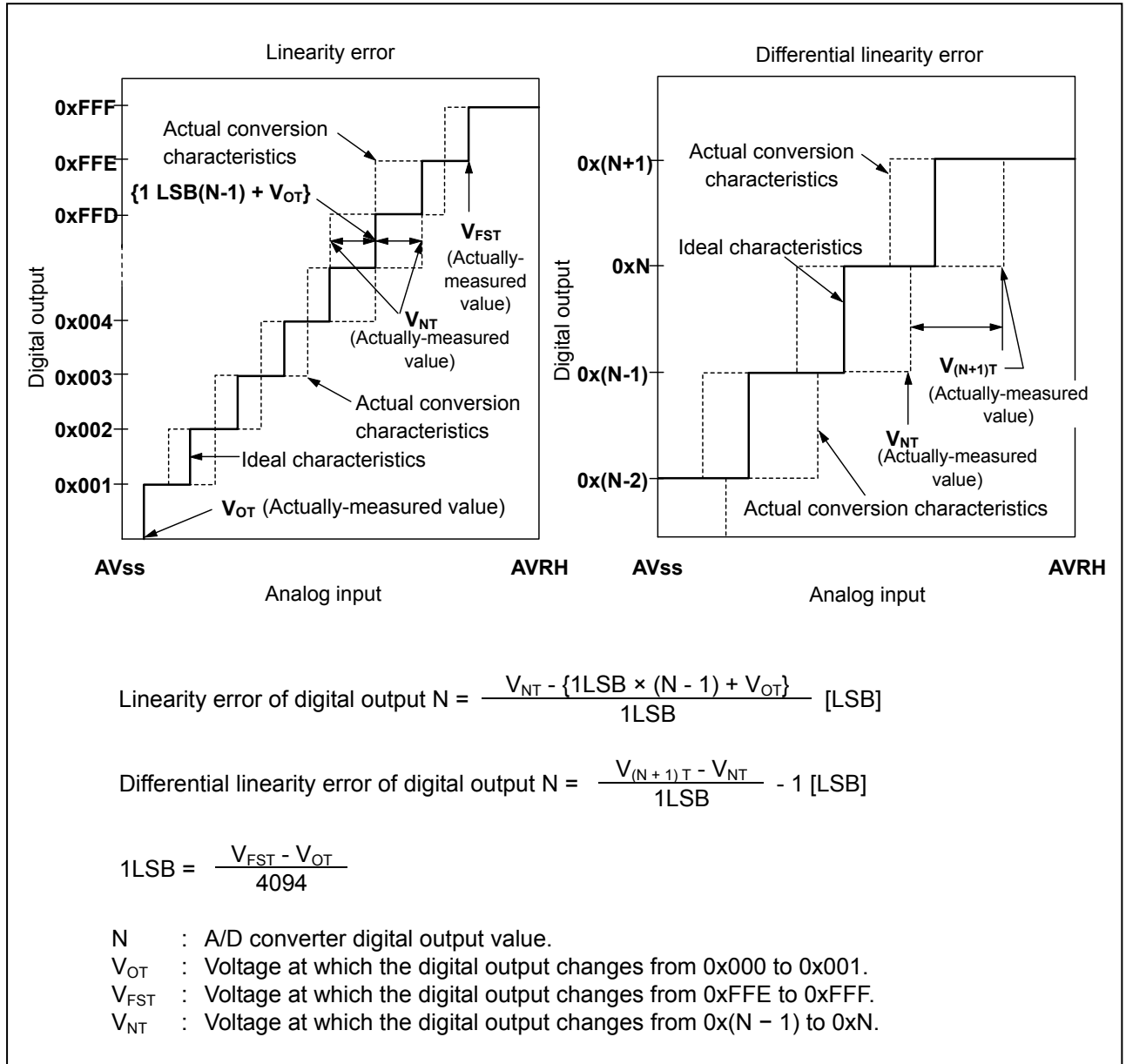

# MB9A110 Series

## ● Low voltage detection characteristics

### 1. Low voltage detection reset

(Ta = - 40°C to + 105°C)

Parameter	Symbol	Conditions	Value			Unit	Remarks
			Min	Typ	Max		
Detected voltage	VDL	-	2.25	2.45	2.65	V	When voltage drops
Released voltage	VDH	-	2.30	2.50	2.70	V	When voltage rises

### 2. Interrupt of low voltage detection

(Ta = - 40°C to + 105°C)

Parameter	Symbol	Conditions	Value			Unit	Remarks
			Min	Typ	Max		
Detected voltage	VDL	SVHI = 0000	2.58	2.8	3.02	V	When voltage drops
Released voltage	VDH		2.67	2.9	3.13	V	When voltage rises
Detected voltage	VDL	SVHI = 0001	2.76	3.0	3.24	V	When voltage drops
Released voltage	VDH		2.85	3.1	3.34	V	When voltage rises
Detected voltage	VDL	SVHI = 0010	2.94	3.2	3.45	V	When voltage drops
Released voltage	VDH		3.04	3.3	3.56	V	When voltage rises
Detected voltage	VDL	SVHI = 0011	3.31	3.6	3.88	V	When voltage drops
Released voltage	VDH		3.40	3.7	3.99	V	When voltage rises
Detected voltage	VDL	SVHI = 0100	3.40	3.7	3.99	V	When voltage drops
Released voltage	VDH		3.50	3.8	4.10	V	When voltage rises
Detected voltage	VDL	SVHI = 0111	3.68	4.0	4.32	V	When voltage drops
Released voltage	VDH		3.77	4.1	4.42	V	When voltage rises
Detected voltage	VDL	SVHI = 1000	3.77	4.1	4.42	V	When voltage drops
Released voltage	VDH		3.86	4.2	4.53	V	When voltage rises
Detected voltage	VDL	SVHI = 1001	3.86	4.2	4.53	V	When voltage drops
Released voltage	VDH		3.96	4.3	4.64	V	When voltage rises
LVD stabilization wait time	T <sub>LVDW</sub>	-	-	-	2240 × t <sub>cycp</sub> *	μs	

\* : t<sub>CYCP</sub> indicates the APB2 clock cycle time.



## ● Flash Memory Write/Erase Characteristics

(V<sub>cc</sub> = 2.7V to 5.5V, Ta = - 40°C to + 105°C)

Parameter		Value			Value	Remarks
		Min	Typ	Max		
Sector erase time	Large Sector	-	0.7	3.3	s	Includes write time prior to internal erase
	Small Sector		0.3	1.1		
Half word (16 bit) write time		-	12	384	μs	Not including system-level overhead time.
Chip erase time	64K/128K/256KByte	-	5.2	23.6	s	Includes write time prior to internal erase
	384K/512KByte		8	38.4	s	

Erase/write cycles and data hold time (targeted value)

Erase/write cycles (cycle)	Data hold time (year)	Remarks
1,000	20 *	
10,000	10 *	
100,000	5 *	

\*: This value comes from the quality and reliability test (using Arrhenius equation to translate high temperature stress test result into normalized value at + 85°C) .

# MB9A110 Series

## ■ ORDERING INFORMATION

Part number	Package
MB9AF111LPMC1	Plastic • LQFP(0.5mm pitch), 64-pin (FPT-64P-M24/M38)
MB9AF112LPMC1	
MB9AF114LPMC1	
MB9AF111LPMC	Plastic • LQFP(0.65mm pitch), 64-pin (FPT-64P-M23/M39)
MB9AF112LPMC	
MB9AF114LPMC	
MB9AF111MPMC	Plastic • LQFP(0.5mm pitch), 80-pin (FPT-80P-M21/M37)
MB9AF112MPMC	
MB9AF114MPMC	
MB9AF115MPMC	
MB9AF116MPMC	
MB9AF111NPMC	Plastic • LQFP(0.5mm pitch), 100-pin (FPT-100P-M20*/M23)
MB9AF112NPMC	
MB9AF114NPMC	
MB9AF115NPMC	
MB9AF116NPMC	
MB9AF111NPF	Plastic • QFP(0.65mm pitch), 100-pin (FPT-100P-M06)
MB9AF112NPF	
MB9AF114NPF	
MB9AF115NPF	
MB9AF116NPF	
MB9AF111NBGL	Plastic • PFPGA(0.8mm pitch), 112-pin (BGA-112P-M04)
MB9AF112NBGL	
MB9AF114NBGL	

\* : ES only

## ■ PACKAGE DIMENSIONS

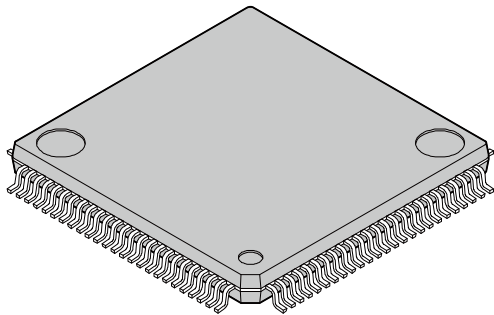
<p>100-pin plastic LQFP</p>  <p>(FPT-100P-M20)</p>	Lead pitch	0.50 mm
	Package width × package length	14.0 mm × 14.0 mm
	Lead shape	Gullwing
	Sealing method	Plastic mold
	Mounting height	1.70 mm Max
	Weight	0.65 g
	Code (Reference)	P-LFQFP100-14×14-0.50

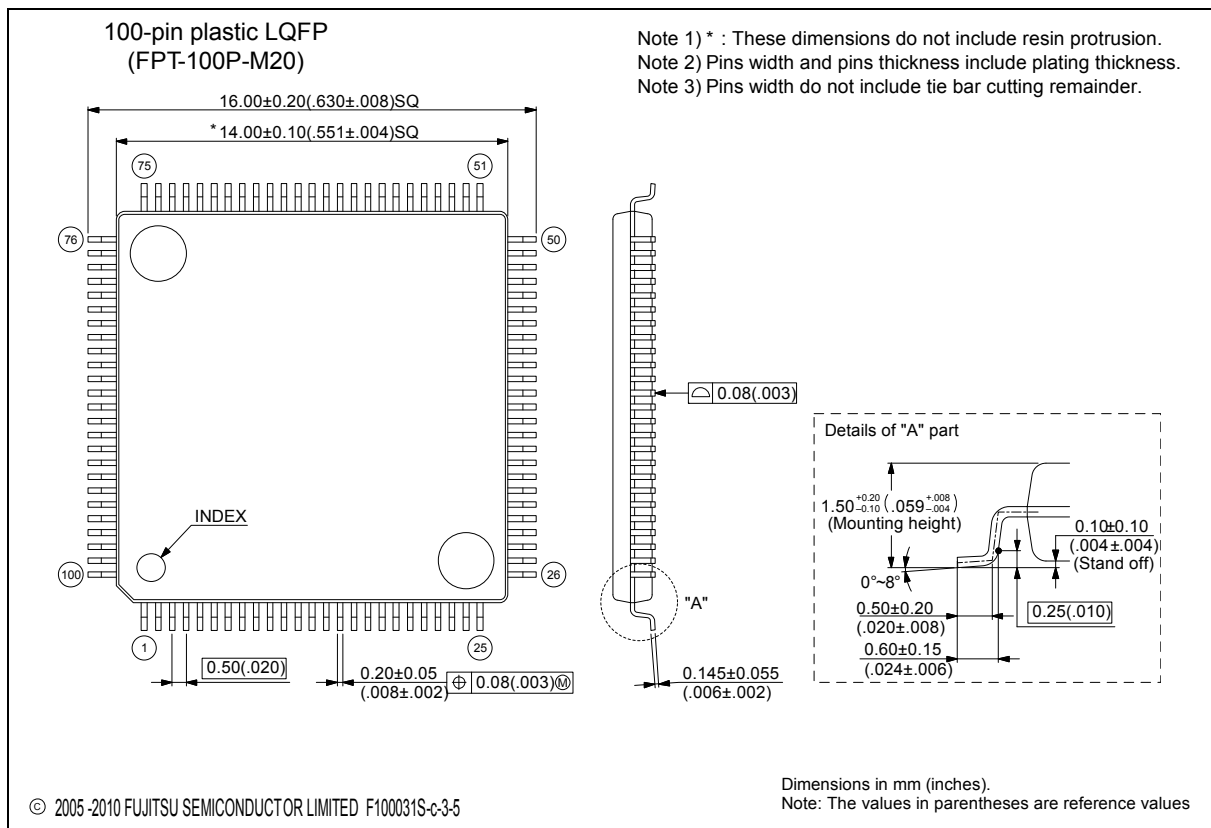

Please check the latest package dimension at the following URL.  
<http://edevice.fujitsu.com/package/en-search/>

# MB9A110 Series

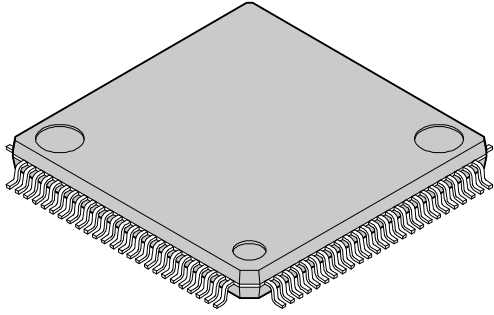
<p>100-pin plastic LQFP</p>  <p>(FPT-100P-M23)</p>	Lead pitch	0.50 mm
	Package width × package length	14.00 mm × 14.00 mm
	Lead shape	Gullwing
	Lead bend direction	Normal bend
	Sealing method	Plastic mold
	Mounting height	1.70 mm MAX
	Weight	0.65 g

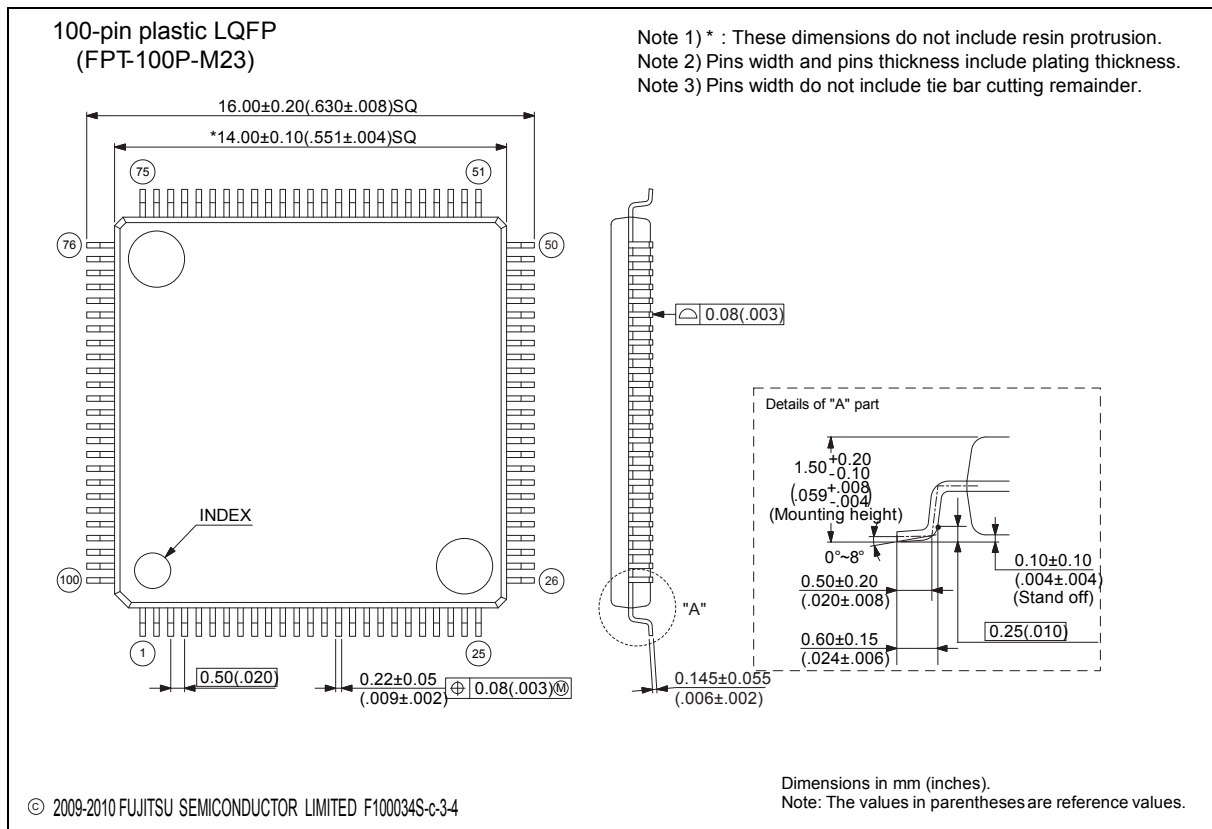

Please check the latest package dimension at the following URL.  
<http://edevice.fujitsu.com/package/en-search/>

# MB9A110 Series

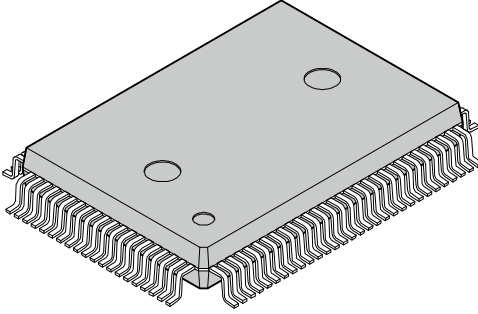
<p>100-pin plastic QFP</p>  <p>(FPT-100P-M06)</p>	Lead pitch	0.65 mm
	Package width × package length	14.00 × 20.00 mm
	Lead shape	Gullwing
	Sealing method	Plastic mold
	Mounting height	3.35 mm MAX
	Code (Reference)	P-QFP100-14×20-0.65

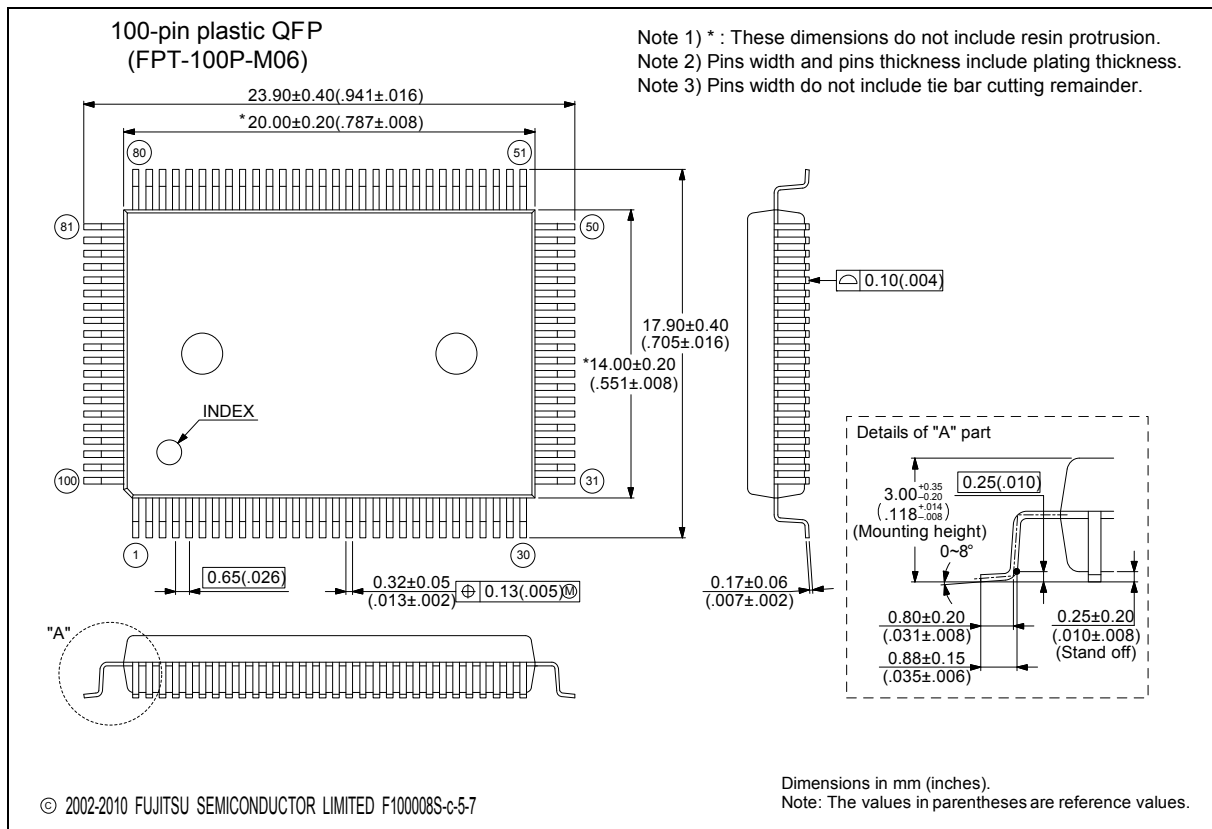

Please check the latest package dimension at the following URL.  
<http://edevic.fujitsu.com/package/en-search/>

# MB9A110 Series

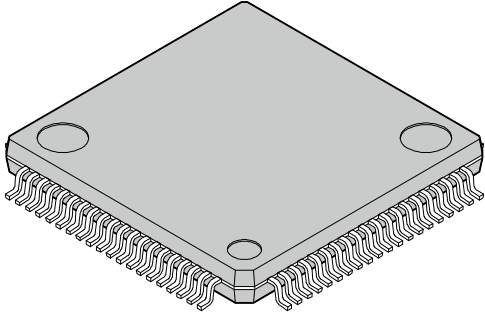
<p>80-pin plastic LQFP</p>  <p>(FPT-80P-M21)</p>	Lead pitch	0.50 mm
	Package width × package length	12 mm × 12 mm
	Lead shape	Gullwing
	Sealing method	Plastic mold
	Mounting height	1.70 mm Max
	Weight	0.47 g
	Code (Reference)	P-LFQFP80-12×12-0.50

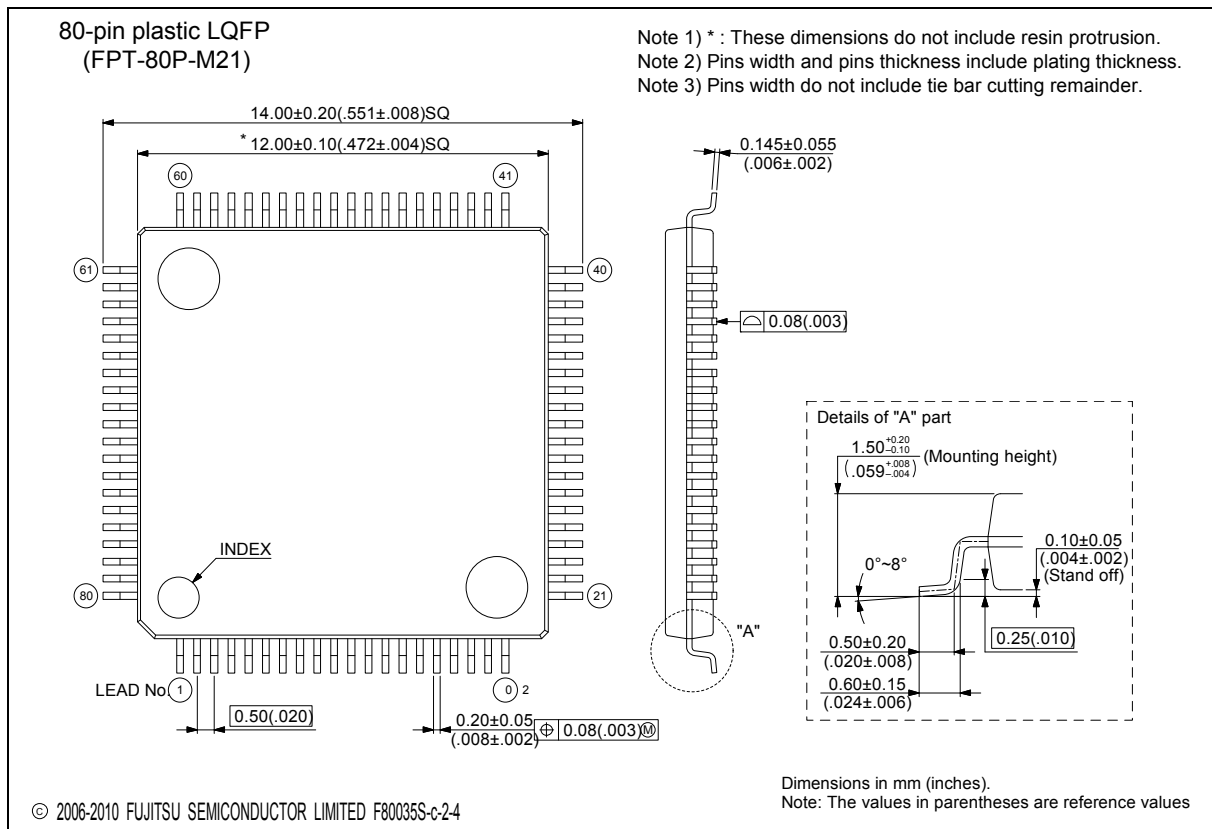

Please check the latest package dimension at the following URL.  
<http://edevic.fujitsu.com/package/en-search/>

# MB9A110 Series

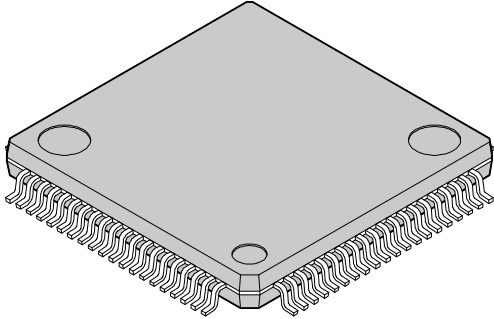
<p>80-pin plastic LQFP</p>  <p>(FPT-80P-M37)</p>	Lead pitch	0.50 mm
	Package width × package length	12.00 mm × 12.00 mm
	Lead shape	Gullwing
	Lead bend direction	Normal bend
	Sealing method	Plastic mold
	Mounting height	1.70 mm MAX
	Weight	0.47 g

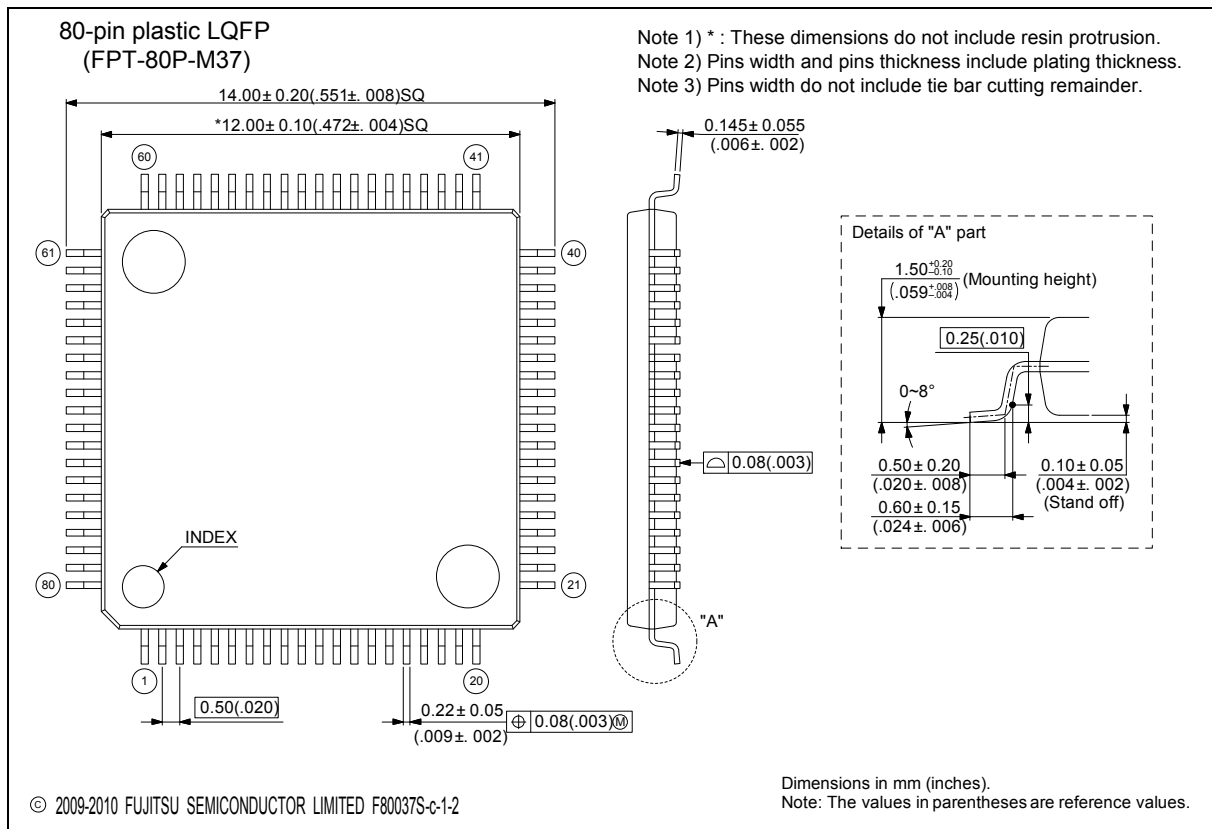

Please check the latest package dimension at the following URL.  
<http://edevice.fujitsu.com/package/en-search/>

# MB9A110 Series

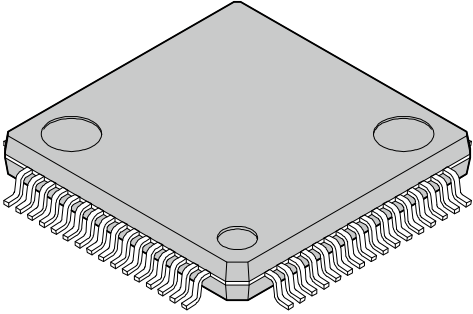
<p>64-pin plastic LQFP</p>  <p>(FPT-64P-M24)</p>	Lead pitch	0.50 mm
	Package width × package length	10.0 × 10.0 mm
	Lead shape	Gullwing
	Sealing method	Plastic mold
	Mounting height	1.70 mm MAX
	Weight	0.32 g
	Code (Reference)	P-LFQFP64-10×10-0.50

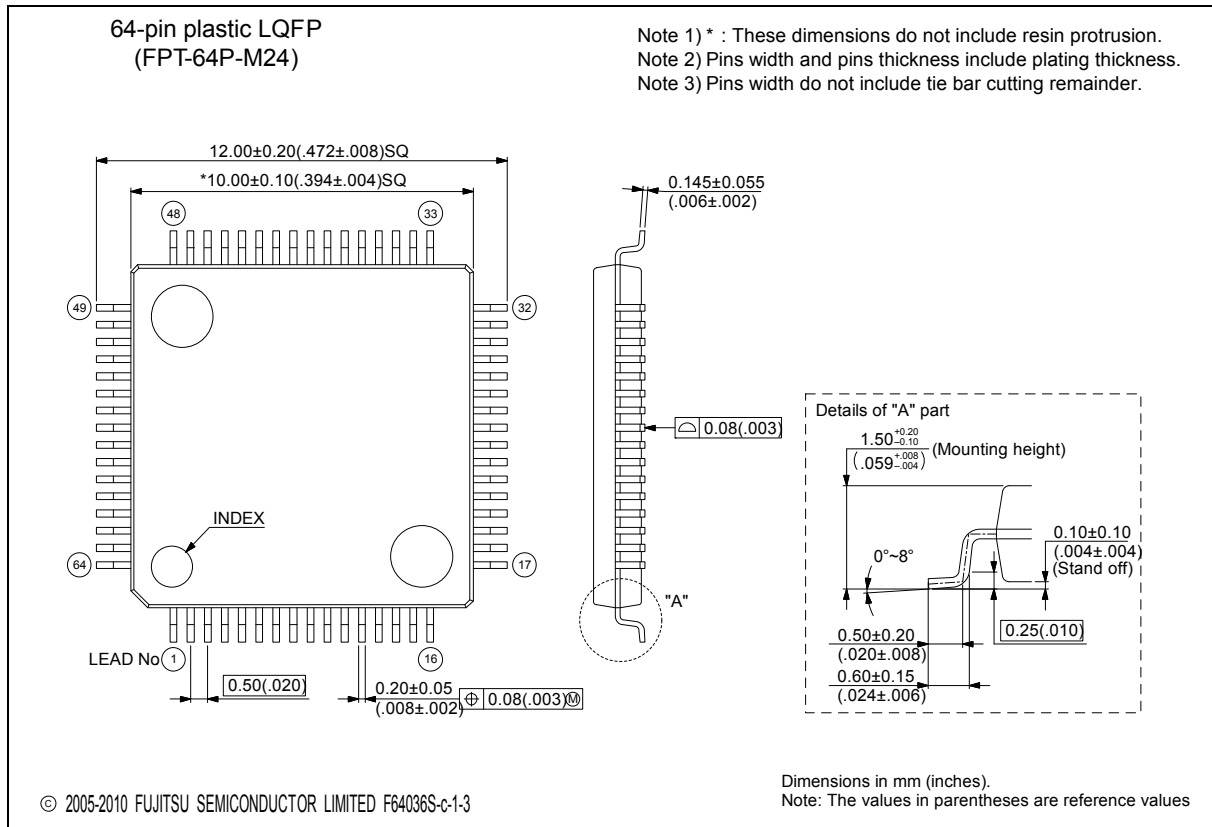

Please check the latest package dimension at the following URL.  
<http://edevice.fujitsu.com/package/en-search/>

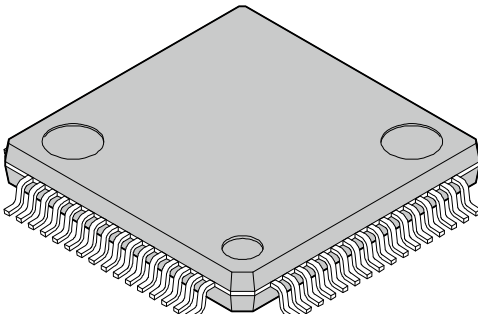

# MB9A110 Series

<p>64-pin plastic LQFP</p>  <p>(FPT-64P-M38)</p>	Lead pitch	0.50 mm
	Package width × package length	10.00 mm × 10.00 mm
	Lead shape	Gullwing
	Lead bend direction	Normal bend
	Sealing method	Plastic mold
	Mounting height	1.70 mm MAX
	Weight	0.32 g

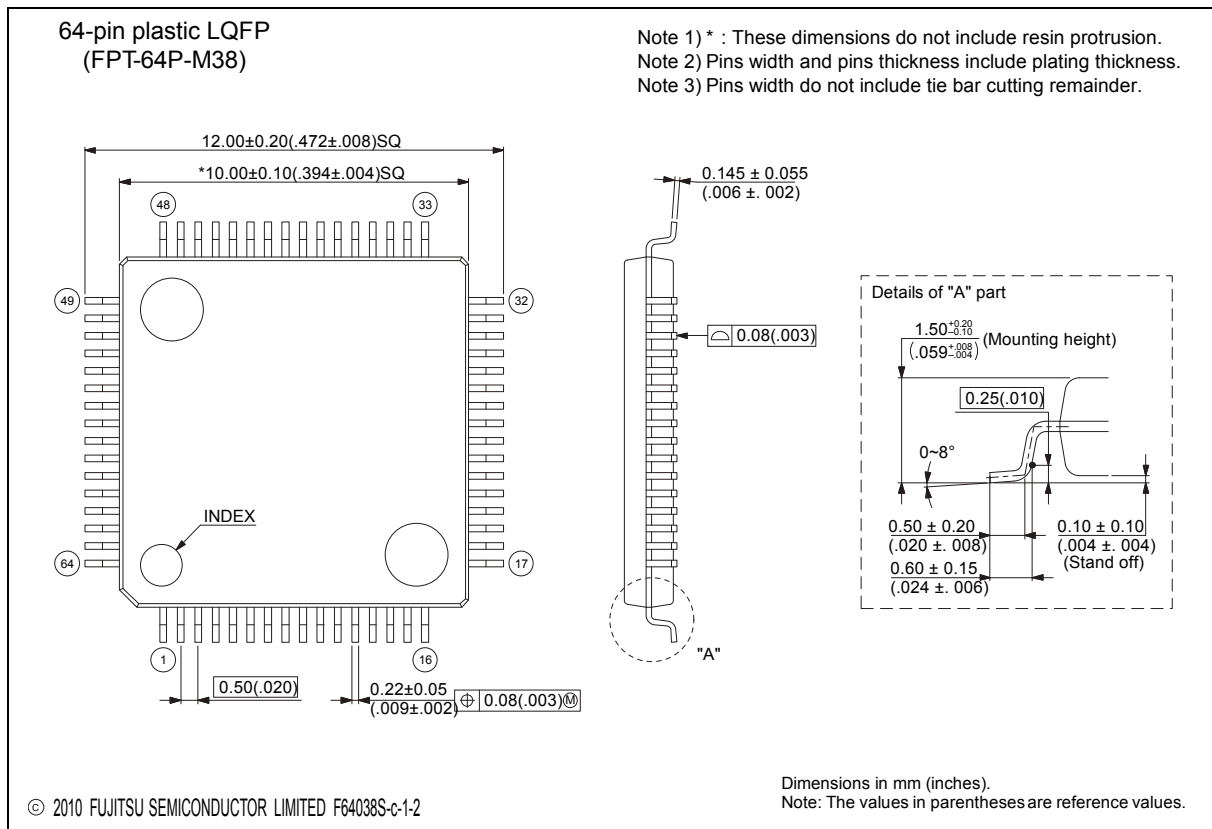

Please check the latest package dimension at the following URL.  
<http://edevice.fujitsu.com/package/en-search/>

# MB9A110 Series

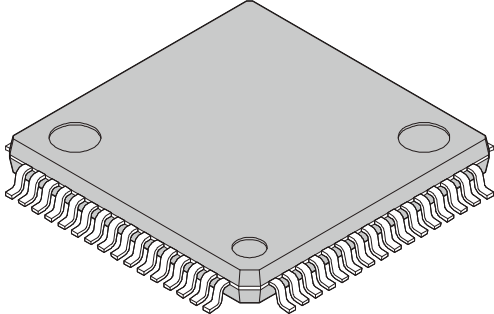
<p>64-pin plastic LQFP</p>  <p>(FPT-64P-M23)</p>	Lead pitch	0.65 mm
	Package width × package length	12.0 × 12.0 mm
	Lead shape	Gullwing
	Sealing method	Plastic mold
	Mounting height	1.70 mm MAX
	Weight	0.47 g
	Code (Reference)	P-LQFP64-12×12-0.65

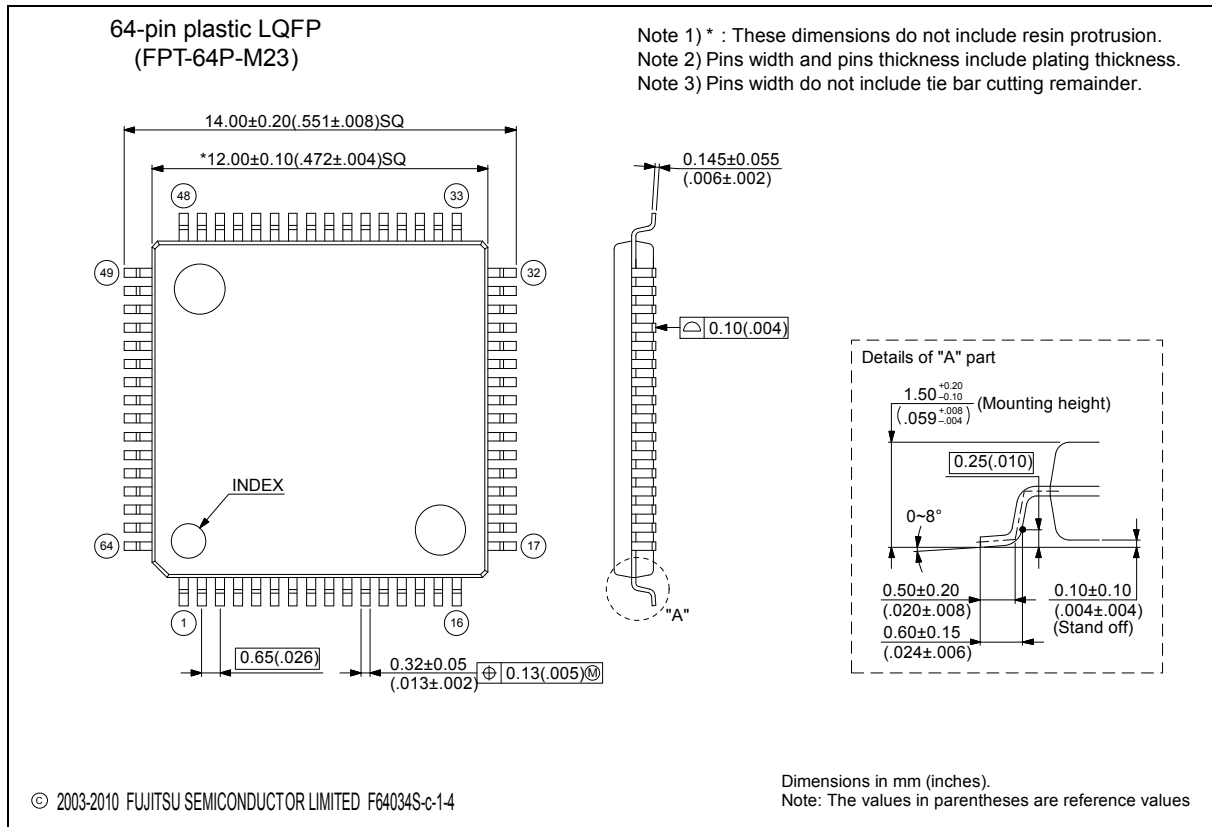

Please check the latest package dimension at the following URL.  
<http://edevice.fujitsu.com/package/en-search/>

# MB9A110 Series

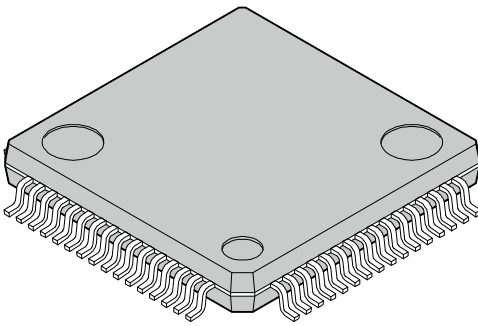
<p>64-pin plastic LQFP</p>  <p>(FPT-64P-M39)</p>	Lead pitch	0.65 mm
	Package width × package length	12.00 mm × 12.00 mm
	Lead shape	Gullwing
	Sealing method	Plastic mold
	Mounting height	1.70 mm MAX
	Weight	0.47 g

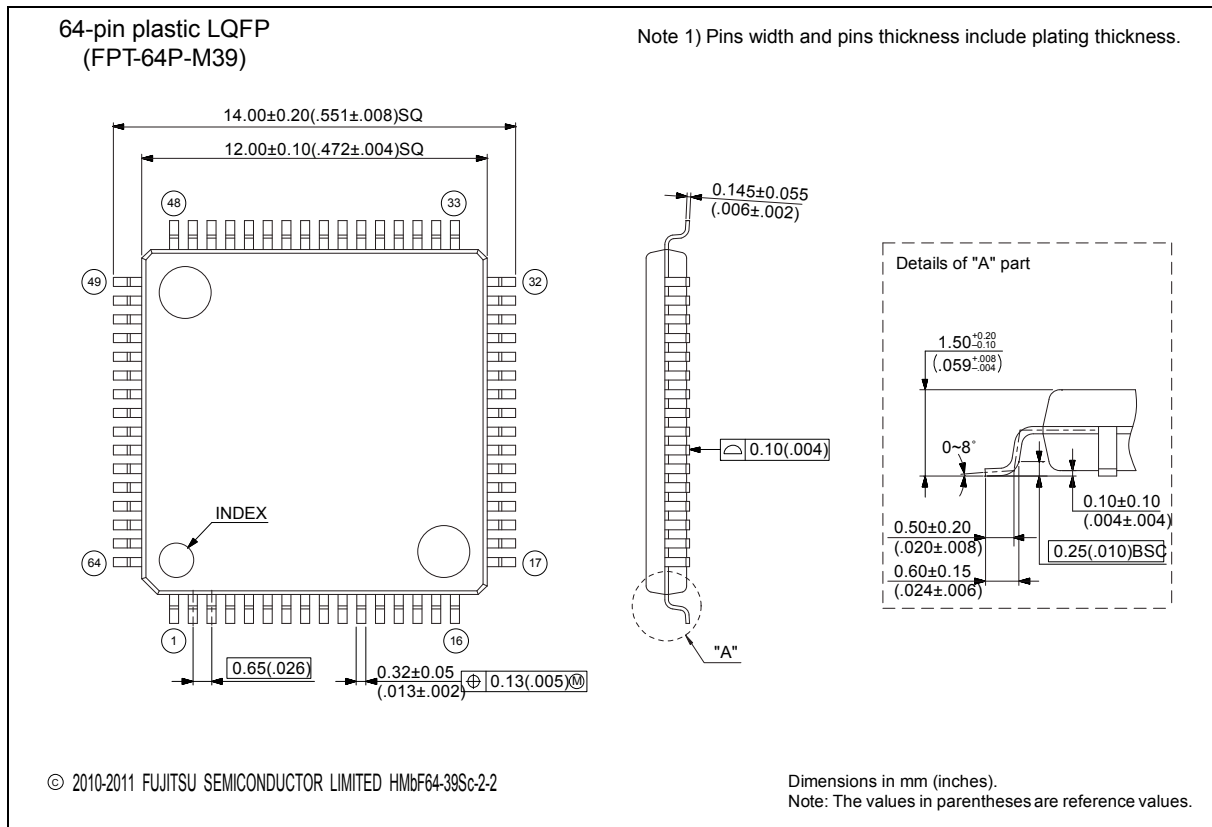

Please check the latest package dimension at the following URL.  
<http://edevice.fujitsu.com/package/en-search/>

# MB9A110 Series

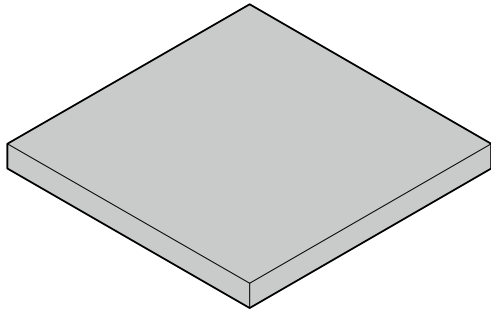
<p>112-ball plastic PFBGA</p>  <p>(BGA-112P-M04)</p>	Ball pitch	0.80 mm
	Package width × package length	10.00 × 10.00 mm
	Lead shape	Soldering ball
	Sealing method	Plastic mold
	Ball size	Ø0.45 mm
	Mounting height	1.45 mm Max.
	Weight	0.22 g

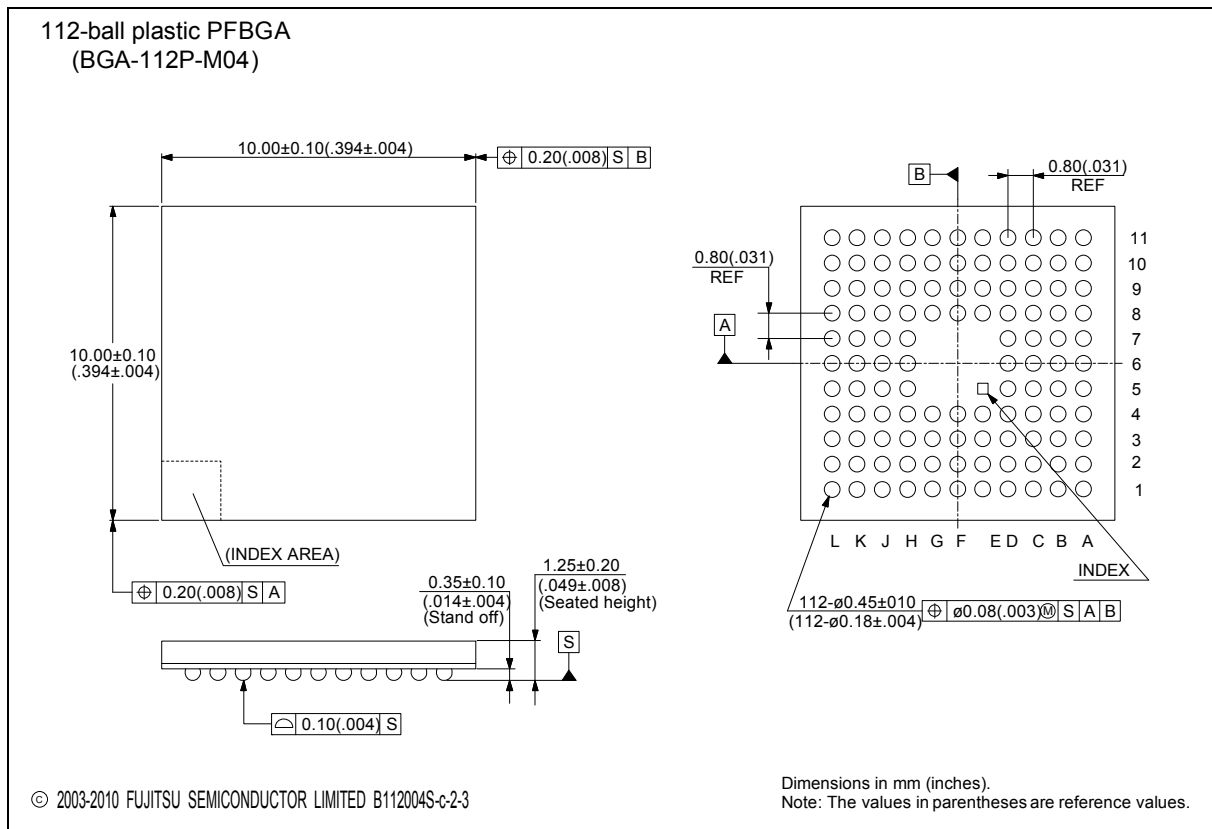

Please check the latest package dimension at the following URL.  
<http://edevice.fujitsu.com/package/en-search/>

## ■ MAJOR CHANGES IN THIS EDITION

A change on a page is indicated by a vertical line drawn on the left side of that page.

Page	Section	Change Results
65, 66	<b>■</b> ELECTRICAL CHARACTERISTICS <b>●</b> DC Characteristics 1. Current rating	Power supply current value was changed. (with "TBD" was changed to the fixed value.)
67	2. Pin Characteristics	Pull-up resistance "R <sub>PU</sub> " value was changed. (with "TBD" was changed to the fixed value.)
69	<b>●</b> AC Characteristics (3) Built-in CR Oscillation Characteristics	Built-in high-speed CR "F <sub>CRH</sub> " value was changed. (with "TBD" was changed to the fixed value.)
70	(4-1/4-2) Operating Conditions of Main PLL	The description of title was changed.
93	<b>●</b> 12bit A/D Converter	State transition time to operation permission "Tstt" value was changed. (Min Value 2.5μs → 1.0μs)
		Power supply current "AVCC, AVRH" value was changed. (with "TBD" was changed to the fixed value.)
97	<b>●</b> Flash Memory Write/Erase Characteristics	Sector/Chip erase time was changed.

**MEMO**

**MEMO**

# MB9A110 Series

## FUJITSU SEMICONDUCTOR LIMITED

Nomura Fudosan Shin-yokohama Bldg. 10-23, Shin-yokohama 2-Chome,  
Kohoku-ku Yokohama Kanagawa 222-0033, Japan

Tel: +81-45-415-5858

<http://jp.fujitsu.com/fsl/en/>

*For further information please contact:*

### North and South America

FUJITSU SEMICONDUCTOR AMERICA, INC.  
1250 E. Arques Avenue, M/S 333  
Sunnyvale, CA 94085-5401, U.S.A.  
Tel: +1-408-737-5600 Fax: +1-408-737-5999  
<http://us.fujitsu.com/micro/>

### Asia Pacific

FUJITSU SEMICONDUCTOR ASIA PTE. LTD.  
151 Lorong Chuan,  
#05-08 New Tech Park 556741 Singapore  
Tel : +65-6281-0770 Fax : +65-6281-0220  
<http://sg.fujitsu.com/semiconductor/>

### Europe

FUJITSU SEMICONDUCTOR EUROPE GmbH  
Pittlerstrasse 47, 63225 Langen, Germany  
Tel: +49-6103-690-0 Fax: +49-6103-690-122  
<http://emea.fujitsu.com/semiconductor/>

### FUJITSU SEMICONDUCTOR SHANGHAI CO., LTD.

Rm. 3102, Bund Center, No.222 Yan An Road (E),  
Shanghai 200002, China  
Tel : +86-21-6146-3688 Fax : +86-21-6335-1605  
<http://cn.fujitsu.com/fss/>

### Korea

FUJITSU SEMICONDUCTOR KOREA LTD.  
902 Kosmo Tower Building, 1002 Daechi-Dong,  
Gangnam-Gu, Seoul 135-280, Republic of Korea  
Tel: +82-2-3484-7100 Fax: +82-2-3484-7111  
<http://kr.fujitsu.com/fsk/>

### FUJITSU SEMICONDUCTOR PACIFIC ASIA LTD.

10/F., World Commerce Centre, 11 Canton Road,  
Tsimshatsui, Kowloon, Hong Kong  
Tel : +852-2377-0226 Fax : +852-2376-3269  
<http://cn.fujitsu.com/fsp/>

Specifications are subject to change without notice. For further information please contact each office.

### All Rights Reserved.

The contents of this document are subject to change without notice.

Customers are advised to consult with sales representatives before ordering.

The information, such as descriptions of function and application circuit examples, in this document are presented solely for the purpose of reference to show examples of operations and uses of FUJITSU SEMICONDUCTOR device; FUJITSU SEMICONDUCTOR does not warrant proper operation of the device with respect to use based on such information. When you develop equipment incorporating the device based on such information, you must assume any responsibility arising out of such use of the information.

FUJITSU SEMICONDUCTOR assumes no liability for any damages whatsoever arising out of the use of the information.

Any information in this document, including descriptions of function and schematic diagrams, shall not be construed as license of the use or exercise of any intellectual property right, such as patent right or copyright, or any other right of FUJITSU SEMICONDUCTOR or any third party or does FUJITSU SEMICONDUCTOR warrant non-infringement of any third-party's intellectual property right or other right by using such information. FUJITSU SEMICONDUCTOR assumes no liability for any infringement of the intellectual property rights or other rights of third parties which would result from the use of information contained herein.

The products described in this document are designed, developed and manufactured as contemplated for general use, including without limitation, ordinary industrial use, general office use, personal use, and household use, but are not designed, developed and manufactured as contemplated (1) for use accompanying fatal risks or dangers that, unless extremely high safety is secured, could have a serious effect to the public, and could lead directly to death, personal injury, severe physical damage or other loss (i.e., nuclear reaction control in nuclear facility, aircraft flight control, air traffic control, mass transport control, medical life support system, missile launch control in weapon system), or (2) for use requiring extremely high reliability (i.e., submersible repeater and artificial satellite).

Please note that FUJITSU SEMICONDUCTOR will not be liable against you and/or any third party for any claims or damages arising in connection with above-mentioned uses of the products.

Any semiconductor devices have an inherent chance of failure. You must protect against injury, damage or loss from such failures by incorporating safety design measures into your facility and equipment such as redundancy, fire protection, and prevention of over-current levels and other abnormal operating conditions.

Exportation/release of any products described in this document may require necessary procedures in accordance with the regulations of the Foreign Exchange and Foreign Trade Control Law of Japan and/or US export control laws.

The company names and brand names herein are the trademarks or registered trademarks of their respective owners.