

max. 1100 m³/h

DC-diagonal fans

Series DV6300 TD 172 Ø x 51 mm



Highlights:

- 3-phase fan drive with high degree of running smoothness
- Very rigid compression curve for high air flow at high back pressure.
- Low operating noise level at high back pressure.
- Standard with PWM control input and speed signal.
- Additional control inputs, alarm and speed signals available on request.

General characteristics:

- Material: aluminium housing, fibreglass-reinforced PBT impeller; housing with grounding lug M4 x 8 (Torx).
- Protected against reverse polarity and locking.
- Connection via single strands AWG 18, UL3266 / AWG22, UL1061 bared and tin-plated.
- Air exhaust over struts. Direction of rotation counter-clockwise, seen on rotor.
- Mass: 960 g.

Nominal data		Air flow	Air flow	Nominal voltage	Voltage range	Sound pressure level	Sound power level	Since sleeve bearings Ball bearings	Power input	Nominal speed	Temperature range	Service life L ₁₀ (40 °C) ebm-papst Standard	Service life L ₁₀ (T _{max}) ebm-papst Standard	Life expectancy L ₁₀ Δ (40 °C)	Curve	Rotor protrusion
Type		m ³ /h	CFM	VDC	VDC	dB(A)	Bel(A)	□ / ■	Watts	RPM	°C	Hours	Hours	Hours		mm
DV 6318 /2TDH4P		1050	617	48	36...72	tbd	8,7	■	300	6 500	-20...+65	62 500 / 35 000	125 000	125 000	1	
DV 6318 /2TDH5P		1100	647	48	36...72	tbd	9,2	■	390	6 800	-20...+65	60 000 / 32 500	115 000	115 000	2	3

Speed control range from 1000 RPM up to maximum nominal speed. Stationary at 0 % PWM, maximum speed at sensor break.

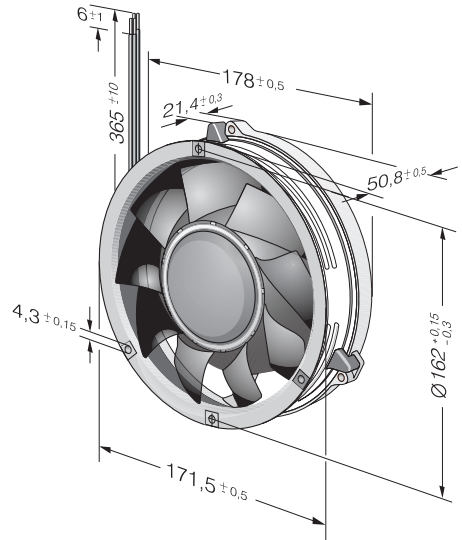
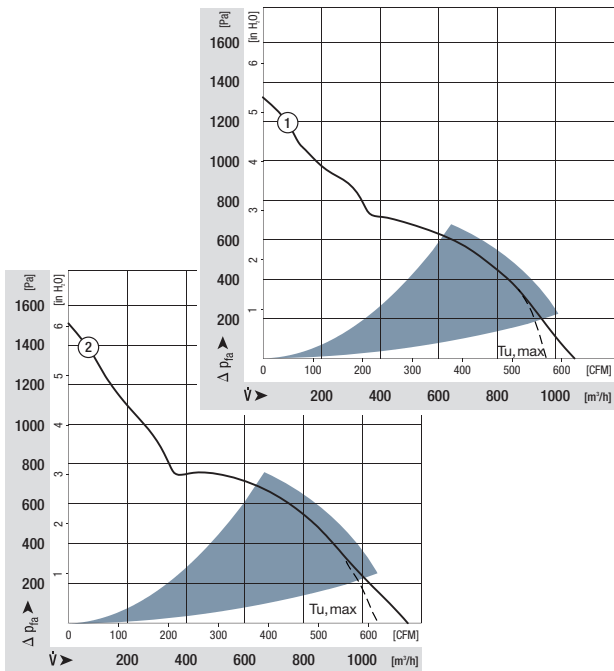

Speed setting with control voltage or PWM



- The control variable is a PWM signal or analogue control voltage.

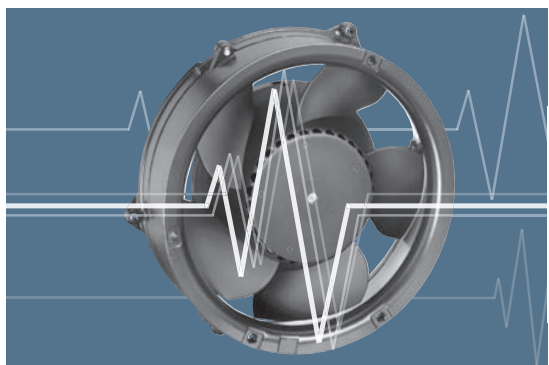

Speed setting via control voltage Type A

- Standard control range 0 ... 5 V.

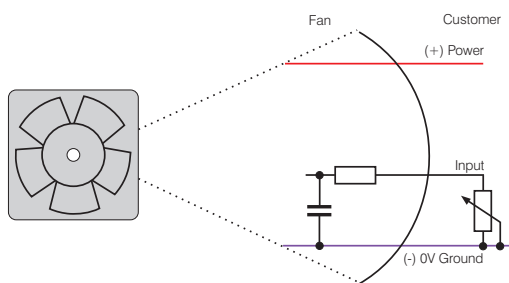

- Optional control range 0 ... 10 V.

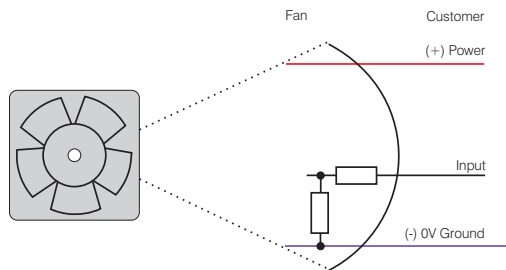

Speed setting via PWM Type P

- Standard PWM signal in 2 versions
 - PWM frequency 2kHz (0-100%), Open collector input
 - 4-Wire interface to Intel specification for 12 VDC fan, PWM frequency 20 kHz, incl. speed signal /2

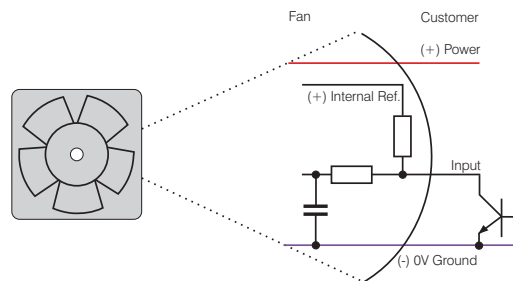

Standard curve P / A

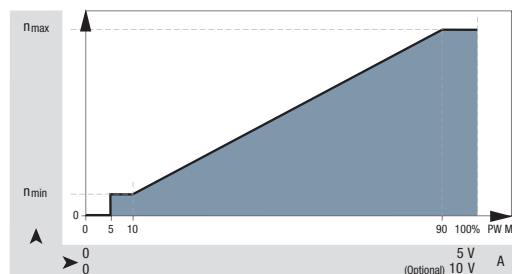

Optional – selectable curve P / A

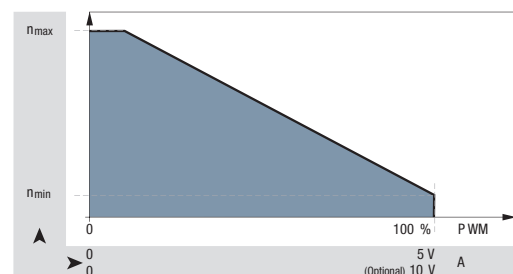

Speed signal /2

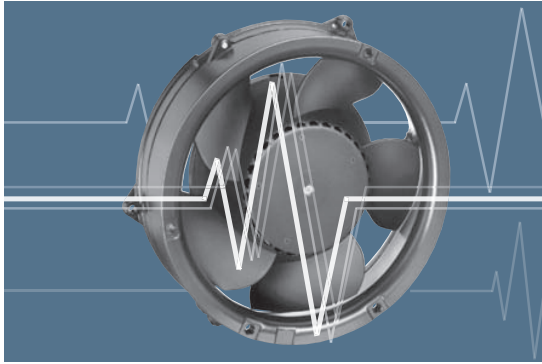

- Speed-proportional rectangular pulse for external speed monitoring of fan motor.
- 2, 3 or 6 pulses per revolution.
- Open collector signal output.
- Extremely wide operating voltage range.
- Easy adaptation to user interface.
- Connection via separate lead.
- The sensor signal also serves as a major comparison variable for setting and maintaining the setpoint speed for interactive or controlled cooling with one or several interconnected fans.

Electrical connection

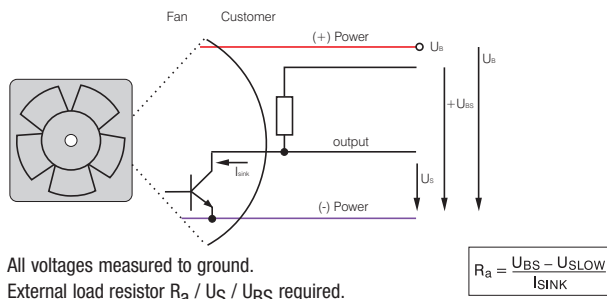

All voltages measured to ground.
External load resistor R_a / U_S / U_{BS} required.

Signal output voltage

Standard signal for all models (exceptions see below)

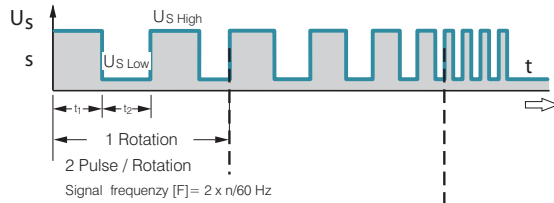

only for 4100 NH7 and NH8

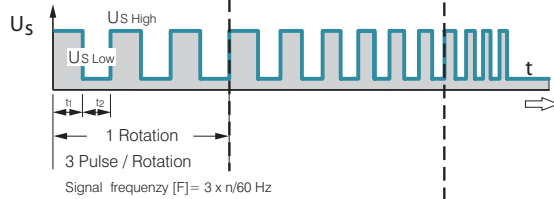

All TD fans. Ex.: 6400 TD

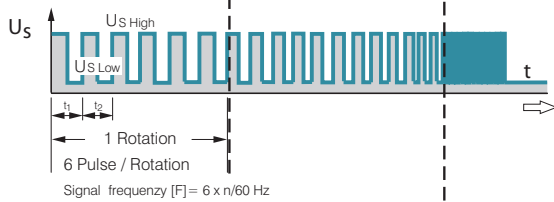

Fan Speed

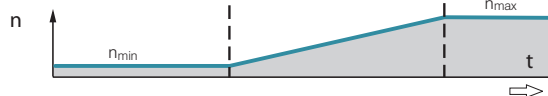

Signal data								
Type	Speed signal $U_{S \text{ Low}}$ VDC	Condition: I_{sink} mA	Speed signal $U_{S \text{ High}}$ VDC	Condition: I_{source} mA	Sensor operating voltage U_{BS} VDC	Perm. sink current $I_{\text{sink max}}$ mA	Pulses per revolution	Fan description
250	≤ 0,4	≤ 2	30	0	≤ 30	2	2	23
400 F	≤ 0,4	1	30	0	≤ 30	≤ 2	2	24
400	≤ 0,4	1	30	0	≤ 30	≤ 2	2	25
400 J	≤ 0,4	2	30	0	≤ 30	≤ 4	2	26
500 F	≤ 0,4	1	30	0	≤ 30	≤ 2	2	27
600 F	≤ 0,4	1	30	0	≤ 30	≤ 2	2	28
620	≤ 0,4	2	30	0	≤ 30	≤ 4	2	29
630 U	≤ 0,4	2	30	0	≤ 30	≤ 4	2	30
600 N	≤ 0,4	2	28	0	≤ 28	≤ 4	2	31
600 J	≤ 0,4	2	30	0	≤ 30	≤ 4	2	33
700 F	≤ 0,4	2	30	0	≤ 30	≤ 4	2	34
8450	≤ 0,4	2	28	0	≤ 28	≤ 4	2	35
8400 N	≤ 0,4	2	28	0	≤ 28	≤ 4	2	36
8400 N VARIOFAN	≤ 0,4	2	30	0	≤ 30	≤ 4	2	37
8300	≤ 0,4	2	30	0	≤ 30	≤ 4	2	38
8200 J	≤ 0,4	2	30	0	≤ 30	≤ 4	2	39
3400 N	≤ 0,4	2	28	0	≤ 28	≤ 4	2	40
3400 N VARIOFAN	≤ 0,4	2	30	0	≤ 30	≤ 4	2	41
3300	≤ 0,4	2	30	0	≤ 30	≤ 4	2	42
3212 J / 3214 J	≤ 0,4	2	30	0	≤ 30	≤ 4	2	43
3218 J	≤ 0,4	2	60	0	≤ 60	≤ 4	2	43
4412 F / 4414 F	≤ 0,4	2	30	0	≤ 30	≤ 4	2	44
4418 F	≤ 0,4	2	60	0	≤ 60	≤ 4	2	44
4400 FN	≤ 0,4	2	30	0	≤ 30	≤ 4	2	45
4312 / 4314	≤ 0,4	2	30	0	≤ 30	≤ 4	2	46
4318	≤ 0,4	2	60	0	≤ 60	≤ 4	2	46
4312 / 4314 VARIOFAN	≤ 0,4	2	30	0	≤ 30	≤ 4	2	47
4318 VARIOFAN	≤ 0,4	2	60	0	≤ 60	≤ 4	2	47
4400	≤ 0,4	2	30	0	≤ 30	≤ 4	2	48
4100 N	≤ 0,4	2	30	0	≤ 30	≤ 4	2	49
4100 NHH...NH6	≤ 0,4	2	≤ 60	0	≤ 60	≤ 10	2	50
4100 NH7...NH8	≤ 0,4	2	≤ 60	0	≤ 60	≤ 20	3	51
DV 4100	≤ 0,4	2	30	0	≤ 30	≤ 4	2	52
5200 N	≤ 0,4	2	30	0	≤ 30	≤ 4	2	53

Available on request:

- Electrically isolated sensor and signal circuit.
- Varying voltage potentials for power and logic circuit.

Signal data	Speed signal $U_{S, Low}$	Condition: i_{sink}	Speed signal $U_{S, High}$	Condition: i_{source}	Sensor operating voltage U_{BS}	Perm. sink current $i_{sink, max}$	Pulses per revolution	Fan description
Type	VDC	mA	VDC	mA	VDC	mA	Page	
DV 5200	≤ 0,4	2	30	0	≤ 30	≤ 4	2	54
5112 N	≤ 0,4	2	15	0	≤ 5	≤ 20	2	55
5114 N / 5118 N	≤ 0,4	2	60	0	≤ 60	≤ 20	2	55
5300	≤ 0,4	2	≤ 72	0	≤ 72	≤ 4	2	56
5300 TD	≤ 0,4	2	72	0	≤ 72	≤ 20	6	57
7112 N / 7118 N	≤ 0,4	2	60	0	≤ 60	≤ 20	2	58
7114 N	≤ 0,4	2	30	0	≤ 30	≤ 20	2	58
7200 N	≤ 0,4	2	15	0	≤ 15	≤ 20	2	59
6300	≤ 0,4	2	≤ 72	0	≤ 72	≤ 20	2	61
6300 TD	≤ 0,4	2	72	0	≤ 72	≤ 20	6	62
DV 6200	≤ 0,4	2	30	0	≤ 60	≤ 20	2	64
6400	≤ 0,4	2	60	0	≤ 60	≤ 20	2	66
2200 FTD	≤ 0,4	2	72	0	≤ 72	≤ 20	6	70
RL 48	≤ 0,4	2	3	0	≤ 30	≤ 4	2	81
RL 65	≤ 0,4	2	30	0	≤ 30	≤ 4	2	82
RL 90 N	≤ 0,4	2	30	0	≤ 30	≤ 4	2	83
RLF 100	≤ 0,4	2	30	0	≤ 30	≤ 4	2	84
RG 90 N	≤ 0,4	2	30	0	≤ 30	≤ 4	2	85
RG 125 N	≤ 0,4	2	30	0	≤ 30	≤ 4	2	86
RG 160 N	≤ 0,4	2	30	0	≤ 30	≤ 20	2	87
RG 160 TD	≤ 0,4	2	60	0	≤ 60	≤ 20	6	88
RG 190 TD	≤ 0,4	2	72	0	≤ 72	≤ 20	6	89
RG 220 TD	≤ 0,4	2	72	0	≤ 72	≤ 20	6	90
RG 225 TD	≤ 0,4	2	72	0	≤ 72	≤ 20	6	91
RET 97 TD	≤ 0,4	2	72	0	≤ 72	≤ 20	6	92
REF 100	≤ 0,4	2	30	0	≤ 30	≤ 4	2	93
RER 120 TD	≤ 0,4	2	72	0	≤ 72	≤ 20	6	95
RER 133 TD	≤ 0,4	2	72	0	≤ 72	≤ 20	6	97
RER 160 TD	≤ 0,4	2	60	0	≤ 60	≤ 20	6	99
REF 175 TD	≤ 0,4	2	72	0	≤ 72	≤ 20	6	100
RER 175 TD	≤ 0,4	2	72	0	≤ 72	≤ 20	6	101
RER 190 TD	≤ 0,4	2	72	0	≤ 72	≤ 20	6	102
RER 220 TD	≤ 0,4	2	72	0	≤ 72	≤ 20	6	103
RER 225 TD	≤ 0,4	2	72	0	≤ 72	≤ 20	6	104

Attention:

With these fan options, deviations in regard to temperature range, voltage range and power consumption are possible compared with standard fan data.