

Modular Stacking Tote Box

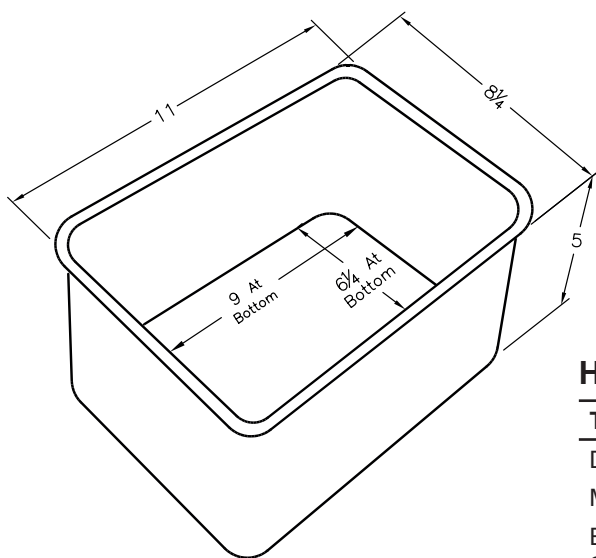

Notes:

Material : Static Dissipative High Density Polyethylene
 Colour : Blue



Dimensions : Inches

High Density Polyethylene Specifications:

Typical Property	Test	Units	Value
Density	ASTM D 1505-57T	lbs/ft ³	60
Melt Index	ASTM D1238-57T	g/10 min.	0.3
Environmental Stress			
Cracking Resistance	ASTM D 1693-59T	°F ₅₀ hrs.	15-20
Tensile Strength	ASTM D 638-58T	2 in./min., psi	4400
Elongation	ASTM D 638-58T	2 in./min., %	>600
Impact Strength	ASTM D 256-56	ft.lbs./in. notch	14
Brittleness Temp	ASTM D 746-57T	°F	<-180
Stiffness	ASTM D 747-58T	psi	150,000
Hardness	Shore D	-	68
Burning Rate	ASTM D 635		1 – 1.04

The nominal properties reported herein are typical of the product but do not reflect normal testing variance and therefore should not be used for specifications purposes.

Part Number Table

Description	Part Number
Modular Stacking Tote Box	2820

Important Notice : This data sheet and its contents (the "Information") belong to the members of the Premier Farnell group of companies (the "Group") or are licensed to it. No licence is granted for the use of it other than for information purposes in connection with the products to which it relates. No licence of any intellectual property rights is granted. The Information is subject to change without notice and replaces all data sheets previously supplied. The Information supplied is believed to be accurate but the Group assumes no responsibility for its accuracy or completeness, any error in or omission from it or for any use made of it. Users of this data sheet should check for themselves the Information and the suitability of the products for their purpose and not make any assumptions based on information included or omitted. Liability for loss or damage resulting from any reliance on the Information or use of it (including liability resulting from negligence or where the Group was aware of the possibility of such loss or damage arising) is excluded. This will not operate to limit or restrict the Group's liability for death or personal injury resulting from its negligence. DURATOOL is the registered trademark of the Group. © Premier Farnell plc 2012.

