

ASB-0C SPRING BALANCER

EXPLODED VIEW

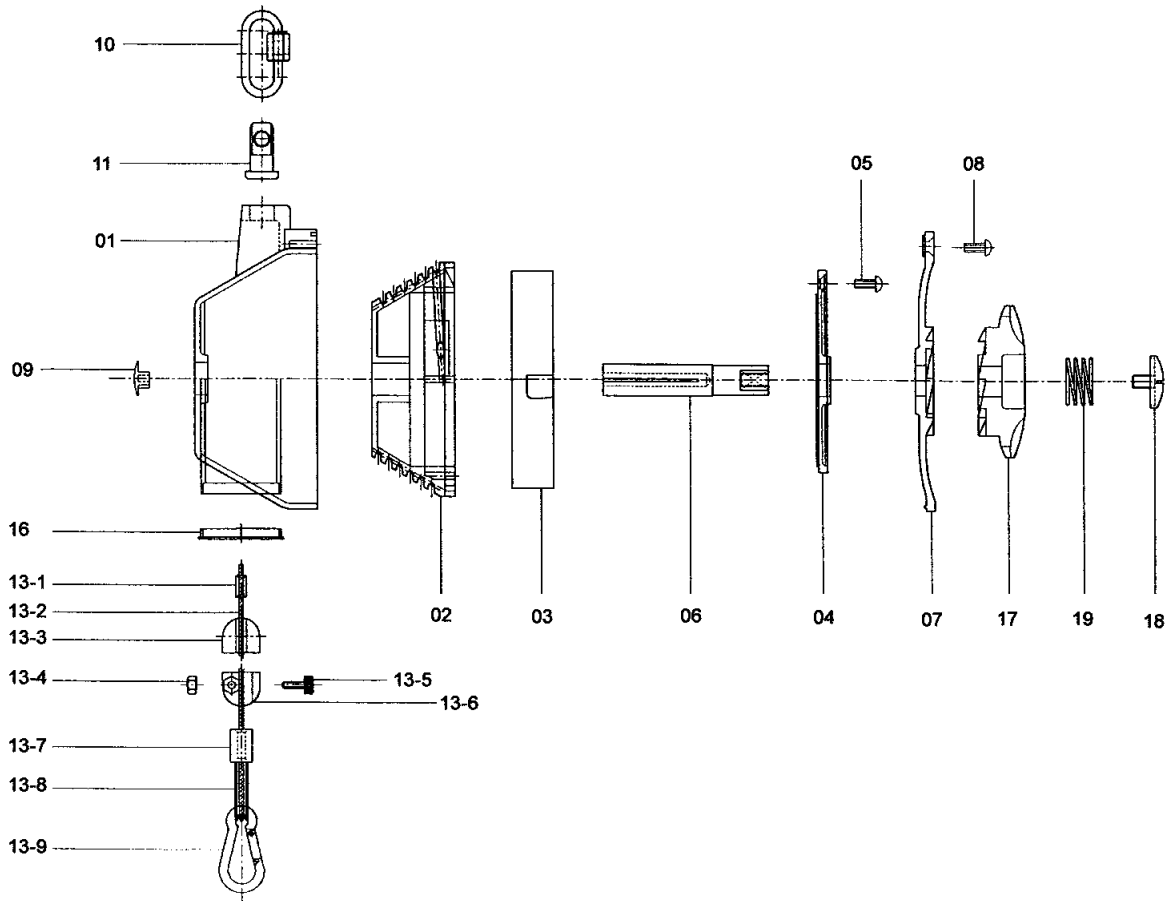

PARTS LIST — FOR REFERENCE ONLY

Index Number	Description	Part Number	Qty.
1	CASE	00001-C	1
2	DRUM	00002-C	1
3	SPIRAL SPRING	00003-C	1
4	DRUM COVER	00004-C	1
5	INTERNAL SCREW	SW412	3
6	SPINDLE	00005	1
7	COVER	00006-C	1
8	EXTERNAL SCREW	SW412	3
9	CAP	00007	1
10	MAIN HANGER	00008	1
11	UPPER SWIVEL	00009	1
13	CABLE SET	00011S	1
13 - 1	LOCK (1)	-	1
13 - 2	CABLE)	-	1
13 - 3	SHOCK ABSORBER)	-	1
13 - 4	NUT)	-	1
13 - 5	BOLT)	-	1

Index Number	Description	Part Number	Qty.
13 - 6	CABLE STOP)	-	1
13 - 7	LOCK (11))	-	1
13 - 8	THIMBLE)	-	1
13 - 9	TOOL CLIP)	-	1
16	CASE INSERT	00001-1	1
17	EXTERNAL KNOB	00014-C	1
18	KNOB BOLT	00015	1
19	SPRING	00016	1

NOTES

See ASB-0C Spring Balancer manual for complete operating and safety instructions before use.



When ordering spare parts, please specify tool type, part number and description.

Distributed by: All-Spec Industries
 www.all-spec.com
 Phone: 800-537-0351

AIMCO offers a complete line of Tool Support products.