

Instructions:

- Before using the digital caliper for the first time, wipe clean the surface with dry and clean soft cloth
- Always keep the digital caliper clean and dry
- Never apply electrical voltage onto any part of the digital caliper
- Do not engrave the caliper with electrical engraving pen
- Remove battery if the caliper is not used for prolong period

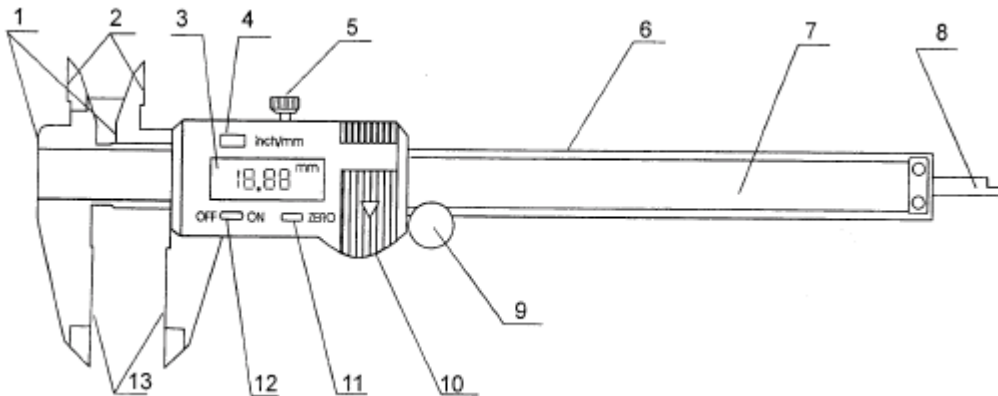

Nomenclature

1. Step measuring faces
2. Inside measuring faces
3. LCD display
4. Inch / mm conversion switch
5. Slider clamp screw
6. Beam
7. Scale
8. Depth measuring blade
9. Thumb roller
10. Battery compartment lid
11. Zero switch
12. Power ON / OFF switch
13. Outside measuring faces

Operation

1. Preparation

- a. Wipe clean the measuring surface of the digital caliper with dry and clean soft cloth
- b. Loosen the locking screw and check if all the buttons, switches and LCD display respond well

2. Basic Methods of Measuring

- a. Make sure the slider clamp screw (5) is loosened
- b. Press the "ON" button (12) to switch on the unit
- c. Press the "inch / mm" button (4) to select the unit of measurement
- d. Close the measuring jaws and press the "ZERO" button (11) to reset the display to zero
- e. Use one of the following measurement methods to take measurement

To Measure Steps

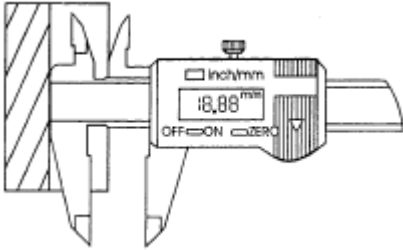

To Measure External Dimensions

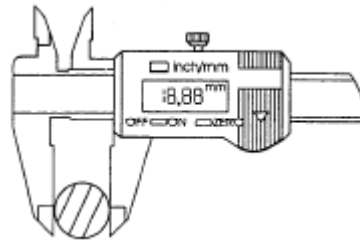

To Measure Internal Dimensions

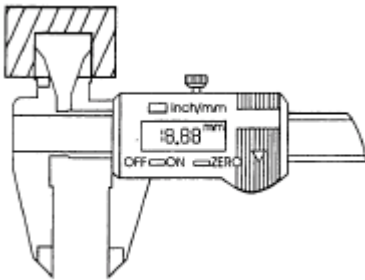

To Measure Depths

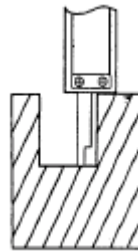

Battery Replacement

Remove the battery compartment lid (10) in the direction of the arrow and replace the battery with the positive side facing out. Close the compartment lid

Troubleshooting

Symptom	Possible causes	Measure
Frozen display	Accidental trouble in circuit	Remove the battery and put back after one minute
Flashing digits	Battery is weak	Replace the battery
No display on LCD	1. Dead battery 2. Poor battery contact	1. Replace the battery 2. Clean and adjust the battery contact point in the battery compartment

Technical Specifications

Display	: LCD Type
Measuring Speed	: ≤1.5 m / seconds or 60 inches / seconds
Measuring Range	: 0 to 150 mm / 0 to 6 inches
Power	: One 1.5 V button cell (Type Sr44)
Storage Temperature	: 0°C to 50°C / 32°F to 122°F
Working Environment	: 5°C to 40°C / 41°F to 104°F (less than 80% Relative Humidity)
Resolution	: 0.01 mm / 0.0005 inches
Accuracy	: +0.02 mm / ±0.001 inches (<100 mm) : ±0.03 mm / ±0.001 inches (100 to 150 mm)

Part Number Table

Description	Part Number
Digital Caliper, 150 mm	D00352

Important Notice : This data sheet and its contents (the "Information") belong to the members of the Premier Farnell group of companies (the "Group") or are licensed to it. No licence is granted for the use of it other than for information purposes in connection with the products to which it relates. No licence of any intellectual property rights is granted. The Information is subject to change without notice and replaces all data sheets previously supplied. The Information supplied is believed to be accurate but the Group assumes no responsibility for its accuracy or completeness, any error in or omission from it or for any use made of it. Users of this data sheet should check for themselves the Information and the suitability of the products for their purpose and not make any assumptions based on information included or omitted. Liability for loss or damage resulting from any reliance on the Information or use of it (including liability resulting from negligence or where the Group was aware of the possibility of such loss or damage arising) is excluded. This will not operate to limit or restrict the Group's liability for death or personal injury resulting from its negligence. DURATOOL is the registered trademark of the Group. © Premier Farnell plc 2012.