

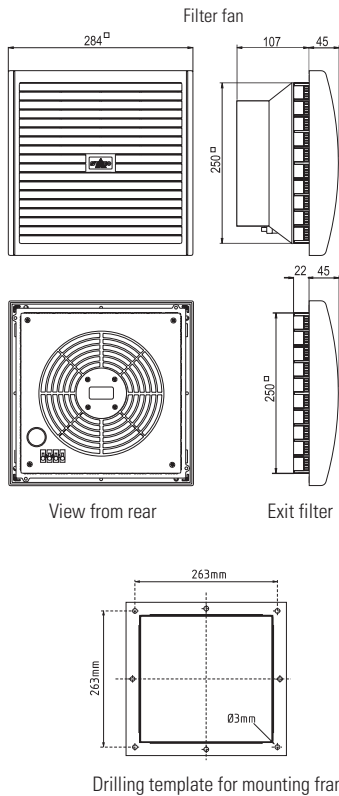

- **High through-flow air volume**
- **Functional design**
- **Time-saving installation**
- **Weather proof and UV resistant**

Filter fans are used to provide an optimum climate in enclosures. The interior temperature of an enclosure can be reduced by channelling cooler filtered outside air into the enclosure thus expelling heated internal air. The resulting air flow prevents formation of localised hot pocket and protects the electronic components from overheating. The high-performance axial fan provides high air circulation. The plastic used for the hood of this filter fan series is highly weather proof and UV light resistant.



Technical Data	
Axial fan, ball bearing	service life min. 50,000h at 25°C/77°F (65% RH) fan body aluminium, rotor metal
Connection	3-pole clamp for 2.5mm ² , clamping torque 0.8Nm max.
Casing (filter fan and exit filter)	Plastic according to UL94 V-0, light grey
Hood (filter fan and exit filter)	Plastic according to UL94 V-0, light grey; weather proof and UV light resistant according to UL746C (f1)
Mounting frame	with double-sided industrial adhesive band for fixing to the outside of enclosure; certain operating circumstances can make the additional use of screws necessary (see drilling template); included in the delivery of the filter fans is a template for the enclosure cut-out
Filter mat	G4 acc. to DIN EN 779, filtering degree 94%
Filter material	synthetic fibre with progressive construction, temperature resistant to 100°C, self-extinguishing class F1; moisture resistant to 100% RH, reusable – cleaning by washing or vacuuming
Operating / Storage temperature	-25 to +70°C (-13 to +158°F)
Operating / Storage humidity	max. 90% RH (non-condensing)
Prot. Type / Protection class	IP55 / I (earthed)

Filter Fan FF 018 Series

Art. No.	Operating voltage	Air volume, free flow	Air volume with exit filter	Current consumption	Power consumption	Average noise level (DIN EN ISO 4871)	Depth in enclosure	Enclosure cut-out	Weight (approx.)	Approvals
01805.0-00	230VAC, 50Hz	550m ³ /h	300m ³ /h	300mA	64W	65dB (A)	107mm	250 x 250mm + 0.4	2.7kg	UL File No. E234324
01805.0-01	120VAC, 60Hz	632m ³ /h	345m ³ /h	780mA	85W	65dB (A)	107mm	250 x 250mm + 0.4	2.7kg	UL File No. E234324

Exit Filter EF 118 Series

Art. No.	Depth in enclosure	Enclosure cut-out	Weight (approx.)	Filter mat	Protection type
11803.0-00	22mm	250 x 250mm + 0.4	1.0kg	G4 acc. to DIN EN 779, filtering degree 94%	IP55

Filter Mat FM 086

Filter mat	247 x 247mm
G4 (1 packing unit = 3 pcs.)	Art. No. 08608.0-00

Specifications are subject to change without notice. Errors and omissions excepted. Suitability of this product for its intended use and any associated risks must be determined by the end customer/ buyer in its final application. 02.05.2011

Ventilating