

Kit Description

Rev. 1.1 / August 2011

ZLED7002

ZLED7002KIT-E1 Evaluation Kit





Important Notice

Restrictions in Use

ZMDI's ZLED7002KIT-E1 Evaluation Kit hardware is designed for ZLED7002 demonstration, evaluation, laboratory setup, and module development only. The ZLED7002KIT-E1 Evaluation Kit hardware must not be used for module production or production test setups.

Disclaimer

Zentrum Mikroelektronik Dresden AG (ZMD AG) shall not be liable for any damages arising out of defects resulting from

- (i) delivered hard- and software
- (ii) non-observance of instructions contained in this manual and in any other documentation provided to user, or
- (iii) misuse, abuse, use under abnormal conditions or alteration by anyone other than ZMD AG.

To the extent permitted by law, ZMD AG hereby expressly disclaims and user expressly waives any and all warranties, whether express, implied or statutory, including, without limitation, implied warranties of merchantability and of fitness for a particular purpose, statutory warranty of non-infringement and any other warranty that may arise by reason of usage of trade, custom or course of dealing.

Contents

1	Kit Contents	3
2	Kit Description	3
2.1.	Overview	3
2.2.	Power Supply	3
2.3.	Interface	5
2.4.	Key Features and Benefits of the Demo Board	5
3	Ordering Information	7
4	Related Documents	7

List of Figures

Figure 1	ZLED7002KIT-E1 Evaluation Board (Top and Back view)	4
Figure 2	ZLED7002KIT-E1 Schematic Diagram	6



1 Kit Contents

The ZLED7002KIT-E1 Evaluation Kit consists of the following parts:

- ZLED7002-E1 Evaluation Board
- Kit Disclaimer

The ZLED7002KIT-E1 Demo Kit is fully assembled and ready for immediate operation. This manual is available from <http://www.zmdi.com>.

2 Kit Description

2.1. Overview

The ZLED7002KIT-E1 Evaluation Kit provides a quick and easy method for evaluating the ZLED7002 IC product within its basic application circuit. Reading the *ZLED7002 Data Sheet* before using the Demo Kit is recommended for understanding of the operation of the ZLED7002 IC product and the application circuit on this evaluation board.

The ZLED7002 toggle (side-step) dual-channel LED driver is one of ZMDI's LED driver family ICs. It operates in the lower DC voltage supply range of 2.7V to 5.5V. This unique LED driver is capable to control a MAIN channel and a SUB channel, respectively. Typically, only one of the two channels is active and the ZLED7002 toggles between the channels automatically controlled by the supply voltage level thus the related voltage at the UV (under-voltage protection) pin. The ZLED7002 IC can drive LEDs with a current up to 250mA.

The main features of ZLED7002 driver are:

- The Automatic MAIN channel short-circuit protection switches the output current to the SUB channel if the MAIN LED is shorted
- Under-voltage power supply detection
- Over-temperature protection
- Voltage supply: 2.7V to 5.5V DC

Figure 1 shows the top view of the populated kit PCB.

2.2. Power Supply

The Evaluation Board contains a standard battery holder for 3xAA batteries for power supply. Optional a two pin connector (J3) is present for an external power supply.

Note:

Since the system is not reverse polarity protected, exercise caution when connecting an external power supply or inserting/replacing batteries.

Never use batteries in parallel to an external power supply.

Remove batteries in case the kit is not going to be used for a long time.

ZLED7002

ZLED7002KIT-E1 Evaluation Kit

The Analog Mixed Signal Company



Figure 1 ZLED7002KIT-E1 Evaluation Board (Top and Back view)

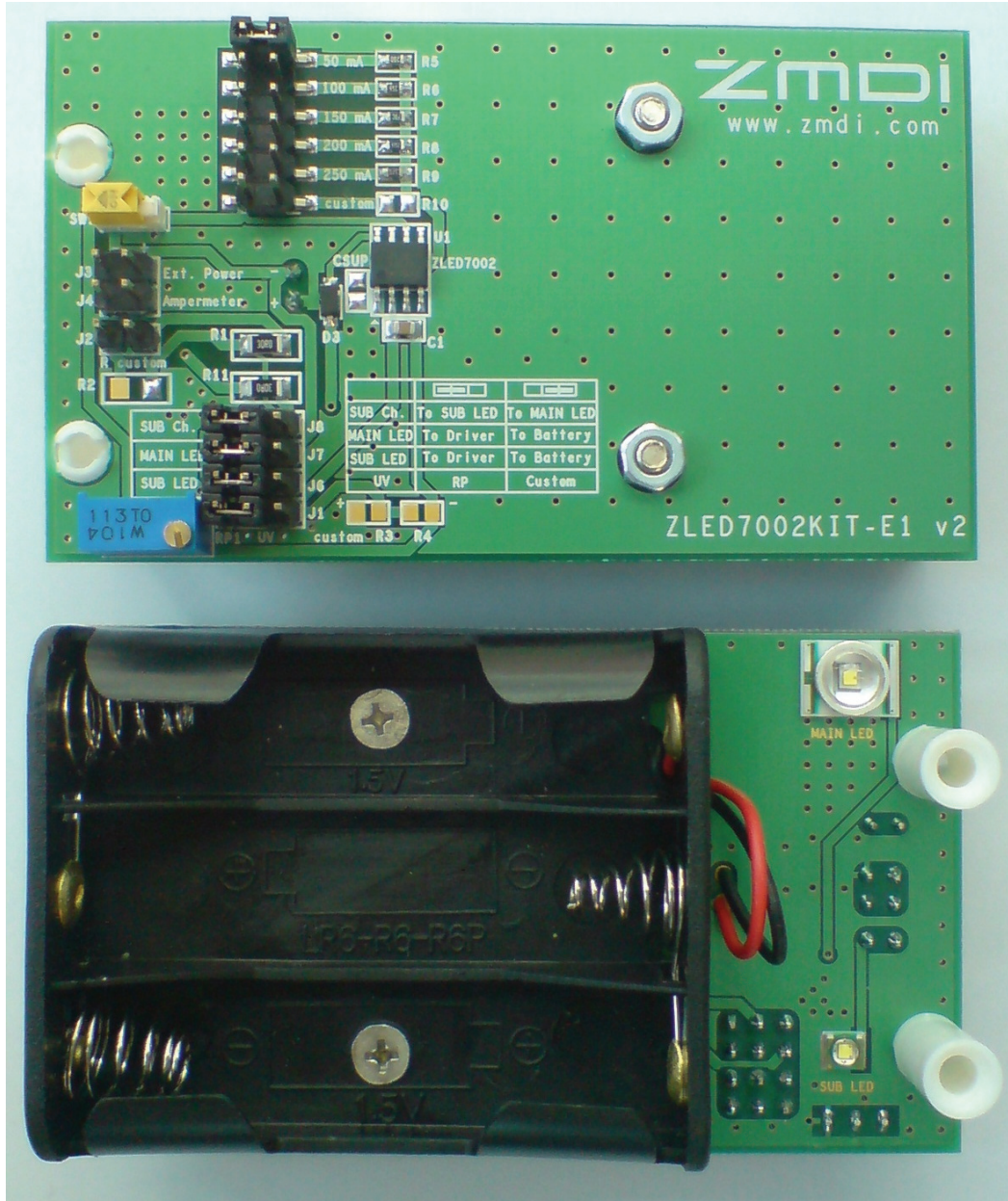



2.3. Interface

The Evaluation Board has two LEDs – MAIN LED and a SUB LED (one LED per IC channel).

Jumper setup for configuring of the ZLED7002 working modes:

J1 – Under Voltage protection level selection. This jumper determines how this level will be defined – by the potentiometer RP1 or by the voltage divider R3 and R4. The resistors R3 and R4 are not populated. The user must choose appropriate values..

J6 – SUB LED working mode. Two options are available – SUB LED to be driven from ZLED7002 or to be directly connected to the supply voltage.

J7 – MAIN LED working mode. Two options are available – MAIN LED to be driven from ZLED7002 or to be directly connected to the supply voltage.

J8 – SUB CHANNEL working mode. Two options are available – SUB CHANNEL drives SUB LED or MAIN LED.

Please refer also to the table printed on the board!

J5 – Current selection jumper. User can chose between five predefined current rates. In addition to that a custom current rate is electable. The desired custom current rate can be set by populating of R10 with an appropriate resistor value (see the Datasheet for details).

J2 - Applying a user selectable resistor to the SUB LED

J3 – Allows connecting of an external power supply

J4 – Allows connecting of an ampere meter

SW1 – main power switch

2.4. Key Features and Benefits of the Demo Board

- Input voltage selection
- Battery or external power supply
- Current selection for MAIN and SUB LEDs
- Under Voltage protection setting
- Current measuring by an optional ampere meter
- Different working modes are selectable

ZLED7002

ZLED7002KIT-E1 Evaluation Kit



The Analog Mixed Signal Company



Figure 2 ZLED7002KIT-E1 Schematic Diagram

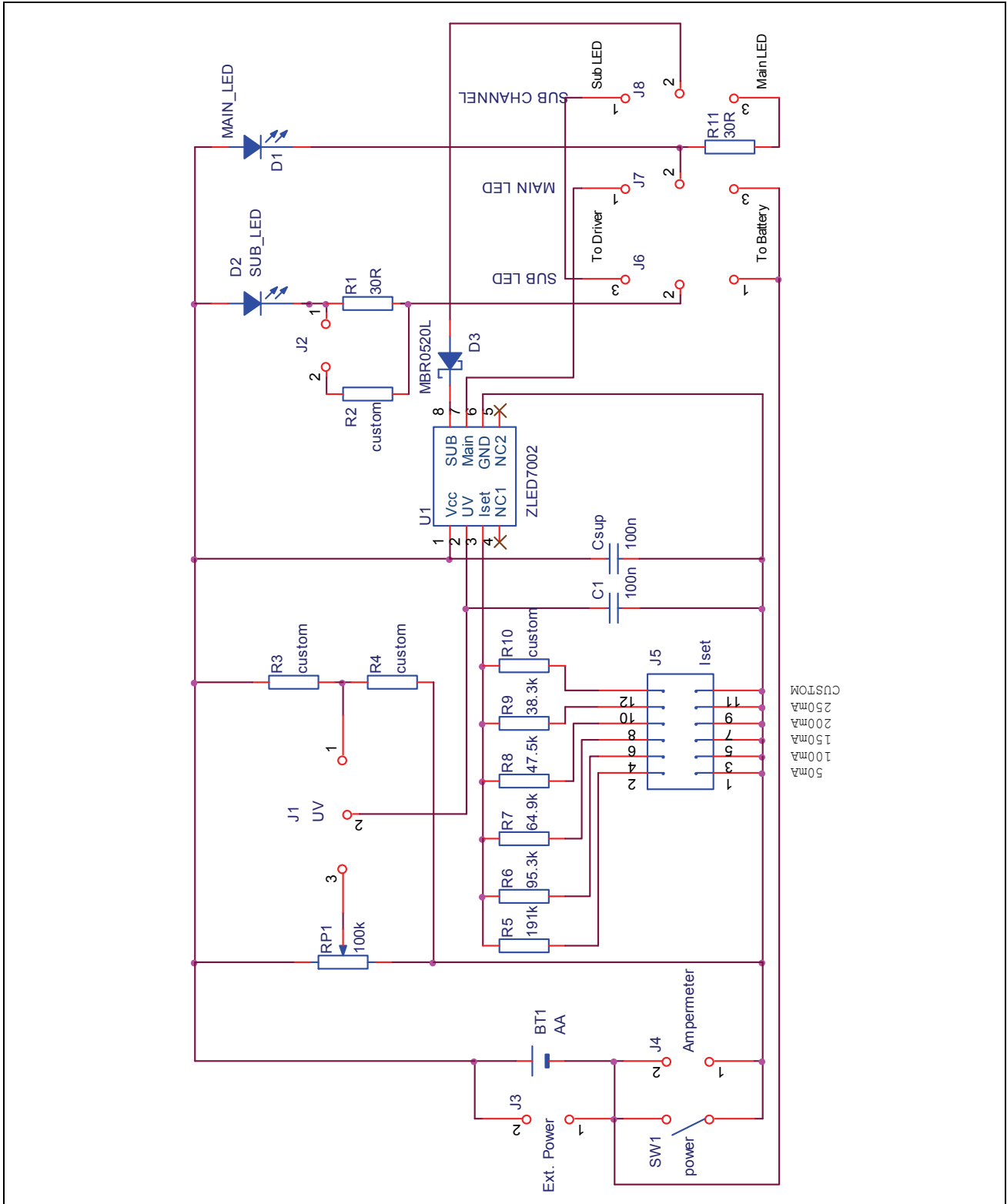

ZLED7002

ZLED7002KIT-E1 Evaluation Kit



The Analog Mixed Signal Company



3 Ordering Information

Product Sales Code	Description
ZLED7002KIT-E1	ZLED7020KIT-E1 Evaluation Kit V2.0

4 Related Documents

Document	File Name
ZLED7002 Datasheet	ZLED7002_DataSheet_Rev_X.x.pdf

Visit ZMDI's website www.zmdi.com or contact your nearest sales office for the latest version of these documents.

5 Document Revision History

Revision	Date	Description
1.0	August 04, 2011	Initial release

Sales and Further Information		www.zmdi.com	LED_drivers@zmdi.com
Zentrum Mikroelektronik Dresden AG Grenzstrasse 28 01109 Dresden Germany Phone +49 (0)351.8822.7.533 Fax +49 (0)351.8822.8.7533	ZMD America, Inc. 8413 Excelsior Drive Suite 200 Madison, WI 53717 USA Phone +1 (608) 829-1987 Fax +1 (631) 549-2882	Zentrum Mikroelektronik Dresden AG, Japan Office 2nd Floor, Shinbashi Tokyu Bldg. 4-21-3, Shinbashi, Minato-ku Tokyo, 105-0004 Japan Phone +81.3.6895.7410 Fax +81.3.6895.7301	ZMD FAR EAST, Ltd. 3F, No. 51, Sec. 2, Keelung Road 11052 Taipei Taiwan Phone +886 2 2377 8189 Fax +886 2 2377 8199
<small>DISCLAIMER: This information applies to a product under development. Its characteristics and specifications are subject to change without notice. Zentrum Mikroelektronik Dresden AG (ZMD AG) assumes no obligation regarding future manufacture unless otherwise agreed to in writing. The information furnished hereby is believed to be true and accurate. However, under no circumstances shall ZMD AG be liable to any customer, licensee, or any other third party for any special, indirect, incidental, or consequential damages of any kind or nature whatsoever arising out of or in any way related to the furnishing, performance, or use of this technical data. ZMD AG hereby expressly disclaims any liability of ZMD AG to any customer, licensee or any other third party, and any such customer, licensee and any other third party hereby waives any liability of ZMD AG for any damages in connection with or arising out of the furnishing, performance or use of this technical data, whether based on contract, warranty, tort (including negligence), strict liability, or otherwise.</small>			

Evaluation Kit August 5, 2011	© 2011 Zentrum Mikroelektronik Dresden AG — Rev. 1.1 All rights reserved. The material contained herein may not be reproduced, adapted, merged, translated, stored, or used without the prior written consent of the copyright owner. The information furnished in this publication is subject to changes without notice.	7 of 7
----------------------------------	--	--------