

Male swivel female inline adaptors c/w 1620 test point

In-line MINIMESS® male x swivel female pressure test point adaptors are a simple and easy method of adding test points into a system. Suitable for OEM build or retro-fitting to existing systems, between hose joints or manifold and hose. Special configurations are available for OEM applications.

BSP Parallel male x swivel female (60° cone sealing) test point adaptor c/w 1620 MinimesstTM test point fitted

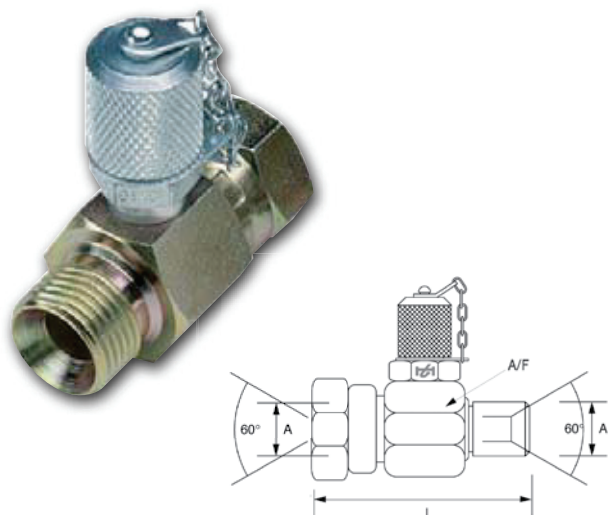

A (BSP size)	L(mm)	A/F(mm)	Part number (Carbon Steel)	Part number (Stainless Steel)
1/4"	48	25.4	SNA01	SNA01-SS
3/8"	54	25.4	SNA02	SNA02-SS
1/2"	58	27	SNA03	SNA03-SS
3/4"	64	27	SNA04	SNA04-SS
5/8"	63	30	SNA05	on request
1"	74	41	SNA06	SNA06-SS
1.1/4"	74	50	SNA07	on request
1.1/2"	82	55	SNA08	on request

Also available with 1215 & 1615 test points fitted e.g for 1215 series test point fitted to SNA01 - order as SNA01-1215.

JIC male x swivel female (37° cone sealing) test point adaptor c/w 1620 MinimesstTM test point fitted

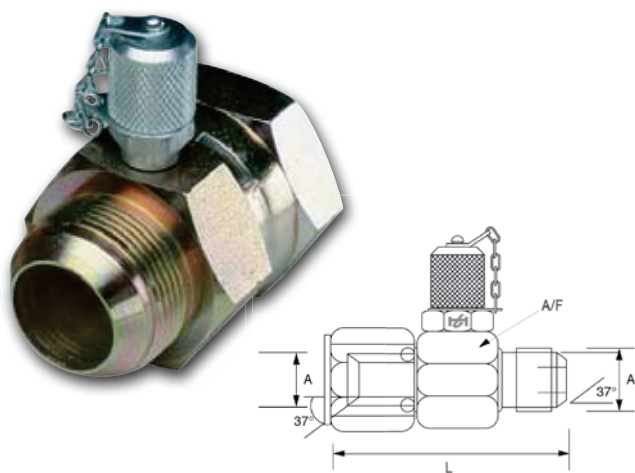

A	L(mm)	A/F(mm)	Part number
7/16"-20 UNF	53	25.4	SNA55
1/2"-20 UNF	53	25.4	SNA56
9/16"-18 UNF	55	25.4	SNA57
3/4"-16 UNF	60	32	SNA58
7/8"-14 UNF	64	25.4	SNA59
1.1/16"-12 UNF	70	32	SNA60
1.5/16"-12 UNF	74	38.1	SNA61
1.5/8"-12 UNF	78	50.8	SNA62
1.7/8"-12 UNF	85	55	SNA63

Also available with 1215 & 1615 test points fitted e.g for 1215 series test point fitted to SNA55 - order as SNA55-1215.