

Shaft Support Blocks

Shaft Support Blocks, R1057

Material

- Aluminum

Structural design

- Rigid shaft mounting due to extra-wide design
- Clamping from above for better access
- Greater security through clamping screw with larger thread diameter
- Thread for attachment from below
- Drill holes for attachment from above
- With reference edge for easy alignment

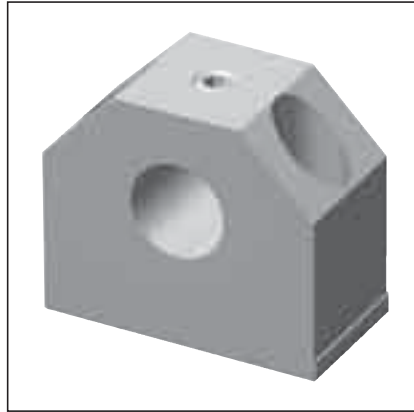

Shaft Ø d (mm)	Part numbers	Weight (kg)
10	R1057 010 00	0.05
12	R1057 012 00	0.06
16	R1057 016 00	0.11
20	R1057 020 00	0.18
25	R1057 025 00	0.35
30	R1057 030 00	0.48
40	R1057 040 00	0.90
50	R1057 050 00	1.50
60	R1057 060 00	3.00

Dimensions

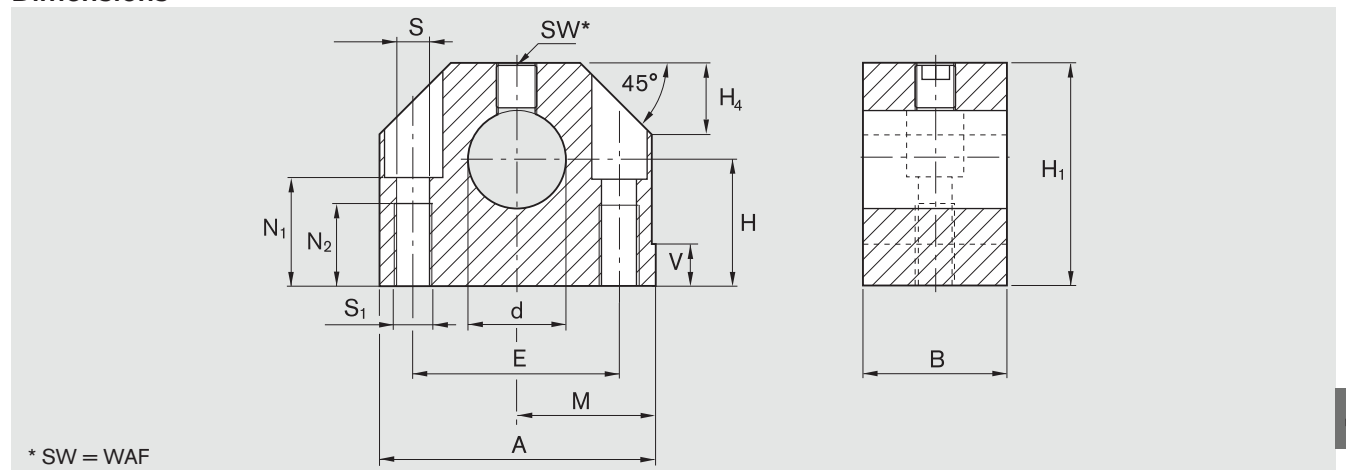

Dimensions (mm)																Tightening torque (Nm)
Ø d	d H8	H ¹⁾ ±0.01	H ₁	M ¹⁾ ±0.01	A	B	E	S ²⁾	S ₁	N ₁	N ₂	V	H ₄	WAF		
10	10	18	31	20	40	20	27±0.15	5.3	M6	14	13	5	10	2.5	3.8	
12	12	20	35	21.5	43	20	30±0.15	5.3	M6	16.5	13	5	10	2.5	3.8	
16	16	25	42	26.5	53	24	38±0.15	6.6	M8	21	18	5	13	3	6.6	
20	20	30	51	30	60	30	42±0.15	8.4	M10	25	22	5	16	4	16	
25	25	35	61	39	78	38	56±0.15	10.5	M12	30	26	6.5	20	5	30	
30	30	40	70	43.5	87	40	64±0.15	10.5	M12	34	26	8	22	5	30	
40	40	50	88	54	108	48	82±0.15	13.5	M16	44	34	10	28	6	52	
50	50	60	105	66	132	58	100±0.20	17.5	M20	49	42	12	37	8	120	
60	60	75	130	82	164	74	124±0.20	22	M27	59	42	13	42	10	220	

1) Relative to shaft nominal dimension d.

2) Mounting screws ISO 4762-8.8.