

ECL Series

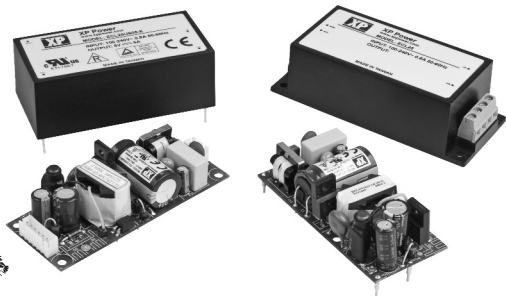

GREEN XP POWER

- Ultra Compact Size
- Single, Dual & Triple Outputs
- Open Frame PCB & Chassis Mount
- Encapsulated PCB & Chassis Mount
- <0.3 W No Load Input Power
- Peak Load Capability
- 3 Year Warranty

Specification

Input

Input Voltage	• 85-264 VAC (120-370 VDC)
Input Frequency	• 47-63 Hz
Input Current	• ECL05: 0.1 A rms, ECL10: 0.2 A rms ECL15: 0.3 A rms, ECL25: 0.4 A rms ECL30: 0.8 A rms at 230 VAC
Inrush Current	• 20 A at 115 VAC, 40 A at 230 VAC, cold start at 25 °C
Earth Leakage Current	• Class II construction no earth
Power Factor	• EN61000-3-2, class A
No Load Input Power	• <0.3 W
Input Protection	• ECL05/10: Internal T1 A/250 VAC fuse ECL15/25/30: Internal T2 A/250 VAC fuse

Output

Output Voltage	• See tables
Output Voltage Trim	• $\pm 5\%$ on output 1 only, on multiple output versions, V2 & V3 will track by same percentage, (not '-E' or '-S' versions)
Initial Set Accuracy	• $\pm 1\%$ for output 1, $\pm 1\%$ for output 2 of UD01 & UD02 versions, $\pm 5\%$ for output 2 & output 3 of other versions
Minimum Load	• Single output versions: none, Multi output versions: UD01 & UD02: 10% V1 & V2 UD03: 10% V1, 20% V2 UT02 & UT03: 10% V1, 20% V2 & V3 to meet regulation specifications
Start Up Delay	• 3 s max
Start Up Rise Time	• 14 ms max
Hold Up Time	• 16 ms typical for single output versions, 12 ms typical for multiple output versions, at full load & 115 VAC
Line Regulation	• $\pm 0.5\%$ max for single output versions and output 1 of multiple output versions, $\pm 0.9\%$ max for output 2 & output 3 of multiple output versions
Load Regulation	• 1% max for single output versions, for multiple output versions (see note 5)
Cross Regulation	• Multi output versions only (see note 5)
Transient Response	• 4% max deviation, recovery to within 1% in 500 μ s for a 25% load change
Ripple & Noise	• Single output versions: 3.3-5 V versions: 50 mV pk-pk, 12-15 V versions: 120 mV pk-pk, 24-48 V versions: 200 mV pk-pk, Multiple output versions: 1% pk-pk on any output, 20 MHz bandwidth
Overvoltage Protection	• 115-140% Vnom
Overload Protection	• Single output versions: ECL05/10/15: 120-150%, ECL25: 120-170% of total power Multiple output versions: 140-200% of total power
Short Circuit Protection	• Trip and restart (hiccup mode)
Temperature Coefficient	• 0.05%/°C

General

Efficiency	• See tables
Isolation	• 3000 VAC Input to Output
Switching Frequency	• 70 kHz typical
Power Density	• ECL05: 2.25 W/In ³ (PCB Mount version) ECL10: 5.50 W/In ³ (PCB Mount version) ECL15: 5.30 W/In ³ (PCB Mount version) ECL25: 5.90 W/In ³ (PCB Mount version) ECL30: 7.10 W/In ³ (PCB Mount version)
MTBF	• ECL05/10: >450 kHrs, ECL15/25/30: >400 kHrs, to MIL-HDBK-217F at 25 °C, GB

Environmental

Operating Temperature	• -20 °C to +70 °C, derate linearly from 100% at +50 °C to 50% at +70 °C
Cooling	• Convection-cooled
Operating Humidity	• 95% RH, non-condensing
Storage Temperature	• -40 °C to +85 °C
Operating Altitude	• 3000 m
Vibration	• 2 g, 10 Hz to 500 Hz, 10 mins/cycle, 60 mins each cycle

EMC & Safety

Emissions	• EN55022, level B conducted & radiated
Harmonic Currents	• EN61000-3-2, class A
Voltage Flicker	• EN61000-3-3
ESD Immunity	• EN61000-4-2, level 3 Perf Criteria A
Radiated Immunity	• EN61000-4-3, 10 V/m 80% mod Perf Criteria A
EFT/Burst	• EN61000-4-4, level 3, Perf Criteria A
Surge	• EN61000-4-5, installation class 3, Perf Criteria A
Conducted Immunity	• EN61000-4-6, 10 Vrms Perf Criteria A
Magnetic Fields	• EN61000-4-8, 10 A/m, Perf Criteria A
Dips & Interruptions	• EN61000-4-11, 30% for 10 ms, 60% for 100 ms, 100% for 5000 ms Perf Criteria A, B, B
Safety Approvals	• IEC60950-1, EN60950-1, UL60950-1, CSA22.2 No. 234 per cUL

Models and Ratings

Output Power	Output Voltage	Output Current		Efficiency	Model Number ⁽²⁾
		Nominal	Peak ⁽¹⁾		
4.3 W	3.3 VDC	1.30 A	1.69 A	72%	ECL05US03†^
5.0 W	5.0 VDC	1.00 A	1.30 A	75%	ECL05US05†^
5.0 W	9.0 VDC	0.55 A	0.71 A	78%	ECL05US09†^
5.0 W	12.0 VDC	0.41 A	0.54 A	78%	ECL05US12†^
5.0 W	15.0 VDC	0.33 A	0.44 A	80%	ECL05US15†^
5.0 W	24.0 VDC	0.21 A	0.27 A	82%	ECL05US24†^
5.0 W	48.0 VDC	0.10 A	0.13 A	82%	ECL05US48†^
8.6 W	3.3 VDC	2.60 A	3.38 A	72%	ECL10US03†^
10.0 W	5.0 VDC	2.00 A	2.60 A	75%	ECL10US05†^
10.0 W	9.0 VDC	1.10 A	1.43 A	78%	ECL10US09†^
10.0 W	12.0 VDC	0.83 A	1.08 A	78%	ECL10US12†^
10.0 W	15.0 VDC	0.67 A	0.87 A	80%	ECL10US15†^
10.0 W	24.0 VDC	0.42 A	0.55 A	82%	ECL10US24†^
10.0 W	48.0 VDC	0.21 A	0.27 A	82%	ECL10US48†^

Notes

1. Peak load lasting <30 s with a maximum duty cycle of 10%, average output power not to exceed nominal.
2. Add suffix to model number to define type: add '-P' for PCB mount, add '-T' for chassis mount, add '-E' for encapsulated.

† Available from Farnell & element14.

^ Available from Newark.

Mechanical Details

Open Frame - PCB Mount (-P)

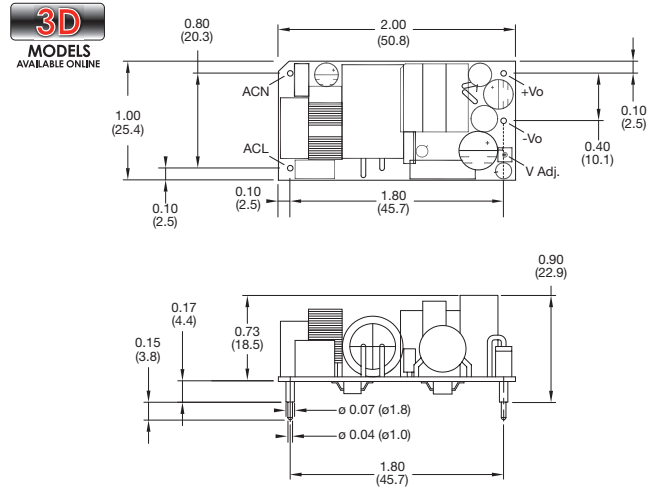

Open Frame - Chassis Mount (-T)

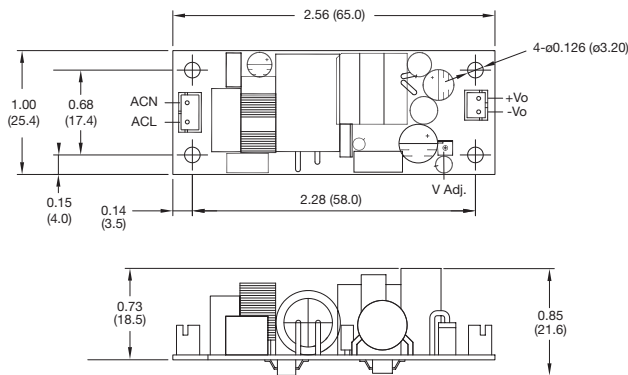

Notes

1. All dimensions in inches (mm).
2. Weight: ECL05/10 P Version: 0.057 lbs (26 g)
ECL05/10 T Version: 0.057 lbs (26 g)
ECL05/10 E Version: 0.13 lbs (60 g)
3. Tolerances: x.xx = ± 0.02 (x.x = ± 0.5)
x.xxx = ± 0.01 (x.xx = ± 0.25)

Encapsulated (-E)

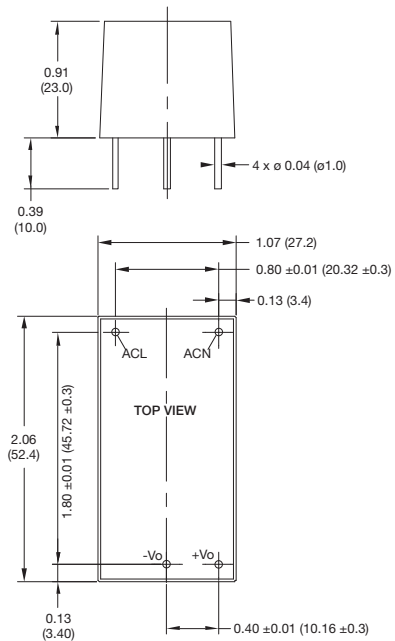

Mating Connectors (-T version only)

Input Connector: JST PHR-3
Output Connector: JST PHR-2
Crimps: SPH-002T-P0.5S
Cable harness with 300 mm wire available, order part no. ECL10 LOOM KIT



Models and Ratings

Output Power	Output Voltage	Output Current		Efficiency	Model Number ^(2,3)
		Nominal	Peak ⁽¹⁾		
10 W	3.3 VDC	3.00 A	3.90 A	75%	ECL15US03†^
15 W	5.0 VDC	3.00 A	3.90 A	78%	ECL15US05†^
15 W	9.0 VDC	1.67 A	2.17 A	80%	ECL15US09†^
15 W	12.0 VDC	1.25 A	1.62 A	80%	ECL15US12†^
15 W	15.0 VDC	1.00 A	1.30 A	80%	ECL15US15†^
15 W	24.0 VDC	0.63 A	0.82 A	82%	ECL15US24†^
15 W	48.0 VDC	0.32 A	0.41 A	82%	ECL15US48†^

Notes

1. Peak load lasting <30 s with a maximum duty cycle of 10%, average output power not to exceed nominal.
2. Add suffix to model number to define type: add '-P' for PCB mount, add '-T' for chassis mount, add '-E' for encapsulated, add '-S' for screw terminals.
3. A screw terminal version (-S) is available with DIN clip attached, add suffix 'D', e.g. ECL15US24-SD, DIN rail mounting kit is available as a separate item, order code ECL15 DIN CLIP.
4. For medically-approved 15 W power supplies contact sales or see www.xppower.com for details of CU15-M series and VCP15 series.

† Available from Farnell & element14.

^ Available from Newark.

Mechanical Details

Open Frame - PCB Mount (-P)

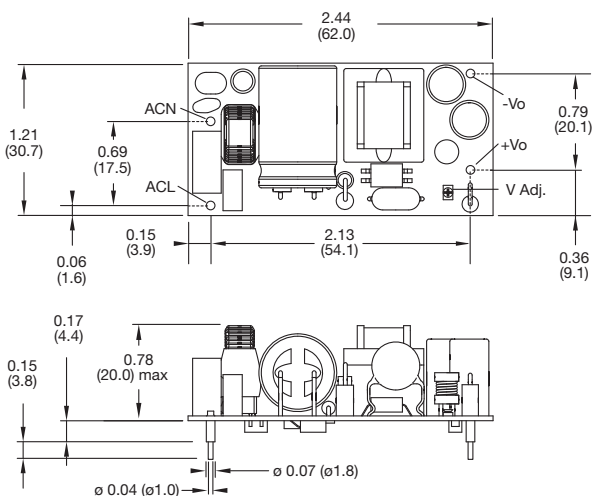

Encapsulated (-E)

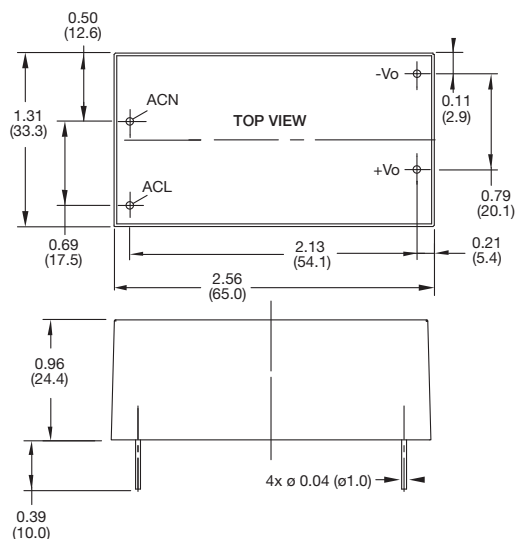

Open Frame - Chassis Mount (-T)

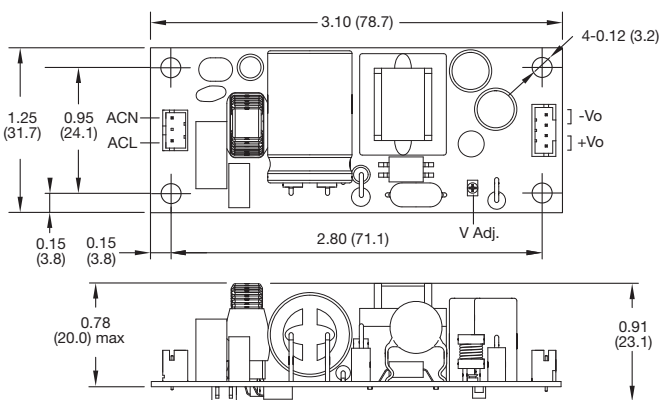

Screw Terminal (-S)

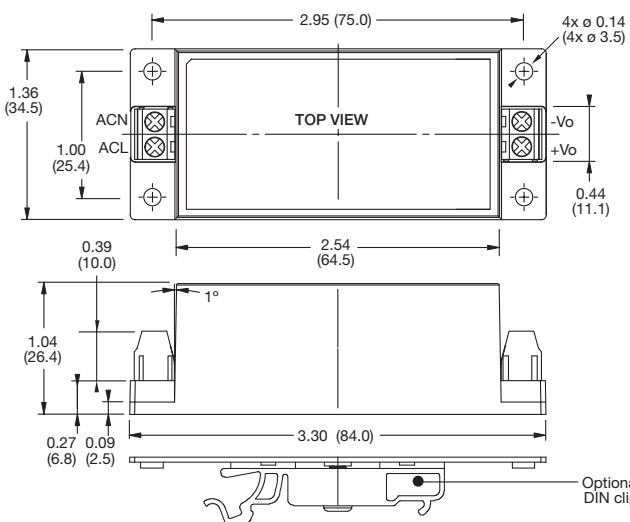

Notes

1. All dimensions in inches (mm).
2. Weight: ECL15 P Version: 0.07 lbs (35 g)
T Version: 0.07 lbs (35 g)
E Version: 0.20 lbs (90 g)
S Version: 0.24 lbs (110 g)
3. Tolerances: x.xx = ± 0.02 (x.x = ± 0.5)
x.xxx = ± 0.01 (x.xx = ± 0.25)

Mating Connectors (-T version only)

- Input Connector: JST PHR-3
- Output Connector: JST PHR-4
- Crimps: SPH-002T-P0.5S
- Cable harness with 300 mm wire available, order part no. ECL15 LOOM KIT

Models and Ratings

Output Power	Output 1		Output 2		Output 3		Efficiency	Model Number ^(3,4)
	Voltage	Current ⁽²⁾	Voltage	Current ⁽²⁾	Voltage	Current ⁽²⁾		
15 W	+12.0 V	0.65 A	-12.0 V	0.650 A			82%	ECL15UD01 [†] ▲
15 W	+15.0 V	0.50 A	-15.0 V	0.500 A			82%	ECL15UD02 [†] ▲
15 W	5.0 V ⁽¹⁾	1.50 A	12.0 V ⁽¹⁾	0.625 A			81%	ECL15UD03 [†]
15 W	5.0 V ⁽¹⁾	2.00 A	+12.0 V	0.200 A	-12.0 V	0.200 A	81%	ECL15UT02 [†] ▲
15 W	5.0 V ⁽¹⁾	2.00 A	+15.0 V	0.150 A	-15.0 V	0.150 A	81%	ECL15UT03 [†] ▲

Notes

1. Isolated output
2. Peak load of 130% lasting <30 s with a maximum duty cycle of 10%, average output power not to exceed nominal.
3. Add suffix to model number to define type: add '-P' for PCB mount, add '-T' for chassis mount, add '-E' for encapsulated, add '-S' for screw terminals.
4. A screw terminal version (-S) is available with DIN clip attached, add suffix 'D' e.g. ECL15UT02-SD, DIN rail mounting kit is available as a separate item, order code ECL15 DIN CLIP.
5. UD01/UD02: Load regulation <3%, 10-100% load.
Cross regulation <3%, one output fixed, the other varied from 10-100% load
UD03: Load regulation <1% V1, <10% V2
Cross regulation <10% V2, V1 varied from 10-100% load
UT02/UT03: Load regulation <1% V1, <10% V2 & V3
Cross regulation <10% V2 & V3, V2 & V3 at 50% load & V1 varied from 20-100% load

Mechanical Details

Open Frame - PCB Mount (-P)

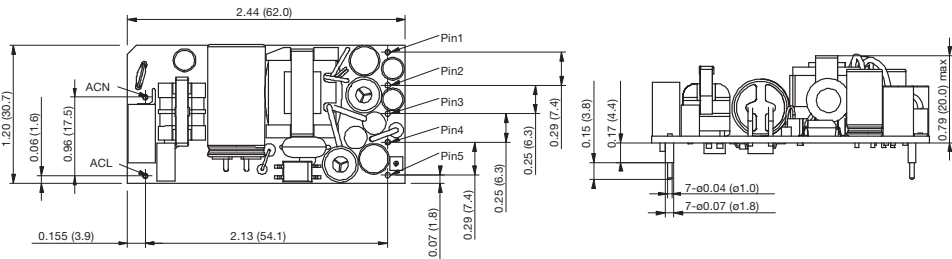

Pin	UD01/02	UD03	UT02/03
1	V2	NP	V3
2	NP	V2 RTN	COM
3	COM	V2	V2
4	V1	V1	V1
5	NP	V1 RTN	V1 RTN

NP = No pin.

Open Frame - Chassis Mount (-T)

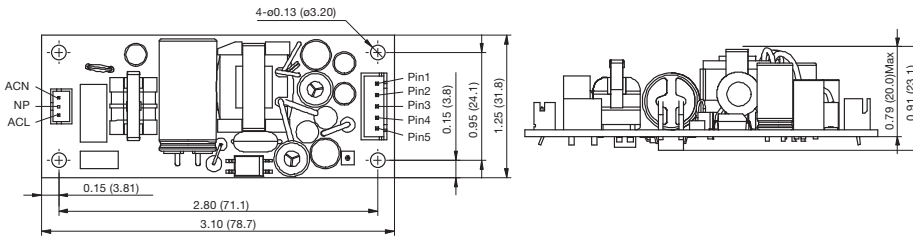

Pin	UD01/02	UD03	UT02/03
1	V2	NC	V3
2	COM	V2 RTN	COM
3	COM	V2	V2
4	COM	V1	V1
5	V1	V1 RTN	V1 RTN

NC = No connection.

Encapsulated (-E)

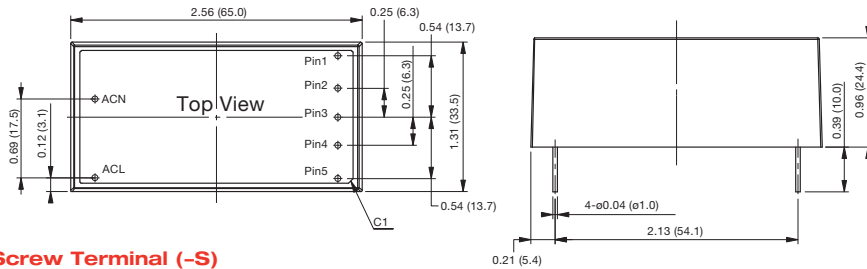

Pin	UD01/02	UD03	UT02/03
1	V2	NP	V3
2	NP	V2 RTN	COM
3	COM	V2	V2
4	V1	V1	V1
5	NP	V1 RTN	V1 RTN

NP = No pin.

Screw Terminal (-S)

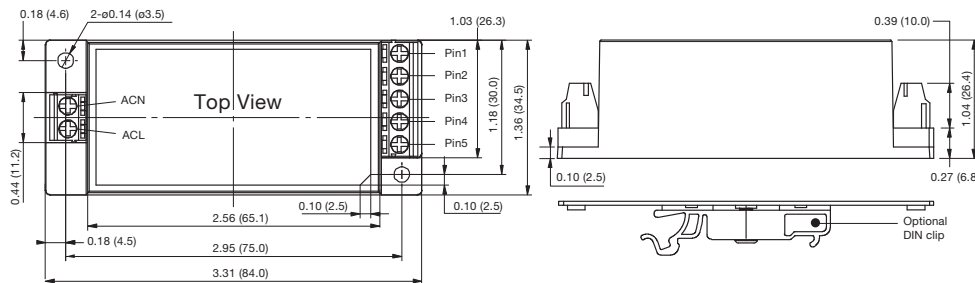

Pin	UD01/02	UD03	UT02/03
1	V2	NC	V3
2	COM	V2 RTN	COM
3	COM	V2	V2
4	COM	+V1	V1
5	V1	V1 RTN	V1 RTN

NC = No connection.

Notes

1. All dimensions in inches (mm).
2. Tolerances: x.xx = ± 0.02 (x.x = ± 0.5)
x.xxx = ± 0.01 (x.xx = ± 0.25)
3. Weight: ECL15 UD/UT: P Version: 0.09 lbs (40 g)
T Version: 0.09 lbs (40 g)
E Version: 0.21 lbs(95 g)
S Version: 0.26 lbs (120 g)

Mating Connectors (-T version only)

Input Connector: JST PHR-3
Output Connector: JST XHP-5

Models and Ratings

Output Power	Output Voltage	Output Current		Efficiency	Model Number ^(2,3)
		Nominal	Peak ⁽¹⁾		
20 W	3.3 VDC	6.00 A	7.80 A	75%	ECL25US03†^
25 W	5.0 VDC	5.00 A	6.50 A	78%	ECL25US05†^
25 W	9.0 VDC	2.80 A	3.64 A	80%	ECL25US09†^
25 W	12.0 VDC	2.10 A	2.73 A	80%	ECL25US12†^
25 W	15.0 VDC	1.67 A	2.17 A	80%	ECL25US15†^
25 W	24.0 VDC	1.04 A	1.35 A	82%	ECL25US24†^
25 W	48.0 VDC	0.52 A	0.68 A	82%	ECL25US48†^

Notes

1. Peak load lasting <30 s with a maximum duty cycle of 10%, average output power not to exceed nominal.
2. Add suffix to model number to define type: add '-P' for PCB mount, add '-T' for chassis mount, add '-E' for encapsulated, add '-S' for screw terminals.

† Available from Farnell & element14.

3. A screw terminal version (-S) is available with DIN clip attached, add suffix 'D', e.g. ECL25US24-SD, DIN rail mounting kit is available as a separate item, order code ECL25/30 DIN CLIP.

^ Available from Newark.

Mechanical Details

Open Frame - PCB Mount (-P)

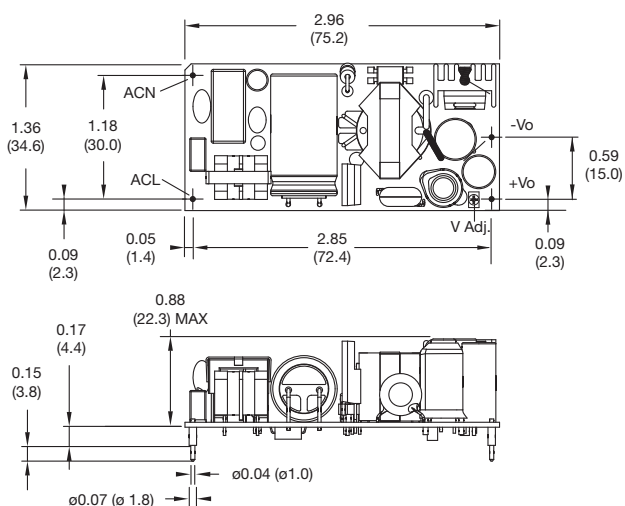

Encapsulated (-E)

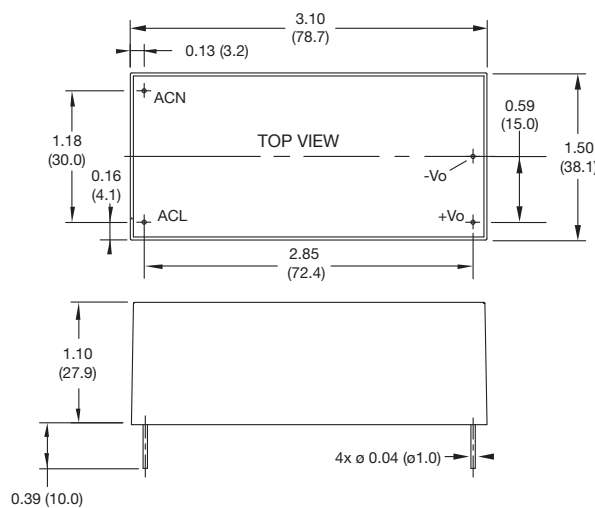

Open Frame - Chassis Mount (-T)

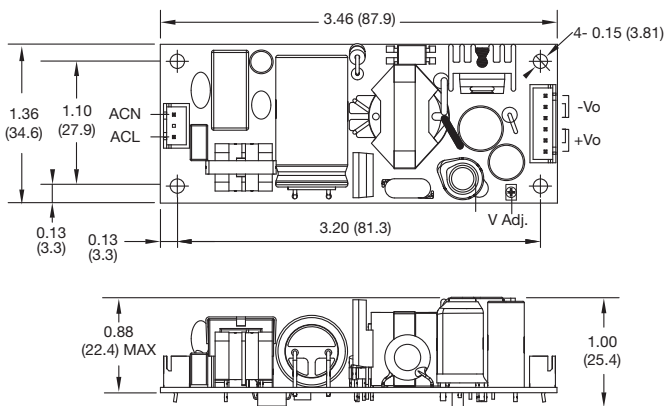

Screw Terminal (-S)

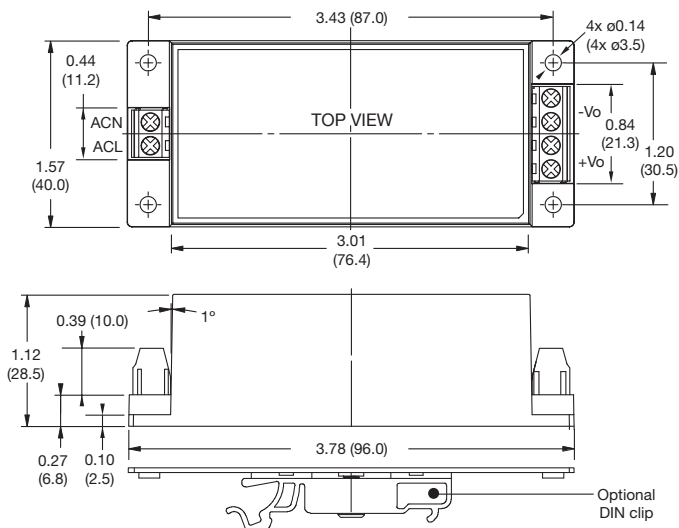

Notes

1. All dimensions in inches (mm).
2. Weight: ECL25: P Version: 0.14 lbs (66 g)
T Version: 0.14 lbs (66 g)
E Version: 0.33 lbs (150 g)
S Version: 0.37 lbs (170 g)
3. Tolerances: x.xx = ± 0.02 (x.x = ± 0.5)
x.xxx = ± 0.01 (x.xx = ± 0.25)

Mating Connectors (-T version only)

- Input Connector: JST XHP-3
- Output Connector: JST XHP-6
- Crimps: SXH-002T-P0.6
- Cable harness with 300 mm wire available, order part no. ECL25 LOOM KIT

Models and Ratings

Output Power	Output 1		Output 2		Output 3		Efficiency	Model Number ^(3,4)
	Voltage	Current ⁽²⁾	Voltage	Current ⁽²⁾	Voltage	Current ⁽²⁾		
30 W	+12.0 V	1.3 A	-12.0 V	1.30 A			84%	ECL30UD01†^
30 W	+15.0 V	1.0 A	-15.0 V	1.00 A			83%	ECL30UD02†^
30 W	5.0 V ⁽¹⁾	3.0 A	12.0 V ⁽¹⁾	1.30 A			81%	ECL30UD03†^
30 W	5.0 V ⁽¹⁾	3.0 A	+12.0 V	0.63 A	-12.0 V	0.63 A	83%	ECL30UT02†^
30 W	5.0 V ⁽¹⁾	3.0 A	+15.0 V	0.50 A	-15.0 V	0.50 A	81%	ECL30UT03†^

Notes

1. Isolated output
2. Peak load of 130% lasting <30 s with a maximum duty cycle of 10%, average output power not to exceed nominal.
3. Add suffix to model number to define type: add '-P' for PCB mount, add '-T' for chassis mount, add '-E' for encapsulated, add '-S' for screw terminals.
4. A screw terminal version (-S) is available with DIN clip attached, add suffix 'D' e.g. ECL30UT02-SD, DIN rail mounting kit is available as a separate item, order code ECL25/30 DIN CLIP.
5. UD01/UD02: Load regulation <3%, 10-100% load.
Cross regulation <3%, one output fixed, the other varied from 10-100% load
UD03: Load regulation <1% V1, <10% V2
Cross regulation <10% V2, V1 varied from 10-100% load
UT02/UT03: Load regulation <1% V1, <10% V2 & V3
Cross regulation <10% V2 & V3, V2 & V3 at 50% load & V1 varied from 20-100% load

Mechanical Details

Open Frame - PCB Mount (-P)

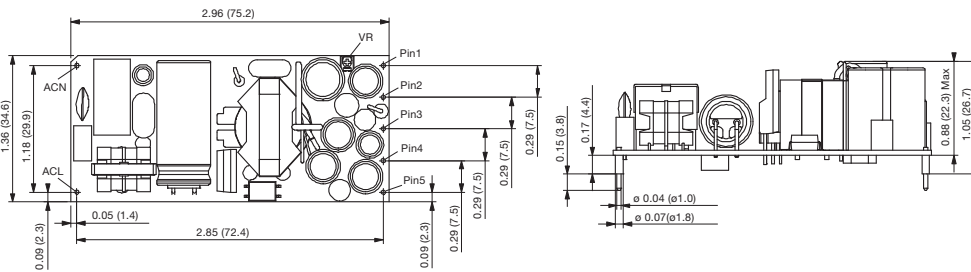

Pin	UD01/02	UD03	UT02/03
1	NP	V1 RTN	V1 RTN
2	NP	V1	V1
3	V2	NP	V3
4	COM	V2 RTN	COM
5	V1	V2	V2

NP = No pin.

Open Frame - Chassis Mount (-T)

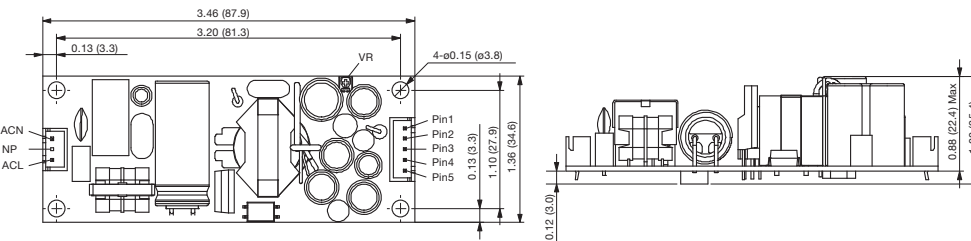

Pin	UD01/02	UD03	UT02/03
1	V2	V1 RTN	V1 RTN
2	COM	V1	V1
3	COM	NC	V3
4	COM	V2 RTN	COM
5	V1	V2	V2

NC = No connection.

Encapsulated (-E)

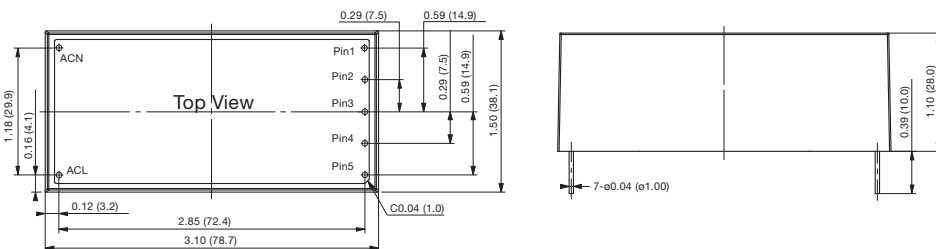

Pin	UD01/02	UD03	UT02/03
1	NP	V1 RTN	V1 RTN
2	NP	V1	V1
3	V2	NP	V3
4	COM	V2 RTN	COM
5	V1	V2	V2

NP = No pin.

Screw Terminal (-S)

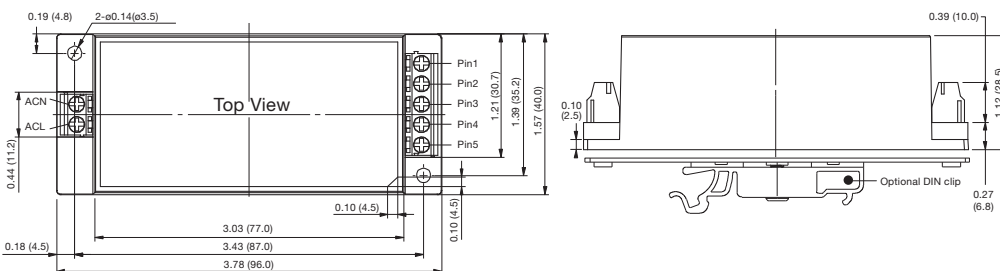

Pin	UD01/02	UD03	UT02/03
1	V2	V1 RTN	V3
2	COM	V1	COM
3	COM	NC	V2
4	COM	V2 RTN	V1
5	V1	V2	V1 RTN

NC = No connection.

Notes

1. All dimensions in inches (mm).
2. Tolerances: x.xx = ± 0.02 (x.x = ± 0.5)
x.xxx = ± 0.01 (x.xx = ± 0.25)
3. Weight: ECL30 UD/UT: P Version: 0.13 lbs (60 g)
T Version: 0.13 lbs (60 g)
E Version: 0.34 lbs (155 g)
S Version: 0.39 lbs (175 g)

Mating Connectors (-T version only)

Input Connector: JST XHP-3
Output Connector: JST XHP-8