

A-max 16 $\varnothing 16$ mm, Precious Metal Brushes CLL, 2 Watt, CE approved

Kabel AWG 26/7
 cable UL Style 1061
 (+) Kabel rot
 cable red

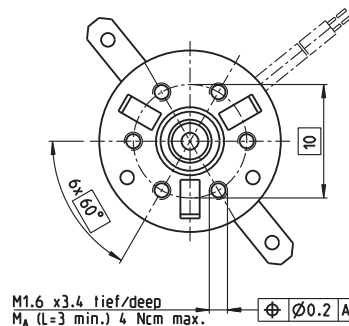
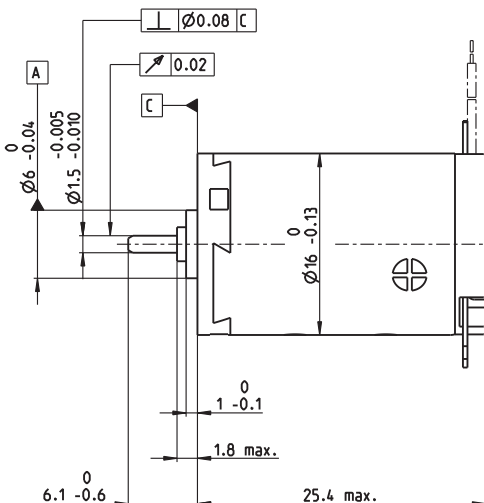
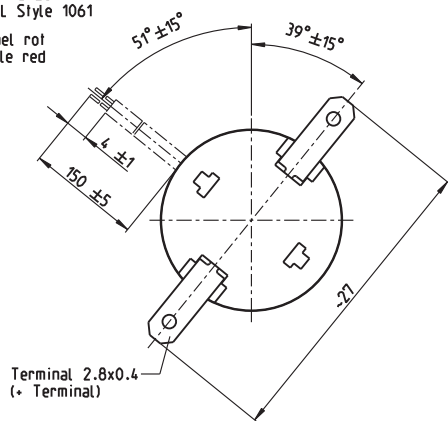

M 1.5:1

- Stock program
- Standard program
- Special program (on request)

Article Numbers

with terminals	110041	110042	110043	110044	110045	110046	110047	110048	110049	110050
with cables	139820	352815	134844	231379	220514	304672	352823	352816	260678	352817

Motor Data

Values at nominal voltage																					
1 Nominal voltage	V	1.5	3	6	9	12	15	18	21	24	30										
2 No load speed	rpm	10800	12300	10100	12300	12300	13200	14100	13700	13800	11400										
3 No load current	mA	61.4	38.1	13.9	12.7	9.54	8.57	7.99	6.53	5.83	3.37										
4 Nominal speed	rpm	9360	8810	4530	6700	6660	7590	8480	8040	8120	5480										
5 Nominal torque (max. continuous torque)	mNm	0.712	1.3	2.22	2.19	2.17	2.17	2.15	2.14	2.11	2.08										
6 Nominal current (max. continuous current)	A	0.6	0.6	0.408	0.327	0.243	0.209	0.185	0.153	0.134	0.0864										
7 Stall torque	mNm	4.79	4.51	4.03	4.82	4.77	5.16	5.44	5.22	5.12	4.04										
8 Starting current	A	3.66	1.97	0.723	0.702	0.52	0.482	0.453	0.362	0.315	0.164										
9 Max. efficiency	%	77	75	75	76	76	76	76	76	76	74										
Characteristics																					
10 Terminal resistance	Ω	0.41	1.52	8.3	12.8	23.1	31.1	39.7	57.9	76.2	183										
11 Terminal inductance	mH	0.017	0.0519	0.306	0.467	0.831	1.13	1.42	2.05	2.61	6.01										
12 Torque constant	mNm/A	1.31	2.29	5.57	6.88	9.17	10.7	12	14.4	16.3	24.7										
13 Speed constant	rpm/V	7290	4170	1720	1390	1040	893	795	663	587	387										
14 Speed / torque gradient	rpm/mNm	2280	2770	2560	2590	2620	2600	2630	2670	2750	2880										
15 Mechanical time constant	ms	25.3	23.8	23.3	23.3	23.3	23.4	23.5	23.4	23.5	23.9										
16 Rotor inertia	gcm ²	1.06	0.82	0.868	0.859	0.849	0.859	0.852	0.838	0.816	0.793										

Specifications

- Thermal data**
- 17 Thermal resistance housing-ambient: 29.8 K/W
 - 18 Thermal resistance winding-housing: 5.5 K/W
 - 19 Thermal time constant winding: 3.55 s
 - 20 Thermal time constant motor: 165 s
 - 21 Ambient temperature: -30...+65°C
 - 22 Max. permissible winding temperature: +85°C
- Mechanical data (sleeve bearings)**
- 23 Max. permissible speed: 19000 rpm
 - 24 Axial play: 0.05 - 0.15 mm
 - 25 Radial play: 0.012 mm
 - 26 Max. axial load (dynamic): 0.8 N
 - 27 Max. force for press fits (static): 35 N
 - 28 Max. radial loading, 5 mm from flange: 1.4 N

- Mechanical data (ball bearings)**
- 23 Max. permissible speed: 19000 rpm
 - 24 Axial play: 0.05 - 0.15 mm
 - 25 Radial play: 0.025 mm
 - 26 Max. axial load (dynamic): 2.2 N
 - 27 Max. force for press fits (static): 30 N
 - 28 Max. radial loading, 5 mm from flange: 7.8 N

- Other specifications**
- 29 Number of pole pairs: 1
 - 30 Number of commutator segments: 7
 - 31 Weight of motor: 21 g
- CLL = Capacitor Long Life

Values listed in the table are nominal.
 Explanation of the figures on page 49.

Option
 Ball bearings in place of sleeve bearings
 Without CLL

Operating Range

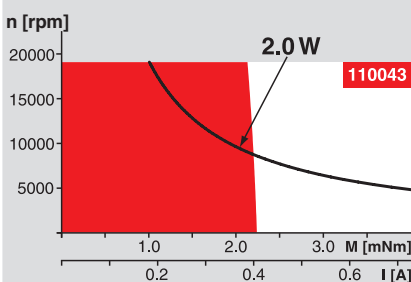

Comments

- Continuous operation**
 In observation of above listed thermal resistance (lines 17 and 18) the maximum permissible winding temperature will be reached during continuous operation at 25°C ambient.
 = Thermal limit.
- Short term operation**
 The motor may be briefly overloaded (recurring).
- Assigned power rating**

maxon Modular System

Overview on page 16 - 21

Spur Gearhead

$\varnothing 16$ mm

0.01 - 0.1 Nm

Page 212 - 215

Planetary Gearhead

$\varnothing 16$ mm

0.06 - 0.18 Nm

Page 216

Planetary Gearhead

$\varnothing 16$ mm

0.1 - 0.6 Nm

Page 217/218

Spindle Drive

$\varnothing 16$ mm

Page 251/252

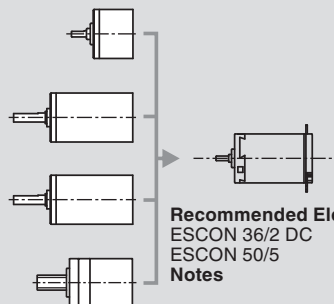

Recommended Electronics:
 ESCON 36/2 DC Page 292
 ESCON 50/5 Page 292

Notes 18