

Power Relay PK2 Latching (THT – THR)

- Reduced coil power consumption of latching version allows higher limiting continuous current (50A) and increased ambient temperature (125°C)
- Maximum switch on current 200A
- 60% volume reduced Power K at increased performance
- PCB area requirements minimized by 50% to only 293mm²
- Size optimized to L x W x H 18.3x16x15.9mm
- Design allows highest reliability
- High shock and vibration resistance
- No change of switching state version at breakdown of battery voltage
- For monostable version refer to Power Relay PK2 (THT – THR)

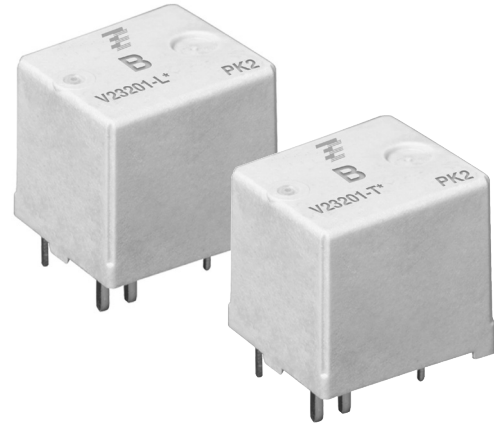

201L-T_fw1b

Typical applications

Energy management, engine control, ignition, main switch/supply relay, preheating system, quiescent current management.

Contact Data

Contact arrangement	1 form A, 1 NO
Rated voltage	12VDC
Rated current	50A ¹⁾
Limiting continuous current	
23°C	50A ¹⁾
85°C	40A ¹⁾
125°C	30A ¹⁾
Limiting making current, pin 4-5, THT/THR	200A ²⁾³⁾
Limiting breaking current, pin 4-5, THT/THR	40A ²⁾
Contact material	AgSnO ₂
Min. recommended contact load	1A at 5VDC ⁴⁾
Initial voltage drop at 10A, typ./max.	30/300mV
Frequency of operation at nominal load	6 ops./min (0.1Hz)
Operate/release time	typ. 1.5ms
Electrical endurance	
at cyclic temperature -40/+23/+85°C, 13.5VDC, 120ms (on), 4.88s (off),	
motor load: L=0.5mH, 60A (on)/35A (off)	>1x10 ⁵ ops. ⁵⁾
resistive load: 40A (on)/40A (off)	>1x10 ⁵ ops. ⁵⁾
capacitive load 200A (on)/20A (off)	>1x10 ⁵ ops. ⁵⁾
Mechanical endurance	>2x10 ⁶ ops.

- 1) Measured on 70x70x1.5mm epoxy PCB FR4 with 52cm² (double layer 140µm) copper area. The load circuit shall withstand current applied until 40A ATO fuse blows.
- 2) The values apply to a resistive or inductive load with suitable spark suppression and at maximum 13.5VDC for 12VDC load voltages.
- 3) Corresponds to a capacitive peak inrush current on initial actuation (cold filament).
- 4) See chapter Diagnostics of Relays in our Application Notes or consult the internet at <http://relays.te.com/appnotes/>
- 5) Be aware of using right polarity, see Terminal Assignment. Wrong polarity will reduce endurance.

Max. DC load breaking capacity

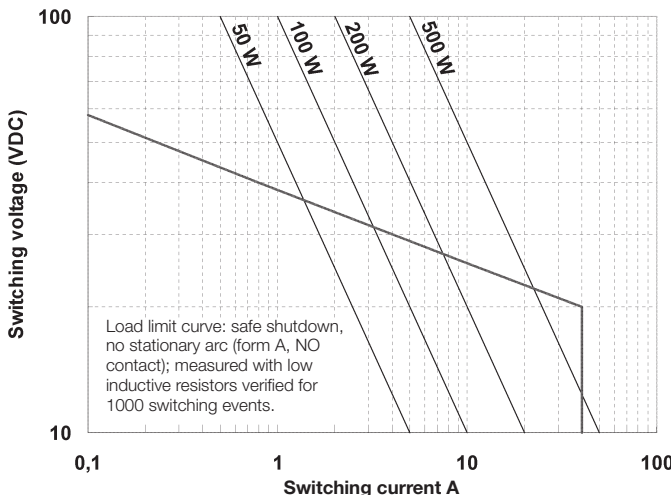

Coil Data

Magnetic system	bistable (two coil system)			
Coil voltage range	23°C (set - reset) 28/18VDC ⁶⁾			
Rated coil voltage	12VDC			
Polarity for set/reset energization	set	reset		
	-	+	-	+
	pin 1	pin 6	pin 2	pin 6

Coil versions, bistable 2 coils

Coil code	Rated voltage VDC	Set voltage VDC	Reset voltage VDC	Set/reset coil resistance Ω±10%	Impulse lenght ms
004/006	12	6.9	6.9	20/19	10 – 100

All figures are given for coil without preenergization, at ambient temperature +23°C.
6) Overvoltage according to ISO 16750-2 functional status C. In case of a reset latch pulse U>18VDC contact may reclose, but will not remain closed (no latching function). The delay between driving impulses at cyclic energizing at Tamb=85°C must be at least 10s.

Insulation Data

Initial dielectric strength between contact and coil	500VAC _{rms}
--	-----------------------

Other Data

EU RoHS/ELV compliance	compliant, THT: sealed type washable THR: sealed type vented
Ambient temperature	-40 to +125°C
Cold storage, IEC 60068-2-1	1000h; -40°C
Dry heat, IEC 60068-2-2	1000h; +125°C
Temperature cycling (shock), IEC 60068-2-14, Na	1000 cycles, -40/+125°C, dwell time 15min
Degree of protection	
THT:	RT III (IEC 61810), IP67 (IEC 60529)
THR:	RT II (IEC 61810), IP56 (IEC 60529)
Sealing test, IEC 60068-2-17	
THT:	Qc, method 2, 1min, 70°C
Vibration resistance (functional), IEC 68-2-6 (sine pulse form), 30 to 440Hz, no change in the switching stte >10µs	>20g
Shock resistance (functional), IEC 68-2-27 (half sine form single pulses)	
open NO contact will not close >10µs	6ms >30g
closed NO contact will not open >10µs	11ms >100g

Power Relay PK2 Latching (THT – THR) (Continued)

Other Data (continued)

Terminal type	PCB THT, THR	
Weight	approx. 11g (0.39oz)	
Solderability (aging 3: 4h/155°C) ⁷⁾		
THT, IEC 60068-2-20	Ta, method 1, hot dip 5s, 215°C	
THR, IEC 60068-2-58	hot dip 5s, 245°C	
Resistance to soldering heat THT		
IEC 60068-2-20	Tb, method 1A hot dip 10s, 260°C, with thermal screen	
Resistance to soldering heat THR		
IEC 60068-2-58	hot dip 10s 260°C, preheating min. 130°C	
Storage conditions	according IEC 600688 ⁸⁾	
Packaging unit and delivery ⁹⁾	600 pcs.	

- 7) For leaded process (Tm = 183°C), for Pb-free process (Tm = 217°C).
- 8) For general storage and processing recommendations please refer to our Application Notes and especially to Storage in the Definitions or at <http://relays.te.com/appnotes/>
- 9) Bistable relays are delivered in the reset position. Due to mechanical impacts while transportation, we advise to check the contact status after the incoming. Before entering the product into the reflow soldering process, please make sure that the relay is unlatched, in order to maintain its performance. Latching (Delivery status "ex works").

Terminal Assignment

Bottom view on solder pins

1 form A, NO

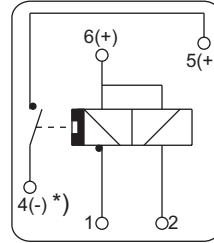

201L_PA2

*) Polarity as stated is compulsory

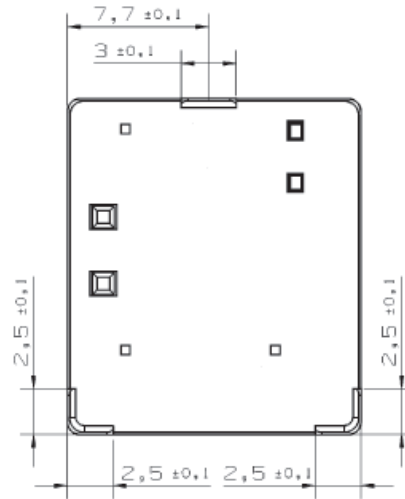

201LT_PIN

Dimensions

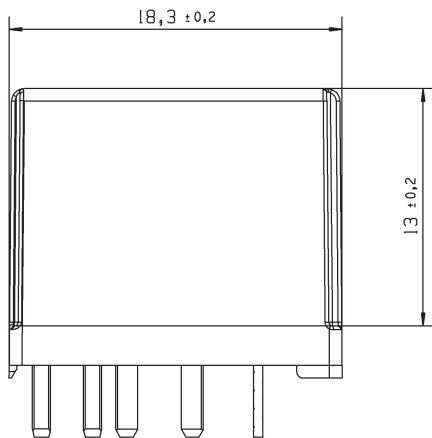

201L_DD2

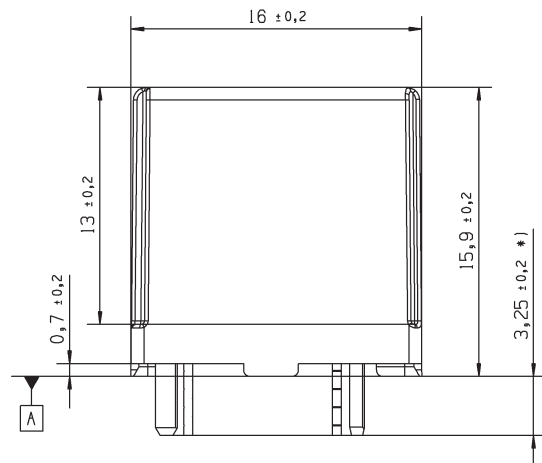

*) Additional tin tops max. 1mm

201L_DD1

Power Relay PK2 Latching (THT – THR) (Continued)

View of the terminals
Bottom view on solder pins

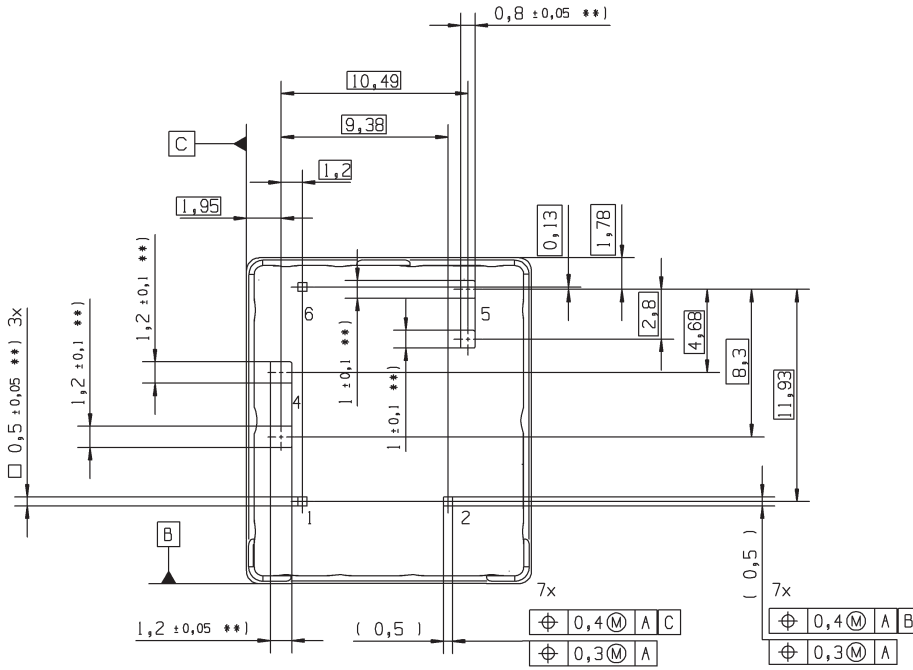

Remark: Positional tolerances according to DIN EN ISO 5458
**) without tinning (hot dip)

Product code structure	Typical product code V23201 -L 1 004 -A 5 02						
Type	PK2 Power Relay PK2 Latching (THT – THR)						
Terminal and enclosure	L Latching (sealed)	T Latching (vented)					
Design	1 Single relay						
Coil	004 12VDC (THT)	006 12VDC (THR)					
Contact type	A Single contact						
Contact material	5 AgSnO ₂						
Contact arrangement	02 1 form A, 1 NO						

Product code	Terminal/Encl.	Design	Coil	Cont. material	Arrangement	Part number
V23201-L1004-A502	PCB, sealed	Single relay	Latching (THT)	AgSnO ₂	1 form A, 1 NO	4-1414915-9
V23201-T1006-A502	PCB, vented		Latching (THR)			1-1414974-3

This list represents the most common types and does not show all variants covered by this datasheet.
Other types on request.