

## **R1025 10A, 80V Microstepping Driver** *"The PowerHouse"*

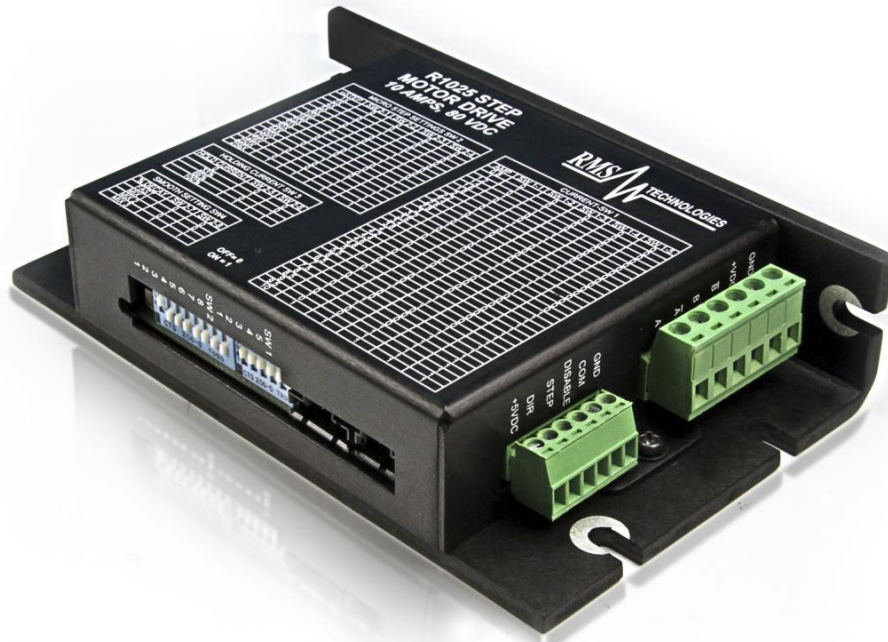

### **User Manual** Version 1.00

---

RMS Technologies  
2533 N. Carson St. #4698, Carson City, NV 89706-0147

Thank you for purchasing the R1025 Single-Axis Step & Direction Driver. This product is warranted to be free of manufacturing defects for one (1) year from the date of purchase.

### **PLEASE READ BEFORE USING**

Before you start, you must have a suitable step motor, a DC power supply suitable for the motor. The power supply voltage must be between 4 times and 20 times the motor's rated voltage.

### **DISCLAIMER**

The information provided in this document is believed to be reliable. However, no responsibility is assumed for any possible inaccuracies or omissions. Specifications are subject to change without notice.

RMS Technologies reserves the right to make changes without further notice to any products herein to improve reliability, function, or design. RMS Technologies does not assume any liability arising out of the application or use of any product or circuit described herein; neither does it convey any license under its patent rights, nor the rights of others.

### **Special Symbols**



**Indicates a WARNING and that this information could prevent injury, loss of property, or even death (in extreme cases).**

## R1025 User Manual

Product: R1025  
Version: 1.00  
Date: 10/02/2012

Version History		
Version	Date	Description of Changes
1.00	10/02/2012	New User Manual

# Table of Contents

<b>1. FEATURES.....</b>	<b>5</b>
<b>2. ELECTRICAL/OPERATING SPECIFICATIONS .....</b>	<b>5</b>
<b>3. MECHANICAL SPECIFICATIONS .....</b>	<b>6</b>
<b>4. PIN DESCRIPTIONS .....</b>	<b>7</b>
<b>5. DIP SWITCH SETTINGS .....</b>	<b>8-9</b>
<b>6. CONNECTION DIAGRAMS.....</b>	<b>10-11</b>
<b>7. TROUBLESHOOTING .....</b>	<b>12</b>
<b>8. APPENDIX A: RECCOMENDED CABLE .....</b>	<b>13-14</b>

## 1. FEATURES

- Single Axis Driver for Bipolar step motors
- Operates from +12 to 80 VDC
- Phase currents from 0.8 to 10 Amp Peak
- Adjustable Hold Current settings
- Selectable Step Resolution from Full Step to 256x Microstepping
- Has three optically isolated control inputs
- Four different Smooth Settings to optimize motor accuracy



## 2. ELECTRICAL SPECIFICATIONS

CHARACTERISTICS	MIN	MAX	UNITS
Operating Temperature	-20	85	°C
Supply Voltage	12	80	VDC
Phase Current	0.8	10	A
Logic Voltage	3	24	VDC
Logic Current		20	mA
5V Output Current		80	mA
Step Frequency		1	MHz
Step Pulse Width	250		ns

### 3. MECHANICAL SPECIFICATIONS

- Size: 5.56" x 3.46" x 1.24"
- Weight: 8.8 oz
- Mounting: Four M3x0.5 – 6H screws
- Plate: Aluminum, Hard Anodized

#### Dimensions

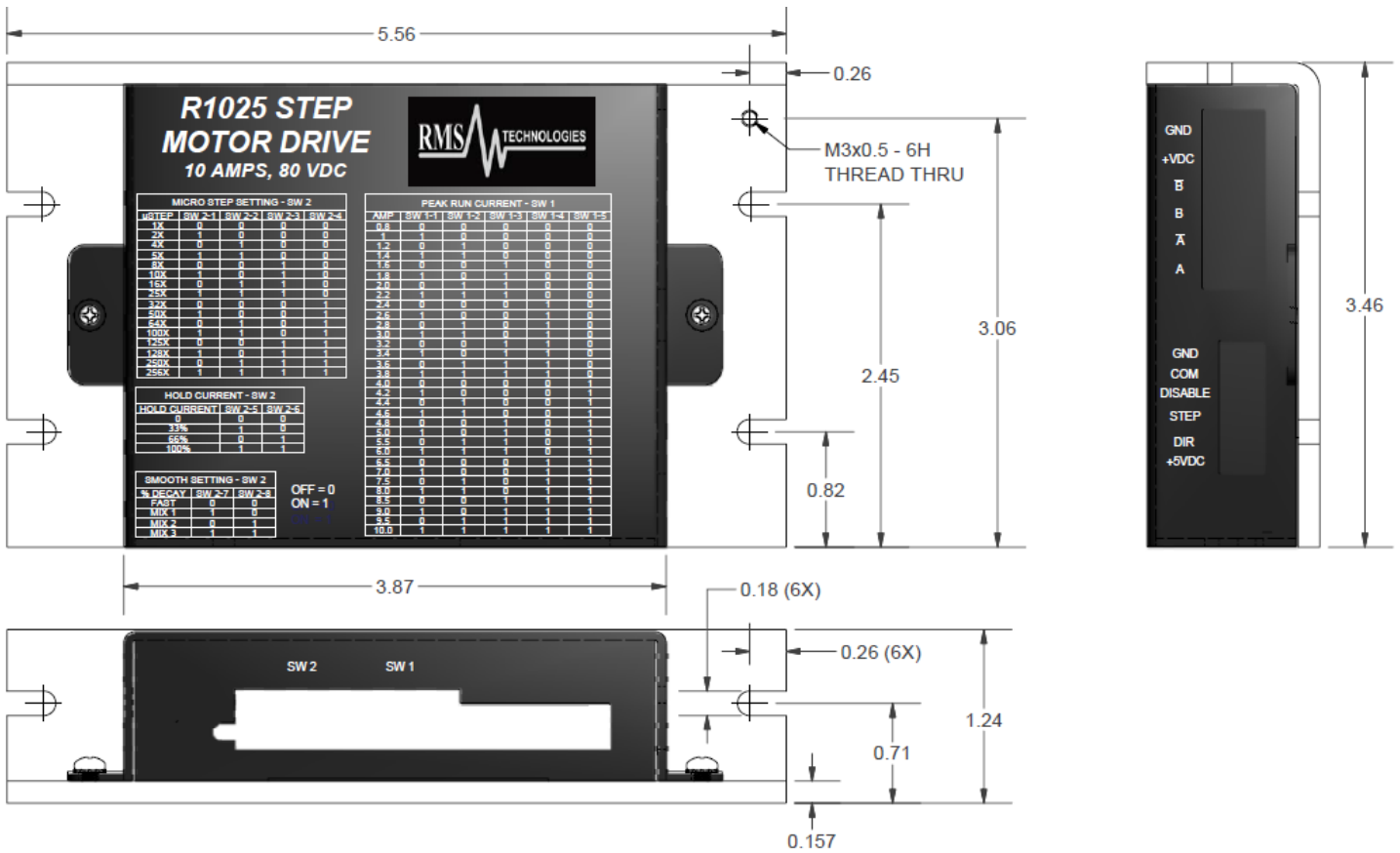

## 4. PIN DESCRIPTION

6-pin pluggable terminal strip connectors are used for the Optically Isolated **Logic Input** connections and **Power/Motor** connections. **Refer to Connector Tables below for Pin Functions.**

Logic Connector		
Pin Name	Description	Electrical Specs
<b>GND</b>	Logic GND.	GND
<b>COM</b> (Input)	Opto Common input. Used to Optically Isolate the Input when a separate supply is connected. Connecting the +5VDC will make the Inputs Functional but the Inputs will NOT be Isolated. <b>Note COM needs to be powered either by a separate supply or the +5VDC Pin in order for the Input/Outputs to function.</b>	Voltage: 3 - 24 VDC Max Current: 20mA
<b>DISABLE</b> (Input)	Used to Disable drive. <b>Active Low.</b> A closed connection to GND will Disable the drive. This is a Sink or Source Input.	Voltage: 3 - 24 VDC Max Current: 20mA
<b>STEP</b> (Input)	The Step output from a Pulse Generator is Input into this pin. Both an NPN and a PNP type PLC can be used for this input. <b>Refer to Connection Diagrams for help.</b>	Voltage: 3 - 24 VDC Max Current: 20mA
<b>DIR</b> (Input)	Used to switch Direction of motor. <b>Active Low.</b> A closed connection to GND will change direction. This is a Sink or Source Input.	Voltage: 3 - 24 VDC Max Current: 20mA
<b>+5VDC</b> (Output)	Internal +5VDC Output. If Optical Isolation is not desired then it can be connected to COM Pin. <b>DO NOT USE FOR EXTERNAL CIRCUITRY!</b>	Voltage: 5VDC Max Current: 80mA

Power/Motor Connector		
Pin Name	Description	Electrical Specs
<b>GND</b>	GND. Connect the <b>Negative</b> end of Power Supply here	GND
<b>+VDC</b>	Power. Connect <b>Positive</b> end of Power Supply here. <b>DO NOT EXCEED MAX VOLTAGE RATING OF 80VDC!</b>	Voltage Input: 12 - 80VDC
<b>-B</b>	Phase B Bar Motor Connection	Phase currents from 0.8 to 10A Peak Current Chopping Frequency: 22KHz
<b>B</b>	Phase B Motor Connection	Phase currents from 0.8 to 10A Peak Current Chopping Frequency: 22KHz
<b>-A</b>	Phase A Bar Motor Connection	Phase currents from 0.8 to 10A Peak Current Chopping Frequency: 22KHz
<b>A</b>	Phase A Motor Connection	Phase currents from 0.8 to 10A Peak Current Chopping Frequency: 22KHz



**CAUTION:** Connecting Motor phases (A, A Bar, B, B Bar) to the incorrect location while the R1025 is powered will cause the board to burn. Be sure to insert motor phases into Pins 6 through 9, in the order of A, A Bar, B, and B Bar. It is recommended that power is connected last, so that all connections can be checked before power

## 5. DIP SWITCH SETTINGS

**Switch 1 (SW1)** controls the **Peak Run Current** that is output to the Motor. **Ensure the Run Current IS NOT greater than the Motors Peak Current. Motor Peak Current = Motors Rated Current \* 1.4**  
**Default Settings in GREEN**

Run Current - SW1					
AMP(S)	SW 1-1	SW 1-2	SW 1-3	SW 1-4	SW 1-5
<b>0.8</b>	<b>OFF</b>	<b>OFF</b>	<b>OFF</b>	<b>OFF</b>	<b>OFF</b>
1	ON	OFF	OFF	OFF	OFF
1.2	OFF	ON	OFF	OFF	OFF
1.4	ON	ON	OFF	OFF	OFF
1.6	OFF	OFF	ON	OFF	OFF
1.8	ON	OFF	ON	OFF	OFF
2	OFF	ON	ON	OFF	OFF
2.2	ON	ON	ON	OFF	OFF
2.4	OFF	OFF	OFF	ON	OFF
2.6	ON	OFF	OFF	ON	OFF
2.8	OFF	ON	OFF	ON	OFF
3	ON	ON	OFF	ON	OFF
3.2	OFF	OFF	ON	ON	OFF
3.4	ON	OFF	ON	ON	OFF
3.6	OFF	ON	ON	ON	OFF
3.8	ON	ON	ON	ON	OFF
4	OFF	OFF	OFF	OFF	ON
4.2	ON	OFF	OFF	OFF	ON
4.4	OFF	ON	OFF	OFF	ON
4.6	ON	ON	OFF	OFF	ON
4.8	OFF	OFF	ON	OFF	ON
5	ON	OFF	ON	OFF	ON
5.5	OFF	ON	ON	OFF	ON
6	ON	ON	ON	OFF	ON
6.5	OFF	OFF	OFF	ON	ON
7	ON	OFF	OFF	ON	ON
7.5	OFF	ON	OFF	ON	ON
8	ON	ON	OFF	ON	ON
8.5	OFF	OFF	ON	ON	ON
9	ON	OFF	ON	ON	ON
9.5	OFF	ON	ON	ON	ON
10	ON	ON	ON	ON	ON



**Switch 2 (SW2)** controls the **Micro Step Settings**, **Holding Current**, and **Smooth Setting**. It is recommended to set the switches to desired settings before power up.

MICRO STEP SETTINGS - SW2				
uSTEP	SW 2-1	SW 2-2	SW 2-3	SW 2-4
1X	OFF	OFF	OFF	OFF
2X	ON	OFF	OFF	OFF
4X	OFF	ON	OFF	OFF
5X	ON	ON	OFF	OFF
8X	OFF	OFF	ON	OFF
10X	ON	OFF	ON	OFF
16X	OFF	ON	ON	OFF
25X	ON	ON	ON	OFF
32X	OFF	OFF	OFF	ON
50X	ON	OFF	OFF	ON
64X	OFF	ON	OFF	ON
100X	ON	ON	OFF	ON
125X	OFF	OFF	ON	ON
128X	ON	OFF	ON	ON
250X	OFF	ON	ON	ON
256X	ON	ON	ON	ON

Hold Current - SW2		
Hold Current	SW 2-5	SW 2-6
0	OFF	OFF
33%	ON	OFF
66%	OFF	ON
100%	ON	ON

Smooth Setting - SW2		
%Decay	SW 2-7	SW 2-8
Fast	OFF	OFF
Mix 1	ON	OFF
Mix 2	OFF	ON
Mix 3	ON	ON

## 6. CONNECTION DIAGRAMS

### PLC to R1025 WITH Opto-Isolation

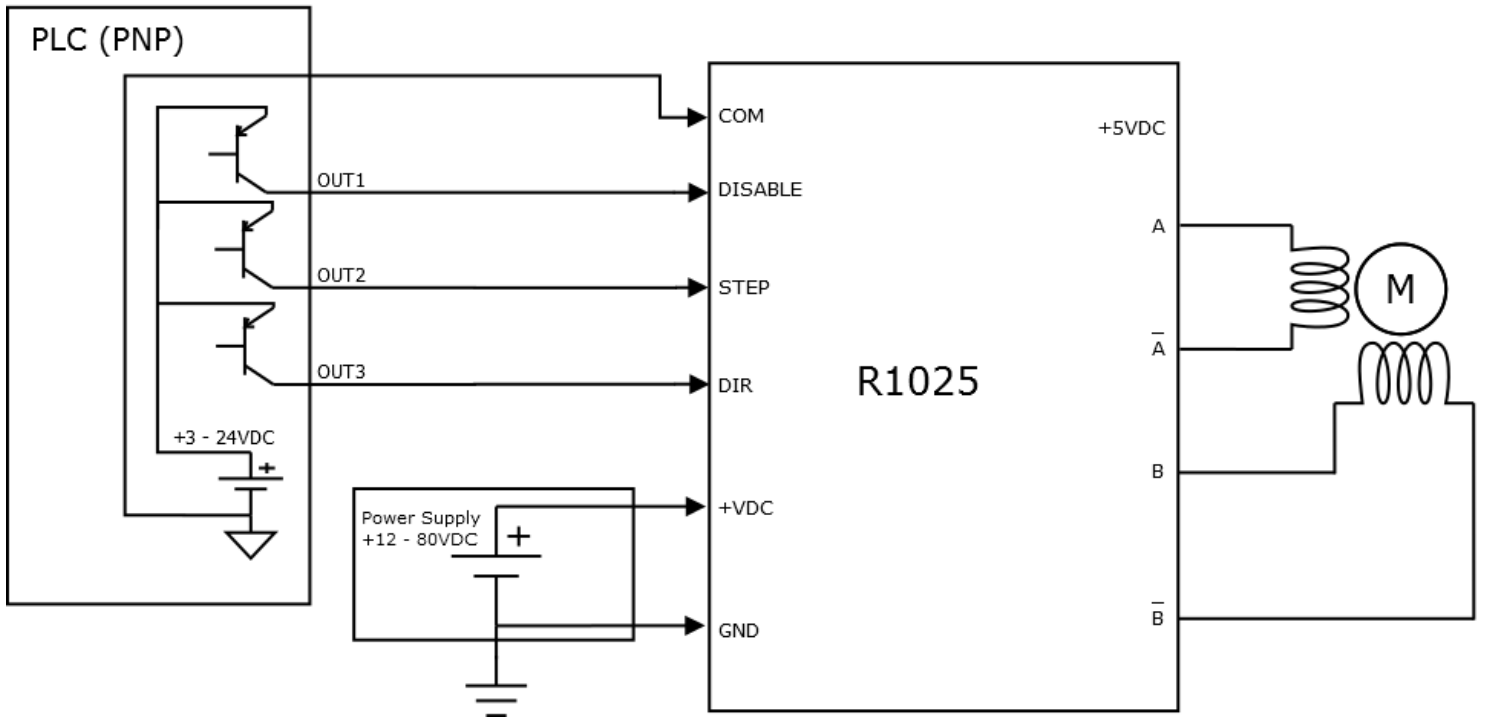
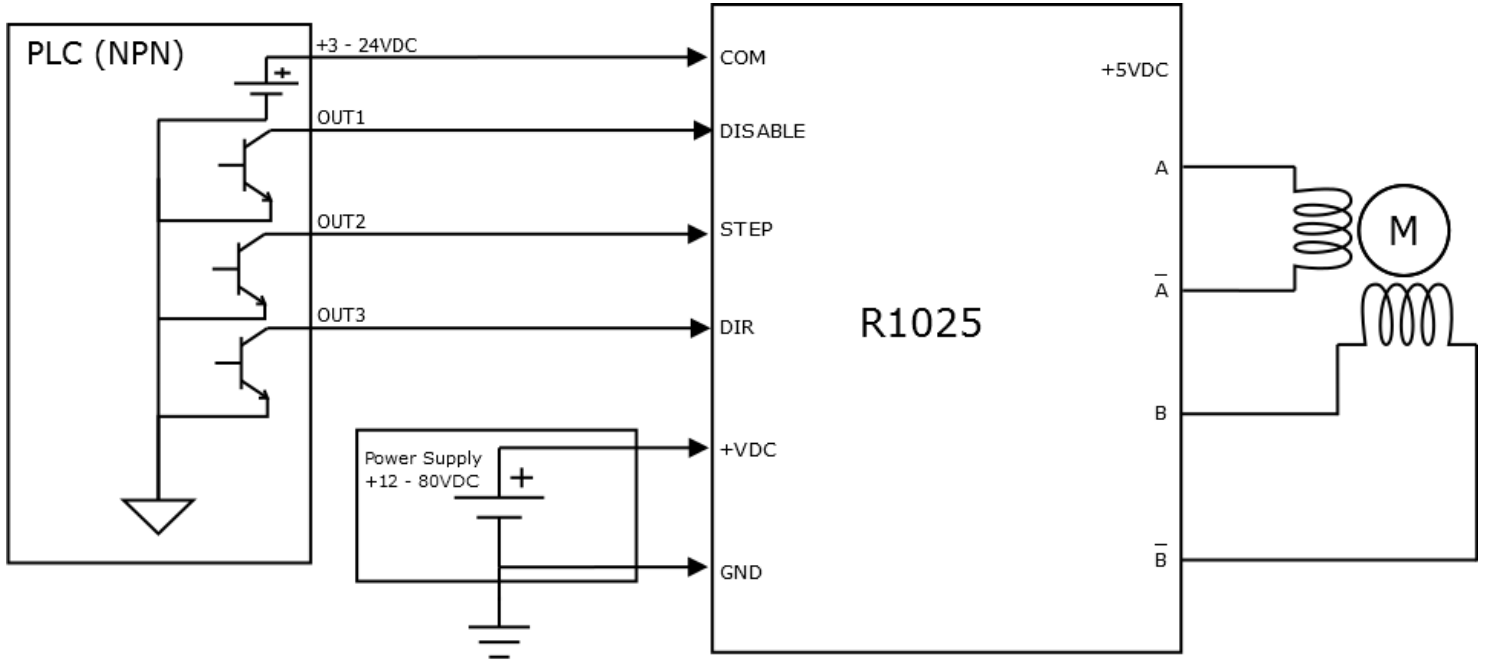

**PLC to R1025 WITH NO Opto-Isolation**

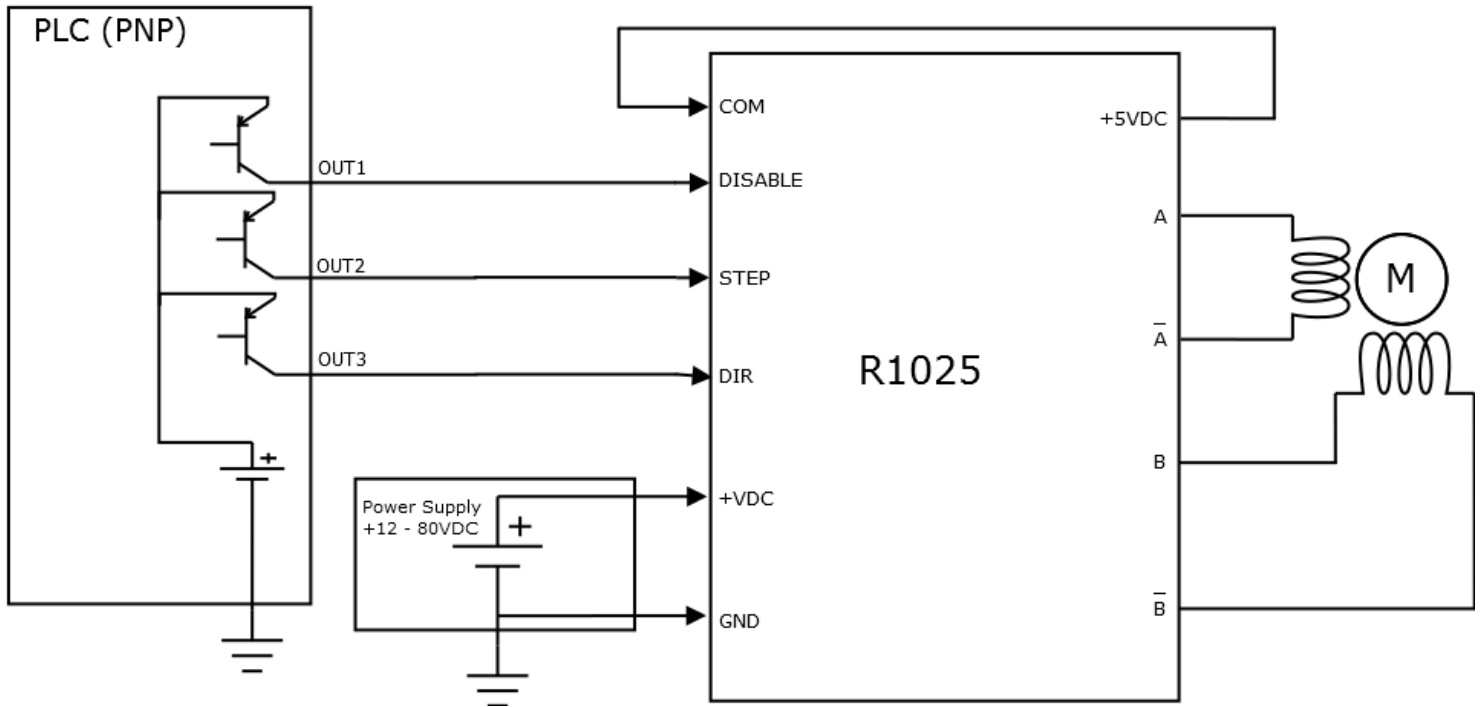
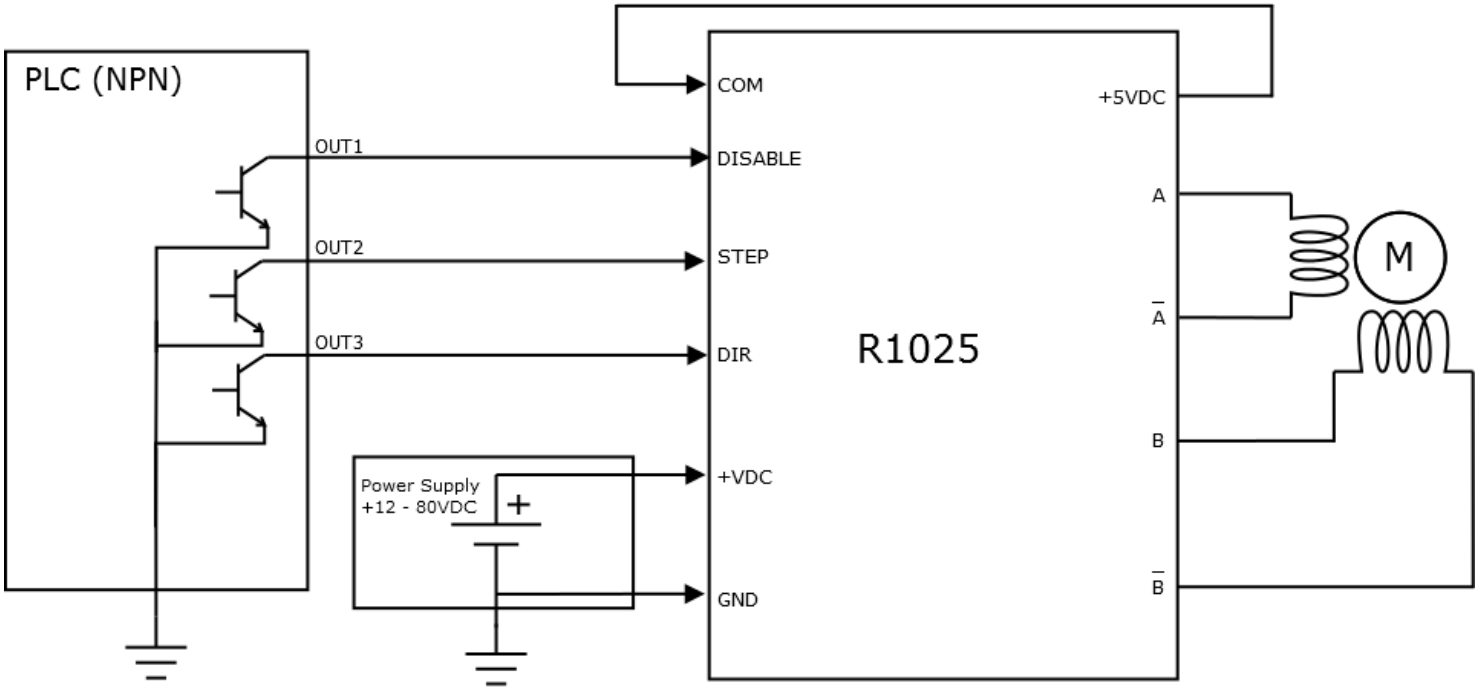

## **7. Troubleshooting**

### **R1025 not moving the motor (Step/Dip)**

Verify that the 5V is being supplied to the **COM** Pin.

### **The R1025 is causing the motor to vibrate and jitter back and forth**

Are the Motor phases switched? Be sure to check that motor wires are connected to **Pins A, A Bar, B, B Bar**. To check which wires belong to one phase, take a Meter to measure resistance between any two wires to ensure there is a finite value between them; first probe between the A and A BAR pins then the B and B BAR pins.

### **Technical Support**

**By Telephone: 408-919-0200**

**(Monday - Friday, 8:00 a.m.-5:00 p.m.)**

**On the Web: [www.linengineering.com](http://www.linengineering.com)**

Our technical support group is glad to work with you in answering your questions. If you cannot find the solution to your particular application, or, if for any reason you need additional technical assistance, please call technical support at **408-919-0200**.

## **8. Appendix A: Recommended Cable**

### ***Recommended Cable Configurations: DC Supply to Driver***

Cable length, wire gauge and power conditioning devices play a major role in the performance of your RMS Technologies Driver and Motor.

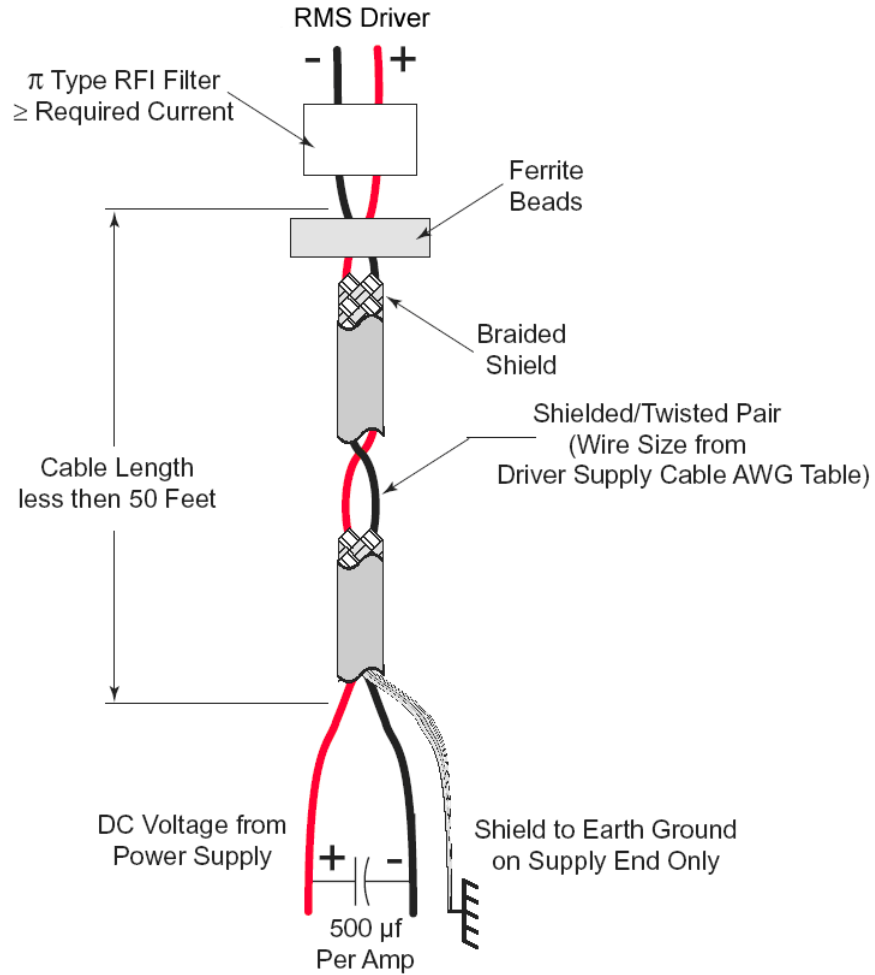

Example A – Cabling Under 50 Feet, DC Power

Example A demonstrates the recommended cable configuration for DC power supply cabling under 50 feet long. If cabling of 50 feet or longer is required, the additional length may be gained by adding an AC power supply cable.

## Recommended Cable Configurations: Driver to Motor

Cable length, wire gauge and power conditioning devices play a major role in the performance of your Driver and Motor.

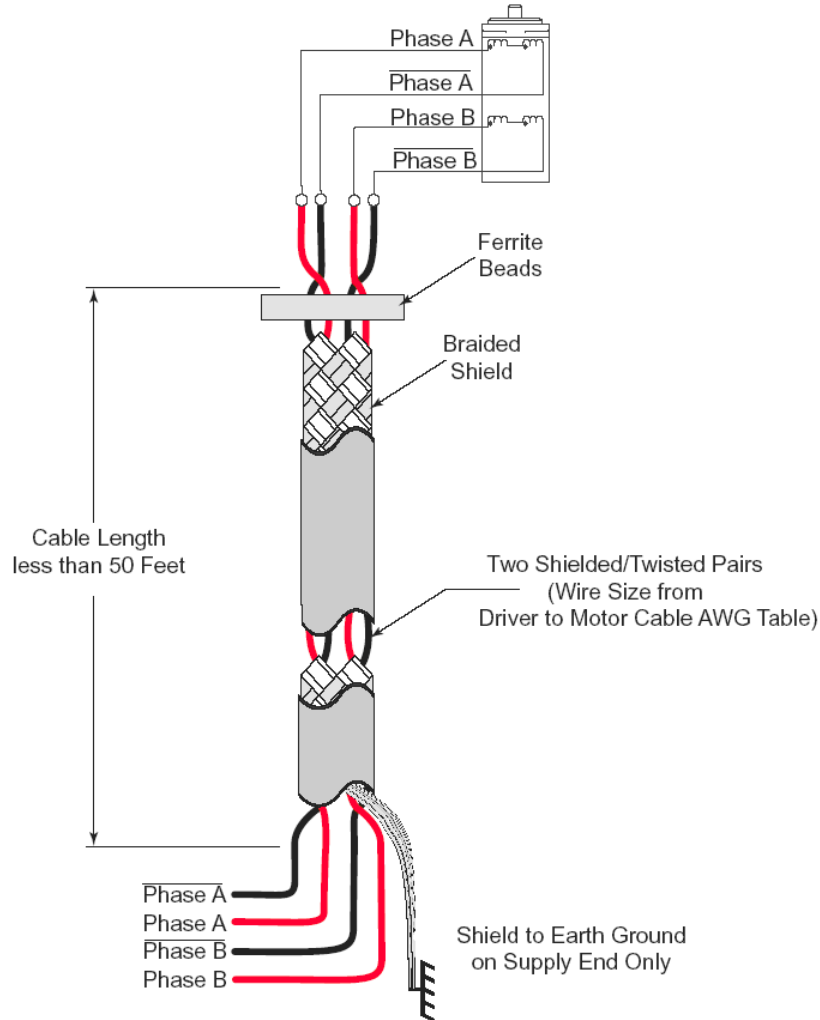

Example A - Cabling Under 50 Feet, Driver to Motor