

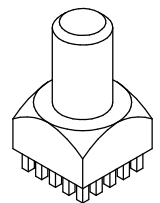

Surface coating 5-10µm Sn on 2-4µm Cu

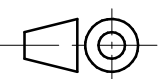

(1:1)

(PROJECTION) 		(TOLERANCES) DIN ISO 2768-m		(SURFACE)		SCALE	2:1	TOTAL WEIGHT: 16,8 g
						(MATERIAL)	CuZn39Pb3	WEIGHT Cu: 0,0368 g
						(TITLE)	Threaded shank M8 full plain Pin-Plate	
						(DRAWING NUMBER)	7460719	Sheet 1
ISSUE	CHANGE	DATE	NAME					1
						CONFIDENTIAL !! ALL RIGHTS RESERVED. Passing on or duplication without prior written agreement prohibited.		