

Cree® LMH2 LED Modules

LMH2 Light Source with Flat Lens



LMH2 Light Source with Dome Lens



PRODUCT DESCRIPTION

Cree LED modules provide lighting designers and manufacturers with simple, easy-to-adopt LED lighting solutions that reduce luminaire development time and speed time-to-market. Cree LMH2 LED modules are the ideal choice for enabling rapid luminaire development where bright, beautiful, long-life lighting is required. The ease of use of the LMH series of modules enables this versatile LED lighting module to jump-start the design process for recessed downlights, wall sconces or pendant lights in demanding end markets such as retail, museums, hospitality, restaurants and studio lighting.

FEATURES

- Industry-leading light-source efficacy of 97 lm/W (steady state) for 800-3000 lm, 108 lm/W (steady state) for 4000 lm
- Available in 2700 K, 3000 K, 3500 K and 4000 K CCT
- ≥ 90 CRI for all CCTs
- Minimum 95 CRI available for 3500 K at 3000 lm
- Broad selection of mounting and wiring options
- Industry-leading 5-year limited system warranty
- Designed to last 50,000 hours at L_{70}
- No UV in light output
- No mercury in light source

TABLE OF CONTENTS

Characteristics	2
Order Codes - 90 CRI.....	3
Order Code - 95 CRI.....	3
Thermal Management Guidelines	4
Relative Spectral Power Distribution .	5
Relative Luminous Flux vs. Case Temperature	5
Typical Voltage vs. Case Temperature	6
Notes.....	6
Photometry.....	7
Performance Groups - Chromaticity..	9
Chromaticity Bins Plotted on the 1931 CIE Color Space	9
Mechanical Dimensions	10
Packaging.....	11

CHARACTERISTICS

Characteristics	Unit	Minimum	Typical	Maximum
Viewing angle (FWHM) - 850- & 1250-lm flat lens	degrees		82	
Viewing angle (FWHM) - 850- & 1250-lm dome lens	degrees		96	
Viewing angle (FWHM) - 2000- & 3000-lm flat lens	degrees		82	
Viewing angle (FWHM) - 2000- & 3000-lm dome lens	degrees		105	
Viewing angle (FWHM) - 4000-lm flat lens	degrees		85	
Viewing angle (FWHM) - 4000-lm dome lens	degrees		105	
DC forward current - 850 & 1250 lm	mA	400	440	480
DC forward current - 2000 & 3000 lm	mA	810	900	990
DC forward current - 4000 lm	mA	850	940	1030
Forward voltage - 850 lm (@ 440 mA, 55 °C)	V		19.9	21.2
Forward voltage - 1250 lm (@ 440 mA, 55 °C)	V		29.3	31.6
Forward voltage - 2000 lm (@ 900 mA, 55 °C)	V		22.9	24.7
Forward voltage - 3000 lm (@ 900 mA, 55 °C)	V		34.4	37.0
Forward voltage - 4000 lm (@ 940 mA, 55 °C)	V		39.7	42.7
Luminous flux - 850-lm flat lens(@ 440 mA, 55 °C)	lm	790	850	909
Luminous flux - 1250-lm flat lens (@ 440 mA, 55 °C)	lm	1163	1250	1337
Luminous flux - 2000-lm flat lens (@ 900 mA, 55 °C)	lm	1860	2000	2140
Luminous flux - 3000-lm flat lens (@ 900 mA, 55 °C)	lm	2790	3000	3210
Luminous flux - 4000-lm flat lens (@ 940 mA, 55 °C)	lm	3720	4000	4280
LED module case temperature (Tc)	°C	0		70
CRI - 90 CRI	100-point scale	90		
CRI - 95 CRI	100-point scale	95		

Notes:

- LMH2 modules are not designed for reverse bias operation.
- Cree maintains a tolerance of $\pm 7\%$ on flux measurements, $\pm 10\%$ on power measurements, ± 0.005 on chromaticity (CCx, CCy) measurements and a tolerance of ± 2 on CRI measurements.
- 55 °C measured at case temperature (Tc) point shown on page 10.
- Luminous flux values for the dome lens LMH2 LED module can be up to 3% higher.

ORDER CODES - 90 CRI

Typical Luminous Flux (lm)	Typical Light Source Efficacy (lm/W)	CCT (K)	Order Code	
			Flat Lens	Dome Lens
850	97	4000	LMH020-0850-40G9-00000TW	LMH020-0850-40G9-00001TW
		3500	LMH020-0850-35G9-00000TW	LMH020-0850-35G9-00001TW
		3000	LMH020-0850-30G9-00000TW	LMH020-0850-30G9-00001TW
		2700	LMH020-0850-27G9-00000TW	LMH020-0850-27G9-00001TW
1250	97	4000	LMH020-1250-40G9-00000TW	LMH020-1250-40G9-00001TW
		3500	LMH020-1250-35G9-00000TW	LMH020-1250-35G9-00001TW
		3000	LMH020-1250-30G9-00000TW	LMH020-1250-30G9-00001TW
		2700	LMH020-1250-27G9-00000TW	LMH020-1250-27G9-00001TW
2000	97	4000	LMH020-2000-40G9-00000TW	LMH020-2000-40G9-00001TW
		3500	LMH020-2000-35G9-00000TW	LMH020-2000-35G9-00001TW
		3000	LMH020-2000-30G9-00000TW	LMH020-2000-30G9-00001TW
		2700	LMH020-2000-27G9-00000TW	LMH020-2000-27G9-00001TW
3000	97	4000	LMH020-3000-40G9-00000TW	LMH020-3000-40G9-00001TW
		3500	LMH020-3000-35G9-00000TW	LMH020-3000-35G9-00001TW
		3000	LMH020-3000-30G9-00000TW	LMH020-3000-30G9-00001TW
		2700	LMH020-3000-27G9-00000TW	LMH020-3000-27G9-00001TW
4000	108	4000	LMH020-4000-40G9-00000TW	LMH020-4000-40G9-00001TW
		3500	LMH020-4000-35G9-00000TW	LMH020-4000-35G9-00001TW
		3000	LMH020-4000-30G9-00000TW	LMH020-4000-30G9-00001TW
		2700	LMH020-4000-27G9-00000TW	LMH020-4000-27G9-00001TW

ORDER CODE - 95 CRI

Typical Luminous Flux (lm)	Typical Light Source Efficacy (lm/W)	CCT (K)	Order Code
			Flat Lens
3000	97	3500	LMH020-3000-35GS-00000TW

THERMAL MANAGEMENT GUIDELINES

The Cree LMH2 module is designed to perform in a variety of environments without the need for active cooling. To achieve lifetime and performance estimates, and to maintain the warranty, the final luminaire design cannot allow the Tc point shown on page 10 to exceed 70 °C for the light source when the luminaire is at thermal equilibrium. Follow the mechanical and thermal design guidelines listed in the “Cree LMH2 LED Module Design Guide” to ensure proper thermal management.¹ Two optional heat sinks are available.

Optional Heat Sink 1²

Order code LMH020-HS00-0000-0000001

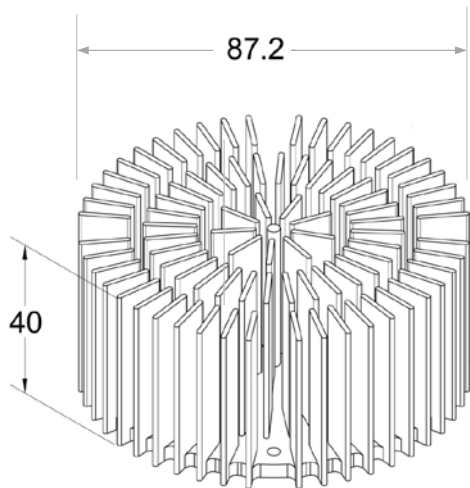

For use with LMH2-850, 1250, 2000, 3000

Optional Heat Sink 2

Order code LMH020-HS00-0000-0000002

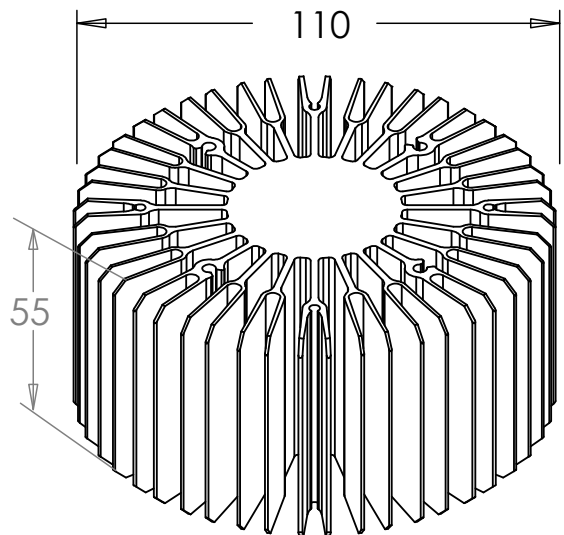

For use with LMH2-850, 1250, 2000, 3000, 4000

Note: Refer to the LMH2 Design Guide for more information on choosing the appropriate heat sink for a given application.

1 www.cree.com/modules_guides/lmh2

2 Dimensions for the diagrams are in mm and are for reference only. For exact dimensions and tolerances, refer to the 3-D models (.STEP file) for the optional heat sinks available by selecting the Documentation tab at www.cree.com/modules/lmh2.

RELATIVE SPECTRAL POWER DISTRIBUTION

Test Conditions: $I_f = 440$ mA: 850 & 1250 lm; $I_f = 900$ mA: 2000 & 3000 lm; $I_f = 940$ mA: 4000 lm; $T_c = 55$ °C; Steady-state operation

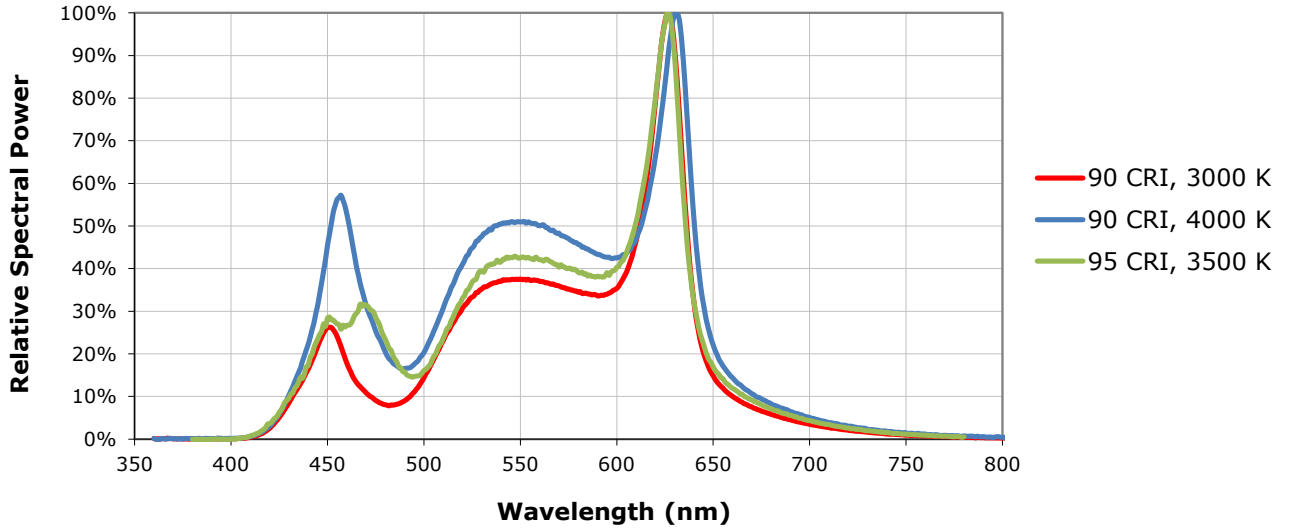

RELATIVE LUMINOUS FLUX VS. CASE TEMPERATURE

Test Conditions: $I_f = 440$ mA: 850 & 1250 lm; $I_f = 900$ mA: 2000 & 3000 lm; $I_f = 940$ mA: 4000 lm; Steady-state operation

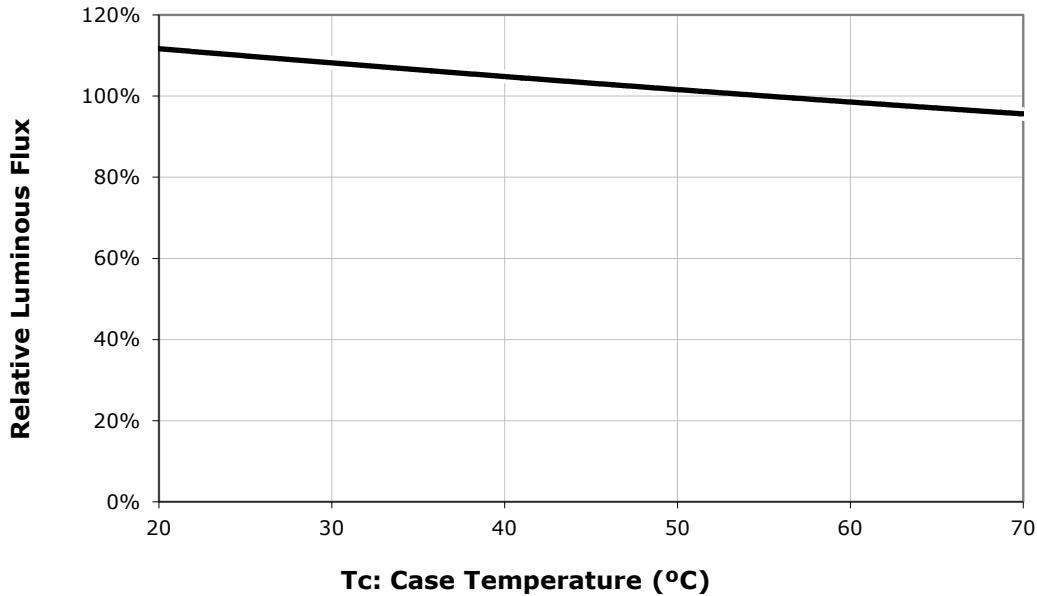

TYPICAL VOLTAGE VS. CASE TEMPERATURE

Test Conditions: $I_f = 440 \text{ mA}$: 850 & 1250 lm; $I_f = 900 \text{ mA}$: 2000 & 3000 lm; $I_f = 940 \text{ mA}$: 4000 lm; Steady-state operation

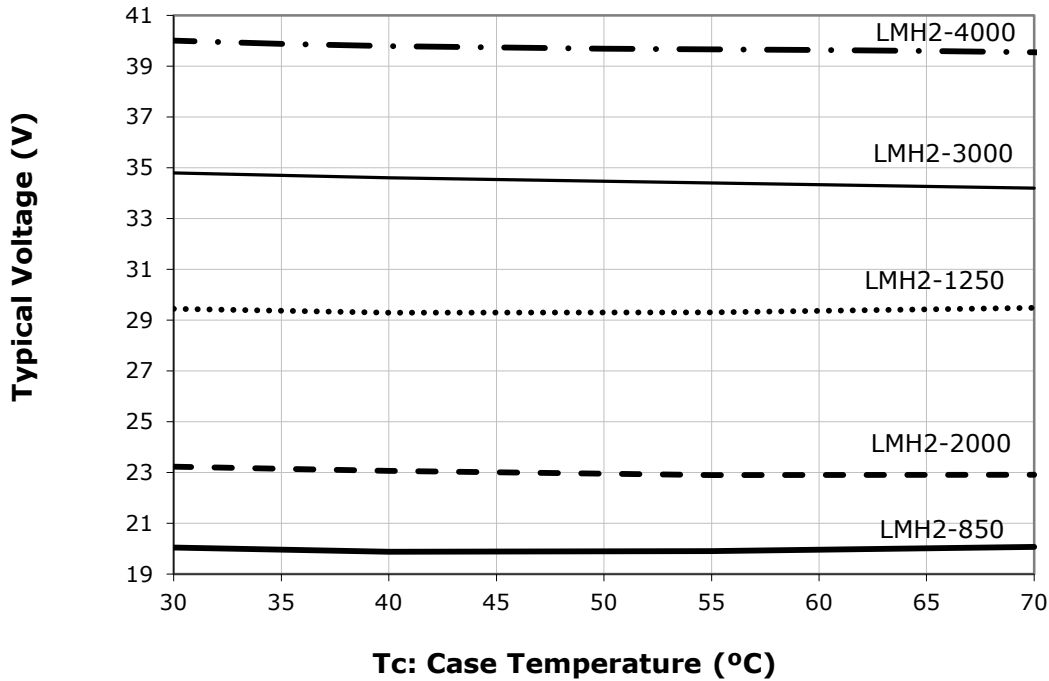

NOTES

RoHS Compliance

The levels of RoHS restricted materials in this product are below the maximum concentration values (also referred to as the threshold limits) permitted for such substances, or are used in an exempted application, in accordance with EU Directive 2011/65/EC (RoHS2), as amended through June 8, 2011. RoHS Declarations for this product can be obtained from your Cree representative or from the Product Ecology section of www.cree.com.

Vision Advisory Claim

Users should be cautioned not to stare at the light of this LED product. The bright light can damage the eye. See the Eye Safety application note at www.cree.com/xlamp_app_notes/led_eye_safety.

PHOTOMETRY

With Flat Lens

Intensity (Candlepower)

Angle	850	1250
0°	402	575
5°	399	571
15°	375	539
25°	331	479
35°	270	394
45°	202	297
55°	136	202
65°	79	118
75°	30	45
85°	3	5
90°	0	0

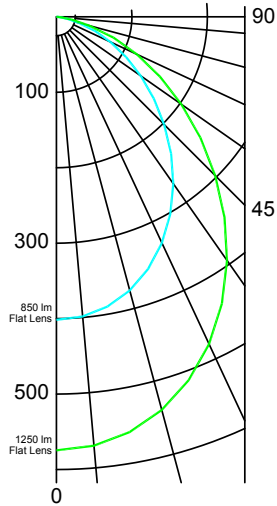

Zonal Lumens - 850

Zone	Lumens	%
0-30°	295	34
0-40°	464	54
0-60°	742	87
0-90°	858	100
0-180°	858	100

Zonal Lumens - 1250

Zone	Lumens	%
0-30°	426	34
0-40°	672	54
0-60°	1082	86
0-90°	1256	100
0-180°	1256	100

With Dome Lens

Intensity (Candlepower)

Angle	850	1250
0°	309	461
5°	307	457
15°	297	442
25°	272	405
35°	229	339
45°	177	262
55°	126	187
65°	84	124
75°	53	78
85°	34	50
90°	27	39

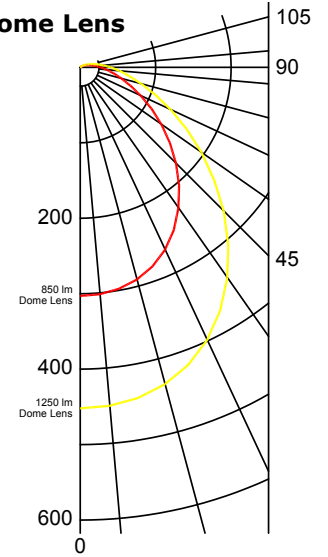

Zonal Lumens - 850

Zone	Lumens	%
0-30°	233	27
0-40°	375	44
0-60°	631	73
0-90°	818	95
0-180°	862	100

Zonal Lumens - 1250

Zone	Lumens	%
0-30°	349	27
0-40°	561	44
0-60°	945	73
0-90°	1224	95
0-180°	1289	100

Intensity (Candlepower)

Angle	2000	3000
0°	1043	1563
5°	1034	1551
15°	967	1456
25°	840	1263
35°	661	987
45°	464	688
55°	293	433
65°	166	245
75°	73	110
85°	11	17
90°	0	0

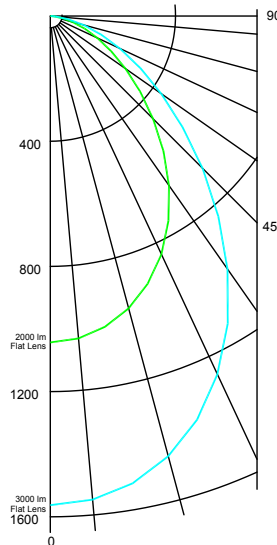

Zonal Lumens - 2000

Zone	Lumens	%
0-30°	755	37
0-40°	1168	57
0-60°	1790	87
0-90°	2049	100
0-180°	2049	100

Zonal Lumens - 3000

Zone	Lumens	%
0-30°	1136	37
0-40°	1752	57
0-60°	2673	87
0-90°	3058	100
0-180°	3058	100

Intensity (Candlepower)

Angle	2000	3000
0°	683	1008
5°	680	1003
15°	654	965
25°	603	890
35°	527	781
45°	435	645
55°	334	496
65°	237	354
75°	158	236
85°	101	153
90°	79	120

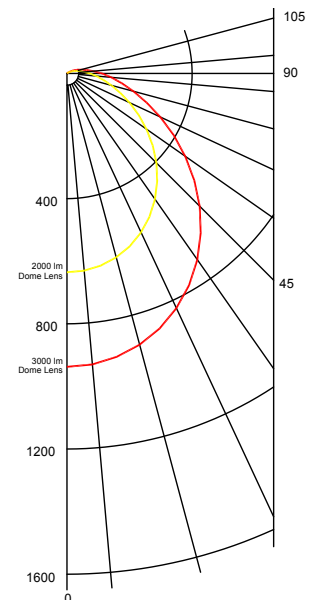

Zonal Lumens - 2000

Zone	Lumens	%
0-30°	527	25
0-40°	856	40
0-60°	1490	70
0-90°	2006	94
0-180°	2129	100

Zonal Lumens - 3000

Zone	Lumens	%
0-30°	777	25
0-40°	1266	40
0-60°	2207	70
0-90°	2977	94
0-180°	3165	100

PHOTOMETRY - CONTINUED

With Flat Lens

Intensity (Candlepower)

Angle	4000
0°	1996
5°	1981
15°	1861
25°	1626
35°	1286
45°	907
55°	575
65°	329
75°	151
85°	29
90°	0

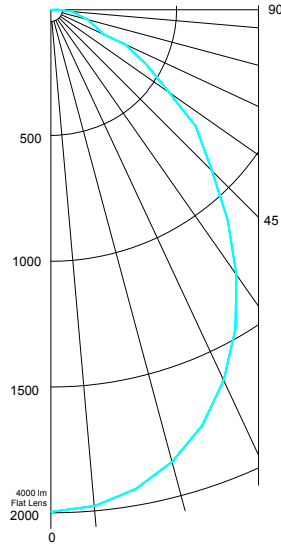

Zonal Lumens - 4000

Zone	Lumens	%
0-30°	1457	36
0-40°	2260	56
0-60°	3477	87
0-90°	4004	100
0-180°	4004	100

With Dome Lens

Intensity (Candlepower)

Angle	4000
0°	1414
5°	1407
15°	1357
25°	1249
35°	1080
45°	873
55°	656
65°	458
75°	301
85°	192
90°	151

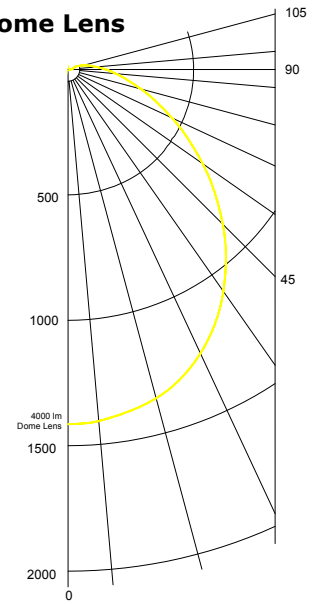

Zonal Lumens - 4000

Zone	Lumens	%
0-30°	785	18
0-40°	1422	33
0-60°	2751	64
0-90°	4030	94
0-180°	4275	100

PERFORMANCE GROUPS - CHROMATICITY

Test Conditions: $I_f = 440 \text{ mA}$: 850 & 1250 lm; $I_f = 900 \text{ mA}$: 2000 & 3000 lm; $I_f = 940 \text{ mA}$: 4000 lm; $T_c = 55 \text{ }^\circ\text{C}$; Steady-state operation

LMH2 modules are tested for chromaticity and placed into one of the regions defined by the following bounding coordinates. LMH2 modules will remain within their target ANSI C78.377A bin as long as the operating limits listed in the Characteristics section on page 2 are followed.

Code	ccx	ccy
27G	0.4499	0.4053
	0.4584	0.4177
	0.4657	0.4148
	0.4571	0.4025
30G	0.4261	0.3984
	0.4341	0.4106
	0.4416	0.4077
	0.4335	0.3956

Code	ccx	ccy
35G	0.3999	0.3872
	0.4073	0.3991
	0.4149	0.3963
	0.4073	0.3846
40G	0.3891	0.3842
	0.3814	0.3868
	0.3746	0.3754
	0.3821	0.3729

CHROMATICITY BINS PLOTTED ON THE 1931 CIE COLOR SPACE

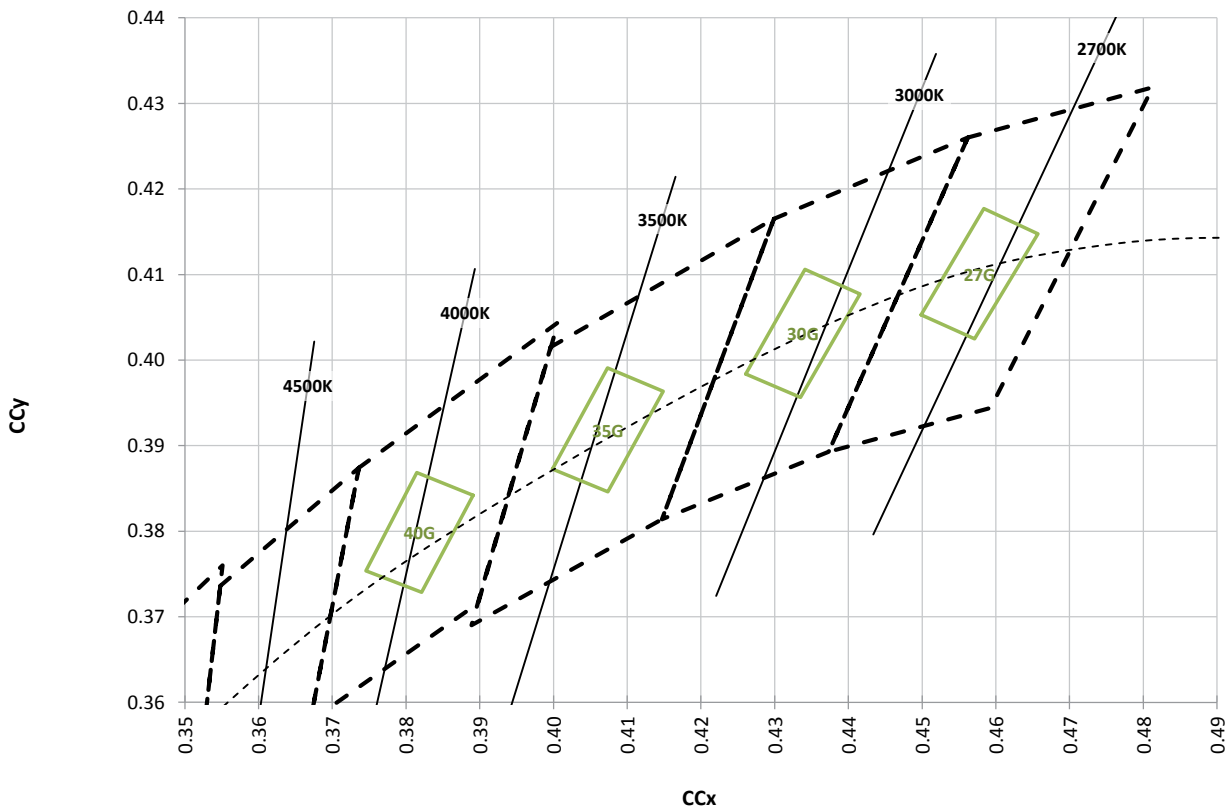

MECHANICAL DIMENSIONS³

LMH2 Light Source (Flat Lens)

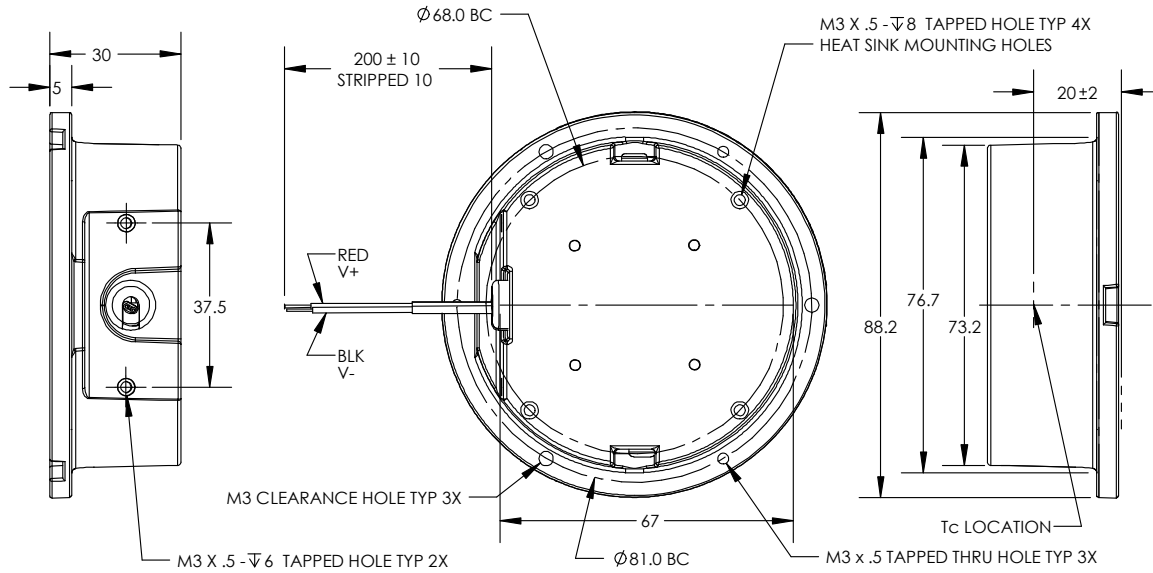

LMH2 Light Source (Dome Lens)

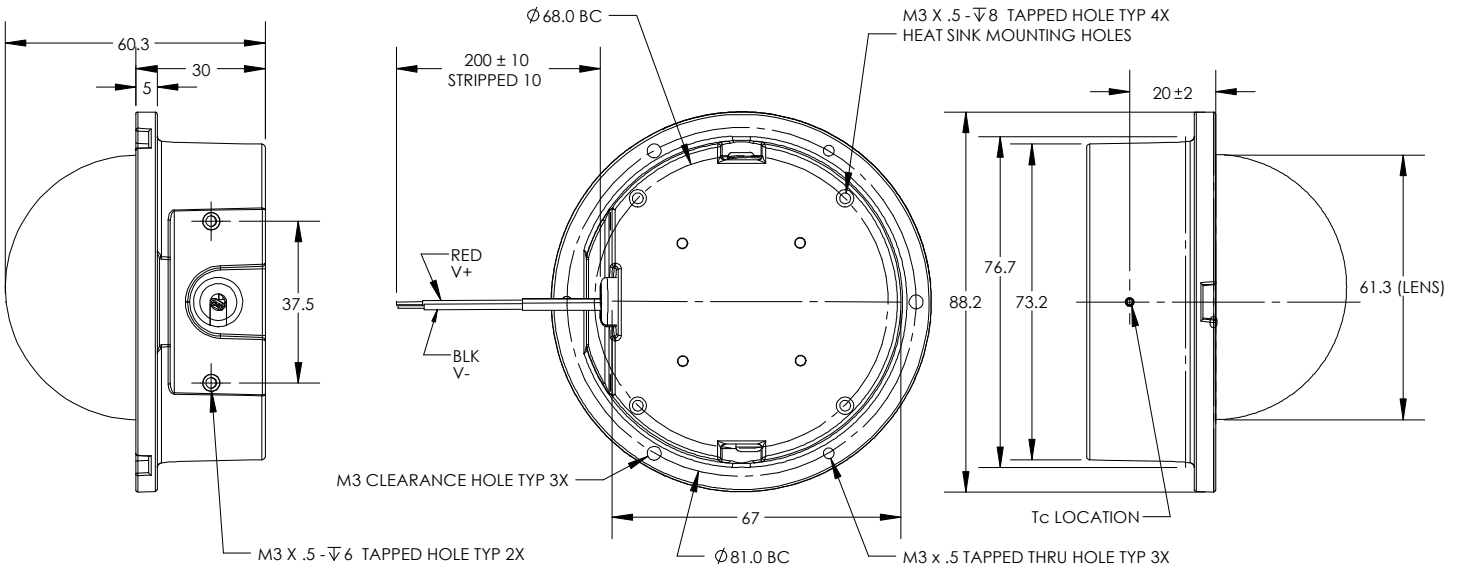

³ Dimensions for the diagrams are in mm and are for reference only. For exact dimensions and tolerances, refer to the 3-D models (.STEP files) for the LMH2 light sources available by selecting the Documentation tab at www.cree.com/modules/lmh2.

PACKAGING

LMH2 light sources are packaged in boxes of 10, which are then combined in cartons of 5 boxes, or 50 LMH2 light sources. Box and carton sizes are as follows.

Box of 10 LMH2 light sources: 321 x 281 x 116 mm

Carton of 5 LMH2 boxes: 599 x 299 x 347 mm