



Solid State Timers and Controllers

438USA-X Special Universal Switch Adjustable Time Capsule®



The popularity of the original Model 438USA generated the requirements for Universal Switch Adjustable models with both shorter and extended timing ranges, along with special operating voltages. The model 438USA-X performs exactly as the 438USA, but with both timing and voltage ranges specified. By merely connecting the two terminals in series with any load circuit drawing between ten milliamperes and one ampere operating from the specified voltage range, the 438USA-X turns that load circuit into a delay on make timing circuit. Set the 10 DIP switches to the required delay, and apply operating voltage. "X" is replaced with a digit from 1 to 4 (see *Ordering Information*).

Mechanical & Wiring

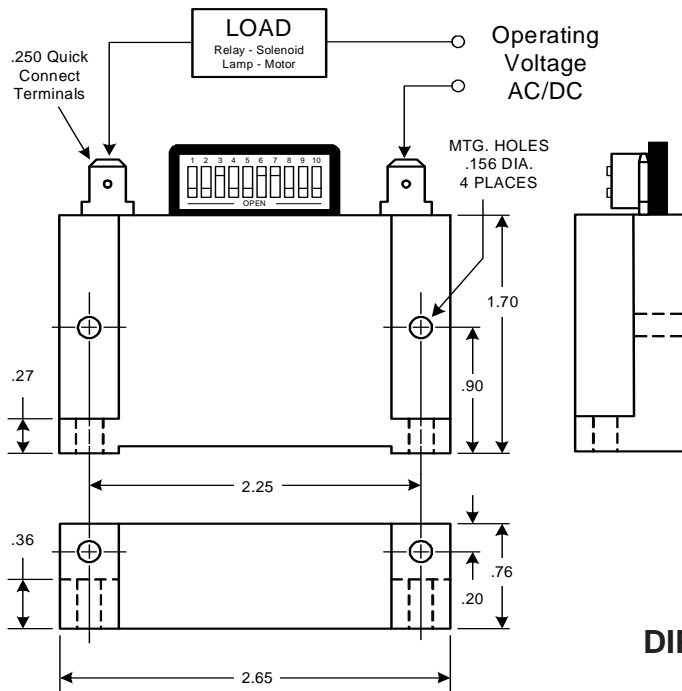

Timing Diagram

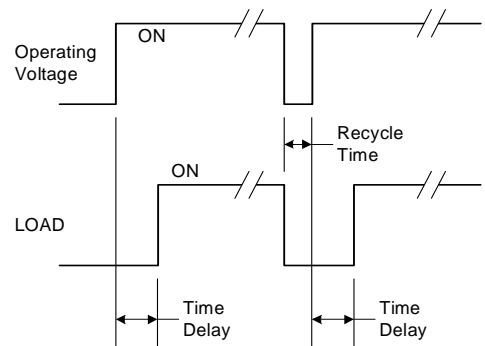

Setting the DIP Switches

The DIP switches are used to set the time delay period between 0.1 and 102.4 seconds for models 438USA-1, -2, & -3, and between 2 and 2048 seconds for the model 438USA-4. The 438USA-1, -2, & -3 models have an internal 0.1 second delay, and the 438USA-4 has an internal delay of 2 seconds. To set any desired time delay, open the switches whose total value is equal to the desired time delay minus the internal delay value. See the next page for a detailed example. The chart to the right shows the DIP switch values for the various models

DIP Switch Values

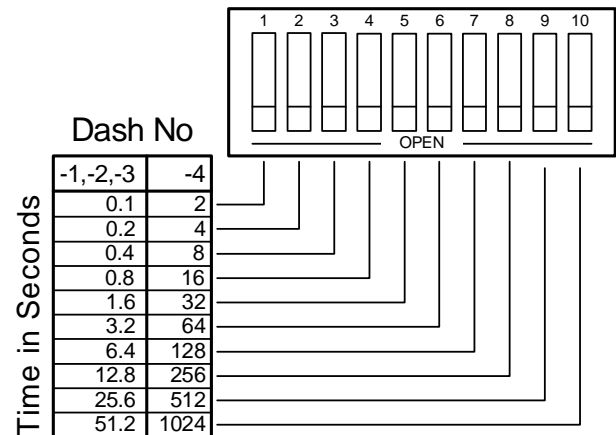

VISIT OUR WEB SITE AT: www.artisancontrols.com

Notice: Artisan Controls Corporation assumes no responsibility for customers applications or product design. The information and data contained herein is the sole and exclusive property of Artisan Controls Corporation. Any duplication, misuse, or conversion of this information without the express written consent of Artisan Controls Corporation is illegal and will result in damages including court costs and attorney fees being assessed against the party misusing this property.

Tel: 973-598-9400 • Fax: 973-598-9410 • Toll Free: 800-457-4950
Artisan Controls Corporation, 111 Canfield Ave, Bldg B15-18, Randolph, New Jersey 07869, USA



Solid State Timers and Controllers

Specifications

- Operating Voltage:** 18V-50V, 30V-100V, 100V-288V, & 19V-288V AC 50/60 Hz or DC, (See *Ordering Information*).
- Timing Mode:** Delay-On-Make, External load energizes after preset timing period as set by the 10 DIP switches.
- Timing Range:** 0.1 - 102.4 seconds & 2 - 2048 seconds (See *Ordering Information*).
- Timing Adjustment:** 0.1 second for the 438USA-1, -2, & -3, 2 seconds for the 438USA-4
- Programmable Timing Tolerance:** ±10% or 100 milliseconds, whichever is greater.
- Timing Variation:** ±15% worst case at any combination of operating voltage and temperature. ±1% nominal.
- Repeatability Of Timing Period:** 50 milliseconds if output is ON, 200 milliseconds during a timing cycle while output is OFF.
- Recycle Time:** 10 milliamperes to 1 ampere inductive with inrush current to 25 amperes for 8 milliseconds.
- Output Rating:** 4 volts maximum.
- Output Voltage Drop in "ON" State:** 0.5 mA @ 18V, 1.8 mA @ 50V, 4.8 mA @ 100V, 13 mA @ 288V.
- Leakage Current in "OFF" State:** Maximum transient voltage protection is 6000 volts as delivered through a source resistance of 30 ohms with a maximum duration of 8.3 milliseconds.
- Transient Protection:** -20°C to +85°C
- Operating Temperature:** 95% condensing
- Humidity:** Two (2) .25 Faston type.
- Terminations:** UL File E47858, Appliance Controls - Component ATNZ2 (US) & ATNZ8 (Can), Auxiliary Devices - Component NKCR2 (US) & NKCR8 (Can).
- Agency Certifications:** September 25, 2006

Data Sheet Revision Date:

Example of Setting the DIP Switches For A Delay of 60 Seconds

To illustrate the setting of the DIP switches, assume that a 60 second delay period is to be programmed by the 10 DIP switches for the model 438USA-1. In order to achieve the 60 seconds we must add an additional 59.9 seconds to the initial minimum delay of 0.1 second. Begin with all DIP switches closed. Now open switch #10 and subtract its value of 51.2 seconds from the 59.9, the result is 8.7. Move down to the next lower DIP switch and repeat the process. However, switch #9 (25.6 seconds) is greater than the 8.7 seconds, so return switch #9 to the closed position and move down to the next lower switch #8. Switch #8 (12.8 seconds) is still greater than the 8.7 seconds, so return switch #8 to the closed position and move down to the next lower switch #7. Switch #7 (6.4 seconds) is now subtracted from the 8.7 resulting in 2.3 seconds remaining. Leave switch #7 in the open position and move down to switch #6. Switch #6 (3.2 seconds) is again greater than the 2.3 seconds, so return switch #6 to the closed position and move down to the next lower switch #5. Switch #5 (1.6 seconds) is now subtracted from the 2.3 resulting in 0.7 seconds remaining. Leave switch #5 in the open position and move down to switch #4. Switch #4 (0.8 seconds) is again greater than the 0.7 seconds, so return switch #4 to the closed position and move down to the next lower switch #3. Continue this procedure with switches #3, #2, and #1, which will all be moved to the open position. This technique will work for any time from 0.1 to 102.4 seconds.

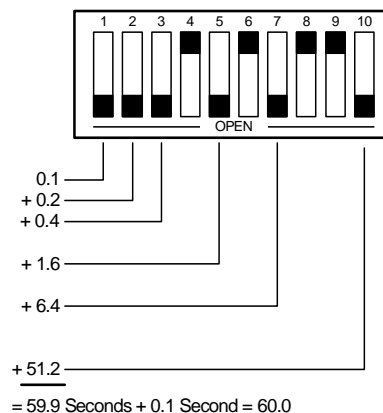

Ordering Information

Part Number	Time Range	Operating Voltage
438USA-1	0.1 - 102.4 seconds	18V - 50V AC or DC
438USA-2	0.1 - 102.4 seconds	30V - 100V AC or DC
438USA-3	0.1 - 102.4 seconds	100V - 288V AC or DC
438USA-4	2 - 2048 seconds	19V - 288V AC or DC

VISIT OUR WEB SITE AT: www.artisancontrols.com

Notice: Artisan Controls Corporation assumes no responsibility for customers applications or product design. The information and data contained herein is the sole and exclusive property of Artisan Controls Corporation. Any duplication, misuse, or conversion of this information without the express written consent of Artisan Controls Corporation is illegal and will result in damages including court costs and attorney fees being assessed against the party misusing this property.

Tel: 973-598-9400 • Fax: 973-598-9410 • Toll Free: 800-457-4950
Artisan Controls Corporation, 111 Canfield Ave, Bldg B15-18, Randolph, New Jersey 07869, USA