

Features

- 20, 50, 100, 250 and 500 mV full-scale input ranges
- 4 or 6-wire hookup to avoid power supply and lead resistance effects
- Digital span adjust from 0 to $\pm 99,999$, zero adjust from $-99,999$ to $+99,999$
- RS232 or RS485 serial data output, half or full duplex, isolated
- Modbus RTU, Modbus ASCII or Laurel ASCII protocol
- 4-20 mA or 0-10V transmitter output, jumper selectable, isolated
- Easy setup using PC-based Instrument Setup Software
- DIN rail mount housing only 22.5 mm wide
- Detachable screw clamp connectors
- 5V, 10V or 24V dc transducer excitation output, isolated
- Dual solid state relay for alarm or control, isolated
- Universal AC power, 85-264 Vac, or low voltage power, 10-48 Vdc or 12-32 Vac
- Custom curve linearization and rate from successive readings (optional)

Description

The Laureate load cell or microvolt input transmitter is designed for use with load cells, strain gauges and microvolt input signals where exceptional sensitivity and stability are required. A most sensitive full-scale input range ± 20 mV can be scaled internally to $\pm 99,999$ counts. The selected input range for the full 0-20 mA output span can be as wide as $\pm 99,999$ counts or as narrow as 150 counts, limited only by considerations of electrical noise and time constants of the programmable moving average digital filter.

A built-in, isolated, 10V, 120 mA excitation supply can power up to four 350-ohm load cells in parallel. Load cell connection can be via 4 or 6 wires. With 4-wire load connection, the transmitter operates in a ratiometric mode to eliminate errors due to power supply variations. With 6-wire load connection, it also compensates for lead resistance, allowing long cable runs.

Fast read rate at up to 50 or 60 conversions per second while integrating the signal over a full power line cycle is provided by Concurrent Slope (Pat 5,262,780) analog-to-digital conversion. High read rate is ideal for peak or valley capture and for real-time computer interface and control.

Digital signal filtering modes are selectable for stable readings in electrically noisy environments.

- An unfiltered selection provides true peak and valley readings and aids in control applications.
- A batch average filter selection averages each 16 conversions for an update every 1/4 sec.
- An adaptive moving average filter selection provides a choice of 8 time constants from 80 ms to 9.6 s. When a significant change in signal level occurs, the filter adapts by briefly switching to the shortest time to follow the change, then reverts back to its selected time constant. An Auto setting selects the time constant selection based on signal noise.

Standard features of Laureate transmitters include:

- **4-20 mA, 0-20 mA or 0-10V analog transmitter output**, isolated, jumper-selectable and user scalable. All selections provide 16-bit (0.0015%) resolution of output span and 0.02% output accuracy of a reading from $-99,999$ to $+99,999$ counts that is also transmitted digitally. Output isolation from signal and power grounds eliminates potential ground loop problems. The supply can drive 20 mA into a 500Ω (or lower) load for 10V compliance, or 10V into a $5k\Omega$ m (or higher) load for 2 mA compliance.
- **Serial communications output**, isolated. User selectable RS232 or RS485, half or full duplex. Three protocols are user selectable: Modbus RTU, Modbus ASCII, or Laurel ASCII. Modbus operation is fully compliant with Modbus Over Serial Line Specification V1.0 (2002). The Laurel ASCII protocol allows up to 31 Laureate devices to be addressed on the same RS485 data line. It is simpler than the Modbus protocol and is recommended when all devices are Laureates. It also allows use of Laurel Datalogging Software.
- **Dual solid state relays, isolated**. Available for local alarm or control. Rated 120 mA at 130 Vac or 170 Vdc.
- **Transducer excitation output**, isolated. User selectable 5V@100 mA, 10V@120 mA or 24V@50 mA.
- **Universal 85-264 Vac power**. Low-voltage 10-48 Vdc or 12-32 Vac power is optional.

Easy Transmitter programming is via Laurel's Instrument Setup Software, which runs on a PC under MS Windows. This software can be downloaded from this website at no charge. The required transmitter-to-PC interface cable is available from Laurel (P/N CBL04).

Specifications

Analog Input	Range	Input Ohms	Input Ohms
Load Cell Input	±20.000 mV ±50.0000 mV ±100.00 mV ±250.00 mV ±500.00 mV	-99,999 to +99,999 zero adjust. 0 to ±99,999 span adjust.	1 GΩ
Microvolt Input	±20.000 mV ±50.0000 mV ±100.00 mV ±250.00 mV ±500.00 mV	1 μV 2.5 μV 5.0 μV 12.5 μV 25 μV	1 GΩ
Input Resolution Input Accuracy Update Rate, Max Max applied voltage	16 bits (65,536 steps) ±0.01% of full scale ± 2 counts 50/sec at 50 Hz, 60/sec at 60 Hz 100 V		
Analog Output (standard)			
Output Levels Compliance, 4-20 mA Compliance, 0-10V Output Resolution Output Accuracy Output Isolation Step response time	4-20 mA, 0-20 mA, 0-10 Vdc (jumper selectable) 10V (0-500Ω load) 2 mA (5 kΩ load or higher) 16 bits (65,536 steps) 0.02% of output span plus conversion accuracy 250V rms working, 2.3 kV rms per 1 minute test 50 ms		
Serial Communications Output (standard)			
Signal Types Data Rates Output Isolation Serial Protocols Modbus Modes Modbus Compliance Digital Addressing	RS232 or RS485 (half or full duplex) 300, 600, 1200, 2400, 4800, 9600, 19200 baud 250V rms working, 2.3 kV rms per 1 min test Modbus RTU, Modbus ASCII, Laurel ASCII RTU or ASCII Modbus over Serial Line Specification V1.0 (2002) 247 Modbus addresses. Up to 32 devices on an RS485 line w/o a repeater.		
Dual Relay Output (standard)			
Relay Type Load Rating	Two solid state relays, SPST, normally open, Form A 120 mA at 140 Vac or 180 Vdc		
Transducer Excitation Output (standard)			
Output Levels Output Isolation	5V@100 mA, 10 @120 mA, 24V@50 mA (jumper selectable) 50V from signal ground		
Power Input			
Standard Power Low Power Option Power Frequency Power Isolation Power Consumption	85-264 Vac or 90-300 Vdc (DC operation not ETL approved) 10-48 Vdc or 12-32 Vac DC or 47-63 Hz 250V rms working, 2.3 kV rms per 1 min test 2Watts		
Mechanical			
Dimensions Mounting Electrical Connections	129 x 104 x 22.5 mm case 35 mm rail per DIN EN 50022 Plug-in screw-clamp connectors		
Environmental			
Operating Temperature Storage Temperature Relative Humidity Cooling Required	0°C to 55°C -40°C to 85°C 95% at 40°C, non-condensing Mount transmitters with ventilation holes at top and bottom. Leave 6 mm (1/4") between transmitters, or force air with a fan.		

Pinout

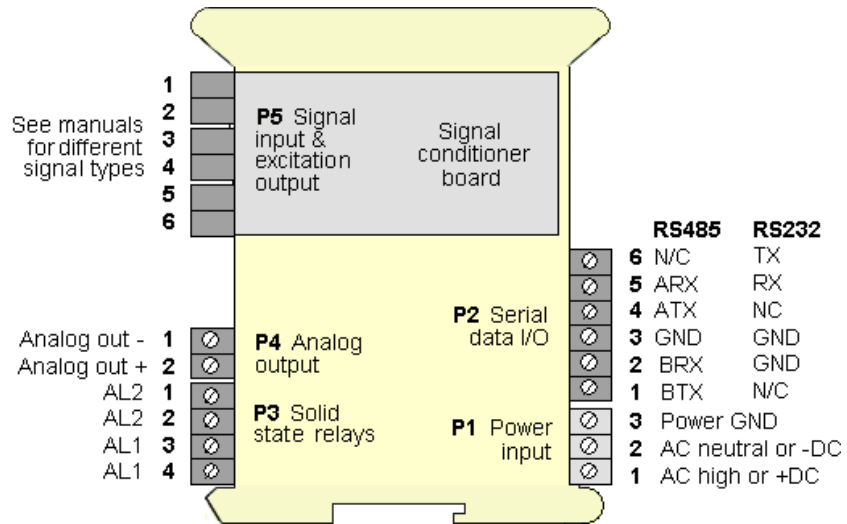

Mechanical

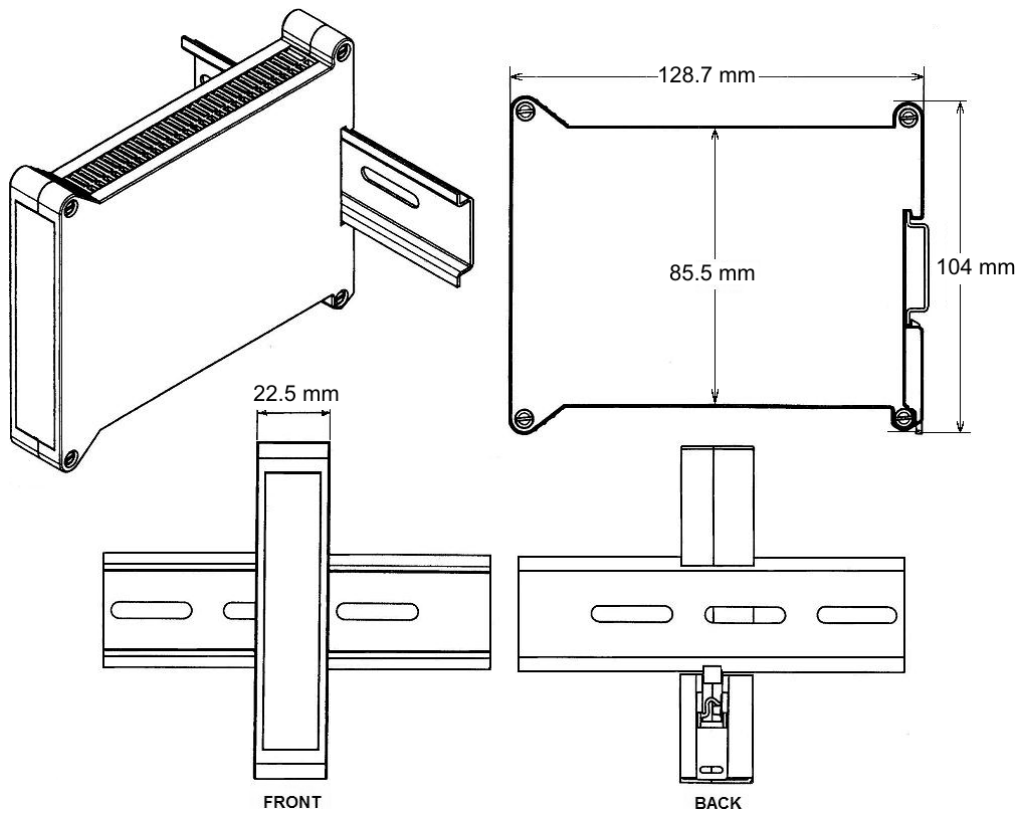

Load Cell Transmitter Connections

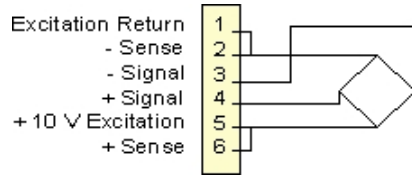

In 4-wire connection, the excitation and sense lines are tied together. The transmitter can make ratiometric corrections for supply voltage variations, but does not compensate for variations in lead resistance. This connection is often used with short cable runs.

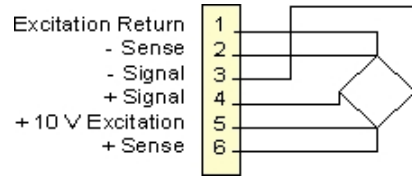

In 6-wire connection, the sense lines are separate from the excitation lines, thereby eliminating effects due to variations in lead resistance. This allows long cable runs in outdoor environments with temperature extremes.

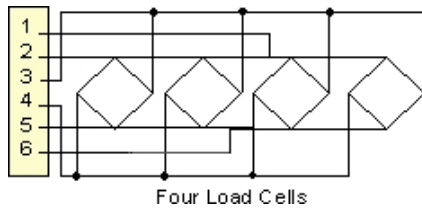

For large scales, up to four 350 ohm load cells in parallel can be powered by a single Laureate transmitter at 10V, 120 mA excitation. The excitation and sense points of the four bridges are connected in parallel through a summing box.

Ordering Guide

Create a model a model number in this format: **LT20WM, CBL04**

Transmitter Type	LT Laureate Transmitter
Main Board	2 Standard Main Board 4 Extended Main Board Note: Extended allows custom curve linearization and rate from successive readings.
Power	0 85-264 Vac 1 12-32 Vac or 10-48 Vdc
Signal Input	Load Cell (4- or 6-wire ratio) WM Field scalable. Default scaling is 0-20 mV in = 4-20 mA out WM1 Custom Scaling. Specify min input, min output; max input, max output
Accessories	CBL04 RS-232 cable, LTA to computer or USB adapter CBL02 USB to RS-232 cable adapter