

# Connectors

RJ45 & USB high speed connector system



# Contents

03	Company Profile
04	About TT Electronics
06	RJ56 & USB introduction
	AB05 R6
07	<i>Profile &amp; technical information</i>
08	<i>Part number explanation</i>
09	<i>Insert orientations</i>
10	<i>AB05 R6 type 20 / type 31 / type 60</i>
11	<i>Protective cap (fixed and free)</i>
12	<i>Panel cut out</i>
	ABAC R6
13	<i>Profile &amp; technical information</i>
14	<i>Part number explanation</i>
15	<i>Insert orientations</i>
16	<i>ABAC R6 type 20 / type 24 / type 26</i>
17	<i>Protective cap (fixed)</i>
18	<i>Protective cap (free)</i>
18	<i>Panel cut out</i>
	ABAC R6A
19	<i>Profile &amp; technical information</i>
20	<i>Part number explanation</i>
22	<i>ABAC R6A type 20 / type 24 / type 26</i>
	ABAC UA
23	<i>Profile &amp; technical information</i>
24	<i>Part number explanation</i>
25	<i>Insert orientations</i>
26	<i>ABAC UA type 20 / type 24 / type 26</i>
27	<i>Protective cap (fixed)</i>
28	<i>Protective cap (free)</i>
29	<i>Panel cut out</i>
30	Wiring and assembly instructions
32	FAQ
34	Safety information
35	TT electronics and the environment
36	Land Based / Rail Vehicles brochure links
37	Global Sales Offices



# Company Profile

There are TT electronics products in every single military vehicle deployed in conflict zones across the globe.

TT electronics plc is an international electronics company that has been supplying innovative high reliability components to the military and defence markets for more than 30 years. The knowledge and experience gained in that time has been brought together in a global team of designers and applications engineers dedicated to supporting the unique requirements of modern military applications. Our industry experience and agile approach to business has given us a pre-eminent position in the supply of connectors and other components to land-based military vehicles.

As a major plc listed on the London stock exchange, TT electronics plc has the financial resources to continually invest in up-to-the-minute manufacturing facilities to address our customer's needs and provide them with the correct solution.

With design and manufacturing plants in Europe and the USA, we are able to fulfil the Urgent Operational Requirements (UORs) of defence forces globally with industrial and mil spec compliant connectors and assemblies at exceptionally short notice.

In the harsh and unforgiving environment of the modern battlefield, it is essential that every single component is fit for purpose. Working closely on site with our OEM and ODM customers has given our engineering team a deep understanding of the changing market trends and requirements of land based military vehicles, enabling them to engineer the best possible component solution.



# About TT electronics plc

TT electronics plc is a global electronics company. Within its electronic components group are multiple facilities for design and manufacture of interconnection systems with engineering teams providing custom solutions.

## Military land based vehicles

- Tracked vehicle
- Armoured personnel carriers
- Land Rover
- Unmanned vehicles
- Security services

Electrical systems in the modern military vehicle need to provide the user with a ruggedised reliable solution to the interconnection issues encountered in a battlefield theatre environment. With high reliability being taken as a given we are in the position to offer solutions to brave the most demanding of applications.



## Rotary wing aircraft

- Military helicopters
- Search and Rescue
- Commercial helicopters

Vibration and salt spray are just two of the hazards facing military aircraft. We have developed a range of screening products that allow the termination of multiple screens in just such environments without degradation to interconnection systems. Design and manufacture of complex cable harnesses form part of our core strengths. We are actively involved with all systems within helicopter operations including UOR activities system upgrades and role fits.



## Military fixed wing aircraft

Jet fighters  
Propeller technology  
Reconnaissance  
Mission control suites

The requirement for electrical protection on military platforms becomes even more critical as both the natural effects of lightning and the effect of warfare can play havoc with electrical systems in the air and on the ground.

We provide cost effective electrical interface systems designed to withstand the effects of EMC, EMI, EMP and HIRF along with the harshest of environmental conditions.



## Missile and defensive suites

Defensive aids suites  
Test equipment solutions  
Radar equipment interconnects

As the need grows for smaller systems we design lighter, more compact interconnection systems featuring miniaturisation of connector products and lightweight wiring solutions. Screening remains a high priority and a full range of connector accessories for all styles of connector form part of our portfolio to ensure design is not compromised in any way



## Civil aircraft

Landing gear  
Flight guidance systems  
Engine management

The civil aircraft market demands reliable manufacturing processes. We produce critical systems designed to ensure our solutions are in line with those requirements. Cost efficient, light-weight reliable solutions are an integral part of any design specification.

We have a market leading technology in composite systems, enabling your designers to enhance your product offering to your customer.



## Naval systems

Radar systems  
Submarine communications  
Panel assemblies

The issues facing naval applications bring a whole new set of problems to the design of interconnection systems. We offer screened cable and conduit systems approved for "above deck full threat EMP protection". The ability to manufacture interconnection panels and a component product range offering salt spray protection, ensures environmental issues are catered for during the design process



# High Performance Interconnect for Cat 5e, Cat 6 & Cat 6a and USB 2.0 in Harsh Environments

## introduction

**The high speed RJ45 & USB connector systems** incorporate an ABAC (MIL-DTL-38999 series III) or AB05 (MIL-DTL-26482) derived metal shell with full 360 degree EMC and mechanical protection, and has been designed to meet the requirements of high speed data connections where reliability through environmental sealing and enhanced mechanical protection are required.

## Performance

- Cat 5e per ISO/IEC 11801
  - Cat 6 1Gb with enhanced grounding option
  - Cat 6a 10Gb with enhanced grounding option
  - USB High Speed (2.0) 480Mbit/sec
  - Fully sealed to IP68 for fluid and dust laden environments
  - High levels of shock, vibration and mechanical impact protection
  - Fully enclosed connector shells for superior mechanical strength
  - Positive cordset retention >200N axial force
- 

# AB05 R6

## Bayonet Connector for up to 1Gb/sec transmissions

### product profile

The **AB05 R6** provides Ethernet Cat 5e or Cat 6 connections for up to 1Gb 1000 BaseT networks in harsh environments. The AB05 R6 connectors are supplied with a high performance RJ connector which is matched to the AB05 housing, guarantee mechanical, environmental and electrical performance. The coupled connector will be fully protected from shocks, dust and fluids.

### technical information

#### Features

- Bayonet coupling with audible snap and visual indicator
- Robust metallic shells based on MIL-DTL-26482
- 200N retention of the RJ45 in the plug
- 500 min mating cycles
- IP68 sealing against fluids and dust
- Shock and vibration resistant
- Multiple insert orientations
- Fully intermateable with Amphenol RJF

#### Applications

Ideal for all industrial applications, including:

- Robotics
- Industrial Process Control
- CNC machines
- Oil & gas
- Motion control
- Advanced motorway and highway indicators and signage systems
- Mass transit and traction



#### Data transmission

- 10 BASE-T, 100 BASE-TX, and 1000 BASE-T networks
- Cat 5e per TIA/EIA 568B and Class D per ISO/IEC11801
- Cat 6

#### Environmental protection

- Ingress protection: BS EN 60529:1991 IP6x – Dust ingress for 8 hours. IPx8 – Water immersion to 1m for 2 hours
- Vibration: BS EN 60068-2-6:1996 Test Fc. 10 – 11Hz @ 45mm Peak to Peak, 11 – 500Hz @ 11g (Peak), Sweep Rate: 1 octave/minute, Duration: 1 hour/axis
- Shock: BS EN 60068-2-27:2009 Test Ea. 50g for 1ms half sine shock, 3 shocks in each of six directions
- Temperature: BS EN 60068-2-1:1993 Test Ab and BS EN 60068-2-2:1993 Test Bb. Operational for 2 hours at -40°C followed by 2 hours at +120°C
- Thermal shock: BS EN 60068-2-14:1999 Test Na 10 cycles from -40°C to +100°C, with a dwell time of two hours at each extreme and rate of change 8 seconds

**Note: The company reserves the right and may change or vary specification without prior written notice.**

# AB05 R6

## part number explanations

Product range	AB05	20	##	R6	S	#	#
Shell style:	20 : Wall mounting receptacle with accessory thread 32 : Jam nut mounting receptacle with accessory thread 60 : Cable mounted plug with integral cable seal						
Plating:	F : Electroless nickel Q : Zinc cobalt (olive drab) W : Cadmium (olive drab) S : Nickel over stainless steel BZ : Aluminium bronze K : Stainless steel QB : Black zinc cobalt						
Insert style:	R6: 8P8C (RJ45) Cat 6						
Gender:	P: Plug S: Socket						
Key/keyway polarization:	N/A/B/C/D/E						
Insert orientation:	W/X/Y/Z						
Accessory style:	00: No accessory						
Cable options	0: No cable 1: Terminated at connector end only						
Cable length	L0: No cable L1: 1 meter L2: 2 meters L3: 3 meters L5: 5 meters LC: Custom length - use MOD Code for length specification						
MOD Code	Omit when no MOD is required 21: High integrity grounding (shell style 26) 22: Feed-through connector isolated from outer shell 23: 'BT' termination style						



# AB05 R6

insert orientations (receptacles shown)

##

#

##

###

insert orientation W

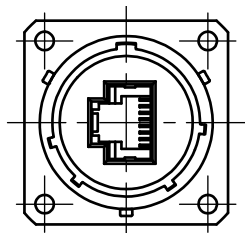

insert orientation X

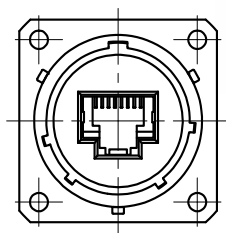

insert orientation Y

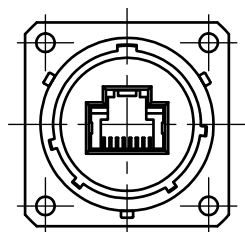

insert orientation Z

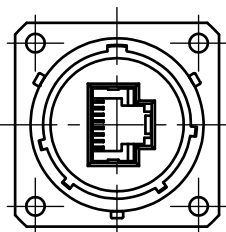

## AB05 R6 type 20

Square flange receptacle for Cat 5e and Cat 6, up to 1Gb/sec

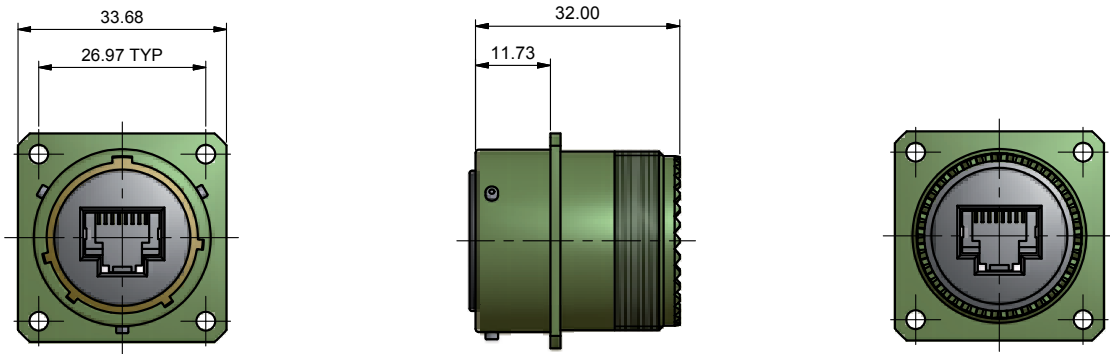

## AB05 R6 type 32

Jam nut receptacle for Cat 5e and Cat 6

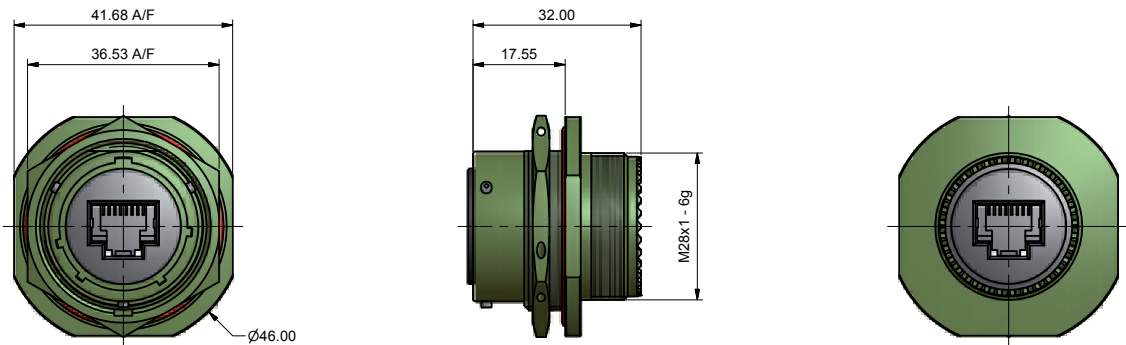

## AB05 R6 type 60

Cable plug for Cat 5e and Cat 6

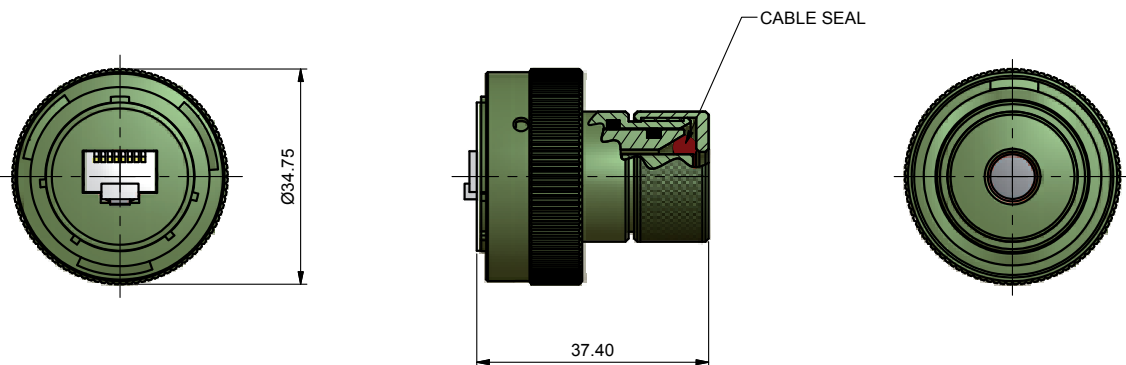

# AB05

## Protective cap (fixed)

part number:  
 AB05 0065 18 ## for square flange  
 AB05 0066 18 ## for jam nut

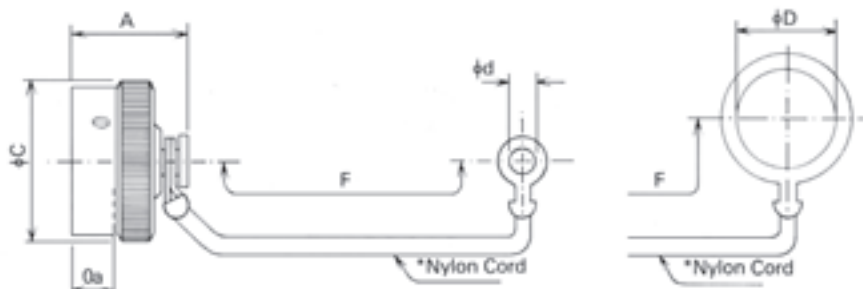

Shell Size	A max	C Ø max	d Ø min	D Ø min	F approx	Oa min	MASS max G
18	21.10	35.60	3.05	32.0	89.0	7.30	20

## Protective cap (free)

part number: AB05 0070 18 ##

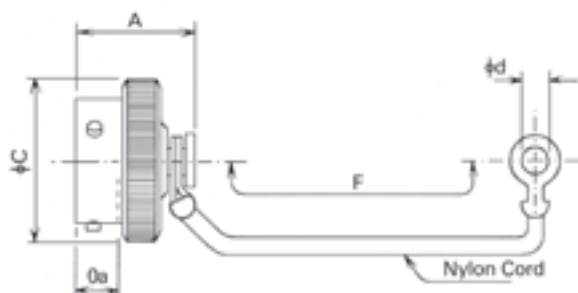

Shell Size	A max	C Ø max	d Ø min	F approx	Oa min	MASS max G
18	20.10	35.60	3.05	89.0	7.30	17

Note

- ## = Leave blank for cadmium
- 59 = Zinc Cobalt Olive drab
- 100 = Zinc Cobalt Black
- 118 = Electroless Nickel
- 216 = Stainless Steel

## AB05 Panel cut out Style: Square flange

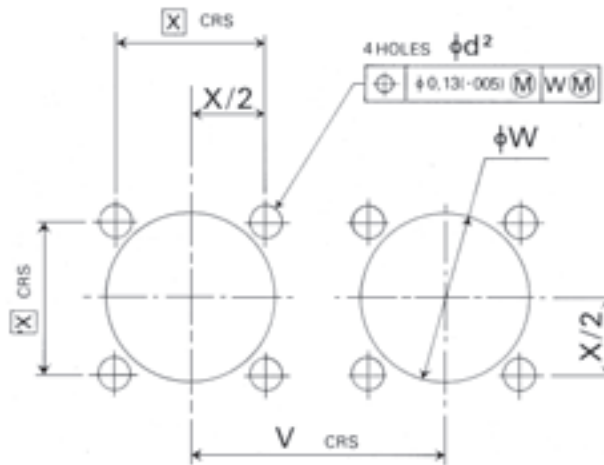

- \*P Max. panel thickness
- P Min. clearance distance for mating connector  
Size 8 to 18-2,0 (0,08)
- \*P May be increased if 'W' is enlarged to clear accessory

Shell Size	d <sup>2</sup> Ø min.	V min.	W Ø	X
18	3.25	40.90	31.45	26.97

## AB05 Panel cut out Style: Jam nut

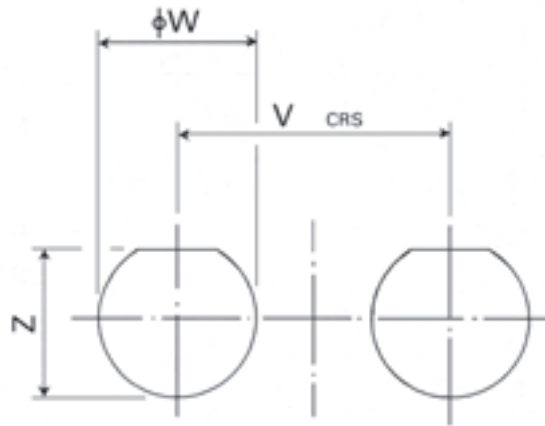

Shell Size	V min.	W Ø	Z
18	37.10	43.0	32.00

# ABAC R6

## 38999 III Connector for up to 1Gb/sec transmissions

### product profile

The **ABAC R6** connector provides a harsh environment interconnect solution for Cat 5e or Cat 6, 10 BASE-T, 100 BASE-TX, and 1000 BASE-T networks. The ABAC R6 connectors are supplied with a high performance RJ connector which is matched to the ABAC housing, to guarantee all mechanical, environmental, and electrical performance. The coupled connector will be fully protected from any shock, dust and fluids. The RJ connector is grounded to the outer connector shell and to the panel to provide outstanding EMI/RFI screening performance.

### technical information

#### Features

- Robust metallic shells based on MIL-DTL-38999 III
- Three start threaded coupling with anti vibration ratchet and visual indicator
- High performance grounding system between Plug and Receptacles
- 200N retention of the RJ45 in the plug
- 500 min mating cycles
- IP68 sealing against fluids and dust
- Shock and vibration resistant
- Multiple insert orientations
- Intermateable and interchangeable with other manufacturers including Amphenol RJFTV

#### Applications

- Battlefield communication
- Radar
- Fighting vehicles
- Missile systems
- Surveillance systems
- Naval applications
- Avionics test equipment

#### Data transmission

- 10 BASE-T, 100 BASE-TX, and 1000 BASE-T networks
- Cat 5e per TIA/EIA 568B and ClassD per ISO/IEC11801
- Cat 6

#### Environmental protection

- Ingress protection: BS EN 60529:1991 IP6x – Dust ingress for 8 hours. IPx8 – Water immersion to 1m for 2 hours
- Vibration: BS EN 60068-2-6:1996 Test Fc. 10 – 11Hz @ 45mm Peak to Peak, 11 – 500Hz @ 11g (Peak), Sweep Rate: 1 octave/minute, Duration: 1 hour/axis
- Shock: BS EN 60068-2-27:2009 Test Ea. 50g for 1ms half sine shock, 3 shocks in each of six directions
- Temperature: BS EN 60068-2-1:1993 Test Ab and BS EN 60068-2-2:1993 Test Bb. Operational for 2 hours at -40°C followed by 2 hours at +120°C
- Thermal shock: BS EN 60068-2-14:1999 Test Na 10 cycles from -40°C to +100°C, with a dwell time of two hours at each extreme and rate of change 8 seconds

**Note:** The company reserves the right and may change or vary specification without prior written notice.



# ABAC R6

## part number explanations

Product range	ABAC	20	##	R6	S	#	#
Shell style:	20 : Wall mounting receptacle with accessory thread						
	24 : Jam nut mounting receptacle with accessory thread						
	26 : Cable mounted plug with integral cable seal						
Plating:	F : Electroless nickel						
	Q : Zinc cobalt (olive drab)						
	W : Cadmium (olive drab)						
	S : Nickel over stainless steel						
	BZ : Aluminium bronze						
	K : Stainless steel						
	QB: Black zinc cobalt						
Insert style:	R6: 8P8C (RJ45) Cat 6						
Gender:	P: Plug						
	S: Socket						
Key/keyway polarization:	N/A/B/C/D/E						
Insert orientation:	W/X/Y/Z						
Accessory style:	00: No accessory						
Cable options	0: No cable						
	1: Terminated at connector end only						
Cable length	L0: No cable						
	L1: 1 meter						
	L2: 2 meters						
	L3: 3 meters						
	L5: 5 meters						
	LC: Custom length - use MOD Code for length specification						
MOD Code	Omit when no MOD is required						
	21: High integrity grounding (shell style 26)						
	22: Feed-through connector isolated from outer shell						
	23: 'BT' termination style						

# ABAC R6

insert orientations (receptacles shown)

## # ## ###

insert orientation W

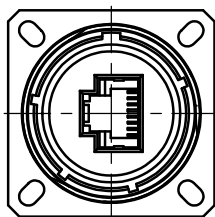

insert orientation X

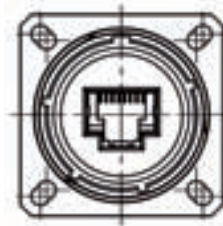

insert orientation Y

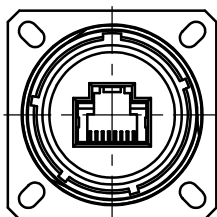

insert orientation Z

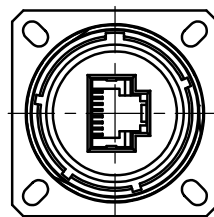

## ABAC R6 type 20

Square flange receptacle for Cat 5e and Cat 6

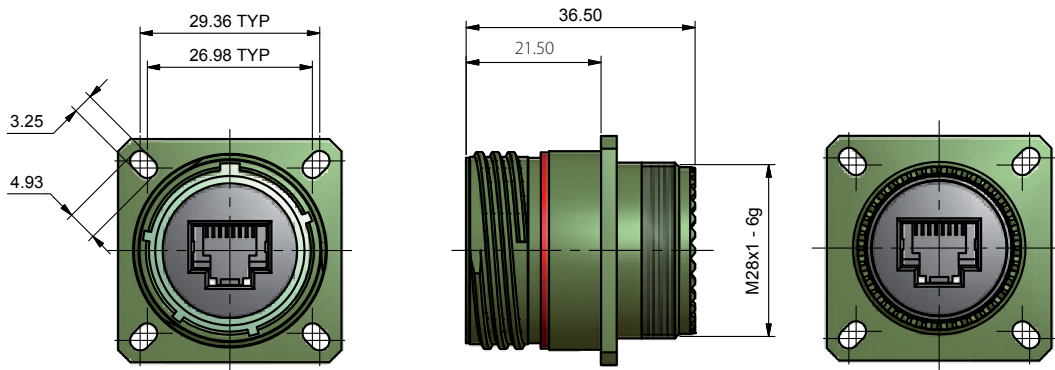

## ABAC R6 type 24

Jam nut receptacle for Cat 5e and Cat 6

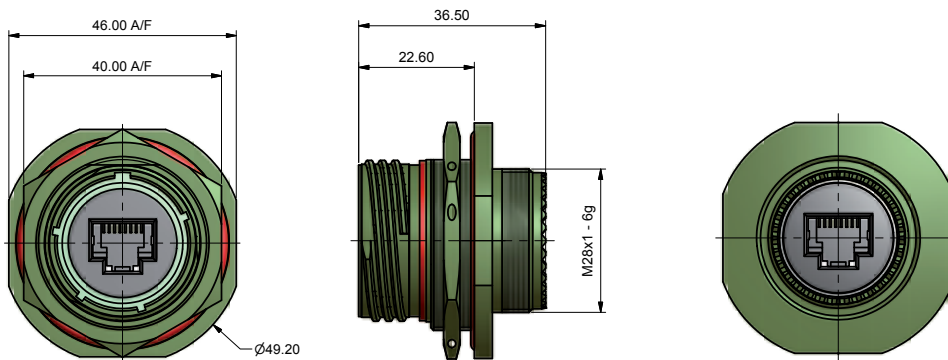

## ABAC R6 type 26

Cable plug for Cat 5e and Cat 6

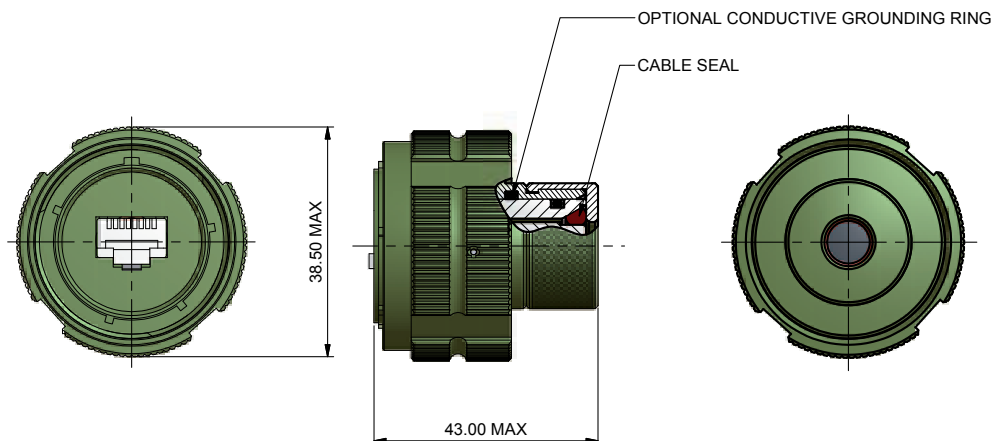



## ABAC Protective cap (fixed)

Style: ABAC/33#19R

part number: ABAC/33#19R

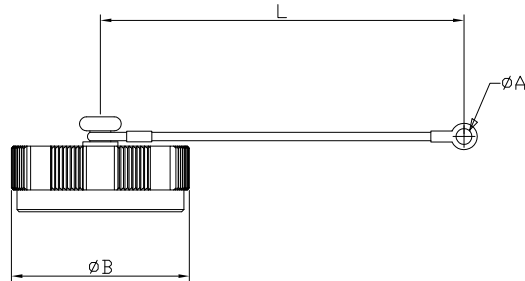

Shell Size	AB Part No.	AØ min	B Ø max	L +12.7 - 6.35	38999 Part No.
19	ABAC/33#19R	3.90	38.10	127	D38999/33#19R

## ABAC Protective cap (fixed)

Style: ABAC/33#19N

part number: ABAC/33#19N

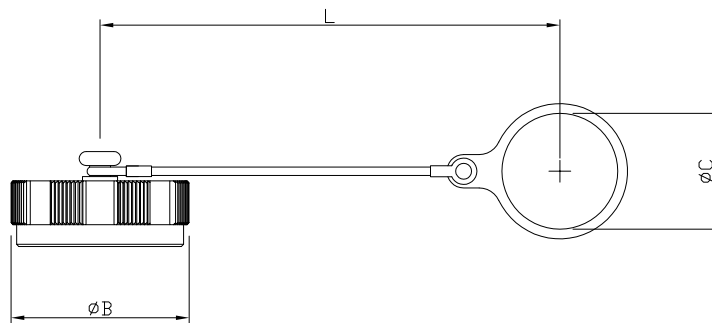

Shell Size	AB Part No.	CØ min	B Ø max	L +12.7 - 6.35	38999 Part No.
19	ABAC/33#19N	36.27	38.10	127	D38999/33#19N

# ABAC Protective cap (free)

Style: ABAC/32#19R

Part Number: ABAC/32#19R

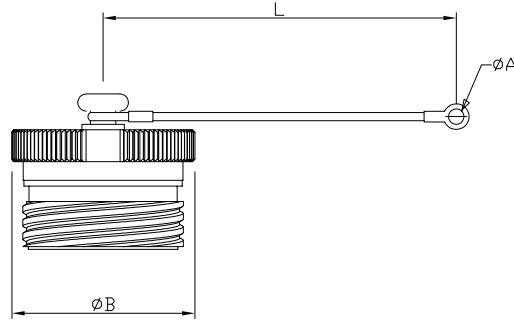

Shell Size	AB Part No.	AØ min	B Ø max	L +12.7 - 6.35	38999 Part No.
19	ABAC/32#19R	3.90	38.10	127	D38999/32#19R

# ABAC Protective cap (free)

Style: ABAC/32#19N

Part Number: ABAC/32#19N

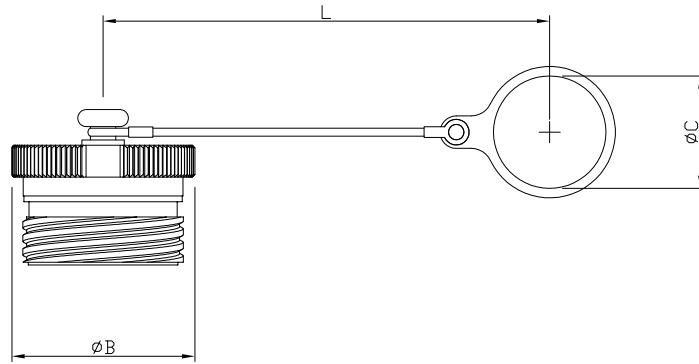

Shell Size	AB Part No.	CØ min	B Ø max	L +12.7 - 6.35	38999 Part No.
19	ABAC/32#19N	36.27	38.10	127	D38999/32#19N

# ABAC Panel cut out

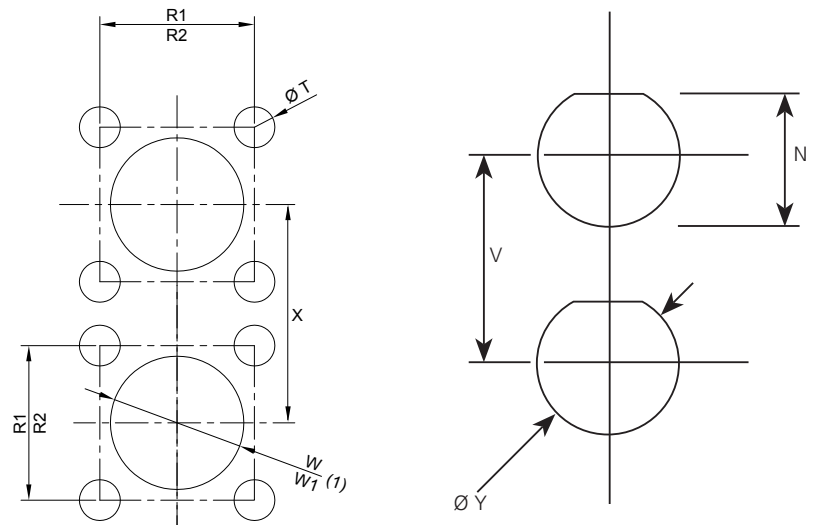

Shell Size	N-0.25	R1 rear mount	R2 front mount	T Ø +/- 0.13	V min	W min rear mount	W1 min front mount	X min -0.25	ø Y
19	33.91	29.36	26.97	3.25	50.40	32.94	28.98	39.24	35.18

# ABAC R6A

## Threaded Connector for up to 10Gb/sec transmissions

### product profile

**ABAC R6A** connectors provide a harsh environment interconnect solution for Ethernet Cat 6a, 10GBASE-T, and achieve data transmission speeds of 10Gb/sec. The ABAC R6A connectors are supplied with a high performance RJ connector which is matched to the ABAC housing, to guarantee all mechanical, environmental, and electrical performance. The coupled connector will be fully protected from any shock, dust and fluids. The RJ connector is grounded to the outer connector shell and to the panel to provide outstanding EMI/RFI screening performance.

### technical information

#### Features

- Robust metallic shells based on MIL-DTL-38999 III
- Three start threaded coupling with anti vibration ratchet and visual indicator
- High performance grounding system between Plug and Receptacles
- 200N retention of the RJ45 in the plug
- 500 min mating cycles
- IP68 sealing against fluids and dust
- Shock and vibration resistant

#### Applications

- Battlefield communication
- Radar
- Fighting vehicles
- Missile systems
- Surveillance systems
- Naval applications

#### Data transmission

- 10 BASE-T, 100 BASE-TX, 1000 BASE-T, 1000 BASE-TX
- Cat 6a

#### Environmental protection

- Ingress protection: BS EN 60529:1991 IP6x – Dust ingress for 8 hours. IPx8 – Water immersion to 1m for 2 hours
- Vibration: BS EN 60068-2-6:1996 Test Fc. 10 – 11Hz @ 45mm Peak to Peak, 11 – 500Hz @ 11g (Peak), Sweep Rate: 1 octave/minute, Duration: 1 hour/axis
- Shock: BS EN 60068-2-27:2009 Test Ea. 50g for 1ms half sine shock, 3 shocks in each of six directions
- Temperature: BS EN 60068-2-1:1993 Test Ab and BS EN 60068-2-2:1993 Test Bb. Operational for 2 hours at -40°C followed by 2 hours at +120°C
- Thermal shock: BS EN 60068-2-14:1999 Test Na 10 cycles from -40°C to +100°C, with a dwell time of two hours at each extreme and rate of change 8 seconds

**Note:** The company reserves the right and may change or vary specification without prior written notice.



# ABAC R6A

## part number explanations

Product range	ABAC	20	##	R6A	S	#	#
Shell style:	20 : Wall mounting receptacle with accessory thread						
	24 : Jam nut mounting receptacle with accessory thread						
	26 : Cable mounted plug with integral cable seal						
Plating:	F : Electroless nickel						
	Q : Zinc cobalt (olive drab)						
	W : Cadmium (olive drab)						
	S : Nickel over stainless steel						
	BZ : Aluminium bronze						
	K : Stainless steel						
	QR: Black zinc cobalt						
Insert style:	R6A: 8P8C (RJ45) CAT. 6a						
Gender:	P: Plug						
	S: Socket						
Key/keyway polarization:	N/A/B/C/D/E						
Insert orientation:	X						
Accessory style:	00: No accessory						
Cable options	0: No cable						
	1: Terminated at connector end only						
Cable length	L0: No cable						
	L1: 1 meter						
	L2: 2 meters						
	L3: 3 meters						
	L5: 5 meters						
	LC: Custom length - use MOD Code for length specification						
MOD Code	Omit when no MOD is required						
	21: High integrity grounding (shell style 26)						
	22: Feed-through connector isolated from outer shell						
	23: 'BT' termination style						

## # ## ###



## ABAC R6A type 20

Square flange receptacle for Cat 5e, Cat 6 or Cat 6a

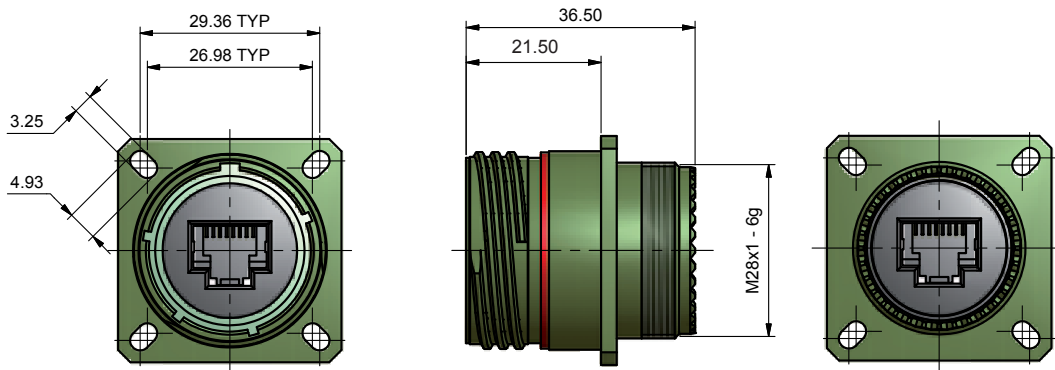

## ABAC R6A type 24

Jam nut receptacle Cat 5e, Cat 6 or Cat 6a

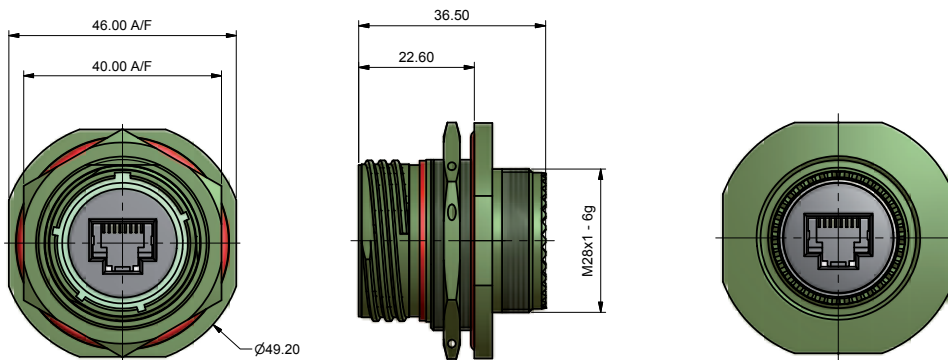

## ABAC R6A type 26

Cable plug Cat 5e, Cat 6 or Cat 6a

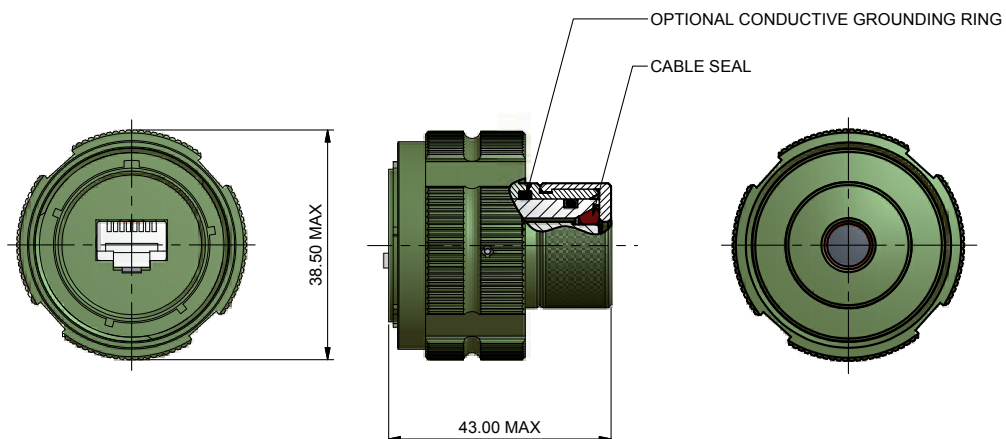

# ABAC UA

## Threaded Connector for USB 1.0 and 2.0 transmissions

### product profile

**ABAC UA** connectors are supplied with a high performance USB 2.0 cordset which is matched to the ABAC housing, to guarantee the highest mechanical, environmental, and electrical performance. The coupled connector will be fully protected from any shock, dust and fluids. The USB connector is grounded to the outer connector shell and to the panel to provide the highest EMI/RFI screening performance.

### technical information

#### Features

- Robust metallic shells based on MIL-DTL-38999 III
- Three start threaded coupling with anti vibration ratchet and visual indicator
- High performance grounding system between Plug and Receptacles
- 200N retention of the USB in the plug
- 500 min mating cycles
- IP68 sealing against fluids and dust
- Shock and vibration resistant
- Multiple insert orientations
- Fully intermateable with Amphenol USBFTV

#### Applications

- Battlefield communication
- Radar
- Fighting vehicles
- Missile systems
- Surveillance systems
- Naval applications

#### Data transmission

- USB specification 2.0
- Data rates up to 480 Mb/s

#### Environmental protection

- Ingress protection: BS EN 60529:1991 IP6x – Dust ingress for 8 hours. IPx8 – Water immersion to 1m for 2 hours
- Vibration: BS EN 60068-2-6:1996 Test Fc. 10 – 11Hz @ 45mm Peak to Peak, 11 – 500Hz @ 11g (Peak), Sweep Rate: 1 octave/minute, Duration: 1 hour/axis
- Shock: BS EN 60068-2-27:2009 Test Ea. 50g for 1ms half sine shock, 3 shocks in each of six directions
- Temperature: BS EN 60068-2-1:1993 Test Ab and BS EN 60068-2-2:1993 Test Bb. Operational for 2 hours at -40°C followed by 2 hours at +120°C
- Thermal shock: BS EN 60068-2-14:1999 Test Na 10 cycles from -40°C to +100°C, with a dwell time of two hours at each extreme and rate of change 8 seconds

**Note: The company reserves the right and may change or vary specification without prior written notice.**



# ABAC UA

## part number explanations

Product range	ABAC	20	##	UA	S	#	#
Shell style:	20 : Wall mounting receptacle with accessory thread						
	24 : Jam nut mounting receptacle with accessory thread						
	26 : Cable mounted plug with integral cable seal						
Plating:	F : Electroless nickel						
	Q : Zinc cobalt (olive drab)						
	W : Cadmium (olive drab)						
	S : Nickel over stainless steel						
	BZ : Aluminium bronze						
	K : Stainless steel						
	QB: Black zinc cobalt						
Insert style:	UA: USB 2.0 type A						
Gender:	P: Plug						
	S: Socket						
Key/keyway polarization:	N/A/B/C/D/E						
Insert orientation:	X/Y/Z						
Accessory style:	00: No accessory						
	0: No cable						
Cable options	1: Terminated at connector end only						
	2: Terminated both ends						
Cable length	L1: 1 meter						
	L2: 2 meters						
	L3: 3 meters						
	L5: 5 meters						
	LC: Custom length - use MOD Code for length specification						
MOD Code	Omit when no MOD is required						
	21: High integrity grounding (shell style 26)						
	22: Feed-through connector isolated from outer shell						
	24: Cable end terminated with USB 2.0 type B plug						



# ABAC UA

insert orientations (receptacles shown)

## # ## ###

insert orientation X

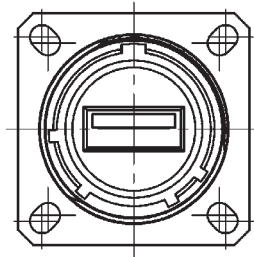

insert orientation Y

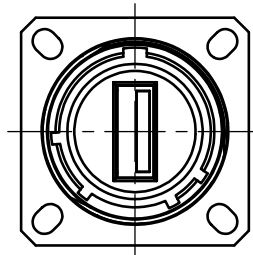

insert orientation Z

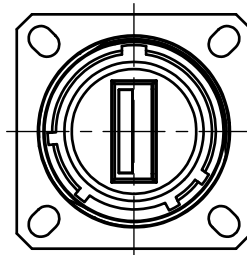

## ABAC UA type 20

Square flange receptacle for USB 2.0

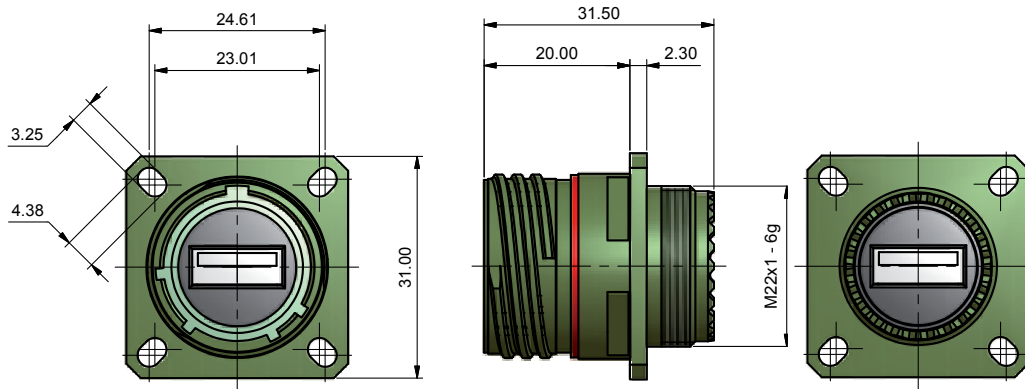

## ABAC UA type 24

Jam nut receptacle for USB 2.0

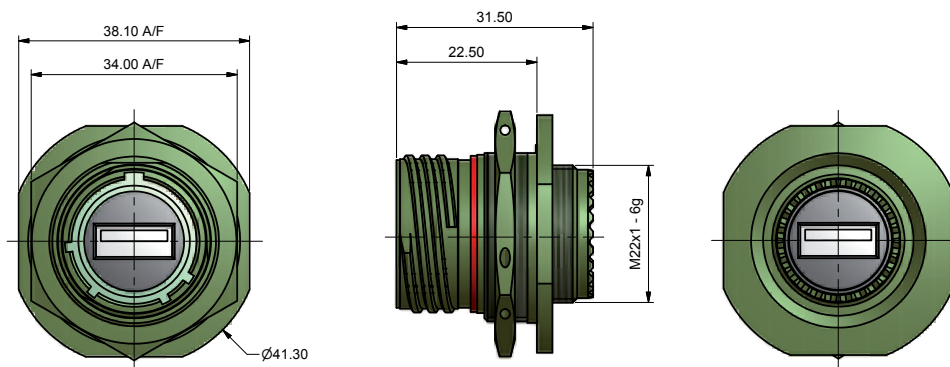

## ABAC UA type 26

Cable plug for USB 2.0

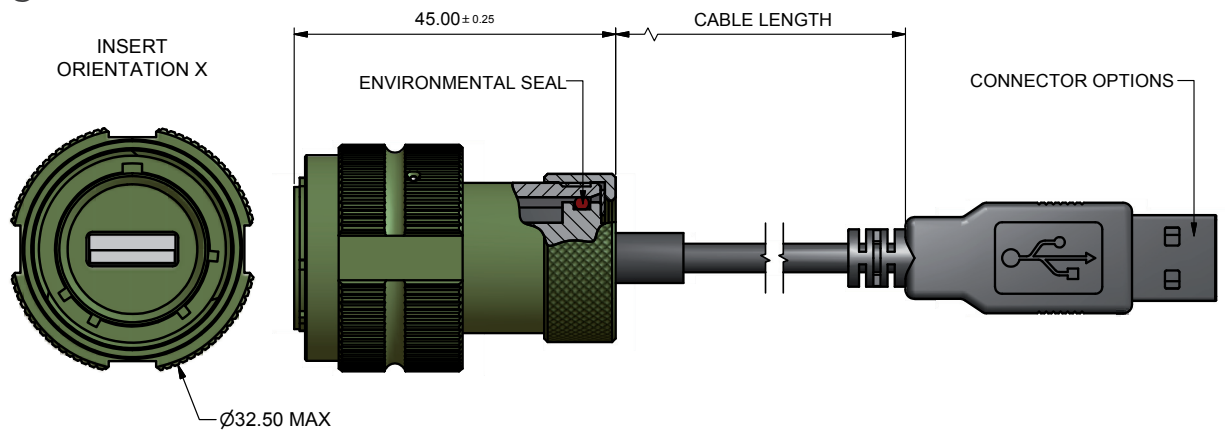

## ABAC Protective cap (fixed)

Style: ABAC/33#15R

part number: ABAC/33#15R

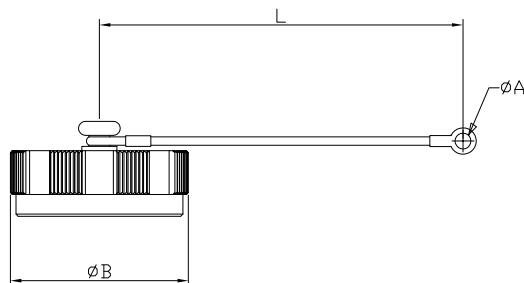

Shell Size	AB Part No.	AØ min	B Ø max	L +12.7 - 6.35	38999 Part No.
15	ABAC/33#15R	3.90	31.75	127	D38999/33#15R

## ABAC Protective cap (fixed)

Style: ABAC/33#15N

part number: ABAC/33#15N

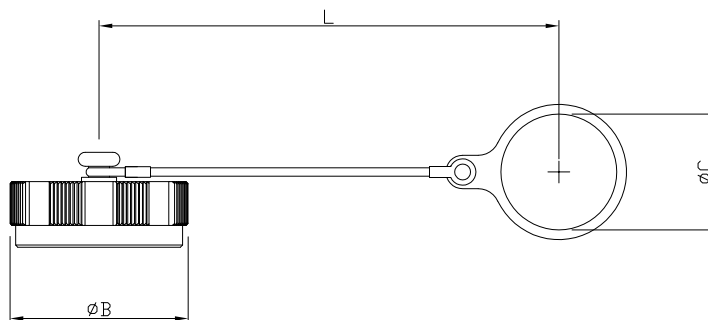

Shell Size	AB Part No.	CØ min	B Ø max	L +12.7 - 6.35	38999 Part No.
15	ABAC/33#15N	29.92	31.75	127	D38999/33#15N

# ABAC Protective cap (free)

## Style: ABAC/32#15R

Part Number: ABAC/32#15R

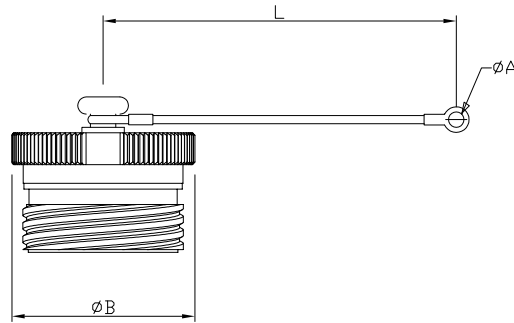

Shell Size	AB Part No.	AØ min	B Ø max	L +12.7 - 6.35	38999 Part No.
15	ABAC/32#15R	3.90	31.75	127	D38999/32#15R

# ABAC Protective cap (free)

## Style: ABAC/32#15N

Part Number: ABAC/32#15N

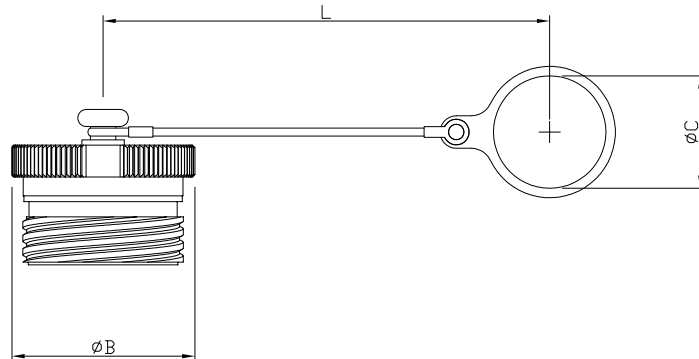

Shell Size	AB Part No.	CØ min	B Ø max	L +12.7 - 6.35	38999 Part No.
15	ABAC/32#15N	29.92	31.75	127	D38999/32#15N

# ABAC Panel cut out

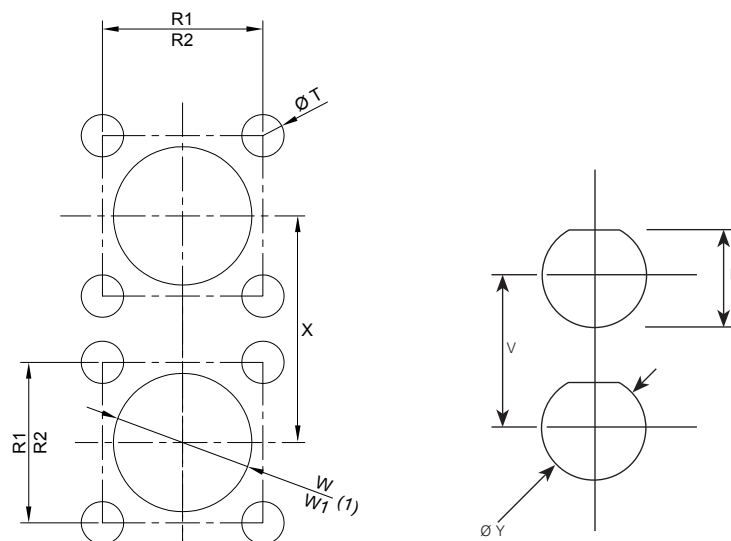

Shell Size	N-0.25	R1 rear mount	R2 front mount	T Ø +/- 0.13	V min	W min rear mount	W1 min front mount	X min -0.25	Ø Y
15	27.56	24.61	23.01	3.25	44.63	26.59	23.01	33.24	28.83



# Wiring and assembly instructions

- 1 Product Introduction
- 2 Cable termination
- 2.1 Termination of category 6/6a cable to 8P8C (RJ45) shielded modular plug
- 3 Tooling
- 3.1 Category 6/6a connector crimp tooling
- 4 Connector assembly
- 4.1 MIL-DTL-26482 and MIL-DTL-38999 derived 8P8C (RJ45) plugs
- 4.2 MIL-DTL-38999 derived USB cabled plugs

## 1 Product introduction

This high speed range of RJ45 and USB connectors are derived from MIL-DTL-26482 and MIL-DTL-38999 specifications. The range provides 360° EMC and mechanical protection and meets the requirements of high speed data applications where environmental protection is required.

## 2 Cable termination

### 2.1 Termination of category 6 cable to 8P8C (RJ45) shielded modular plug

The 8P8C (8 position, 8 conductor) modular plug that is required when terminating category 6 cable in conjunction with MIL-DTL-26482 and MIL-DTL-38999 derived connectors is a Bel Stewart Shielded 39200 Series connector.

Termination and assembly instructions can be found on the manufacturers' website at the following address:

<http://www.belfuse.com/Data/UploadedFiles/MN390009.pdf>

Note: Wiring example illustrated in the above assembly instructions is per EIA/TIA-568-B standard.

## 3 Tooling

### 3.1 Category 6 and 6a connector crimp tooling

Crimp tool  
AB part number M3800915.

Note: tool is suitable for use when cable OD is greater than 6mm.

Shielded 8P8C modular plug and load bar  
- supplied with connector.

(AB Part number M3800942  
for use if additional spare part required)



## 4 Connector assembly

### 4.1 MIL-DTL-26482 and MIL-DTL-38999 derived 8P8C (RJ45) plugs

- a. Slide the nut, cable seal and clamp barrel along the cable insulation as illustrated.
- b. Terminate the cable as described in section 2.
- c. Insert the modular plug into the connector housing, press home until the modular plug shield butts against the connector housing.  
Note: The modular plug latch will not 'click' into place.
- d. Slide the clamp barrel back down the cable and press home into the rear of the connector housing, ensuring the clamp barrel presses against the rear of the modular plug.
- e. Slide the cable seal into position at the rear of the clamp barrel.
- f. Slide the nut along the cable and securely attach to the rear of the connector housing. Tighten until the nut reaches a firm mechanical stop.

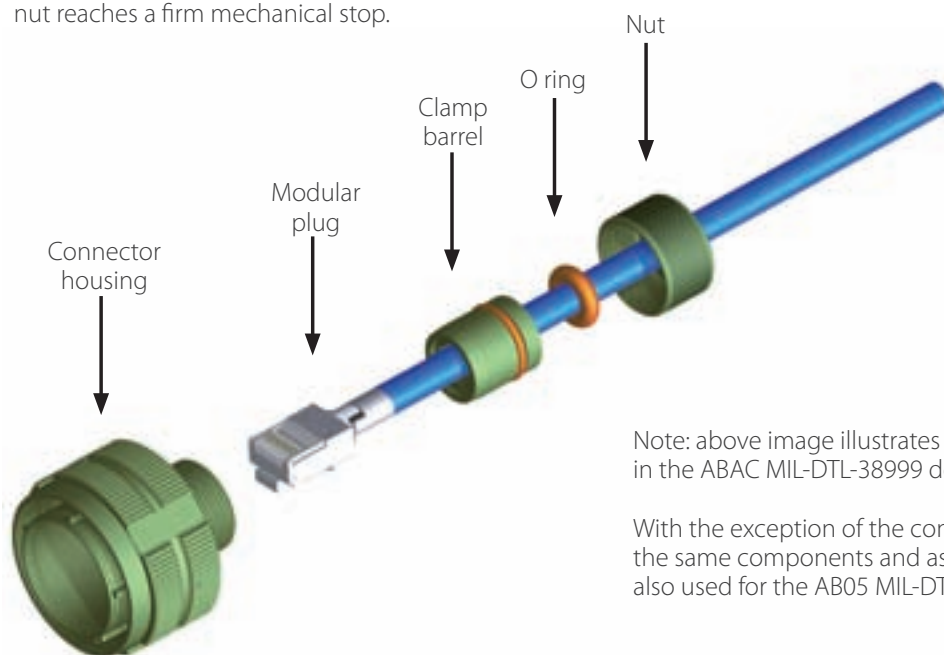

### 4.2 MIL-DTL-38999 derived USB cabled plugs

- a. Slide the nut and washer along the cable assembly as illustrated.
- b. Ensure that the O ring is seated in the position shown and insert the cable assembly into the connector housing, press home until the USB connector moulding seats against the inside face of the connector housing.
- c. Slide the washer into position at the rear of the USB connector moulding, follow with the nut. Screw the nut onto the rear of the connector housing, tighten until the nut reaches a firm mechanical stop.

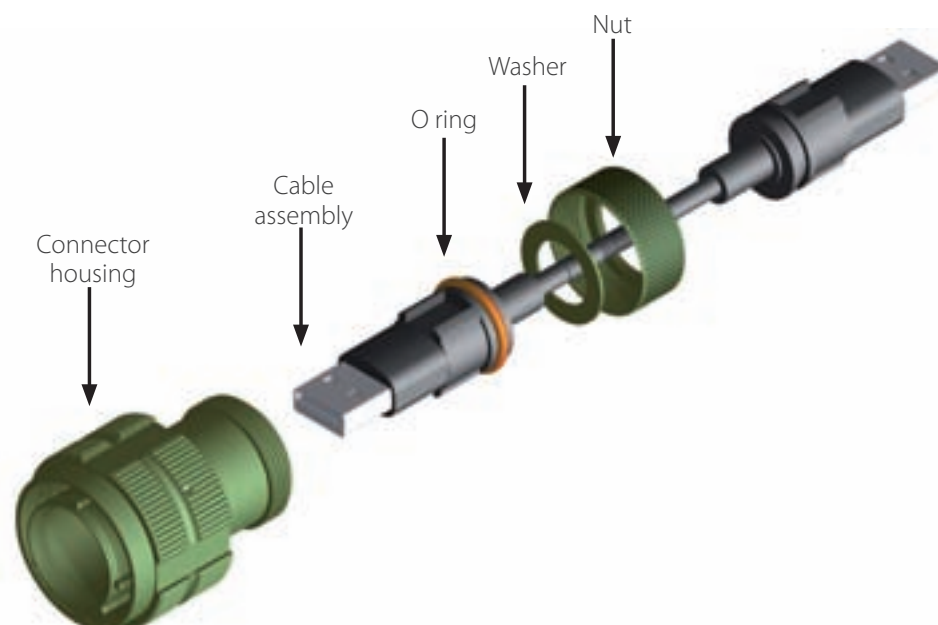

# FAQ

## What is the difference between CAT-5, CAT-5e, CAT-6, CAT-6A?

### ●Cat 5:

Out of the different types of cable, Category 5 is the most basic. Cat 5 cable is available in two varieties: Unshielded Twisted Pair (UTP), the type widely used in the United States, and Screened Twisted Pair (SCTP), which has shielding to provide a measure of extra protection against interference, but is rarely used outside of Europe. Cables belonging to Category 5 are either solid or stranded: Solid Cat 5 is more rigid, and the better choice if data needs to be transmitted over a long distance, while Stranded Cat 5 is very flexible and most likely to be used as patch cable. Cat 5 cable can support 10 or 100 Mbps Ethernet, and has a capability of up to 100MHz.

### ●Cat 5e:

Cat 5e (which stands for Category 5, enhanced) cable goes along the same lines as basic Cat 5, except that it fulfills higher standards of data transmission. While Cat 5 is common in existing cabling systems, Category 5e has almost entirely replaced it in new installations. Cat 5e can handle data transfer at 1000 Mbps, is suitable for Gigabit Ethernet, and experiences much lower levels of near-end crosstalk (NEXT) than Cat 5. CAT-5e is formally called ANSI/TIA/EIA 568A-5 or simply Cat-5e (the e stands for 'enhanced'). CAT-5e is completely backward compatible with current CAT-5 equipment. The enhanced electrical performance of CAT-5e ensures that the cable will support applications that require additional bandwidth, such as gigabit Ethernet or analog video.

### ●CAT 5 cable and CAT 5e cable have several differences, the most important are as follows:

Network support:

CAT 5 cable will support 10/100 Ethernet. That is, Ethernet and Fast Ethernet. CAT 5e cable will support Ethernet, Fast Ethernet, and Gigabit Ethernet. CAT 5e Cable is completely backwards compatible, and can be used in any application in which you would normally use CAT 5 cable.

Less cross talk :

Cross talk is the electrical interference that results when one wire's signal effects another wire's signal. CAT 5e cable has been improved over CAT 5 cable in this respect, and cross talk has been greatly reduced.

Bandwidth:

This is directly related to network support, in the sense that the bandwidth is the information-carrying capacity of a system. The greater the bandwidth, the greater the information-carrying capacity in a given period of time. CAT 5e cable is rated at 350 megahertz, and it is this increased bandwidth (compared to CAT 5 cable) that allows it to support Gigabit Ethernet. Cable of good quality can run near or at gigabit speeds, it just cannot be "certified" for this use.

### ●Cat 6:

Just like Cat 5 and Cat 5e, Category 6 cable is typically made up of four twisted pairs of copper wire, and has 23 gauge conductor wires as opposed to the slightly smaller 24 gauge for CAT-5e. But its capabilities far exceed those of other cable types because of one particular structural difference: a longitudinal separator. This separator isolates each of the four pairs of twisted wire from the others, which reduces crosstalk, allows for faster data transfer, and gives Category 6 cable twice the bandwidth of Cat 5. Cat 6 cable is also backward-compatible with any previously-existing Cat 5 and Cat 5e cabling found in older installations. Cat6 is designed especially for gigabit use, and is certified to operate at said speed.

### ●CAT6a:

CAT6a is an improved version of the CAT6 cabling, has twice the bandwidth and offers better performance. CAT6 cables are rated at 1Gbps while CAT6a cables can achieve up to 10Gbps. It is able to achieve this because it operates at 500Mhz; twice that of the 250Mhz operation of the CAT6 cables. CAT6 cables may be able to achieve 10Gbps but only in when short lengths of cable are used. CAT6a cables are also stricter when it comes to shielding and protection against alien crosstalk. Crosstalk occurs when the signal from one cable leaks into another. This can distort the signal through the introduction of noise and force the network devices to work at a slower speed. Because of this, CAT6a cables would work better in situations where it is to be bundled with a lot of other cables.



## What is the difference between 10BASE-T, 100BASE-T and 1000BASE-T?

### ●10BASE-T:

This is the IEEE standard that defines the requirement for sending information at 10 Mbps on unshielded twisted-pair cabling, and defines various aspects of running Ethernet on this cabling.

### ●100BASE-T:

This is the IEEE standard that defines the requirement for sending information at 100 Mbps on unshielded twisted-pair cabling, and defines various aspects of running baseband Ethernet on this cabling.

### ●1000BASE-T (also called Gigabit Ethernet):

This is the IEEE standard that defines the requirement for sending information at 1000 Mbps on unshielded twisted-pair cabling, and defines various aspects of running baseband Ethernet on this cabling.

### ●10GBASE-T (also called 10 Gigabit Ethernet):

This is the IEEE standard released in 2006 to provide 10 Gbit/s connections over unshielded or shielded twisted pair cables, over distances up to 100 metres (330 ft). 10GBASE-T cable infrastructure can also be used for 1000BASE-T allowing a gradual upgrade from 1000BASE-T using autonegotiation to select which speed to use. 10GBASE-T has latency in the range 2 to 4 microseconds compared to 1 to 12 microseconds on 1000BASE-T.

## What are the maximum lengths for cables?

### ●For Solid UTP:

Fast Ethernet 100baseT 100 Meters (328 feet)  
Twisted Pair Ethernet 10baseT 100 Meters (328 feet)

### ●Recommended maximum lengths for Patch Cables made from stranded cable:

Fast Ethernet 100baseT 10 Meters (33 feet)  
Twisted Pair Ethernet 10baseT 10 Meters (33 feet)

# Safety information

This information is to be used in conjunction with the Product Catalogue and Product Specification. Products may be safely used in the applications for which they have been designed and within the specified ratings and environments. If products are exposed to conditions outside the performance ratings or specified environments they may constitute a hazard. In particular it should be noted that:-

## 1. Material Content of Products.

Circular Connectors generally use metalwork parts made of copper, copper alloy, aluminium alloy, aluminium-bronze, phosphor-bronze or steel, which, dependant on the particular application, may be passivated and protected with cadmium or zinc plate – in conjunction with chromated or anodised surface finishes. The insulating materials can be either natural or synthetic rubber, together with plastic or glass filled plastic moulded parts. Contact materials vary with product type but are usually made of copper, copper alloy, nickel, phosphor-bronze, almel, chromel or steel.

## 2. Electric Shock, Burns and Fire.

Hazard can occur if the product is used outside the specified parameters or if the product is damaged, wrongly wired or poorly assembled, or poorly integrated into larger equipment, or contaminated with conductive fluids. Live circuit terminations must be protected and live circuits never broken by demating products.

Hotspots may be created when resistance is increased due to damage or incorrect integration particularly soldering, crimping or loose terminations. Overheating can cause breakdown of insulation, electric shot, burns or, ultimately, fire. In the event of fire noxious and/or toxic fumes may be released and, in these circumstances, any fire involving the product should be dealt with by personnel properly equipped.

Connector products with exposed terminators or contacts should not be used on the current supply side of a circuit with exposed contacts on an unmated product. Before making a circuit live, the product and wiring should be checked to ensure that there is no damage and no electrically conducting debris present. Circuit resistance checks should also be conducted before making the circuit live. Always ensure that the correct tools, (specified by AB Connectors Ltd.) are employed for crimping and assembly and that connectors are assembled and wired by properly trained personnel.

## 3. Disposal of Products.

Products should not be burnt.

## 4. Use Transport and Storage of Products.

Care must be exercised to avoid damage to any part of the products during transporting, storage or use. The products, as manufactured, are free of sharp edges. Abnormal transit or storage conditions and abuse during installation can give rise to damage. Products should not be used in a damaged condition. Improper storage (particularly of damaged products) can give rise to additional hazards particularly corrosion. Your attention is specifically drawn to the need of proper storage of products containing cadmium and you are advised to see the Guidance Note from the Health and Safety Executive on Cadmium - Health and Safety Precautions.

### Safety Rules

1. Ensure all conductor wires are capable of withstanding the electrical and environmental conditions of the application.
2. Always use the correct assembly tools for cables, contacts and connectors.
3. Make circuit resistance checks before making a circuit live.
4. Always protect live circuits and never demate a live connector.
5. Never use a damaged connector.
6. Never burn discarded connectors or cable.
7. IF IN DOUBT, ASK.

N. B. Additional information on the products and the materials used in them may be obtained from the Sales Department of AB Connectors Ltd.

## 5. Shelf life for rubber components

AB Connectors incorporate a number of rubber components within their connectors. Most rubbers change in physical properties during storage e.g. excessive hardening, softening, cracking or other surface degradation. These changes may be the result of particular factors or a combination of factors such as light, heat, humidity, oils or solvents.

With a few simple precautions the shelf life may be considerably lengthened.

The storage temperature should be between +5 and +25 degrees C. Direct contact with sources of heat such as boilers, radiators and direct sunlight should be avoided. It is advisable to cover any windows of storage rooms with a red or orange coating or screen. The relative humidity in the storeroom should be below 70%. Very moist or very dry conditions should be avoided. Condensation should not occur.

If the above recommendations are adhered to, then AB Connectors would warrant a shelf life of four years for its products.

**N. B. The company reserves the right and may change or vary specification without prior written notice.**

# TT electronics and the environment

## TT electronics companies adopt a responsible attitude towards the protection of the environment

We strive to meet the requirements of all applicable environmental laws and regulations, to continuously improve environmental performance and to contribute to long-term economic, environmental and social sustainability.

As part of TT electronics' Group Corporate Social Responsibility (CSR) Programme, we engage with industry bodies, like the Electronics Industry Citizenship Coalition (EICC) and Carbon Trust, to support these goals and to maintain ethical supply chains.

The CSR programme has opened up a network for TT electronics, across industry leading bodies, helping us to benchmark our environmental approach.

### Environmental Deployment:

- Each site is encouraged to attain the latest quality and environmental accreditation and companies have attained ISO 9001, ISO 14001, QS 900 and TS16949, where appropriate.
- Our companies utilise energy efficient means of manufacture and seek to reduce, reuse and recycle waste and arrange for disposal of other waste responsibly.

In collaboration with customers and suppliers, TT electronics' product and process development engineers work continuously to meet the demands of a more environmentally demanding market place. With every new vehicle platform, the increasing use of electronics enables improved techniques to be utilised for reducing emissions and improving fuel economy. The continued drive for a cleaner environment is behind research and development into future generations of vehicles and personal transport systems. Many of these will incorporate new and novel forms of power plants including hybrid engines, fuel cells and plug in electrics. These exciting and technically advanced power sources will be controlled using new generations of electronic functional systems incorporating technology from TT electronics in the form of components and systems.

TT electronics companies have invested, heavily, in design engineering, process control and modern manufacturing equipment. An essential part of product development is the validation of products to customer specific requirements. In most of our companies, this process is carried out in-house on independently certified test and validation facilities. We are committed to partnerships with suppliers and encourage a talented, fully involved and committed workforce to achieve our objectives.

Each of our businesses adopts a high level of customer focus, and is committed to continuous improvement by utilising tools and methods including lean manufacture, Kaizen and Six- Sigma.

We believe that the ultimate measure of quality is customer satisfaction and that continued growth must be based on optimising and improving our quality performance.

# Notes

A large rectangular area with horizontal dotted lines for taking notes.

## Land Based Vehicles

Components Division, Connectors Business Unit

<http://www.ttabconnectors.com/e-catalogues/LBV>



Scan QR Code to view our Land Based Vehicles Brochure

## Rail Vehicles

Components Division, Connectors Business Unit

[http://www.ttabconnectors.com/e-catalogues/Rail\\_Vehicles\\_Brochure](http://www.ttabconnectors.com/e-catalogues/Rail_Vehicles_Brochure)



Scan QR Code to view our Rail Vehicles Brochure

## Global Sales Offices



### North America

Email: [sales@ttelelectronics-na.com](mailto:sales@ttelelectronics-na.com)

### Europe

Email: [sales@ttelelectronicseurope.com](mailto:sales@ttelelectronicseurope.com)

### Asia

Email: [sales@ttelelectronicsasia.com](mailto:sales@ttelelectronicsasia.com)



**TT electronics** Clive House, 12-18 Queens Road, Weybridge, Surrey, KT13 9XB, UK  
[www.ttelelectronics.com](http://www.ttelelectronics.com) Email: [info@ttelelectronics.com](mailto:info@ttelelectronics.com)



AB Connectors Limited Abercynon, Mountain Ash, Rhondda Cynon Taff, CF45 4SF  
+44 (0) 1443 740331 [www.ttabconnectors.com](http://www.ttabconnectors.com) [sales@ttabconnectors.com](mailto:sales@ttabconnectors.com)

[www.ttelectronics.com](http://www.ttelectronics.com)