



# Low Cost Video Format Converter

## TW8809

### Description

The TW8809 is a low cost video format converter that can take either analog CVBS or 24-bit digital RGB format video and output these signals in ITU-R.656 format. The video sources can be scaled and de-interlaced, so that the ITU-R BT.656 output is already formatted to the desired resolution and in progressive format. In addition, the TW8809 has built-in OSD and image enhancement capabilities.

### Applications

- Rear seat entertainment
- Radio head unit

### Features

#### Analog Video Decoder

- NTSC (M, 4.43) and PAL (B, D, G, H, I, M, N, N combination), PAL (60), SECAM with automatic format detection
- Selectable differential or single ended CVBS input
- Supports two differential or 4 single-ended CVBS inputs
- 10-bit ADC and analog clamping circuit
- Fully programmable static gain or automatic gain control for the Y or CVBS channel
- Programmable white peak control for the Y or CVBS channel
- High quality adaptive 2D comb filter for both NTSC and PAL inputs
- PAL delay line for color phase error correction
- Image enhancement with 2D dynamic peaking and CTI
- Digital sub-carrier PLL for accurate color decoding
- Digital horizontal PLL and advanced synchronization processing for VCR playback and weak signal performance
- Programmable hue, brightness, saturation, contrast and sharpness

#### Digital Input

- Supports YCbCr/RGB 24-bit input

- Supports both BT.656 and BT.601 video formats
- Supports input resolutions up to 720p

#### Digital Output

- ITU-R BT.656 compatible YCbCr (4:2:2) output format
- Progressive ITU-R BT.656 output format for both interlaced and progressive inputs
- Output resolution up to SVGA (pseudo BT.656)

#### On Screen Display

- 256 font RAM and 512 display RAM
- Four windows font OSD with bordering/shadowing
- 1/2/3/4 bits/pixel
- Supports variable width (12/16), height (2~32)

#### Image Processing

- High quality scaler with both up/down and nonlinear scaling support
- Panorama/Water-glass scaling
- Built-in 2D de-interlacing function
- Programmable hue, brightness, saturation, contrast and sharpness
- Programmable cropping of input video and graphics
- Independent RGB gain and offset controls
- Programmable 8-bit Gamma correction for each color
- Operates in Frame Sync mode
- Black/White Stretch

#### Clock Generation

- Spread spectrum clock
- Selectable modulation frequency and spread width

#### Power Management

- Supports functional based independent power down
- 1.8/3.3 V operation

#### Miscellaneous

- Short to Battery Detection Test
- Short to Ground Detection Test
- Supports 2-wire serial bus interface
- Single 27MHz crystal
- 56 lead QFN (with Wetable Flanks)

# TW8809 Functional Block Diagram

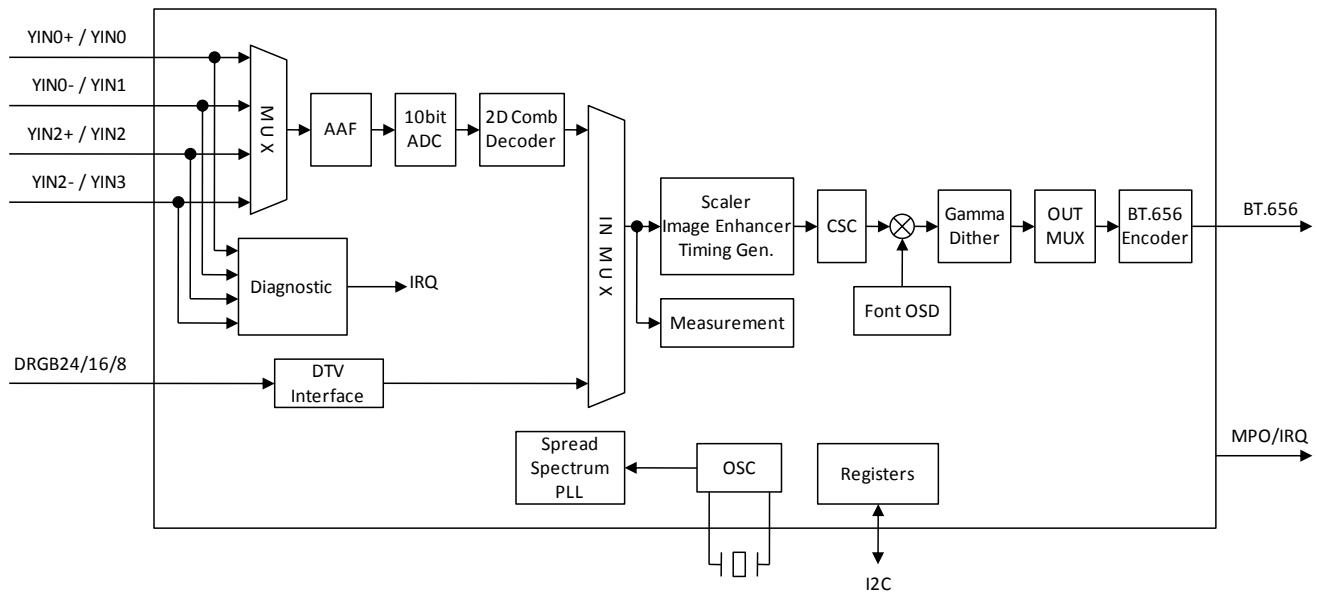

For additional products, see [www.intersil.com/product\\_tree](http://www.intersil.com/product_tree)

Intersil products are manufactured, assembled and tested utilizing ISO9001 quality systems as noted in the quality certifications found at [www.intersil.com/design/quality](http://www.intersil.com/design/quality)

*Intersil products are sold by description only. Intersil Corporation reserves the right to make changes in circuit design, software and/or specifications at any time without notice. Accordingly, the reader is cautioned to verify that data sheets are current before placing orders. Information furnished by Intersil is believed to be accurate and reliable. However, no responsibility is assumed by Intersil or its subsidiaries for its use; nor for any infringements of patents or other rights of third parties which may result from its use. No license is granted by implication or otherwise under any patent or patent rights of Intersil or its subsidiaries.*

For information regarding Intersil Corporation and its products, see [www.intersil.com](http://www.intersil.com)