

Spezifikation für Freigabe / specification for release

Kunde / customer :
 Artikelnummer / part number : **749020010A**
 Bezeichnung : **LAN-Übertrager WE-LAN**
 description : **LAN-Transformer WE-LAN**

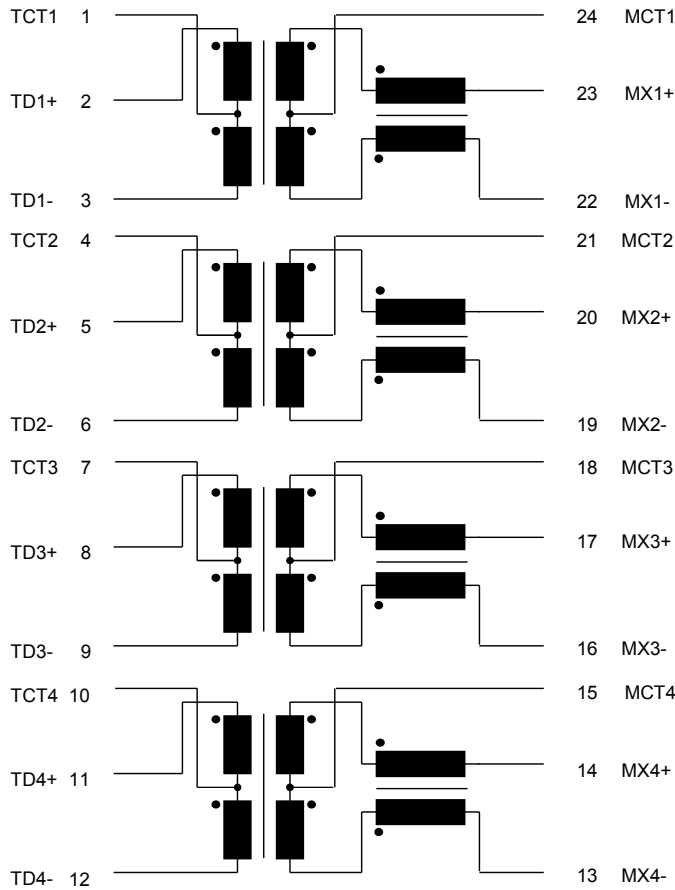

H Schaltbild / Schematics :



Freigabe erteilt / general release:	Kunde / customer			
Datum / date	Unterschrift / signature			
	Würth Elektronik	MLe	Rev 02	2012-11-28
		Mle	Rev 01	2012-10-31
		MLe	Rev 00	2012-10-10
Geprüft / checked	Kontrolliert / approved	Name	Änderung / modification	Datum / date

Würth Elektronik eISos GmbH & Co.KG

D-74638 Waldenburg · Max-Eyth-Straße 1 - 3 · Germany · Telefon (+49) (0) 7942 - 945 - 0 · Telefax (+49) (0) 7942 - 945 - 400
<http://www.we-online.com>

Spezifikation für Freigabe / specification for release

Kunde / customer :
 Artikelnummer / part number : **749020010A**
 Bezeichnung : **LAN-Übertrager WE-LAN**
 description : **LAN-Transformer WE-LAN**



DATUM / DATE : 2012-11-28

I Rollenspezifikation / tape and reel specification :

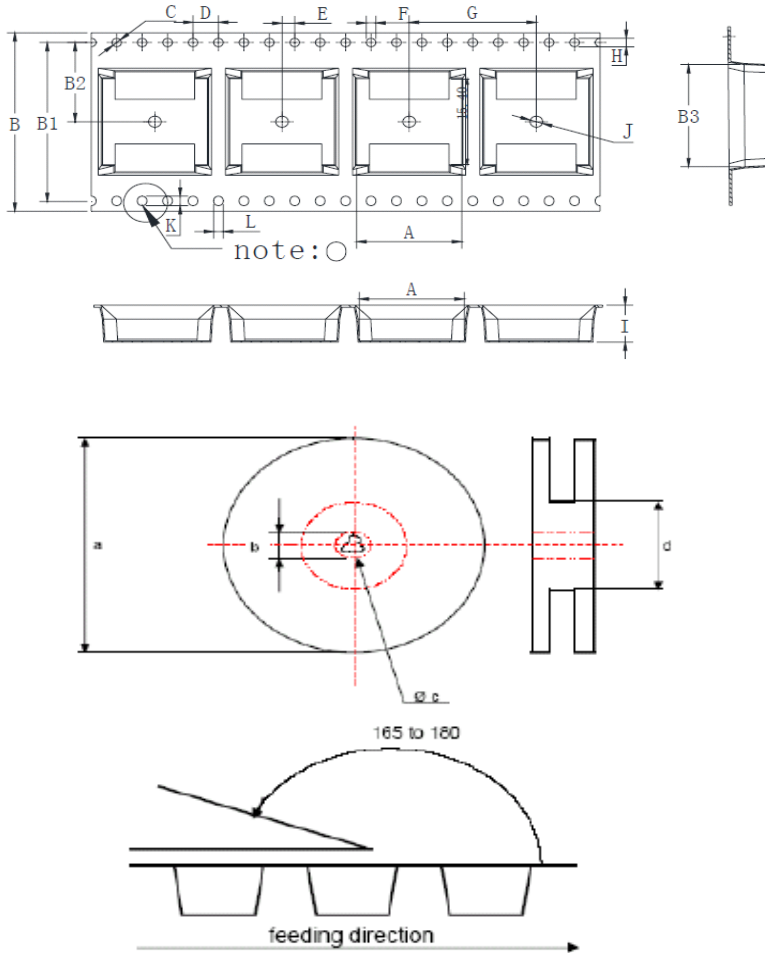

Gurtspezifikation / Tape specification:

A	16,50 ± 0,10	mm
B	32,00 ± 0,30	mm
B1	28,40 ± 0,10	mm
B2	14,20 ± 0,10	mm
B3	17,93 ± 0,10	mm
C	1,50 + 0,10/-0	mm
D	4,00 ± 0,10	mm
E	2,00 + 0,10	mm
F	1,50 + 0,10/-0	mm
G	20,00 ± 0,10	mm
H	1,50 + 0,10/-0	mm
I	6,60 ± 0,10	mm
J	2,00 + 0,10/-0	mm
K	1,70 + 0,10/-0	mm
L	1,50 + 0,10/-0	mm

Rollenspezifikation / Reel specification:

a	330,0 ± 2,0	mm
b	21,00 ± 0,8	mm
c	13,60 ± 0,5	mm
d	100,0 ± 1,0	mm

Freigabe erteilt / general release:	Kunde / customer			
Datum / date	Unterschrift / signature			
Geprüft / checked	Würth Elektronik	MLe	Rev 02	2012-11-28
		Mle	Rev 01	2012-10-31
		MLe	Rev 00	2012-10-10
	Kontrolliert / approved	Name	Änderung / modification	Datum / date

This electronic component has been designed and developed for usage in general electronic equipment. Before incorporating this component into any equipment where higher safety and reliability is especially required or if there is the possibility of direct damage or injury to human body, for example in the range of aerospace, aviation, nuclear control, submarine, transportation, (automotive control, train control, ship control), transportation signal, disaster prevention, medical, public information network etc, Würth Elektronik eiSos GmbH must be informed before the design-in stage. In addition, sufficient reliability evaluation checks for safety must be performed on every electronic component which is used in electrical circuits that require high safety and reliability functions or performance.

Würth Elektronik eiSos GmbH & Co.KG

D-74638 Waldenburg · Max-Eyth-Straße 1 - 3 · Germany · Telefon (+49) (0) 7942 - 945 - 0 · Telefax (+49) (0) 7942 - 945 - 400
<http://www.we-online.com>

Spezifikation für Freigabe / specification for release

Kunde / customer :
 Artikelnummer / part number : **749020010A**
 Bezeichnung : LAN-Übertrager WE-LAN
 description : LAN-Transformer WE-LAN



DATUM / DATE : 2014-01-10

A Mechanische Abmessungen / dimensions :

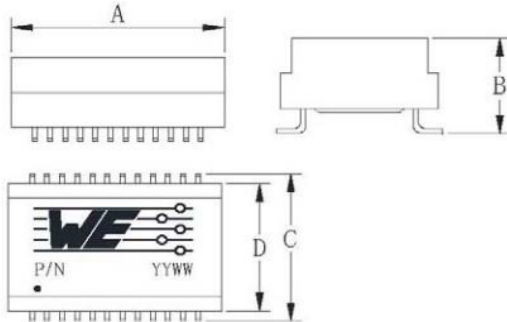

	1000 BaseT	
A	17,50 ± 0,25	mm
B	6,50 max.	mm
C	16,00 ± 0,25	mm
D	14,20 ± 0,25	mm

● = Pin 1

B Elektrische Eigenschaften / electrical properties :

Eigenschaften / properties	Testbedingungen / test conditions		Wert / value	Einheit / unit	tol.
Induktivität / Inductance	100kHz / 100mV @ 8mA DC-Bias	OCL	350	µH	min.
Übersetzungsverhältnis / Turns ratio	100kHz / 100mV	TR	1 : 1	Tx	3%
			1 : 1	Rx	
Insertion Loss	1-100MHz	IL	-1,0	dB	max.
Return Loss	1-40MHz @ 100Ω	RL	-18	dB	min.
	50MHz @ 100Ω		-16		
	60-80MHz @ 100Ω		-12		
	100MHz @ 100Ω		-10		
Differential to Common Mode Rejection	30MHz	DCMR	-43	dB	min.
	60MHz		-37		
	100MHz		-33		
Crosstalk	60MHz	CT	-40	dB	min.
	100MHz		-35		

C Lötpad / soldering spec. :

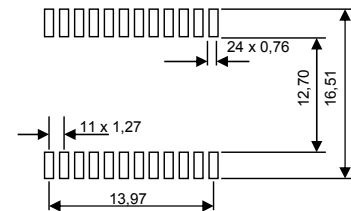

D Prüfgeräte / test equipment :

HP4395A

E Testbedingungen / test conditions :

Luftfeuchtigkeit / humidity: 33%
 Umgebungstemperatur / temperature: +25°C

F Werkstoffe & Zulassungen / material & approvals :

Basismaterial / base material: Ferrit/ ferrite
 Draht / wire: 4UEW 155°C
 Kontaktmaterial/ contact plating: Cu-Ni-Sn
 Gehäuse / case: UL94-V0
 Verguss / potting: UL94-V0

G Eigenschaften / general specifications :

Betriebstemp. / operating temperature: -40°C - + 85°C
 Hochspannungsprüfung / Hipot test: 1500Vrms 1min.
 Geeignet für 1000BaseT-Anwendungen gemäß IEEE 802.3ab /
 Compliant with IEEE 802.3ab for 1000BaseT
 Pins mit 5 µm Sn vor dem Heißverzinne /
 Pins with 5 µm Sn before hot dip soldering

Freigabe erteilt / general release:	Kunde / customer		
Datum / date	Unterschrift / signature		
Geprüft / checked	Würth Elektronik		
	MLe	Rev 03	2014-01-10
	MLe	Rev 02	2012-11-28
	MLe	Rev 01	2012-10-31
Geprüft / checked	Kontrolliert / approved		Datum / date
	Name	Änderung / modification	Datum / date

Würth Elektronik eiSos GmbH & Co.KG

D-74638 Waldenburg · Max-Eyth-Straße 1 - 3 · Germany · Telefon (+49) (0) 7942 - 945 - 0 · Telefax (+49) (0) 7942 - 945 - 400
<http://www.we-online.com>

Spezifikation für Freigabe / specification for release

Kunde / customer :
 Artikelnummer / part number : **749020010A**
 Bezeichnung : **LAN-Übertrager WE-LAN**
 description : **LAN-Transformer WE-LAN**



DATUM / DATE : 2014-01-10

H Schaltbild / Schematics :

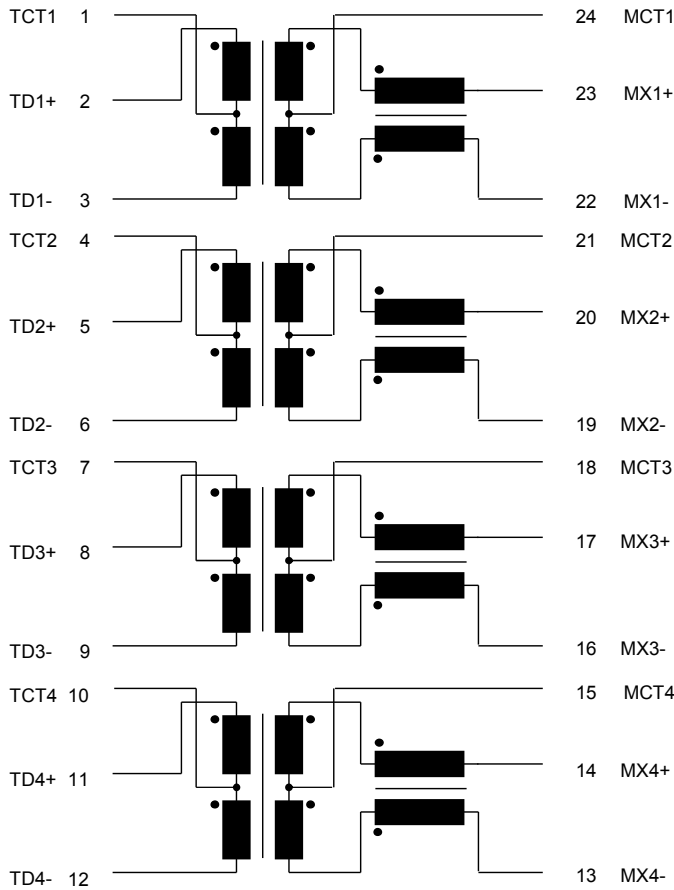

Freigabe erteilt / general release:	Kunde / customer			
.....			
Datum / date	Unterschrift / signature	MLe	Rev 03	2014-01-10
.....	Würth Elektronik	MLe	Rev 02	2012-11-28
.....	Mle	Rev 01	2012-10-31
.....	MLe	Rev 00	2012-10-10
Geprüft / checked	Kontrolliert / approved	Name	Änderung / modification	Datum / date

Würth Elektronik eISos GmbH & Co.KG

D-74638 Waldenburg · Max-Eyth-Straße 1 - 3 · Germany · Telefon (+49) (0) 7942 - 945 - 0 · Telefax (+49) (0) 7942 - 945 - 400
<http://www.we-online.com>

Spezifikation für Freigabe / specification for release

Kunde / customer :
 Artikelnummer / part number : **749020010A**
 Bezeichnung : **LAN-Übertrager WE-LAN**
 description : **LAN-Transformer WE-LAN**



DATUM / DATE : 2014-01-10

I Rollenspezifikation / tape and reel specification :

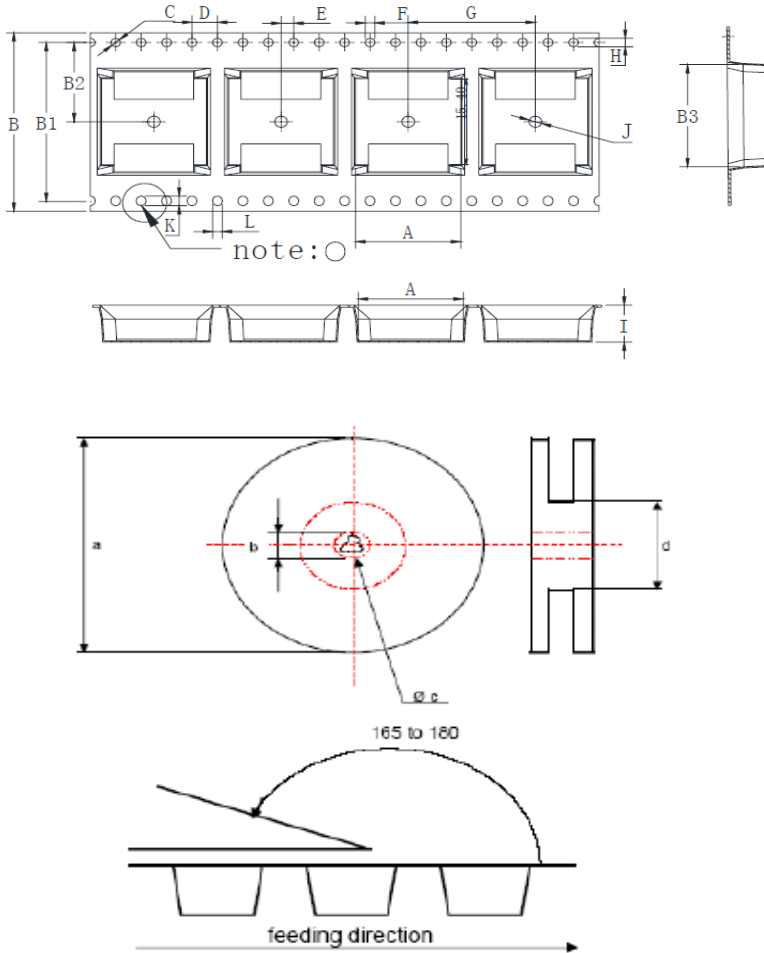

Gurtspezifikation / Tape specification:

A	16,50 ± 0,10	mm
B	32,00 ± 0,30	mm
B1	28,40 ± 0,10	mm
B2	14,20 ± 0,10	mm
B3	17,93 ± 0,10	mm
C	1,50 + 0,10/-0	mm
D	4,00 ± 0,10	mm
E	2,00 ± 0,10	mm
F	1,50 + 0,10/-0	mm
G	20,00 ± 0,10	mm
H	1,50 + 0,10/-0	mm
I	6,60 ± 0,10	mm
J	2,00 + 0,10/-0	mm
K	1,70 + 0,10/-0	mm
L	1,50 + 0,10/-0	mm

Rollenspezifikation / Reel specification:

a	330,0 ± 2,0	mm
b	21,00 ± 0,8	mm
c	13,60 ± 0,5	mm
d	100,0 ± 1,0	mm

Freigabe erteilt / general release:	Kunde / customer			
Datum / date	Unterschrift / signature	MLe	Rev 03	2014-01-10
Geprüft / checked	Kontrolliert / approved	MLe	Rev 02	2012-11-28
		MLe	Rev 01	2012-10-31
		MLe	Rev 00	2012-10-10
		Name	Änderung / modification	Datum / date

This electronic component has been designed and developed for usage in general electronic equipment. Before incorporating this component into any equipment where higher safety and reliability is especially required or if there is the possibility of direct damage or injury to human body, for example in the range of aerospace, aviation, nuclear control, submarine, transportation, (automotive control, train control, ship control), transportation signal, disaster prevention, medical, public information network etc, Würth Elektronik eiSos GmbH must be informed before the design-in stage. In addition, sufficient reliability evaluation checks for safety must be performed on every electronic component which is used in electrical circuits that require high safety and reliability functions or performance.

Würth Elektronik eiSos GmbH & Co.KG

D-74638 Waldenburg · Max-Eyth-Straße 1 - 3 · Germany · Telefon (+49) (0) 7942 - 945 - 0 · Telefax (+49) (0) 7942 - 945 - 400
<http://www.we-online.com>