

NCP1521BEVB

NCP1521B Adjustable Output Voltage Step-Down Converter Evaluation Board User's Manual



ON Semiconductor®

<http://onsemi.com>

EVAL BOARD USER'S MANUAL

Overview

The NCP1521B step-down PWM DC-DC converter is optimized for portable applications powered from one cell Li-ion or three cell Alkaline/NiCd/NiMH batteries.

The part is available in adjustable output voltage versions ranging from 0.9 V to 3.3 V. It uses synchronous rectification to increase efficiency and reduce external part count. The device also has a built-in 1.5 MHz (nominal) oscillator

which reduces component size by allowing smaller inductors and capacitors. Automatic switching PWM/PFM mode offers improved system efficiency.

Additional features include integrated soft-start, cycle-by-cycle current limiting and thermal shutdown protection. The NCP1521B is available in space saving, low profile TSOP5 and UDFN6 packages.

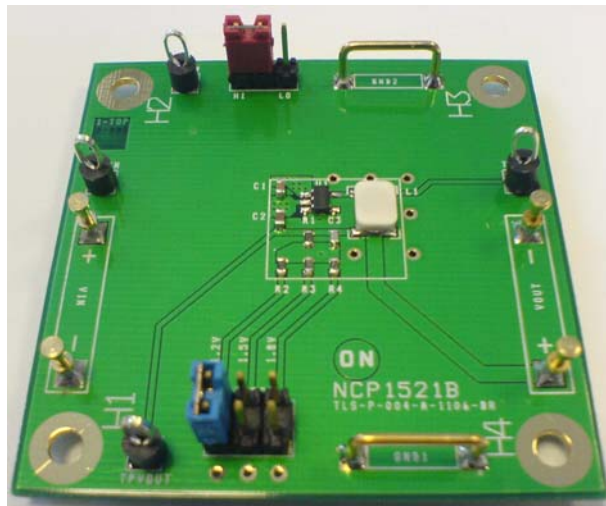

Figure 1. Board Picture in TSOP-5

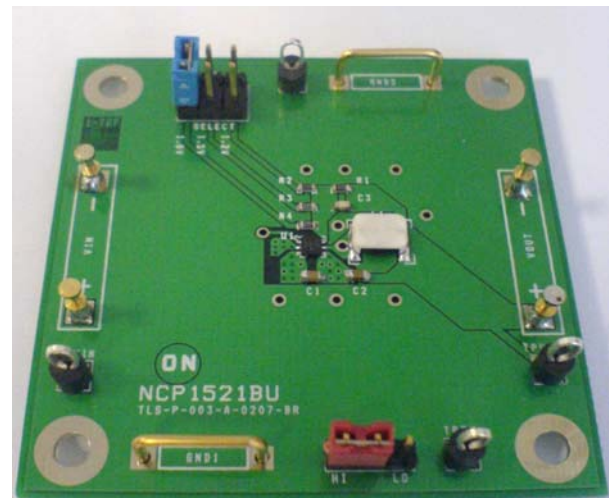

Figure 2. Board Picture in μDFN-6

NCP1521BEVB

MAXIMUM RATINGS

Maximum ratings are those values beyond which damage to the device may occur. Exposure to these conditions or conditions beyond those indicated may adversely affect device reliability. Functional operation under absolute maximum-rated conditions is not implied. Functional operation should be restricted to the Recommended Operating Conditions (Note 1).

Rating	Symbol	Value	Unit
Minimum Voltage All Pins	V_{min}	-0.3	V
Maximum Voltage All Pins (Note 2)	V_{max}	7.0	V
Maximum Voltage EN1, EN2, FB, LX	V_{max}	$V_{IN} + 0.3$	V
Thermal Resistance Junction-to-Air	$R_{\theta ja}$	300 260	°C/W
		TSOP-5 UDFN-6	
Operating Ambient Temperature Range	T_A	-40 to 85	°C
Storage Temperature Range	T_{stg}	-55 to 150	°C
Junction Operating Temperature	T_J	-40 to 125	°C
Latch-up current maximum rating $T_a=85^\circ\text{C}$ (Note 4) other pins	I_u	± 100	mA
ESD Withstand Voltage (Note 3)	V_{esd}	2.0 200	kV V
		Human Body Model Machine Model	
Moisture Sensitivity Level (Note 5)	MSL	1	per IPC

Stresses exceeding Maximum Ratings may damage the device. Maximum Ratings are stress ratings only. Functional operation above the Recommended Operating Conditions is not implied. Extended exposure to stresses above the Recommended Operating Conditions may affect device reliability.

1. Maximum electrical ratings are defined as those values beyond which damage to the device may occur at $T_A = 25^\circ\text{C}$
2. According JEDEC standard JESD22-A108B
3. This device series contains ESD protection and exceeds the following tests:
Human Body Model (HBM) per JEDEC standard: JESD22-A114
Machine Model (MM) per JEDEC standard: JESD22-A115
4. Latchup current maximum rating per JEDEC standard: JESD78.
5. JEDEC Standard: J-STD-020A.

ELECTRICAL CHARACTERISTICS

For Electrical Characteristic, please see our NCP1521B datasheet available at <http://www.onsemi.com/PowerSolutions/product.do?id=NCP1521B>

NCP1521B – BOARD CONNECTIONS

Symbol	Switch Descriptions
--------	---------------------

INPUT POWER

V_{IN+}	This is the positive connection for power supply.
V_{IN-}	This is the return connection for the power supply
GND1, GND2	Ground clip

SETUP

ENABLE	To enable the buck converter, connect a shorting jumper between ENABLE-1 and ENABLE-2. To disable the buck converter, connect a shorting jumper between ENABLE-3 and ENABLE-2.
SELECT	A shorting jumper must be used to select an output voltage of 1.2 V, 1.5 V or 1.8 V

OUTPUT POWER

V_{OUT+}	This is the positive connection of the output voltage.
V_{OUT-}	This is the return connection of the output voltage.

TEST POINT

T_{PVIN}	This is the test point of the input voltage.
T_{PEN}	This is the test point of the enable pin.
T_{PLX}	This is the test point of the inductor voltage.
T_{PVOU}	This is the test point of the output voltage.

NCP1521BEVB

NCP1521B – BOARD SCHEMATIC

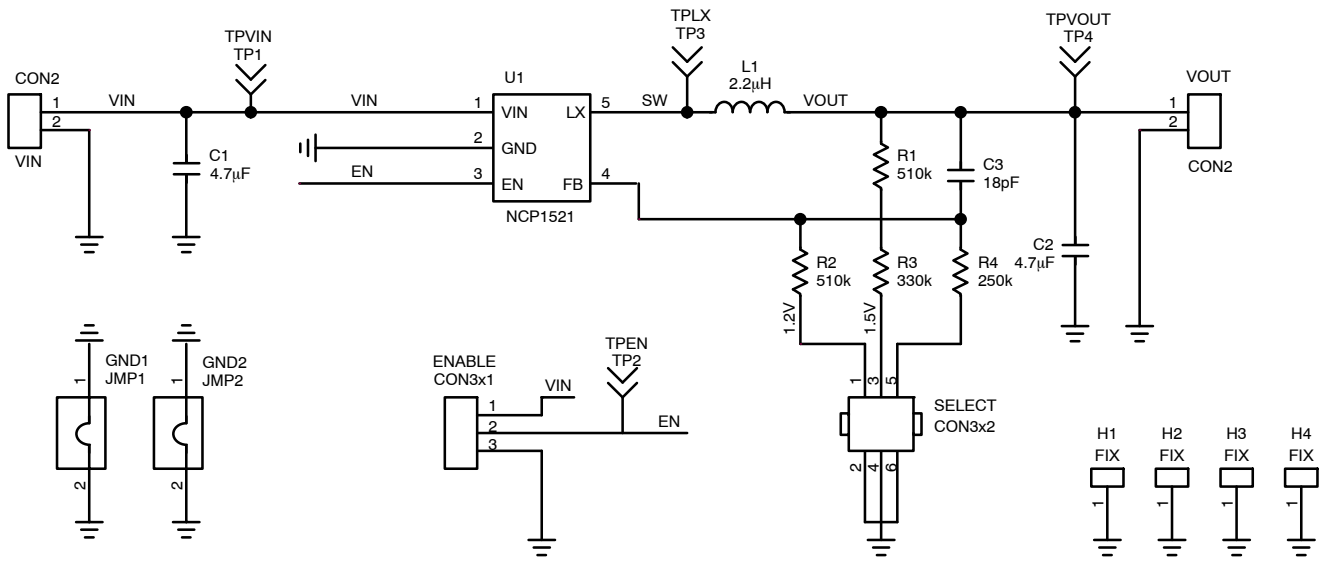

Figure 3. Board Schematic in TSOP-5

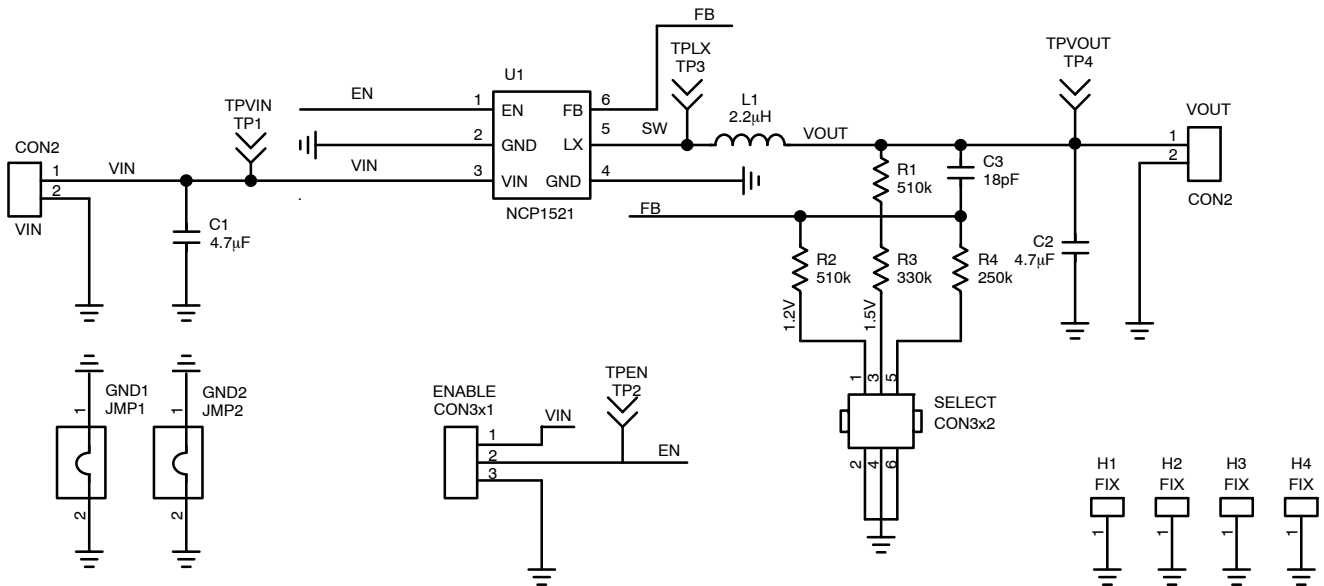

Figure 4. Board Schematic in µDFN-6

NCP1521BEVB

NCP1521B – TEST PROCEDURE

Equipment needed

- 10 pt. Times (*list:bull2*)
- Power supply
- Digital Volt Meter
- Digital Amp Meter

Test

1. Jumper ENABLE should be open.
2. Jumper SELECT should be closed to 1.2 V.
3. Set the power supply to 3.6 V and the current limit of at least 800 mA.
4. Connect the power supply connector to connectors V_{IN+} and V_{IN-} . The DC current measurement on V_{IN} line should be around 0.3 μ A.
5. Close ENABLE connector. The DC current measurement on V_{IN} line should be around 40 μ A.
6. Measure the output voltage between V_{OUT+} and V_{OUT-} connectors. You should see around 1.2 V voltage operation.
7. Remove the ENABLE jumper. The DC current measurement on V_{IN} line should be back around 0.3 μ A.

NCP1521B – BILL OF MATERIAL

Designator	Qty	Description	Value	Tolerance	Foot-print	Manufacturer	Manufacturer Part Number
U1	1	IC, Converter, DC/DC	NA	NA	TSOP5 UDFN	ON Semiconductor	NCP1521B NCP1521BU
C1	1	Ceramic capacitor	4.7 μ F, 10 V, X5R	10%	0805	TDK	C1608X5R1A475
C2	1	Ceramic capacitor	10 μ F, 6.3 V, X5R	10%	0603	TDK	C1608X5R0J105
C3	1	Ceramic capacitor	18 pF, 50 V, COG	5%	0603	TDK	C1608C0G1H180
R1, R2	2	SMD resistor	510k	1%	0603	std	std
R3	1	SMD resistor	330k	1%	0603	std	std
R4	1	SMD resistor	240k	1%	0603	std	std
L1	1	Inductor	2.2 μ H	30%	1210	Coilcraft	LPS3008-222NL
VIN, VOUT	4	Connector	NA	NA	NA	Kontek Comatel Cambion	3110014000500 160-1724-02-05-00
ENABLE	1	3 Pin Jumper Header	NA	NA	2.54mm	TYCO/AMP Molex / Waldom	5-826629-0 90120-0160
SELECT	1	3x2 Pin Jumper Header	NA	NA	2.54mm	TYCO/AMP Molex / Waldom	4731955180470 90131-0140
GND1, GND2	2	Jumper for GND	NA	NA	10.16mm	Harwin Molex / Waldom	D3082-01 90120-0160
TPEN, TPLX, TPVIN, TPVOUT	4	Test point type 3	NA	NA	ϕ 1.60mm	Keystone	5010
PCB	1	50.8mm x 50.8mm x 1.0 mm 4 Layers	NA	NA	NA	Any	TLS-P-004-A-1106-BR TLS-P-003-A-0207-BR

NCP1521BEVB

NCP1521B – PCB LAYOUT

Board Reference: TLS-P-004-A-1106-BR

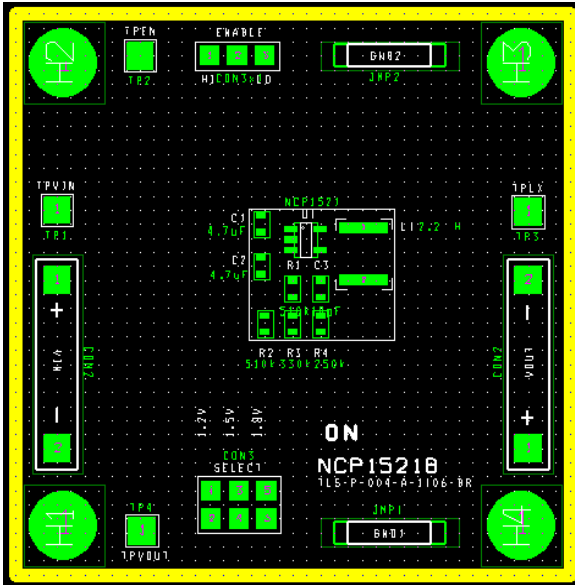

Figure 5. Assembly Layer in TSOP-5

Board Reference: TLS-P-003-A-0207-BR

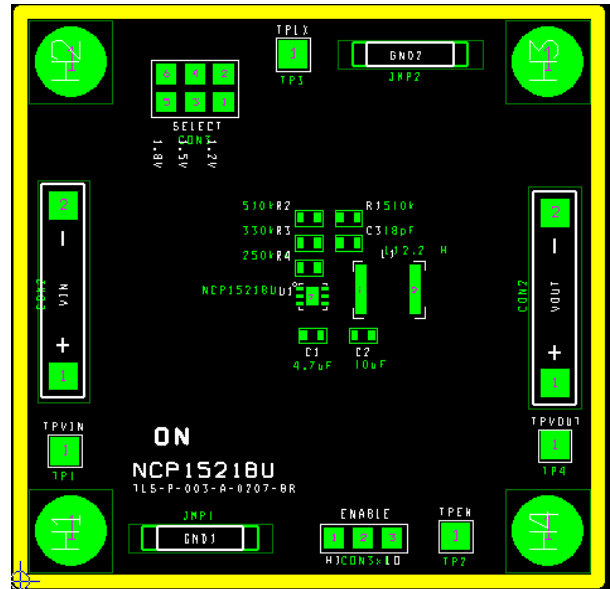

Figure 6. Assembly Layer in μ DFN-6

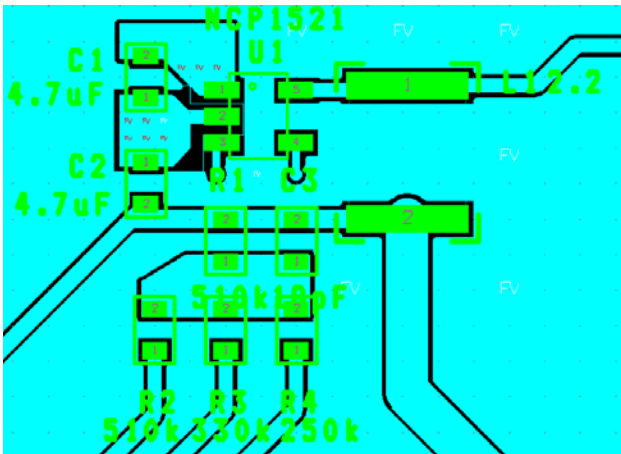

Figure 7. Part Layout in TSOP-5

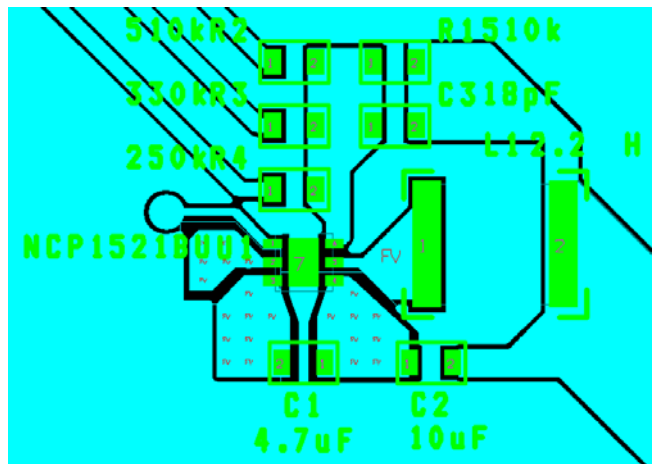

Figure 8. Part Layout in μ DFN-6

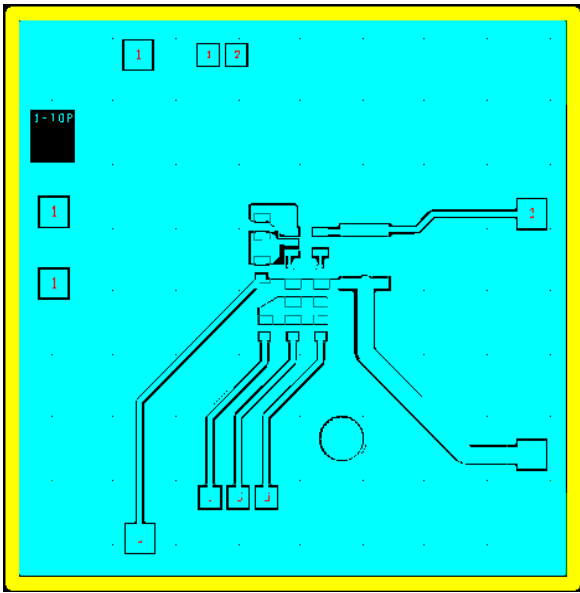

Figure 9. Top Layer Routing in TSOP-5

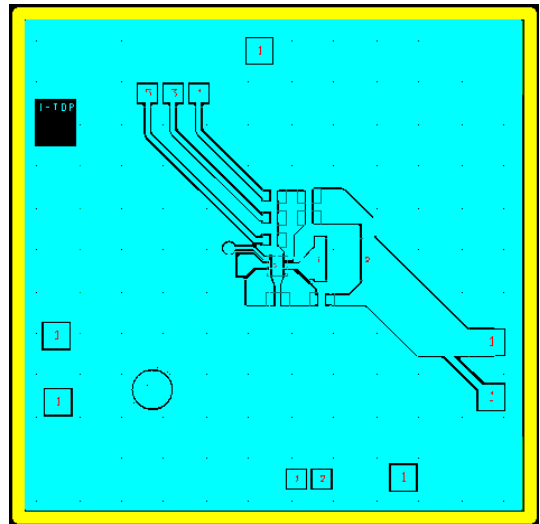

Figure 10. Top Layer Routing in μDFN-6

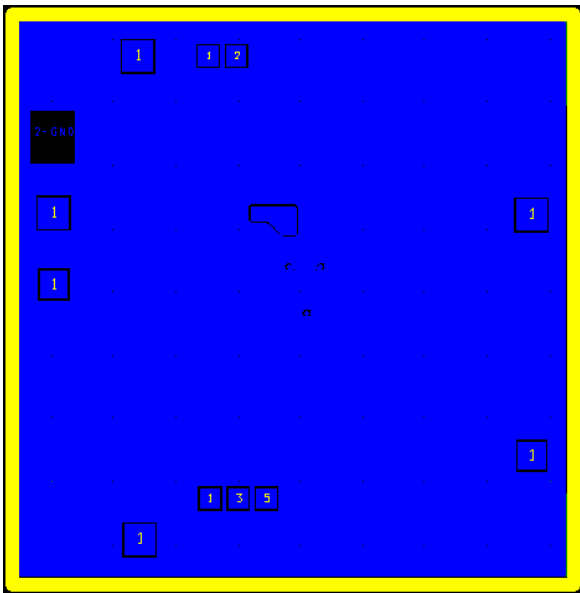

Figure 11. Ground Layer Routing in TSOP-5

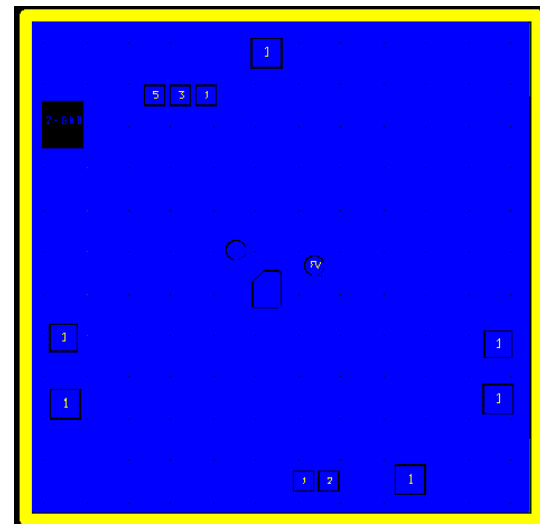

Figure 12. Ground Layer Routing in μDFN-6

NCP1521BEVB

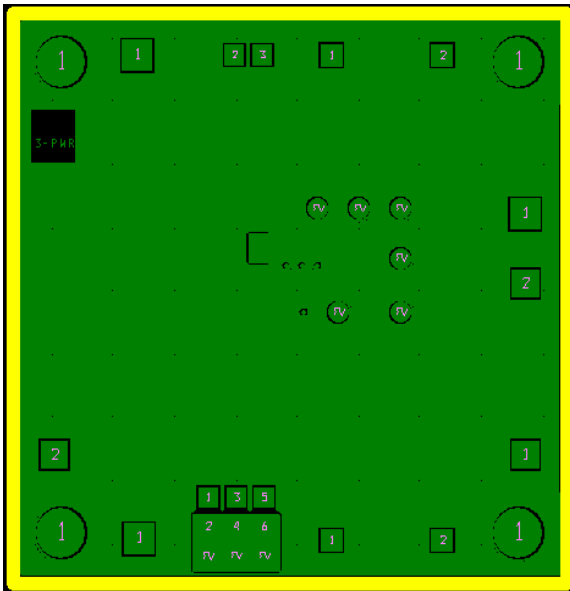

Figure 13. Power Layer Routing in TSOP-5

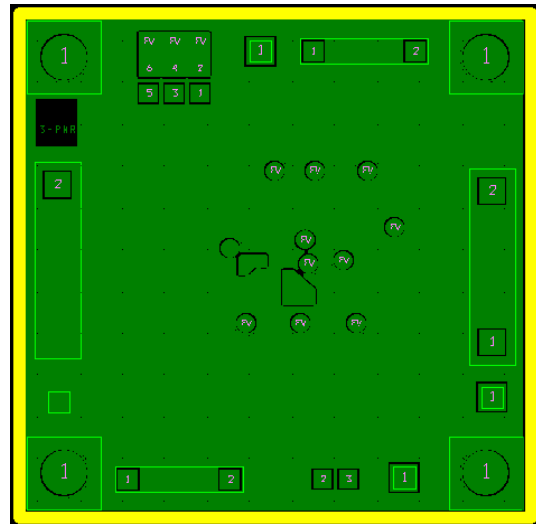

Figure 14. Power Layer Routing in μ DFN-6

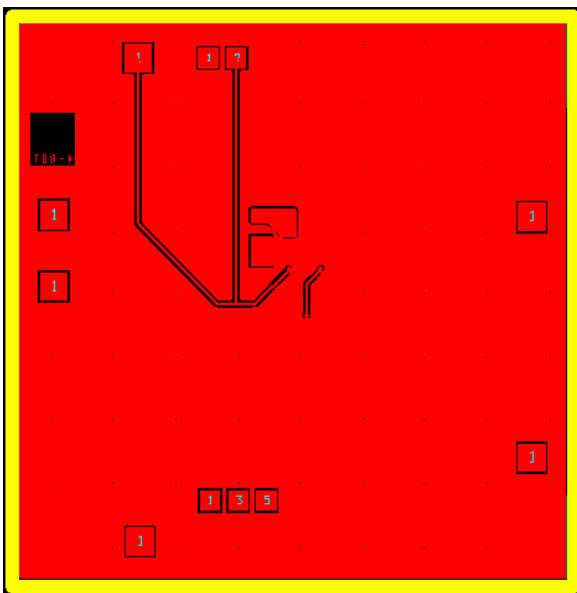

Figure 15. Bottom Layer Routing in TSOP-5

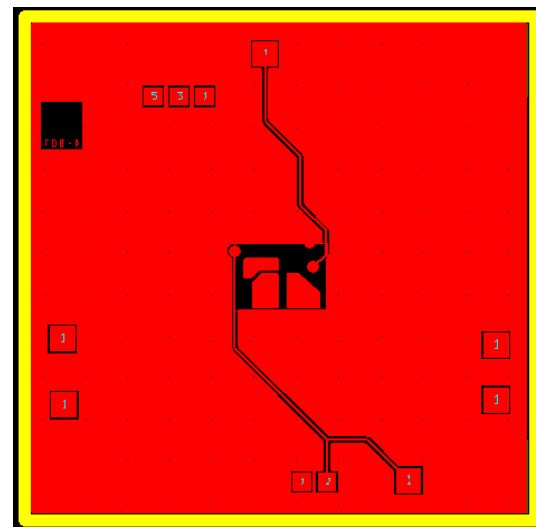

Figure 16. Bottom Layer Routing in μ DFN-6

ON Semiconductor and **ON** are registered trademarks of Semiconductor Components Industries, LLC (SCILLC). SCILLC reserves the right to make changes without further notice to any products herein. SCILLC makes no warranty, representation or guarantee regarding the suitability of its products for any particular purpose, nor does SCILLC assume any liability arising out of the application or use of any product or circuit, and specifically disclaims any and all liability, including without limitation special, consequential or incidental damages. "Typical" parameters which may be provided in SCILLC data sheets and/or specifications can and do vary in different applications and actual performance may vary over time. All operating parameters, including "Typicals" must be validated for each customer application by customer's technical experts. SCILLC does not convey any license under its patent rights nor the rights of others. SCILLC products are not designed, intended, or authorized for use as components in systems intended for surgical implant into the body, or other applications intended to support or sustain life, or for any other application in which the failure of the SCILLC product could create a situation where personal injury or death may occur. Should Buyer purchase or use SCILLC products for any such unintended or unauthorized application, Buyer shall indemnify and hold SCILLC and its officers, employees, subsidiaries, affiliates, and distributors harmless against all claims, costs, damages, and expenses, and reasonable attorney fees arising out of, directly or indirectly, any claim of personal injury or death associated with such unintended or unauthorized use, even if such claim alleges that SCILLC was negligent regarding the design or manufacture of the part. SCILLC is an Equal Opportunity/Affirmative Action Employer. This literature is subject to all applicable copyright laws and is not for resale in any manner.

PUBLICATION ORDERING INFORMATION

LITERATURE FULFILLMENT:
Literature Distribution Center for ON Semiconductor
P.O. Box 5163, Denver, Colorado 80217 USA
Phone: 303-675-2175 or 800-344-3860 Toll Free USA/Canada
Fax: 303-675-2176 or 800-344-3867 Toll Free USA/Canada
Email: orderlit@onsemi.com

N. American Technical Support: 800-282-9855 Toll Free
USA/Canada
Europe, Middle East and Africa Technical Support:
Phone: 421 33 790 2910
Japan Customer Focus Center
Phone: 81-3-5817-1050

ON Semiconductor Website: www.onsemi.com
Order Literature: <http://www.onsemi.com/orderlit>
For additional information, please contact your local
Sales Representative