

BD555BKFV AC/DC Controller IC for mains dimmable LED lighting

BD555BKFV

●General Description

The BD555BKFV controller AC/DC controller IC can be used in a wide range of dimmable LED lighting driver applications. The main target application is dimmable retro-fit LED lighting, replacing existing incandescent light bulbs, halogen spot lights, CFL tubes etc.

●Features

- Fixed frequency DC/DC controller (selectable)
- Peak current or average current control (PCC/ACC)
- Dynamic Load Current Controller (DLCC)
- Logarithmic compensation of detected dimming level
- Dimmer detector function
- Anti-flash function when dimmer is OFF
- PWM and analog dimming control supported
- Over Current Protection (OCP)
- Thermal Shutdown protection (TSD)
- Under Voltage Lock Out (UVLO)

●Applications

- Retro-fit dimmable LED lighting (E27, E14, GU10, T8 etc.). Wide range of TRIAC and transistor dimmers supported by DLCC function.
- Custom LED lighting with PWM or voltage controlled dimming.

●Key Specifications

- Input voltage range.....16~39V
- Regulated supply voltage.....11.5V
- Fixed DC/DC operating frequency.....40~400kHz
- Detectable phase-cut range.....45°~135°
- Typical current consumption.....1mA
- Under Voltage Lock Out detection.....9.0V
- Operating temperature range.....-40~+110°C

●Package

SSOP-B14

W(Typ.) x D(Typ.) x H(Max.)
5.00mm x 6.40mm x 1.15mm



●Typical Application Circuits

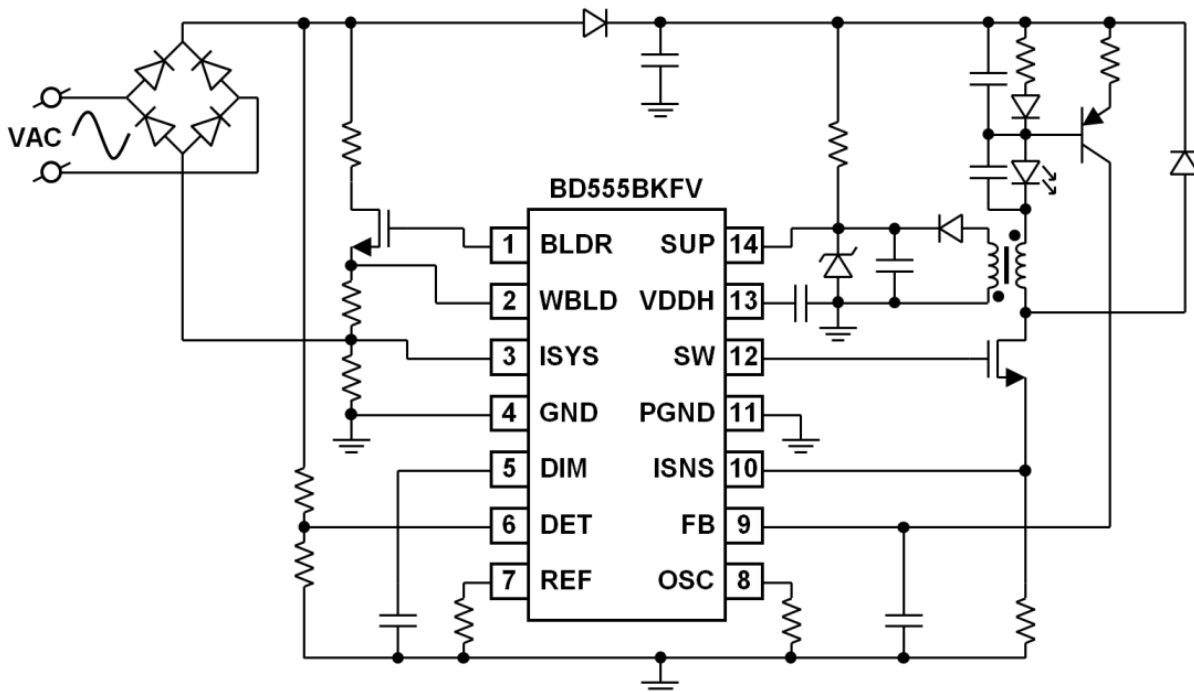

Figure 1. Typical application circuit for non-isolated dimmable buck topology

● Pin Configuration

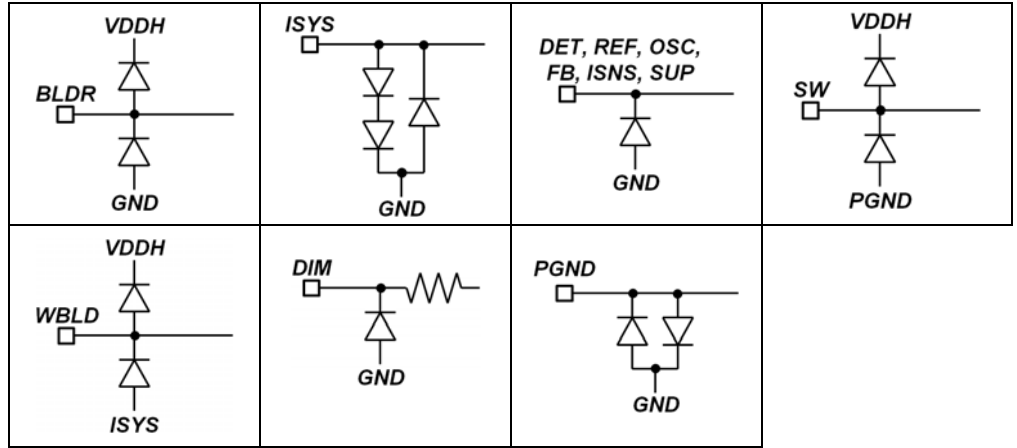
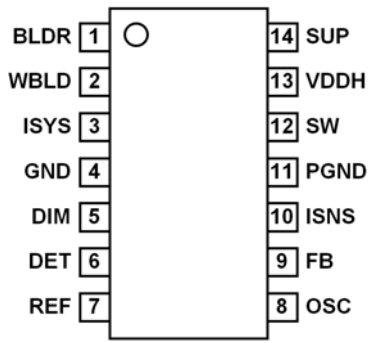

Figure 2. Pin configuration

Figure 3. Equivalent circuit

● Pin Description

Pin	Pin name	I/O	Function
1	BLDR	Out	Driver for dynamic load current controller (DLCC) transistor
2	WBLD	In	Internal strong load current input (connected to internal 'open drain' NMOS)
3	ISYS ^{*1}	In/Out	Sense voltage input for DLCC ON/OFF function
4	GND	-	Ground terminal
5	DIM	In/Out	Detected dimming level reference voltage
6	DET	In	Input for detecting phase-cut angle
7	REF ^{*2}	Out	Pin for external resistor to set LED current (average current control mode)
8	OSC ^{*2}	Out	Pin for external resistor to set DC/DC operating frequency
9	FB ^{*3}	In	Average current feedback input or PCC mode selection ($V_{FB} < 1.5V$)
10	ISNS	In	Sense voltage for peak current regulation & over current protection (OCP)
11	PGND ^{*4}	-	Ground terminal for internal BLDR and SW driver stages
12	SW	Out	Driver output for gate of external DC/DC switching MOSFET
13	VDDH	In/Out	Regulated supply voltage
14	SUP	In	Input supply voltage

*1 Between ISYS and GND are internal anti-parallel surge diodes

*2 Connect only resistive load according to application instructions

*3 FB terminal is 'pre-charged' to 4V during start-up in order to have smooth start of the LED current regulation. Never connect this pin directly to GND.

*4 Between GND and PGND are internal anti-parallel diodes

● Block Diagram

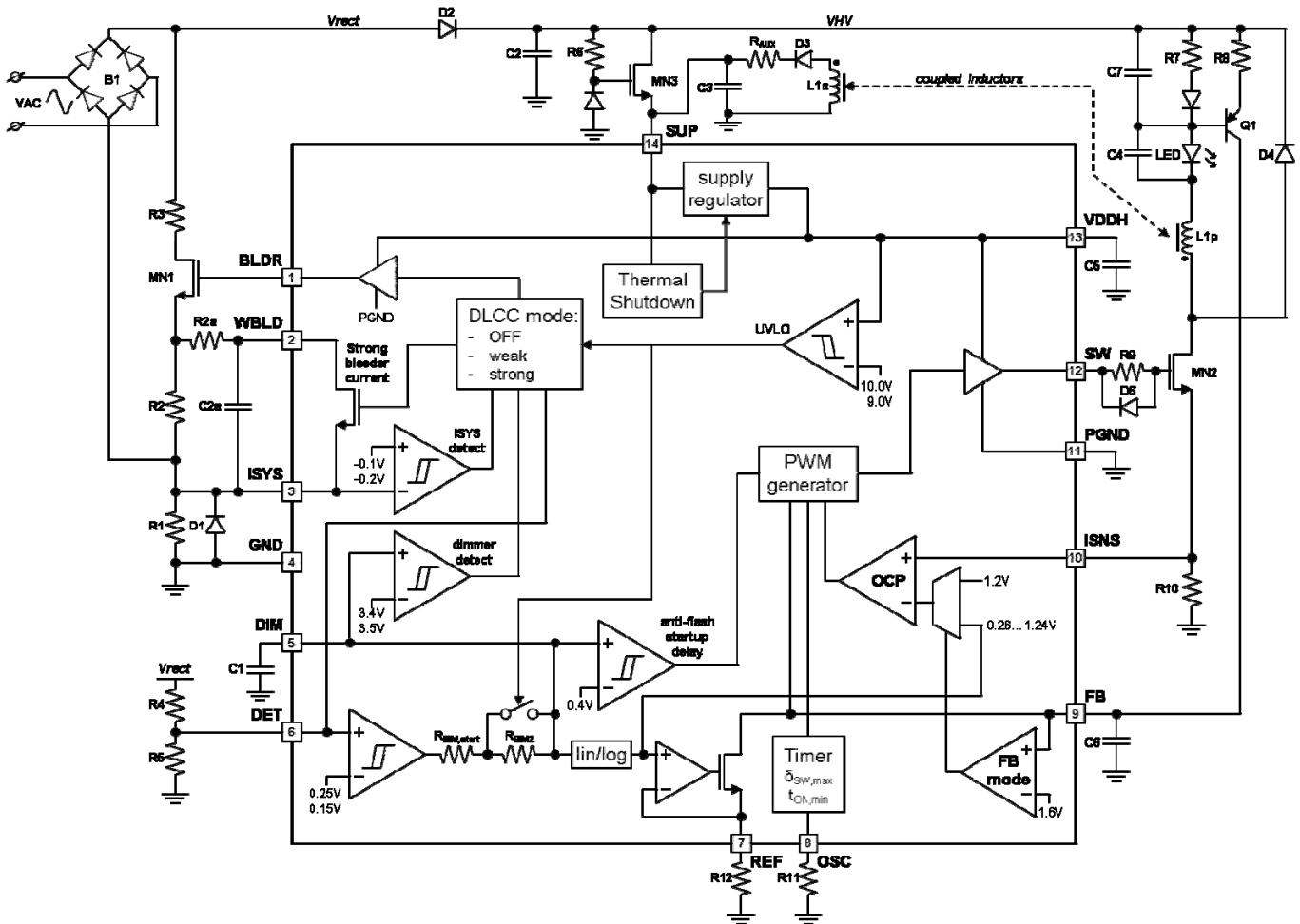

Figure 4. Block diagram

● Description of Blocks

Startup sequence: When an AC input voltage is applied, the rectified mains voltage (VHV) is buffered by capacitor C2 and starts supplying the BD555BKFV via start-up resistor R6. The VDDH capacitor C5 will be charged by the internal regulator until the system UVLO condition is released, after which a PWM signal from terminal SW can start driving the external NMOS when the anti-flash detector is released.

Anti-flash detector: Some dimmers require a small leakage current to power an internal electronic control circuit or an indicator LED. In order to prevent a 'false start' when the VHV buffer cap was accidentally charged by this leakage current, the detection level voltage on the DIM terminal needs to rise above 400mV, before the SW terminal starts switching, lighting up the LEDs.

DC/DC buck converter: When the SW signal is high, it turns ON the MN2 MOSFET, building up a current in coil L1 via the LED string. During the OFF period of MN2, the current flows via fly-back diode D4. Capacitor C4 stabilizes the LED voltage to reduce the LED current ripple. The LED current is regulated by controlling the LED forward voltage.

Auxiliary supply voltage: The alternating current in the primary side of inductor L1 is coupled $n_p:n_s$ to the secondary side, creating a voltage alternating between V_{VHV} (MN2=ON) and $(V_{LED} + V_{th,D4}) * n_s/n_p$ (MN2=OFF). This last voltage is passed on to capacitor C3 via diode D5. This creates an auxiliary supply which improves efficiency by reducing the resistive power loss in the start-up resistor R6.

LED average current control (ACC) mode: The BD555BKFV features two feedback mechanisms by average current control (ACC) or peak current control (PCC). In ACC mode, the high-side sensing resistor R7 is used in the LED current mirror (typically 1:500), creating an LED feedback current in transistor Q1. This current flows to the FB terminal and creating a reference voltage (for LED current regulation) across resistor R12 at the REF terminal.

LED peak current control (PCC) mode: Alternatively, in PCC mode ($V_{FB} < 1.5V$), the duty-cycle of the SW signal is determined by the 'peak current' through resistor R10. The ISNS terminal senses the voltage across resistor R10. When this voltage reaches the reference voltage, the SW signal will be pulled low. During startup and in ACC mode, this function is used as 'Over Current Protection' to limit the current through inductor L1. In both ACC and PCC mode, the REF voltage will be adjusted to the detected phase-cut in case a dimmer is connected.

Phase-cut detection: via resistive divider R4/R5 at the DET terminal, the rising and falling edge of the phase-cut are detected, generating an internal PWM signal. Via an internal resistor and external capacitor C1, this PWM signal is averaged into a dimming reference voltage at the DIM terminal. An internal conversion function creates a logarithmically corrected voltage at the REF terminal. This allows achieving a 'natural' LED light intensity curve as perceived by the human eye, when turning the dimmer knob.

Dimmer stability: based on the phase-cut detection at the DET terminal, the DLCC dynamically adjusts the total load current for stable operation of 'leading edge' TRIAC dimmers. For 'trailing edge' dimmers, the DLCC load current pulls down the dimmer output voltage, in order to detect the falling edge. In case the VHV current exceeds the minimum load current requirement, the DLCC load current can be disabled completely. This allows to achieve high efficiency without dimmers.

Dimmer detector: when a dimmer is not present, the DLCC will be switched OFF.

● Absolute Maximum Ratings

Parameter	Symbol	Maximum rating	Unit
Supply voltage (SUP terminal)	V _{SUP}	40	V
Internal supply regulator voltage (VDDH terminal)	V _{VDDH}	15.5	V
SW output current	I _{SW}	600 ^{*1}	mA
BLDR output current	I _{BLDR}	60 ^{*1}	mA
WLBD, ISNS terminal voltage	V _{WLBD} , V _{ISNS}	15.5	V
WBLD input current (strong load current)	I _{SBLD}	300 ^{*2}	mA
DIM, DET, OSC, REF, FB terminal voltage	V _{DIM} , V _{DET} , V _{OSC} , V _{REF} , V _{FB}	4.5	V
FB input current (V _{FB} =4.5V)	I _{FB}	4.0	mA
ISYS, PGND terminal voltage	V _{ISYS} , V _{PGND}	+/- 0.5	V
Operating frequency	f _{operating}	400	kHz
Maximum power dissipation	P _d	0.87 ^{*4}	W
Operating ambient temperature range	T _a	-40 ~ +110	°C
Storage temperature range	T _{storage}	-55 ~ +150	°C
Maximum junction temperature	T _{junction,max}	+150	°C

*1 I_{SW} pulse current duration <100ns@f_{operating}
 *2 I_{BLDR} pulse current duration <1us@f_{mains}
 *3 I_{WBLD} pulse current duration <300us@f_{mains}

} never exceed 0.8*Pd

*4 SSOP-B14 package thermal resistance R_{θJA}=143°C/W, mounted on a two-layer PCB of 70x70x1.6mm³

Notice1: Due to in case of the applied voltage or operating ambient temperature range or etc. exceed the absolute maximum ratings, a damage maybe occurs, and the damage mode (short or open or etc.) can not be supposed, please take a physical safety measure (such as add a fuse) while some special modes in which the absolute maximum ratings may be exceeded are considered.

Notice2: The power dissipation in BD555BKFV is mainly decided by the switching frequency of the DCDC converter and the current which is applied to the BLDR pin. Please make the power dissipation caused by those less than 80% of the maximum power dissipation of the package.

● Recommended Operating Range (Ta= -40 ~ +110°C)

Parameter	Symbol	Range	Unit
Supply voltage	VSUP	16 ~ 39	V

● Electrical Characteristics

Parameter	Symbol	Limits			Unit	Comments
		Min.	Typ.	Max.		
Internal Supply Regulator*1						
Startup current	I _{SUP,start}	-	0.4	0.8	mA	In UVLO condition
Supply current ON	I _{SUP,NS}	-	0.8	1.0	mA	No switching.
Supply current ON 1	I _{SUP,ON1}	-	1.0	1.3	mA	No load on SW/BLDR, f _{SW} =40kHz.
Supply current ON 2	I _{SUP,ON2}	-	2	2.4	mA	No load on SW/BLDR, f _{SW} =400kHz.
VDDH internal regulator voltage	V _{VDDH}	10.0	11.5	15.0	V	VDDH load current I _{VDDH} < 10mA
UVLO release voltage	V _{UVLO,rl}	9.20	10.0	10.8	V	VDDH rising
UVLO trigger voltage	V _{UVLO,tr}	V _{UVLO,tr} - V _{UVLO,hys}			V	VDDH falling
UVLO hysteresis	V _{UVLO,hys}	0.75	1.00	1.25	V	
Switching regulator						
Minimum frequency	f _{SW,min}	32	40	48	kHz	f _{SW} = 9.0x10 ⁶ /R11 (kHz) ^{±20%} , for frequency range 40KHz to 400KHz.
Maximum frequency	f _{SW,max}	320	400	480	kHz	
SW maximum duty cycle	δ _{max}	70	75	80	%	

Parameter	Symbol	Limits			Unit	Comments
		Min.	Typ.	Max.		
SW minimum ON-time	$t_{ON,min}$	-	80	140	ns	Determines minimum duty-cycle
SW slew rate	$t_{SW,slew}$	-	50	100	ns	$V_{SW} = 1 \dots 11V$ at 1nF load (rising/falling)
SW driver ON resistance (PMOS)	$R_{SW,P}$	-	15	40	Ω	$V_{SW}=0V, I_{SW}=-10mA$
SW driver OFF resistance (NMOS)	$R_{SW,N}$	-	15	40	Ω	$V_{SW}=V_{DDH}, I_{SW}=10mA$
Duty cycle, FB=3.5V	δ_{20}	2	20	38	%	ACC mode
Duty cycle, FB=2.9V	δ_{60}	36	60	80	%	
FB mode selection threshold	$V_{FB,mode}$	1.4	1.6	1.9	V	PCC ($V_{FB}<1.4V$), ACC ($V_{FB}>1.9V$)
ISNS trigger voltage (OCP)	V_{OCP}	1.08	1.20	1.36	V	Inductor current limiter in ACC mode
ISNS blanking time (OCP)	$t_{OCP,blank}$	90	140	180	ns	Used in PCC & ACC mode
Dimmer phase-cut detector						
DET phase cut voltage (rising)	$V_{DET,r}$	215	260	300	mV	Monitored at output bridge rectifier
DET phase cut voltage (falling)	$V_{DET,f}$	75	110	190	mV	
DET phase cut hysteresis	$V_{DET,hys}$	75	130	180	mV	
DIM voltage (no dimming)	V_{DIM1}	2.85	3.0	3.15	V	Phase-cut = 135°
DIM voltage (max dimming)	V_{DIM2}	0.95	1.0	1.05	V	Phase-cut = 45°
REF voltage (no dimming) ACC	$V_{REF,A1}$	1.85	2.0	2.15	V	ACC mode ($V_{FB}>1.9$), $2k\Omega < R_{REF} < 10k\Omega$
REF voltage (max dimming) ACC	$V_{REF,A2}$	75	100	135	mV	
ISNS voltage (no dimming) PCC	$V_{ISNS,P1}$	1.12	1.24	1.36	V	PCC mode ($V_{FB} < 1.5V$). V_{ISNS} peak current threshold, $R_{REF}=2k\Omega$
ISNS voltage (max dimming) PCC	$V_{ISNS,P2}$	200	260	316	mV	
Dynamic Load Current Controller						
BLDR driver slew rate	$t_{BLDR,slew}$	-	1	5	us	$V_{SW} = 1 \dots 11V$ at 1nF load (rising/falling)
BLDR driver ON resistance	$R_{BLDR,P}$	-	100	300	Ω	$V_{BLDR}=0V, I_{BLDR}=-10mA$
BLDR driver OFF resistance	$R_{BLDR,N}$	-	100	300	Ω	$V_{BLDR}=V_{DDH}, I_{BLDR}=10mA$
Strong load current	$I_{SBLD,sat}$	200	250	-	mA	Strong load current ON ($V_{ISYS}<100mV$, $V_{DIM}<3.4V, V_{VDDH}=11.5V, V_{WBLD}-V_{ISYS}=8V$)
Strong load internal NMOS R_{ON}	$R_{ON,SBLD}$	-	10	300	Ω	Strong load current ON ($V_{ISYS}<100mV$, $V_{DIM}<3.4V, V_{VDDH}=11.5V, V_{WBLD}-V_{ISYS}=8V$)
Strong load current OFF delay	$t_{SB,OFF}$	180	250	320	μs	After phase-cut rising edge
Dimmer detector trigger voltage	$V_{DIM,tr}$	3.3	3.5	3.7	V	DLCC load current OFF
Dimmer detector release voltage	$V_{DIM,rl}$	$V_{DIM,tr}-V_{DIM,hys}$			V	DLCC load current ON
Dimmer detector hysteresis	$V_{DIM,hys}$	50	100	170	mV	
ISYS load current OFF voltage	$V_{ISYS,OFF}$	-260	-200	-160	mV	DLCC load current OFF
ISYS load current ON voltage	$V_{ISYS,ON}$	$V_{ISYS,OFF}+V_{ISYS,hys}$			mV	DLCC load current ON
ISYS current sense hysteresis	$V_{ISYS,hys}$	75	100	140	mV	
Anti-flash detector threshold	$V_{DIM,start}$	360	400	440	mV	DC/DC starts switching ($V_{DIM} > 400mV$)

*1 The supply regulator has a thermal shutdown function that triggers at about 175°C, having a hysteresis of about 20°C. This protects against a too high junction-temperature (e.g. due to 'short' currents of VDDH, SW or BLDR to (P)GND on the PCB or excessive ambient temperatures).

●Application Examples

The BD555BKFV is typically used as a controller IC in retro-fit dimmable LED lighting systems. The external component selection is fully dependent on the type of LED driver. For more information about this, please refer to the BD555BKFV application note. The example circuit below shows a dimmable non-isolated buck converter. A non-isolated topology is suitable for relatively low LED power (e.g. $V_{LED}=100V$ and $I_{LED}=40mA$) applications in which the LED heatsink is electrically isolated by a non-conductive LED lamp casing.

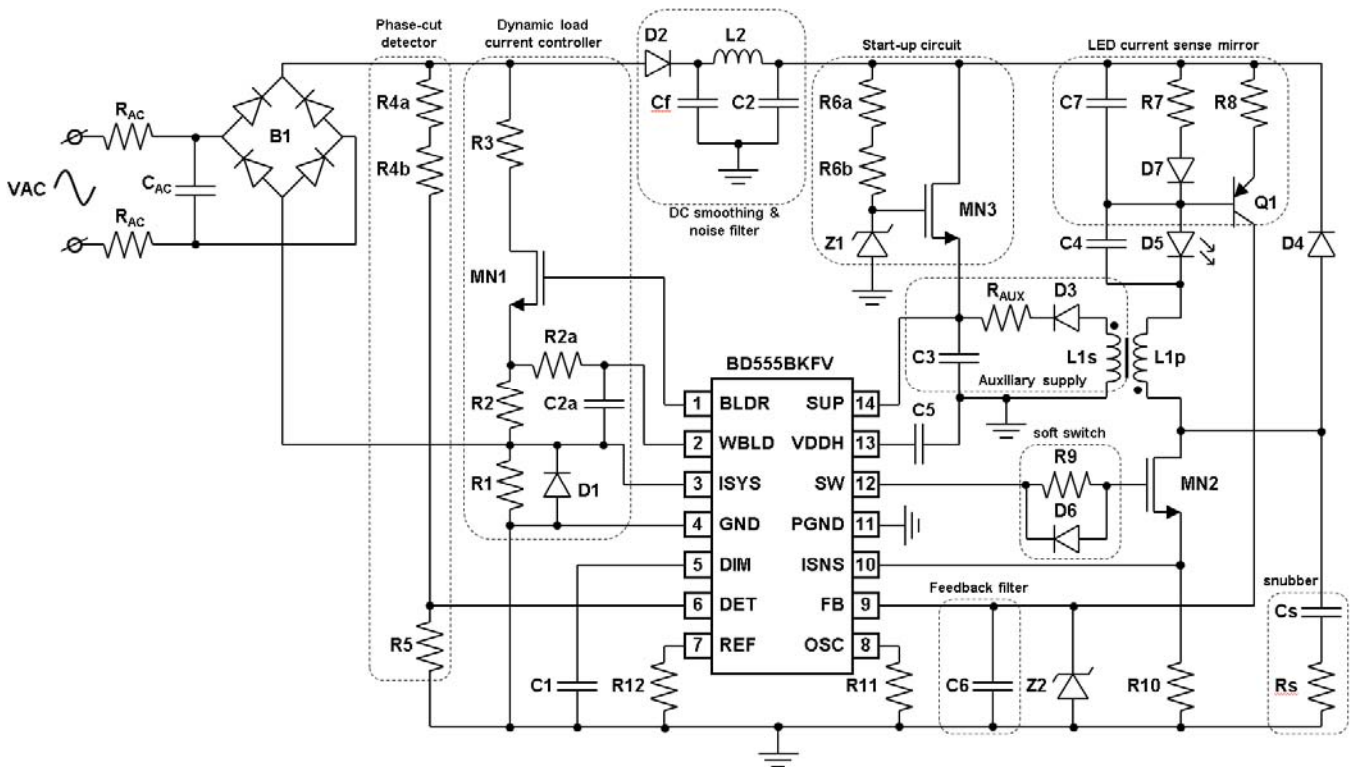

Figure 5. Final application circuit for non-isolated dimmable ACC LED driver

●Notes of Board Layout

There are a few considerations for designing a small-sized PCB that fits inside a LED lamp casing. Special attention needs to be given to component placement for optimal grounding and minimum distances of high-voltage wiring.

- 1) OCP sense resistor R_{OCP} and snubber resistor R_s need to be connected as close as possible to the minus terminal of the VHV buffer capacitor.
- 2) The drain terminal of switching NMOS MN2 should be close to the inductor L1p and fly-back diode D4.
- 3) The GND and PGND terminals need to be connected directly on the PCB.
- 4) For mains-isolated designs (not described in this document), the isolated PCB terminals need to be separated from the 'hot' side electronics.

●Selection of Components Externally Connected

Please refer to the BD555BKFV application note for more information about selecting the external components.

●Notes of Pin Connections

- a. Never connect FB pin to GND. It is suggested that pull down the FB pin to GND with a resistance over $10k\Omega$, while you want to use the PCC mode.
- b. In case of a dimmable LED driver application, please use a diode with a forward bias from ISYS pin to GND for protecting the ISYS pin when you want to sense the GND current. For a more stable operation, please add a capacitance over $1\mu F$ between ISYS pin and GND.
- c. Never connect capacitive loads to REF pin and OSC pin. Please connect resistive loads to these two pins.
- d. Always make the GND pin connecting with the PGND pin on the PCB. Especially, notice that please keep the GND pin away from the noise. And never apply a minus voltage to all pins except the ISYS pin.
- e. Never apply voltage to IC pins while the SUP pin is not applied with a voltage.

Operational Notes

1. Reverse Connection of Power Supply

Connecting the power supply in reverse polarity can damage the IC. Take precautions against reverse polarity when connecting the power supply, such as mounting an external diode between the power supply and the IC's power supply terminals.

2. Power Supply Lines

Design the PCB layout pattern to provide low impedance supply lines. Separate the ground and supply lines of the digital and analog blocks to prevent noise in the ground and supply lines of the digital block from affecting the analog block. Furthermore, connect a capacitor to ground at all power supply pins. Consider the effect of temperature and aging on the capacitance value when using electrolytic capacitors.

3. Ground Voltage

Ensure that no pins are at a voltage below that of the ground pin at any time, even during transient condition.

4. Ground Wiring Pattern

When using both small-signal and large-current ground traces, the two ground traces should be routed separately but connected to a single ground at the reference point of the application board to avoid fluctuations in the small-signal ground caused by large currents. Also ensure that the ground traces of external components do not cause variations on the ground voltage. The ground lines must be as short and thick as possible to reduce line impedance.

5. Thermal Consideration

Should by any chance the power dissipation rating be exceeded the rise in temperature of the chip may result in deterioration of the properties of the chip. The absolute maximum rating of the Pd stated in this specification is when the IC is mounted on a 70mm x 70mm x 1.6mm glass epoxy board. In case of exceeding this absolute maximum rating, increase the board size and copper area to prevent exceeding the Pd rating.

6. Recommended Operating Conditions

These conditions represent a range within which the expected characteristics of the IC can be approximately obtained. The electrical characteristics are guaranteed under the conditions of each parameter.

7. Rush Current

When power is first supplied to the IC, it is possible that the internal logic may be unstable and inrush current may flow instantaneously due to the internal powering sequence and delays, especially if the IC has more than one power supply. Therefore, give special consideration to power coupling capacitance, power wiring, width of ground wiring, and routing of connections.

8. Operation Under Strong Electromagnetic Field

Operating the IC in the presence of a strong electromagnetic field may cause the IC to malfunction.

9. Testing on Application Boards

When testing the IC on an application board, connecting a capacitor directly to a low-impedance output pin may subject the IC to stress. Always discharge capacitors completely after each process or step. The IC's power supply should always be turned off completely before connecting or removing it from the test setup during the inspection process. To prevent damage from static discharge, ground the IC during assembly and use similar precautions during transport and storage.

10. Inter-pin Short and Mounting Errors

Ensure that the direction and position are correct when mounting the IC on the PCB. Incorrect mounting may result in damaging the IC. Avoid nearby pins being shorted to each other especially to ground, power supply and output pin. Inter-pin shorts could be due to many reasons such as metal particles, water droplets (in very humid environment) and unintentional solder bridge deposited in between pins during assembly to name a few.

Operational Notes – continued

11. Unused Input Terminals

Input terminals of an IC are often connected to the gate of a MOS transistor. The gate has extremely high impedance and extremely low capacitance. If left unconnected, the electric field from the outside can easily charge it. The small charge acquired in this way is enough to produce a significant effect on the conduction through the transistor and cause unexpected operation of the IC. So unless otherwise specified, unused input terminals should be connected to the power supply or ground line.

12. Regarding the Input Pin of the IC

This monolithic IC contains P+ isolation and P substrate layers between adjacent elements in order to keep them isolated. P-N junctions are formed at the intersection of the P layers with the N layers of other elements, creating a parasitic diode or transistor. For example (refer to figure below):

When $GND > Pin A$ and $GND > Pin B$, the P-N junction operates as a parasitic diode.
When $GND > Pin B$, the P-N junction operates as a parasitic transistor.

Parasitic diodes inevitably occur in the structure of the IC. The operation of parasitic diodes can result in mutual interference among circuits, operational faults, or physical damage. Therefore, conditions that cause these diodes to operate, such as applying a voltage lower than the GND voltage to an input pin (and thus to the P substrate) should be avoided.

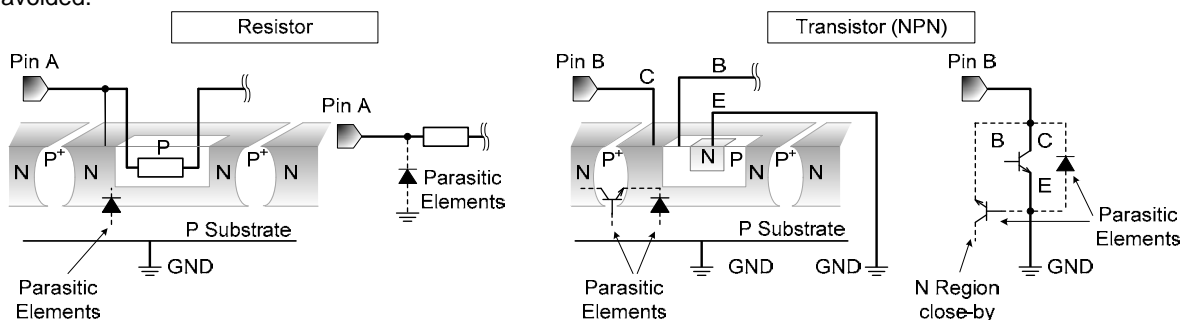

Figure xx. Example of monolithic IC structure

13. Ceramic Capacitor

When using a ceramic capacitor, determine the dielectric constant considering the change of capacitance with temperature and the decrease in nominal capacitance due to DC bias and others.

14. Area of Safe Operation (ASO)

Operate the IC such that the output voltage, output current, and power dissipation are all within the Area of Safe Operation (ASO).

15. Thermal Shutdown Circuit(TSD)

This IC has a built-in thermal shutdown circuit that prevents heat damage to the IC. Normal operation should always be within the IC's power dissipation rating. If however the rating is exceeded for a continued period, the junction temperature (T_j) will rise which will activate the TSD circuit that will turn OFF all output pins. When the T_j falls below the TSD threshold, the circuits are automatically restored to normal operation.

Note that the TSD circuit operates in a situation that exceeds the absolute maximum ratings and therefore, under no circumstances, should the TSD circuit be used in a set design or for any purpose other than protecting the IC from heat damage.

16. Over Current Protection Circuit (OCP)

This IC incorporates an integrated overcurrent protection circuit that is activated when the load is shorted. This protection circuit is effective in preventing damage due to sudden and unexpected incidents. However, the IC should not be used in applications characterized by continuous operation or transitioning of the protection circuit.

●Ordering Information

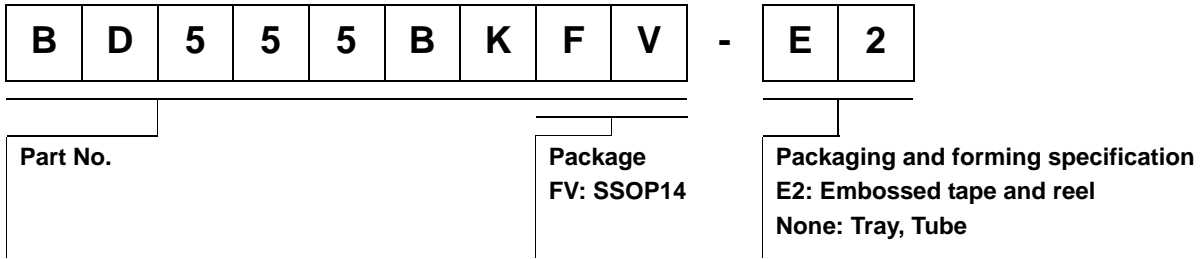

●Marking Diagram (TOP VIEW)

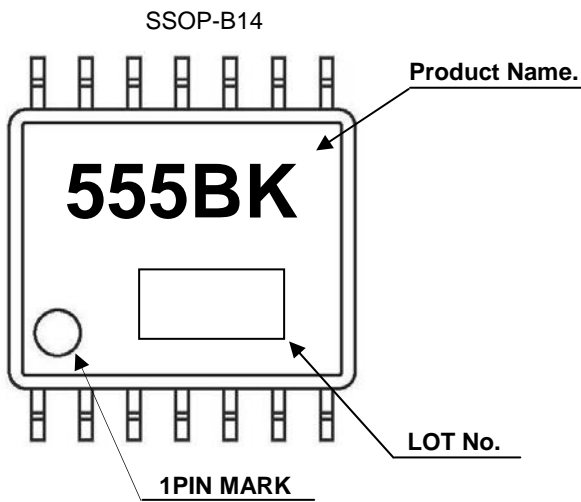

●Physical Dimension, Tape and Reel Information

Package Name	SSOP-B14
---------------------	-----------------

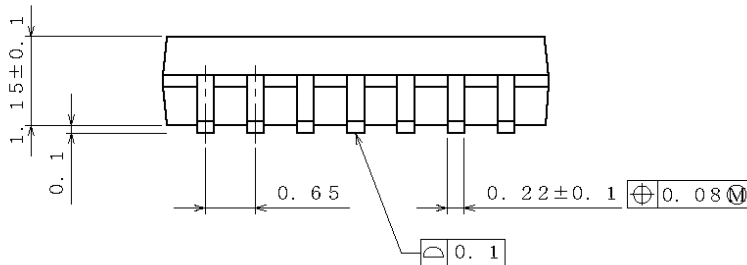
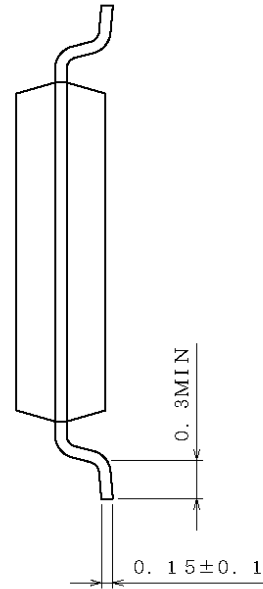
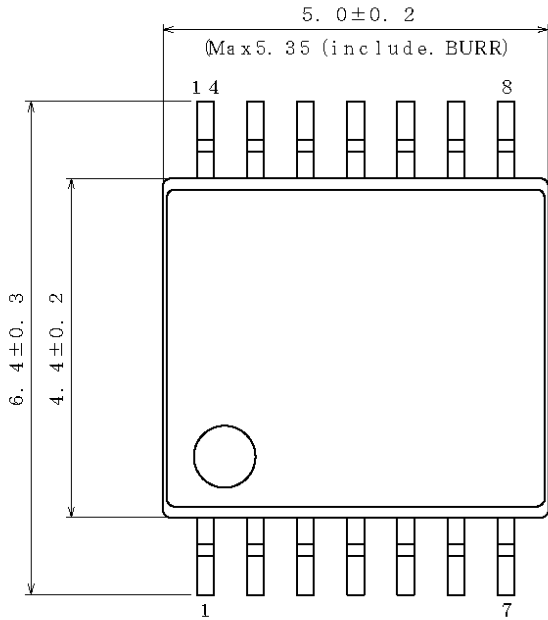

(UNIT : mm)
 PKG : SSOP-B14
 Drawing No. EX152-5002

<Tape and Reel information>

Tape	Embossed carrier tape
Quantity	2500pcs
Direction of feed	E2 (The direction is the 1pin of product is at the upper left when you hold reel on the left hand and you pull out the tape on the right hand)

Reel 1pin Direction of feed
 *Order quantity needs to be multiple of the minimum quantity.

●Revision History

Date	Revision	Changes
29.May.2012	001	New Release
19.July.2013	002	Revision Update
30.July.2013	003	p.2 ·Add "I/O" column to "Pin Description". p.5 ·Add "Notice1" and "Notice2" to "Absolute Maximum Ratings". p.7 ·Delete the descriptions for "Power Dissipation". ·Add the descriptions for "Notes of Pins Connections". p.13, p.14 ·Add "Notice".

Notice

Precaution on using ROHM Products

- Our Products are designed and manufactured for application in ordinary electronic equipments (such as AV equipment, OA equipment, telecommunication equipment, home electronic appliances, amusement equipment, etc.). If you intend to use our Products in devices requiring extremely high reliability (such as medical equipment ^(Note 1), transport equipment, traffic equipment, aircraft/spacecraft, nuclear power controllers, fuel controllers, car equipment including car accessories, safety devices, etc.) and whose malfunction or failure may cause loss of human life, bodily injury or serious damage to property ("Specific Applications"), please consult with the ROHM sales representative in advance. Unless otherwise agreed in writing by ROHM in advance, ROHM shall not be in any way responsible or liable for any damages, expenses or losses incurred by you or third parties arising from the use of any ROHM's Products for Specific Applications.

(Note1) Medical Equipment Classification of the Specific Applications

JAPAN	USA	EU	CHINA
CLASS III	CLASS III	CLASS II b	CLASS III
CLASS IV		CLASS III	

- ROHM designs and manufactures its Products subject to strict quality control system. However, semiconductor products can fail or malfunction at a certain rate. Please be sure to implement, at your own responsibilities, adequate safety measures including but not limited to fail-safe design against the physical injury, damage to any property, which a failure or malfunction of our Products may cause. The following are examples of safety measures:
 - Installation of protection circuits or other protective devices to improve system safety
 - Installation of redundant circuits to reduce the impact of single or multiple circuit failure
- Our Products are designed and manufactured for use under standard conditions and not under any special or extraordinary environments or conditions, as exemplified below. Accordingly, ROHM shall not be in any way responsible or liable for any damages, expenses or losses arising from the use of any ROHM's Products under any special or extraordinary environments or conditions. If you intend to use our Products under any special or extraordinary environments or conditions (as exemplified below), your independent verification and confirmation of product performance, reliability, etc. prior to use, must be necessary:
 - Use of our Products in any types of liquid, including water, oils, chemicals, and organic solvents
 - Use of our Products outdoors or in places where the Products are exposed to direct sunlight or dust
 - Use of our Products in places where the Products are exposed to sea wind or corrosive gases, including Cl₂, H₂S, NH₃, SO₂, and NO₂
 - Use of our Products in places where the Products are exposed to static electricity or electromagnetic waves
 - Use of our Products in proximity to heat-producing components, plastic cords, or other flammable items
 - Sealing or coating our Products with resin or other coating materials
 - Use of our Products without cleaning residue of flux (even if you use no-clean type fluxes, cleaning residue of flux is recommended); or Washing our Products by using water or water-soluble cleaning agents for cleaning residue after soldering
 - Use of the Products in places subject to dew condensation
- The Products are not subject to radiation-proof design.
- Please verify and confirm characteristics of the final or mounted products in using the Products.
- In particular, if a transient load (a large amount of load applied in a short period of time, such as pulse. is applied, confirmation of performance characteristics after on-board mounting is strongly recommended. Avoid applying power exceeding normal rated power; exceeding the power rating under steady-state loading condition may negatively affect product performance and reliability.
- De-rate Power Dissipation (Pd) depending on Ambient temperature (Ta). When used in sealed area, confirm the actual ambient temperature.
- Confirm that operation temperature is within the specified range described in the product specification.
- ROHM shall not be in any way responsible or liable for failure induced under deviant condition from what is defined in this document.

Precaution for Mounting / Circuit board design

- When a highly active halogenous (chlorine, bromine, etc.) flux is used, the residue of flux may negatively affect product performance and reliability.
- In principle, the reflow soldering method must be used; if flow soldering method is preferred, please consult with the ROHM representative in advance.

For details, please refer to ROHM Mounting specification

Precautions Regarding Application Examples and External Circuits

1. If change is made to the constant of an external circuit, please allow a sufficient margin considering variations of the characteristics of the Products and external components, including transient characteristics, as well as static characteristics.
2. You agree that application notes, reference designs, and associated data and information contained in this document are presented only as guidance for Products use. Therefore, in case you use such information, you are solely responsible for it and you must exercise your own independent verification and judgment in the use of such information contained in this document. ROHM shall not be in any way responsible or liable for any damages, expenses or losses incurred by you or third parties arising from the use of such information.

Precaution for Electrostatic

This Product is electrostatic sensitive product, which may be damaged due to electrostatic discharge. Please take proper caution in your manufacturing process and storage so that voltage exceeding the Products maximum rating will not be applied to Products. Please take special care under dry condition (e.g. Grounding of human body / equipment / solder iron, isolation from charged objects, setting of Ionizer, friction prevention and temperature / humidity control).

Precaution for Storage / Transportation

1. Product performance and soldered connections may deteriorate if the Products are stored in the places where:
 - [a] the Products are exposed to sea winds or corrosive gases, including Cl₂, H₂S, NH₃, SO₂, and NO₂
 - [b] the temperature or humidity exceeds those recommended by ROHM
 - [c] the Products are exposed to direct sunshine or condensation
 - [d] the Products are exposed to high Electrostatic
2. Even under ROHM recommended storage condition, solderability of products out of recommended storage time period may be degraded. It is strongly recommended to confirm solderability before using Products of which storage time is exceeding the recommended storage time period.
3. Store / transport cartons in the correct direction, which is indicated on a carton with a symbol. Otherwise bent leads may occur due to excessive stress applied when dropping of a carton.
4. Use Products within the specified time after opening a humidity barrier bag. Baking is required before using Products of which storage time is exceeding the recommended storage time period.

Precaution for Product Label

QR code printed on ROHM Products label is for ROHM's internal use only.

Precaution for Disposition

When disposing Products please dispose them properly using an authorized industry waste company.

Precaution for Foreign Exchange and Foreign Trade act

Since our Products might fall under controlled goods prescribed by the applicable foreign exchange and foreign trade act, please consult with ROHM representative in case of export.

Precaution Regarding Intellectual Property Rights

1. All information and data including but not limited to application example contained in this document is for reference only. ROHM does not warrant that foregoing information or data will not infringe any intellectual property rights or any other rights of any third party regarding such information or data. ROHM shall not be in any way responsible or liable for infringement of any intellectual property rights or other damages arising from use of such information or data.:
2. No license, expressly or implied, is granted hereby under any intellectual property rights or other rights of ROHM or any third parties with respect to the information contained in this document.

Other Precaution

1. This document may not be reprinted or reproduced, in whole or in part, without prior written consent of ROHM.
2. The Products may not be disassembled, converted, modified, reproduced or otherwise changed without prior written consent of ROHM.
3. In no event shall you use in any way whatsoever the Products and the related technical information contained in the Products or this document for any military purposes, including but not limited to, the development of mass-destruction weapons.
4. The proper names of companies or products described in this document are trademarks or registered trademarks of ROHM, its affiliated companies or third parties.

General Precaution

1. Before you use our Products, you are requested to carefully read this document and fully understand its contents. ROHM shall not be in any way responsible or liable for failure, malfunction or accident arising from the use of any ROHM's Products against warning, caution or note contained in this document.
2. All information contained in this document is current as of the issuing date and subject to change without any prior notice. Before purchasing or using ROHM's Products, please confirm the latest information with a ROHM sales representative.
3. The information contained in this document is provided on an "as is" basis and ROHM does not warrant that all information contained in this document is accurate and/or error-free. ROHM shall not be in any way responsible or liable for any damages, expenses or losses incurred by you or third parties resulting from inaccuracy or errors of or concerning such information.