

SPECIFICATIONS

Material: APM RUBGLAS™ (transparent silicone rubber), polymer type, ASTM D1418.

Temperature Range: -80°F to +400°F

Operational Life: 50,000 actuations (minimum).

Shelf Life: Excess of 25 years.

Resistant to: Salt spray, sunlight, ozone, weather, fungus, and most acids and lubricating oils

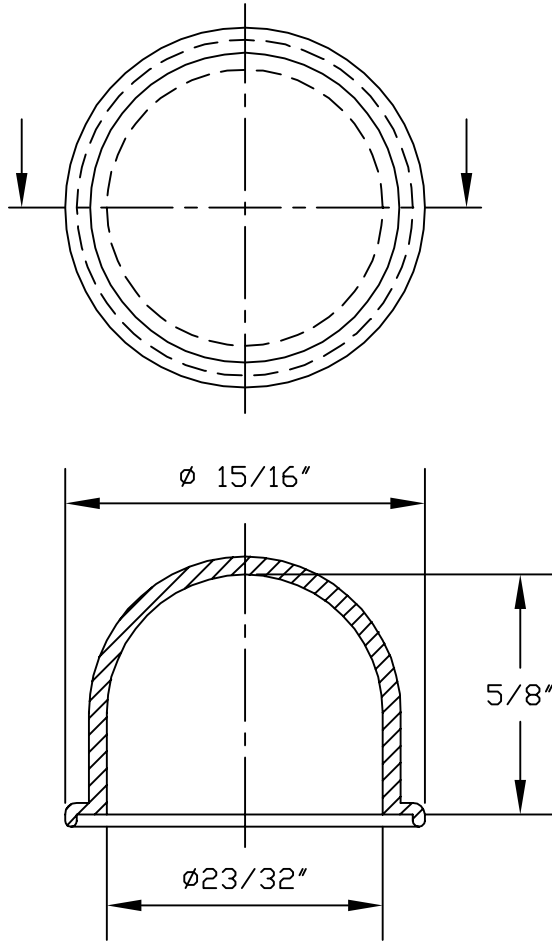

ALL DIMENSIONS HAS $\pm 1/32$ TOLERANCE

A				CAD COMPUTER GENERATED, ADDED TOLERANCE		S. GOK		08.18.08	
REV.		DESCRIPTION						DATE	
MAXIMUM AND MINIMUM MEASUREMENTS ARE STATED DIRECTLY ON EACH DIMENSION.		TITLE:		SEEL - KAP		ENG.		08.18.08	
						S. GOK			
MAT'L: RUBGLAS®		APM-HEXSEAL CORPORATION		DWN.		M.M.		10.12.75	
				CHKD.		J. CELLA		08.18.08	
FINISH: CLEAR				SCALE		DWG. NO.		1213/44	
				2 : 1					

THIS DRAWING COVERS PROPRIETARY ITEM AND IS THE PROPERTY OF THE APM-HEXSEAL CORPORATION.
THIS DRAWING IS NOT TO BE COPIED OR USED WITHOUT THE WRITTEN APPROVAL OF AN OFFICER OF THE APM-HEXSEAL CORPORATION.