

SGD ADPT-TC

Thermocouple conditioning module for PanelPilot-compatible displays

ORDERING INFORMATION

SGD-TC add-on board (Add-on board & K-type thermocouple probe)	SGD ADPT-TC
PanelPilot-compatible displays - see PanelPilot.com	SGD 24-M SGD 28-M SGD 35-M

FEATURES

- -200 to +1350 °C (-328 to +2462 °F) K-type measurement range
- -200 to +1190 °C (-328 to +2174 °F) J-type measurement range
- -200 to +390 °C (-328 to +734 °F) T-type measurement range
- Powered from SGD meter
- Application download from PanelPilot website
- User selection of thermocouple type from PC software
- Pre-settable high and low alarms
- Display in either °C or °F

This add-on module interfaces directly with any PanelPilot-compatible display. It has built-in cold-junction compensation (CJC) and takes it's power directly from the SGD meter.



SGD 24-M not included

SPECIFICATIONS

Specifications	Minimum	Typical	Maximum	Unit
Probe Measurement range (K-type)	-200 (-328)		+1350 (+2462)	°C (°F)
Probe Measurement range (J-type)	-200 (-328)		+1190 (+2174)	°C (°F)
Probe Measurement range (T-type)	-200 (-328)		+390 (+734)	°C (°F)
Operating temperature range *	-10 (+14)		+40 (+104)	°C (°F)
Resolution (internal and displayed)		0.1 (0.1)		°C (°F)
Accuracy		±1 (±2)**		°C (°F)

* Operating temperature applies to the module only. Please consult the probe manufacturer for operating temperature of thermocouple.

** Quoted accuracy is for the module only and excludes the thermocouple probe. Thermocouple error should also be taken into consideration.

HARDWARE

The SGD-TC board takes it's power from the host SGD. Connect the 14-way connector IDC socket to the SGD, as shown below. The thermocouple is wired to the TC+ (green) and TC- (white) via the screw terminal block.



The system can be powered via the USB port at the SGD.



www.lascarelectronics.com



SGD ADPT-TC

Thermocouple conditioning module
for PanelPilot-compatible displays

TERMINAL CONNECTIONS

Terminal connection	Description
V+	Alternative power supply input for the SGD. This passes straight to the SGD via the ribbon cable. Do not use if the power is applied directly to the V+ terminal of the SGD.
0V	Ground connection for the SGD and TC board. Connection not necessary if alarm outputs not used.
ALM1	Open-collector alarm outputs of the SGD. See the SGD data sheet for full details.
ALM2	
TC+	Positive connection for the thermocouple (Green)
TC-	Negative connection for the thermocouple (White)

MOUNTING THE SGD-TC

The SGD-TC should be mounted separately from the SGD display module using the two mounting holes. Take care to observe correct polarity when connecting the power supply and the thermocouple.

Please refer to the SGD data sheet for instructions on mounting the SGD to a panel.

DIMENSIONS

All dimensions in mm

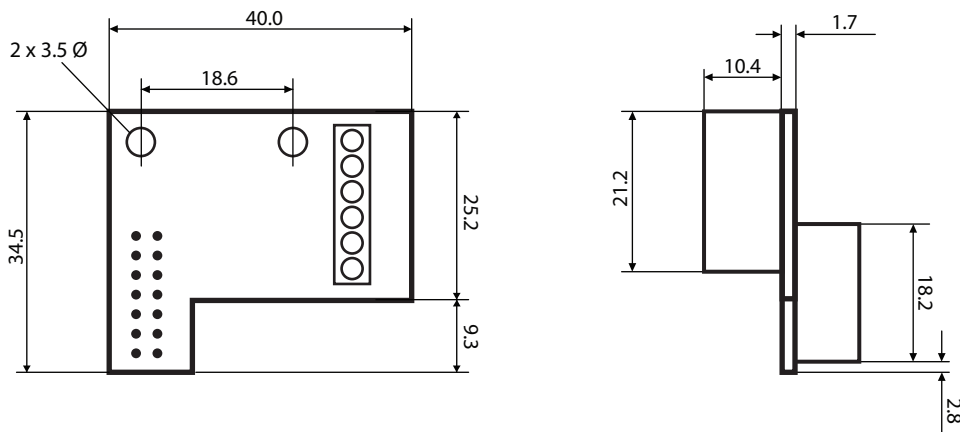

Module House
Whiteparish, Salisbury
Wiltshire SP5 2SJ
UK
T +44 (1794) 884567
F +44 (1794) 884616
E sales@lascar.co.uk

4258 West 12th Street
Erie
PA 16505
USA
T +1 (814) 835 0621
F +1 (814) 838 8141
E us-sales@lascarelectronics.com

8th Floor, China Aerospace Centre
143 Hoi Bun Road
Kwun Tong, Kowloon
HONG KONG
T +852 2389 6502
F +852 2389 6535
E saleshk@lascar.com.hk



www.lascarelectronics.com

