

Atmel PROTO1 Xplained Pro

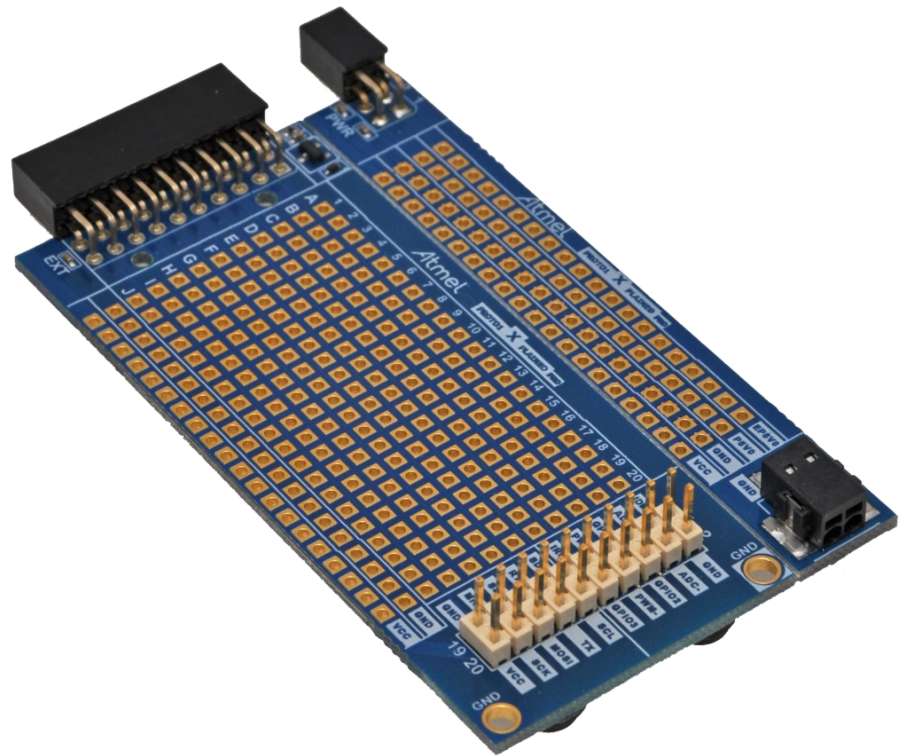

Preface

The Atmel® PROTO1 Xplained Pro extension board is a development board that can be used to prototype small circuits and easy connect it to Xplained Pro MCU boards through one of the standard extension headers. It includes an ID chip and will be recognized by Atmel Studio. It can also be used to interface older Xplained top-modules like sensor boards. There is a separate connector available to connect external power to a Xplained Pro series evaluation kits. This section can be separated from the prototype section to be used standalone or not at all.

Table of Contents

Preface	1
1. Introduction	3
1.1. Features	3
1.2. Kit Overview	3
2. Getting Started	5
2.1. Three Steps to Start Exploring the Atmel Xplained Pro Platform	5
2.2. Connecting PROTO1 Xplained Pro to the Xplained Pro MCU Board.	5
2.3. Documentation for Atmel PROTO1 Xplained Pro	5
3. Xplained Pro	6
3.1. Hardware Identification System	6
3.2. Standard Headers and Connectors	6
3.2.1. Xplained Pro Standard Extension Header	6
3.2.2. Power header	7
4. Hardware user guide	8
4.1. Connectors	8
4.1.1. PROTO1 Xplained Pro Extension Headers	8
4.1.2. Power Header	8
4.1.3. External Power Terminal Block Header	8
4.2. PROTO1 Xplained Pro ID System	9
4.3. Connecting the PROTO1 Xplained Pro	10
4.3.1. Connecting Xplained Extension Boards	11
4.3.2. Using PROTO1 Xplained Pro With a Solderless Breadboard	11
5. Hardware Revision History and Known Issues	13
5.1. Identifying Product ID and Revision	13
5.2. Revision 2	13
6. Document revision history	14
7. Evaluation board/kit important notice	15

1. Introduction

1.1 Features

- Prototyping area with 10 x 20 = 200 PADS
 - 100mil spacing to ease through-hole component prototyping
 - Square PADS to ease SMD passive component prototyping
 - Fits mini solderless breadboards for fast and simple prototyping
- Xplained Pro hardware identification system
- Can be used as an vertical extender for Xplained Pro standard extension modules
- Support for Xplained series extension modules

1.2 Kit Overview

The Atmel PROTO1 Xplained Pro board is a generic prototyping extension board for the Xplained Pro platform. It connects to any standard extension header on any Xplained Pro MCU board and thus offers an easy way to do prototyping with the Xplained Pro platform. It can be used to prototype small designs that can be connected to the Xplained Pro MCU series of kits. The prototype area consists of 200 free square pads with 100mil (2.54mm) spacing that can be used to prototype both through-hole components as well as SMD components like resistors, capacitors, inductors... The prototyping area is marked with letters and numbers on both sides of the board so it is easy to identify each pad with a coordinate to make precise connections. Power in the form of GND and VCC_TARGET (is distributed horizontally along the lower side of the prototype for easy connection across the board. The prototyping area offers also space to fit a solderless breadboard on top. A popular size of these boards is 45mm x 35mm and provides 170 solderless points.

The top section of the board is a break-away section that can be used to connect external power to the Xplained Pro MCU board with a screw terminal block. It also distributes GND, VCC_TARGET, and VCC_USB (+5V) from the Xplained Pro MCU board that can easily be connected to the prototyping area.

The lower section of the board has a right angled header on the left side that connects to Xplained Pro MCU boards, a prototyping area in the middle and another connector on the right side that provides easy access to the extension header signals. The vertical header on the right hand side can be used to connect the extension signals to the prototyping area or to connect extension modules of the Xplained platform e.g. sensor boards, or the RZ600 radio kit. More information on how to connect Xplained extensions is available in the hardware users guide section of this guide.

The Atmel PROTO1 Xplained Pro supports the Xplained Pro hardware identification system.

Figure 1-1. PROTO1 Xplained Pro Extension Board, Top View.

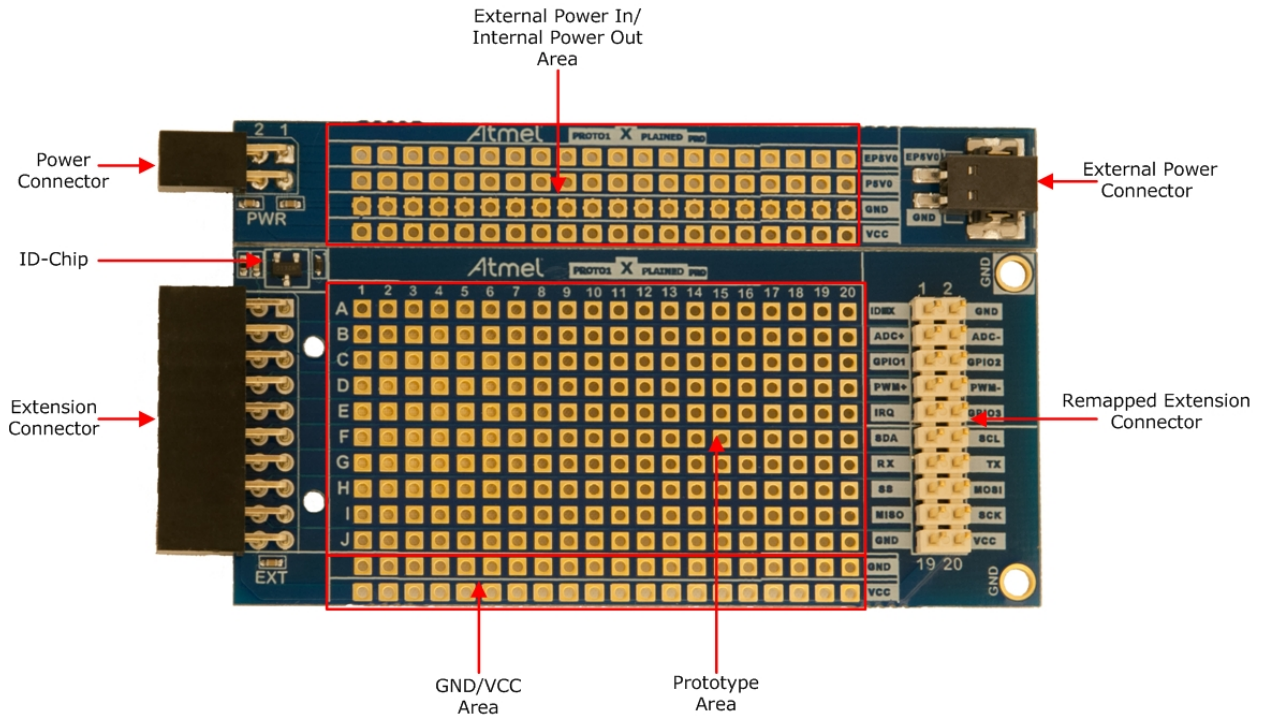
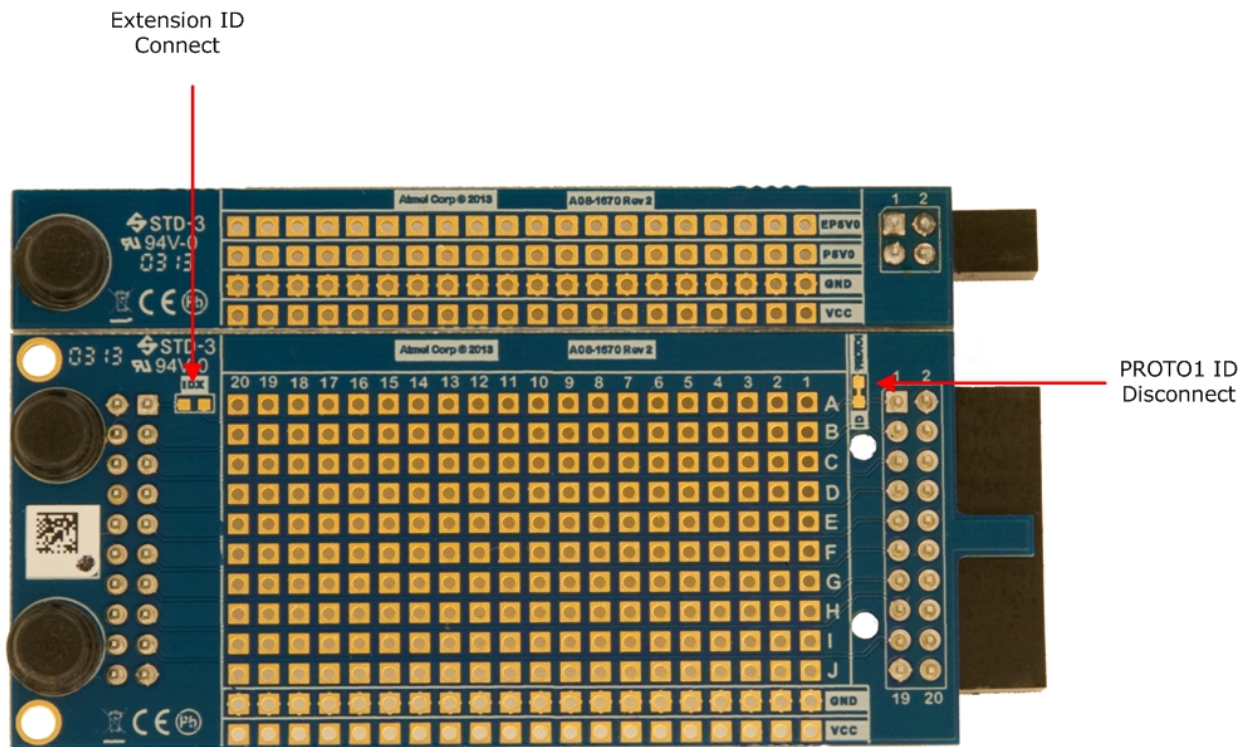

Figure 1-2. PROTO1 Xplained Pro Extension Board, Bottom View.



2. Getting Started

2.1 Three Steps to Start Exploring the Atmel Xplained Pro Platform

1. Download and install [Atmel Studio](#).
2. Launch Atmel Studio.
3. Connect PROTO1 Xplained Pro to an Xplained Pro MCU board and connect a USB cable to DEBUG USB port on the Xplained Pro MCU board.

2.2 Connecting PROTO1 Xplained Pro to the Xplained Pro MCU Board.

To start using the PROTO1 Xplained Pro extension board you will need an Xplained Pro MCU board with at least one standard 20-pin extension header. The PROTO1 Xplained Pro can be connected to any of these extension headers. After the PROTO1 Xplained Pro has been connected to an extension header the Xplained Pro MCU board can be powered in the normal way as described in the help for this kit.

Warning

If any modifications are done to the PROTO1 Xplained Pro prototype circuit, please check that there are no short-circuits on the power lines before connecting it to the Xplained Pro MCU board in order to avoid any damage.

2.3 Documentation for Atmel PROTO1 Xplained Pro

The following list contains links to the most relevant documents and software for the PROTO1 Xplained Pro.

1. [Xplained Pro products](#)¹ - Atmel Xplained Pro is a series of small-sized and easy-to-use evaluation kits for 8- and 32-bit Atmel microcontrollers. It consists of a series of low cost MCU boards for evaluation and demonstration of features and capabilities of different MCU families.
2. [PROTO1 Xplained Pro User Guide](#)² - PDF version of this User Guide.
3. [PROTO1 Xplained Pro Design Documentation](#)³ - Package containing schematics, BOM, assembly drawings, 3D plots, layer plots etc.
4. [Atmel Studio](#)⁴ - Free Atmel IDE for development of C/C++ and assembler code for Atmel microcontrollers.

¹ <http://www.atmel.com/XplainedPro>

² http://www.atmel.com/Images/Atmel-42080-PROTO1-Xplained-Pro_User-Guide.pdf

³ http://www.atmel.com/Images/Atmel-42080-PROTO1-Xplained-Pro_User-Guide.zip

⁴ <http://www.atmel.com/atmelstudio>

3. Xplained Pro

Xplained Pro is an evaluation platform that provides the full Atmel microcontroller experience. The platform consists of a series of Microcontroller (MCU) boards and extension boards that are integrated with Atmel Studio, have Atmel Software Framework (ASF) drivers and demo code, support data streaming and more. Xplained Pro MCU boards support a wide range of Xplained Pro extension boards that are connected through a set of standardized headers and connectors. Each extension board has an identification (ID) chip to uniquely identify which boards are mounted on a Xplained Pro MCU board. This information is used to present relevant user guides, application notes, datasheets and example code through Atmel Studio. Available Xplained Pro MCU and extension boards can be purchased in the [Atmel Web Store](http://store.atmel.com/)¹.

3.1 Hardware Identification System

All Xplained Pro compatible extension boards have an Atmel ATSHA204 CryptoAuthentication™ chip mounted. This chip contains information that identifies the extension with its name and some extra data. When an Xplained Pro extension board is connected to an Xplained Pro MCU board the information is read and sent to Atmel Studio. The Atmel Kits extension, installed with Atmel Studio, will give relevant information, code examples and links to relevant documents. [Table 3-1, “Xplained Pro ID Chip Content” on page 6](#) shows the data fields stored in the ID chip with example content.

Table 3-1. Xplained Pro ID Chip Content

Data Field	Data Type	Example Content
Manufacturer	ASCII string	Atmel'\0'
Product Name	ASCII string	Segment LCD1 Xplained Pro'\0'
Product Revision	ASCII string	02'\0'
Product Serial Number	ASCII string	1774020200000010'\0'
Minimum Voltage [mV]	uint16_t	3000
Maximum Voltage [mV]	uint16_t	3600
Maximum Current [mA]	uint16_t	30

3.2 Standard Headers and Connectors

3.2.1 Xplained Pro Standard Extension Header

All Xplained Pro kits have one or more dual row, 20-pin, 100mil extension headers. Xplained Pro MCU boards have male headers while Xplained Pro extensions have their female counterparts. Note that all pins are not always connected. However, all the connected pins follow the defined pin-out described in [Table 3-2, “Xplained Pro Extension Header” on page 6](#). The extension headers can be used to connect a wide variety of Xplained Pro extensions to Xplained Pro MCU boards and to access the pins of the target MCU on Xplained Pro MCU board directly.

Table 3-2. Xplained Pro Extension Header

Pin number	Name	Description
1	ID	Communication line to the ID chip on extension board.
2	GND	Ground.
3	ADC(+)	Analog to digital converter , alternatively positive part of differential ADC.
4	ADC(-)	Analog to digital converter , alternatively negative part of differential ADC.
5	GPIO1	General purpose I/O.
6	GPIO2	General purpose I/O.
7	PWM(+)	Pulse width modulation , alternatively positive part of differential PWM.
8	PWM(-)	Pulse width modulation , alternatively positive part of differential PWM.

¹ <http://store.atmel.com/>

Pin number	Name	Description
9	IRQ/GPIO	Interrupt request line and/or general purpose I/O.
10	SPI_SS_B/GPIO	Slave select for SPI and/or general purpose I/O.
11	TWI_SDA	Data line for two-wire interface. Always implemented, bus type.
12	TWI_SCL	Clock line for two-wire interface. Always implemented, bus type.
13	USART_RX	Receiver line of Universal Synchronous and Asynchronous serial Receiver and Transmitter.
14	USART_TX	Transmitter line of Universal Synchronous and Asynchronous serial Receiver and Transmitter.
15	SPI_SS_A	Slave select for SPI. Should be unique if possible.
16	SPI_MOSI	Master out slave in line of Serial peripheral interface. Always implemented, bus type.
17	SPI_MISO	Master in slave out line of Serial peripheral interface. Always implemented, bus type.
18	SPI_SCK	Clock for Serial peripheral interface. Always implemented, bus type.
19	GND	Ground.
20	VCC	Power for extension board.

3.2.2 Power header

The right-angled female power header (marked PWR) will connect to a similar header if the PROTO1 Xplained Pro is connected to the EXT1 extension header on the the Xplained Pro MCU board. It can be used to power the Xplained Pro MCU board from an external source or to get internal power from the Xplaiend Pro MCU board to the PROTO1 Xplained Pro

4. Hardware user guide

4.1 Connectors

This chapter describes the implementation of the relevant connectors and headers on PROTO1 Xplained Pro and their connection to the external devices. The tables of connections in this chapter also describes which signals are shared between the headers and on-board functionality.

4.1.1 PROTO1 Xplained Pro Extension Headers

The PROTO1 Xplained Pro has two 20-pin headers. One is angled (left side of the board) and is intended to be connected to a Xplained Pro MCU board, standard extension header. The other is a vertical header (right side of the board) that can be used to connect signals to the prototype area or to attach other extension modules to it. The signals are identical on both, except for the ID signal, which is slightly different. The rest of the signals follow the standard extension header pinout specified in [Xplained Pro Standard Extension Header on page 6](#). The different ID signals are described in section “[PROTO1 Xplained Pro ID System](#)” on page 9.

Figure 4-1. Extension Header Connector.



4.1.2 Power Header

The four pin power header on the PROTO1 Xplained Pro extension board is used to probe the voltage on the board. The pins of the header are marked in silk screen with VCC for target voltage and GND for ground.

Note

The two pin power header should not be used to apply power to the PROTO1 Xplained Pro. The board will get power from the Xplained Pro MCU board through the 20-pin extension connector.

Table 4-1. Power Header.

Silk screen marking	Description
VCC	Target voltage, main voltage of the PROTO1 Xplained Pro extension board
GND	Ground
EP5V0	External 5.0V supplied to the Xplained Pro MCU board
VP5V0	VCC_USB,

4.1.3 External Power Terminal Block Header

The PROTO1 Xplained Pro features a two pin terminal block header to connect external power to the board. To connect a cable to it, just insert it (remove the insulation from the end first) through the holes at the bottom

entry of the connector. An internal springblade will lock the wire in place. To release it again, insert a small screwdriver or similar into the top hole to release the tension of the springblade and pull the wire out. This is shown in [Table 4-3, “Power Connector.” on page 9](#).

Table 4-2. Power Connector.

Silk screen marking	Pin on Power connector
EP5V0	1
GND	2

Table 4-3. Power Connector.

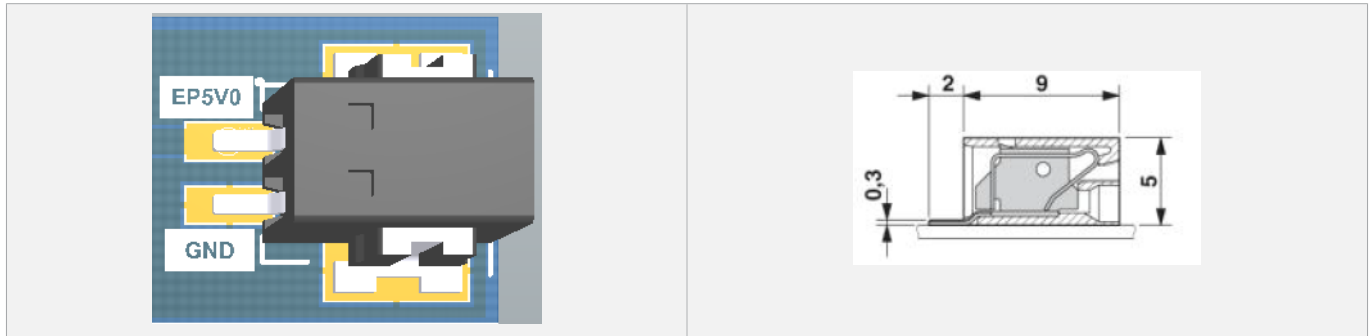

4.2 PROTO1 Xplained Pro ID System

The PROTO1 Xplained Pro board has the Xplained Pro hardware identification system implemented. When the board is connected via an Atmel Xplained Pro MCU board to Atmel Studio it will be identified and relevant information like the user guide will be shown. By default the ID device on the board is connected to the right angled extension header and the ID X pin of the vertical extension header on the right side of the board is unconnected. It is however possible to connect the ID X signal to the right angled extension header with the hardware changes described below. This makes it possible to use the PROTO1 Xplained Pro as an right angle extender for extension boards and Atmel Studio will recognize their ID. In order to do so, the PROTO1 Xplained Pro ID needs to be disconnected and the ID X signal needs to be connected. To disconnect the PROTO1 Xplained Pro ID just cut the cut-strap marked as ID PROTO1 (see [Figure 4-2, “ID PROTO1.” on page 9](#)) on the bottom side of the PCB.

Figure 4-2. ID PROTO1.

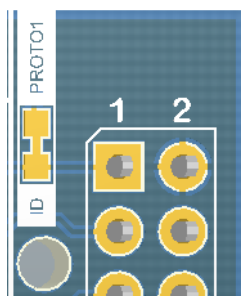

To connect the ID X signal, just solder a zero ohm resistor or a piece of wire to the open strap marked as ID X (see [Figure 4-3, “ID X.” on page 9](#)) on the bottom side of the PCB.

Figure 4-3. ID X.

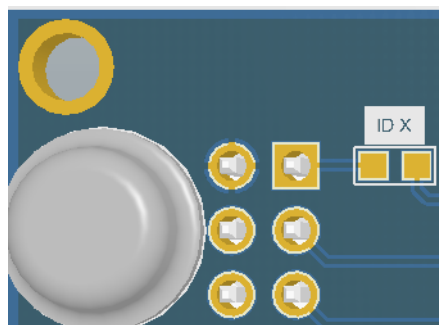

Now any connected Xplained Pro extension modules that are plugged into the vertical extension header on the right side of the board will be detected by Atmel Studio, the PROTO1 Xplained Pro extension board will not longer be detected.

4.3 Connecting the PROTO1 Xplained Pro

The lower part of the PROTO1 Xplained Pro board can be connected to all Xplained Pro MCU evaluation kits standard extension headers. If the upper break-off part, containing the additional power section, should be used, it is required to connect the board to the EXT1 header in order to connect to the Power header as well (see [Figure 4-4, “Example Connection.” on page 10](#)). To break off the upper section of the board break it along the V-CUT score line across the PCB.

Figure 4-4. Example Connection.

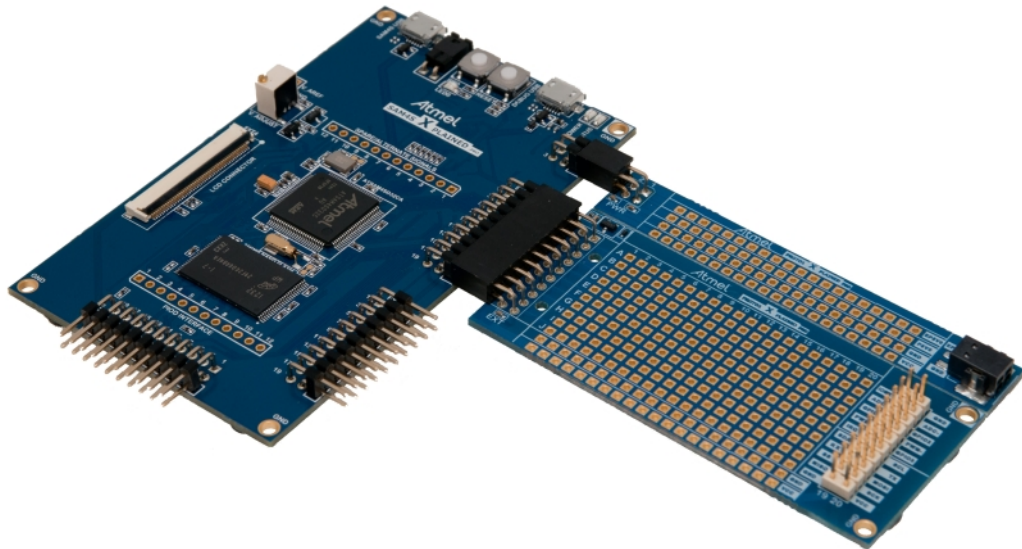

The connection indicated below (See [Figure 4-5, “Not Recommended PROTO1 Xplained Pro Connection.” on page 10](#)) may cause the power plug to short some of the EXT1 pins if it is connected externally. To avoid this, either move the PROTO1 Xplained Pro to another extension connector or break away the power section.

Figure 4-5. Not Recommended PROTO1 Xplained Pro Connection.

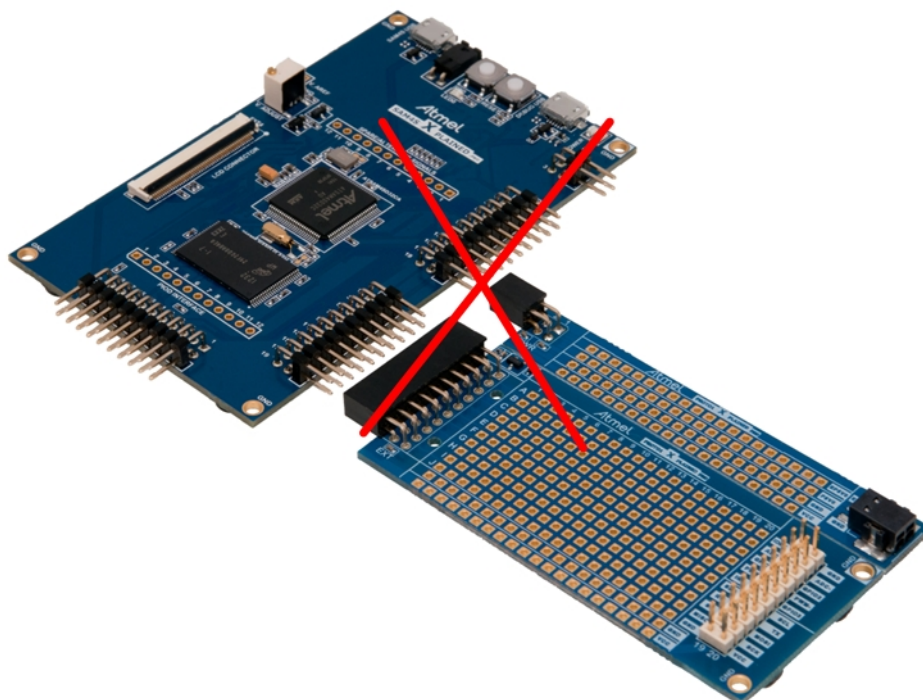

Note

Note that any remaining mousebite residues should be filed or cut away for optimum fit.

4.3.1 Connecting Xplained Extension Boards

It is also possible to interface Xplained top-modules via the PROTO1 Xplained Pro board. The signal layout on the extension connector below the white line, i.e. pins 11 - 20 is identical to the J1 connector (communication connector) on the Xplained series MCU boards (see [Figure 4-6, "External Connector." on page 11](#)).

Figure 4-6. External Connector.

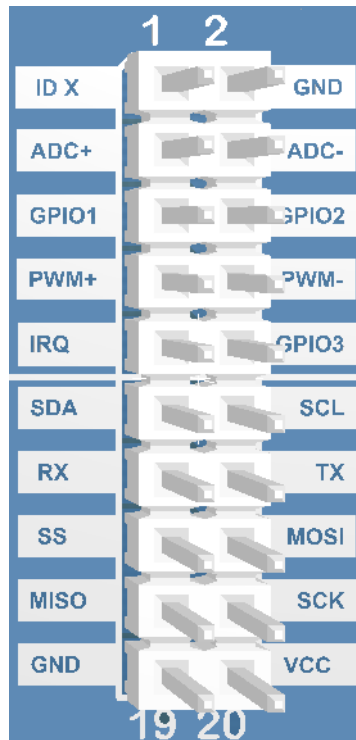

So for Xplained series top-modules that only uses this connector can be attached. Note that the extension connector on the Xplained Pro MCU board might not have all signals available due to lack of pin resources. This needs to be checked for each case. A mounting example is shown in the [Figure 4-7, "Xplained Series Sensor Board Mounted on PROTO1 Xplained Pro" on page 11](#) with a sensor board.

Figure 4-7. Xplained Series Sensor Board Mounted on PROTO1 Xplained Pro

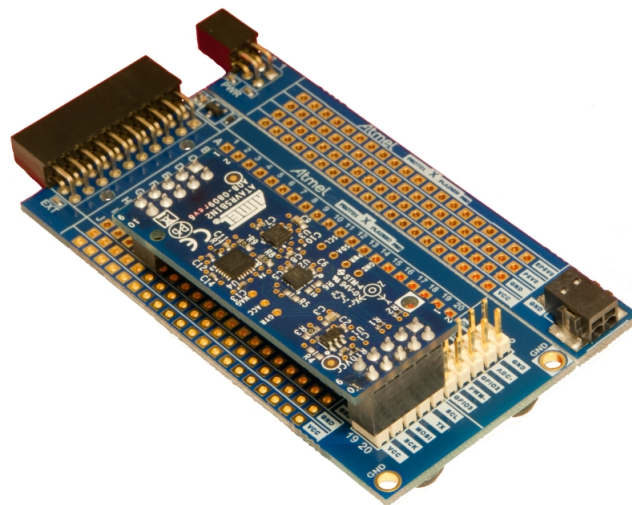

4.3.2 Using PROTO1 Xplained Pro With a Solderless Breadboard

It is possible to mount a 170 Tie-points solderless breadboard (size 47mm x 35mm) on to the prototype section on the PROTO1 Xplained Pro board to ease prototyping (see [Figure 4-8, "Solderless Breadboard Mounted on](#)

PROTO1 Xplained Pro.” on page 12). It lacks any GND/VCC rails so they need to be connected directly. These boards can be found at a low cost from lots of vendors on internet.

Figure 4-8. Solderless Breadboard Mounted on PROTO1 Xplained Pro.

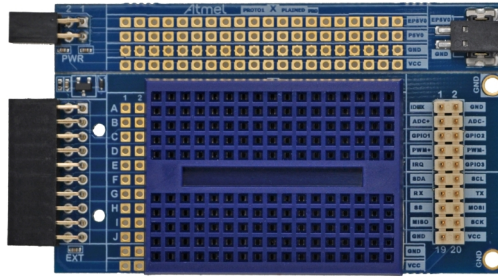

5. Hardware Revision History and Known Issues

5.1 Identifying Product ID and Revision

The revision and product identifier of Xplained Pro boards can be found in two ways, through Atmel Studio or by looking at the sticker on the bottom side of the PCB.

By connecting a Xplained Pro MCU board to a computer with Atmel Studio running, an information window will pop up. The first six digits of the serial number, which is listed under kit details, contain the product identifier and revision. Information about connected Xplained Pro extension boards will also appear in the Atmel Kits window.

The same information can be found on the sticker on the bottom side of the PCB. Most kits will print the identifier and revision in plain text as *A09-nnnn\rr* where *nnnn* is the identifier and *rr* is the revision. Boards with limited space have a sticker with only a QR-code which contains a serial number string.

The serial number string has the following format:

```
"nnnnrrssssssssss"  
n = product identifier  
r = revision  
s = serial number
```

The kit identifier for PROTO1 Xplained Pro is 1890.

5.2 Revision 2

Revision 2 of PROTO1 Xplained Pro is the initial released version.

PROTO1 Xplained Pro boards with a serial number that ends with a number lower than 19048 may have a wrong revision programmed into the Xplained Pro ID chip. This will only affect the information displayed by the Atmel Kits extension in Atmel Studio. It will not affect the operation of the board.

6. Document revision history

Document revision	Date	Comment
42080B	09/2013	Added errata about revision 2 of the board.
42080A	25/02/2013	First release

7. Evaluation board/kit important notice

This evaluation board/kit is intended for use for **FURTHER ENGINEERING, DEVELOPMENT, DEMONSTRATION, OR EVALUATION PURPOSES ONLY**. It is not a finished product and may not (yet) comply with some or any technical or legal requirements that are applicable to finished products, including, without limitation, directives regarding electromagnetic compatibility, recycling (WEEE), FCC, CE or UL (except as may be otherwise noted on the board/kit). Atmel supplied this board/kit "AS IS," without any warranties, with all faults, at the buyer's and further users' sole risk. The user assumes all responsibility and liability for proper and safe handling of the goods. Further, the user indemnifies Atmel from all claims arising from the handling or use of the goods. Due to the open construction of the product, it is the user's responsibility to take any and all appropriate precautions with regard to electrostatic discharge and any other technical or legal concerns.

EXCEPT TO THE EXTENT OF THE INDEMNITY SET FORTH ABOVE, NEITHER USER NOR ATMEL SHALL BE LIABLE TO EACH OTHER FOR ANY INDIRECT, SPECIAL, INCIDENTAL, OR CONSEQUENTIAL DAMAGES.

No license is granted under any patent right or other intellectual property right of Atmel covering or relating to any machine, process, or combination in which such Atmel products or services might be or are used.



Atmel Corporation 1600 Technology Drive, San Jose, CA 95110 USA **T:** (+1)(408) 441.0311 **F:** (+1)(408) 436.4200 | www.atmel.com

© 2013 Atmel Corporation. All rights reserved. / Rev.: 42080B-MCU-10/2013

Atmel®, Atmel logo and combinations thereof, Enabling Unlimited Possibilities®, and others are registered trademarks or trademarks of Atmel Corporation or its subsidiaries. Other terms and product names may be trademarks of others.

Disclaimer: The information in this document is provided in connection with Atmel products. No license, express or implied, by estoppel or otherwise, to any intellectual property right is granted by this document or in connection with the sale of Atmel products. EXCEPT AS SET FORTH IN THE ATMEL TERMS AND CONDITIONS OF SALES LOCATED ON THE ATMEL WEBSITE, ATMEL ASSUMES NO LIABILITY WHATSOEVER AND DISCLAIMS ANY EXPRESS, IMPLIED OR STATUTORY WARRANTY RELATING TO ITS PRODUCTS INCLUDING, BUT NOT LIMITED TO, THE IMPLIED WARRANTY OF MERCHANTABILITY, FITNESS FOR A PARTICULAR PURPOSE, OR NON-INFRINGEMENT. IN NO EVENT SHALL ATMEL BE LIABLE FOR ANY DIRECT, INDIRECT, CONSEQUENTIAL, PUNITIVE, SPECIAL OR INCIDENTAL DAMAGES (INCLUDING, WITHOUT LIMITATION, DAMAGES FOR LOSS AND PROFITS, BUSINESS INTERRUPTION, OR LOSS OF INFORMATION) ARISING OUT OF THE USE OR INABILITY TO USE THIS DOCUMENT, EVEN IF ATMEL HAS BEEN ADVISED OF THE POSSIBILITY OF SUCH DAMAGES. Atmel makes no representations or warranties with respect to the accuracy or completeness of the contents of this document and reserves the right to make changes to specifications and products descriptions at any time without notice. Atmel does not make any commitment to update the information contained herein. Unless specifically provided otherwise, Atmel products are not suitable for, and shall not be used in, automotive applications. Atmel products are not intended, authorized, or warranted for use as components in applications intended to support or sustain life.