



Features

- Small (10.4 x 6.0 x 2.2mm)
- Excellent bias repeatability over temperature
- Dual-axis MEMS accelerometer in a hermetically sealed ceramic LCC surface mount package for temperature and humidity resistance
- Five dynamic range options; $\pm 0.85g$, $\pm 2.5g$, $\pm 10g$, $\pm 30g$ $\pm 96g$
- Analogue and digital (SPI®) outputs for linear acceleration and temperature
- Wide bandwidth (typically 170Hz digital, 250Hz analogue)
- Temperature range -40 to +125°C
- Low power consumption (3mA Typ) from a 3.3V supply
- Integral temperature sensor
- RoHS compliant

Applications

- Aerospace and industrial
- Aircraft AHRS and controls
- Platform stabilisation
- Drilling guidance
- Surveying and mapping
- Land and marine navigation
- Transportation
- Inertial measurement units
- Levelling and tilt sensing

1 General Description

Gemini™ is a new family of integrated MEMS accelerometers from Silicon Sensing, providing high performance dual-axis linear acceleration measurement in a small surface mounted package. It comprises a dual-axis MEMS sensing device with a dedicated control ASIC in a single ceramic LCC package. Sensor data is output via analogue and digital (SPI®) interfaces.

The CAS200 series of parts provides two in-plane axes of linear acceleration sensing and is available in five different dynamic ranges:

- $\pm 0.85g$ - CAS211
- $\pm 2.5g$ - CAS212
- $\pm 10g$ - CAS213
- $\pm 30g$ - CAS214
- $\pm 96g$ - CAS215

CAS200 is supplied as a PCBA surface mountable standard LCC ceramic packaged device, which is hermetically sealed providing full environmental protection.

Precise linear acceleration sensing is achieved by a Silicon MEMS detector forming an orthogonal pair of sprung masses. Each mass provides the moving plate of a variable capacitance formed by an array of interlaced 'fingers'. This structure also provides critical damping to prevent resonant gain. Linear acceleration results in a change of capacitance which is measured by demodulation of the square wave excitation.

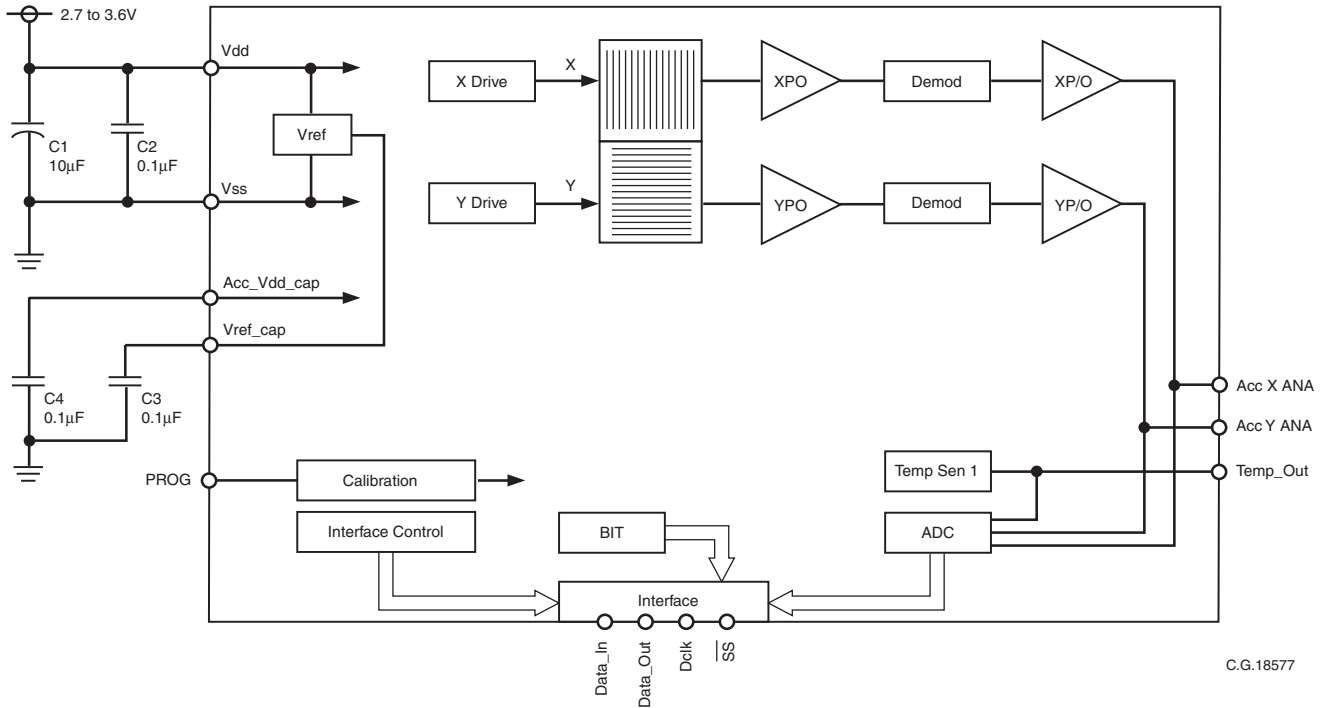

C.G.18577

Figure 1.1 CAS200 Functional Block Diagram

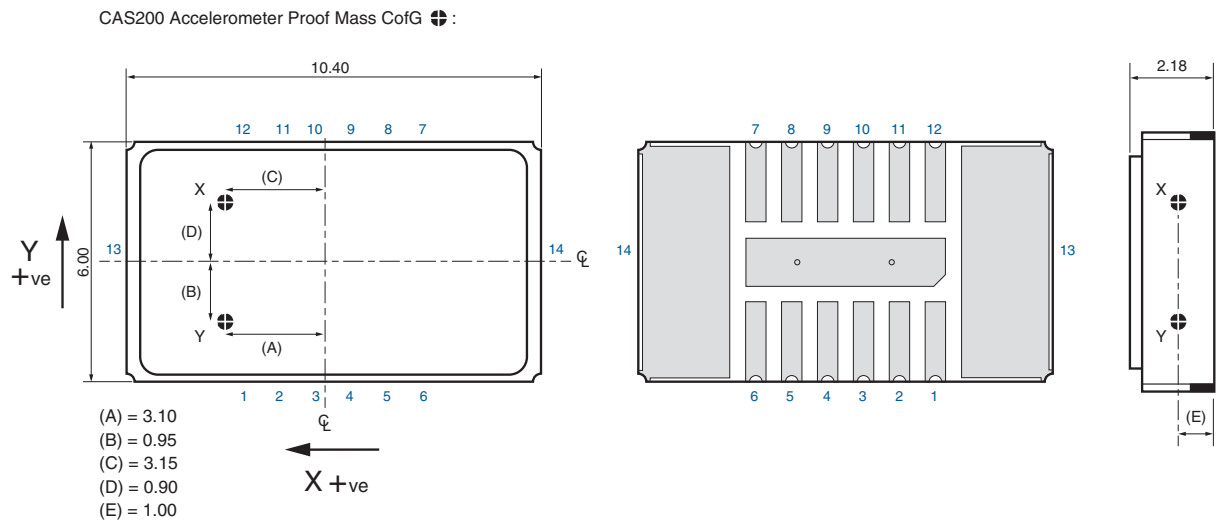

All dimensions in millimetres.

C.G.18580

Figure 1.2 CAS200 Overall Dimensions

2 Ordering Information

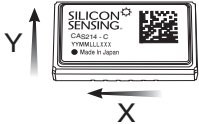
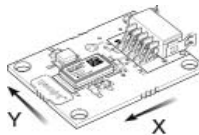
Part Number	Sense Axes	Description	Measurement Range	Mode	Overall Dimensions	Supply Voltage
					mm	V
CAS211		Dual-axis, (X,Y) linear accelerometer	±0.85g	Digital SPI® and Analogue	10.4x6.0x2.2H	2.7~3.6
CAS212			±2.5g			
CAS213			±10g			
CAS214			±30g			
CAS215			±96g			
CAS211-02-0302		Evaluation Boards for the CAS211, 212, 213, 214 or 215 parts (includes the sensor).	±0.85g			
CAS212-02-0302			±2.5g			
CAS213-02-0302			±10g			
CAS214-02-0302			±30g			
CAS215-02-0302			±96g			

3 Specification

Unless otherwise specified the following specification values assume Vdd = 3.15 to 3.45V over the temperature range -40 to +125°C.

3.1 Digital Output Specification

Parameter	CAS211	CAS212	CAS213	CAS214	CAS215	Notes
Dynamic range	±0.85g	±2.5g	±10g	±30g	±96g	–
Scale factor	33,500lsb/g	11,000lsb/g	2,800lsb/g	1,050lsb/g	300lsb/g	Nominal (non-ratiometric)
Scale factor error at +25°C	±1%	±1%	±1%	±1%	±1%	–
Scale factor variation over temperature	±1.2%	±1.2%	±1.2%	±1.2%	±1.2%	Uncompensated
Scale factor stability (1 year)	±1,000ppm	±1,000ppm	±1,000ppm	±1,000ppm	±1,000ppm	–
Scale factor non-linearity	0.5% FSR	0.5% FSR	2% FSR	2% FSR	2% FSR	Max error from best fit straight line over the full range
Bias setting error at +25°C	±335lsb	±110lsb	±28lsb	±31lsb	±30lsb	Uncompensated (see note 1)
Bias run to run variation at +25°C	±0.35mg	±0.75mg	±0.75mg	±3.0mg	±8.0mg	–
Bias stability (1 year)	±7.5mg	±7.5mg	±7.5mg	±25mg	±75mg	–
Bias variation over temperature	±50mg	±50mg	±50mg	±150mg	±500mg	Uncompensated
Resolution/threshold @1Hz	0.03mg	0.10mg	0.10mg	0.30mg	1.0mg	With over-sampling techniques
Noise spectral density	≤50µg/√Hz	≤150µg/√Hz	≤150µg/√Hz	≤350µg/√Hz	≤1,200µg/√Hz	Typical
Bandwidth	>170Hz	>170Hz	>170Hz	>170Hz	>170Hz	–
Vibration rectification	0.15mg/g ² @ 0.5g _{rms}	0.15mg/g ² @ 2.0g _{rms}	0.15mg/g ² @ 8.0g _{rms}	0.1mg/g ² @ 12g _{rms}	0.1mg/g ² @ 12g _{rms}	Bias change under applied random vibration 20Hz to 2kHz

Note 1:

The bias setting error is a fixed offset, set with 3.3V applied to the device. This bias may change for other applied voltages and can be removed by external compensation.

3.2 Analogue Output Specification

Parameter	CAS211	CAS212	CAS213	CAS214	CAS215	Notes
Dynamic range	±0.85g	±2.5g	±10g	±30g	±96g	–
Scale factor	1,150mV/g	375mV/g	96mV/g	36mV/g	10mV/g	Nominal (ratiometric)
Scale factor error at +25°C	±1.5%	±1.5%	±1.5%	±1.5%	±1.5%	–
Scale factor variation over temperature	±1.2%	±1.2%	±1.2%	±1.2%	±1.2%	Uncompensated
Scale factor stability (1 year)	±1,000ppm	±1,000ppm	±1,000ppm	±1,000ppm	±1,000ppm	–
Scale factor asymmetry	±750ppm	±750ppm	±1,500ppm	±2,000ppm	±2,000ppm	Difference between best fit straight line slope in positive and negative ranges
Scale factor non-linearity	0.5% FSR	0.5% FSR	2% FSR	2% FSR	2% FSR	Max error from best fit straight line over the full range
Bias run to run variation at +25°C	±0.35mg	±0.75mg	±0.75mg	±3.0mg	±8.0mg	–
Bias stability (1 year)	±7.5mg	±7.5mg	±7.5mg	±25mg	±75mg	–
Bias variation over temperature	±50mg	±50mg	±50mg	±150mg	±500mg	Uncompensated (see note 2)
Resolution/threshold @1Hz	0.03mg	0.10mg	0.10mg	0.30mg	1.00mg	–
Noise spectral density	≤50µg/√Hz	≤150µg/√Hz	≤150µg/√Hz	≤350µg/√Hz	≤1,200µg/√Hz	Typical
Bandwidth	>250Hz	>250Hz	>250Hz	>250Hz	>250Hz	–
Vibration rectification	0.15mg/g ² @ 0.5g _{rms}	0.15mg/g ² @ 2.0g _{rms}	0.15mg/g ² @ 8.0g _{rms}	0.1mg/g ² @ 12g _{rms}	0.1mg/g ² @ 12g _{rms}	Bias change under applied random vibration 20Hz to 2kHz

Note 2:

The acceleration outputs are at a nominal Vdd/2 voltage. Typical variation from device to device is ±10.0mV, and may change with variation in power supply voltage. The fixed offset can be removed by external compensation.

Specification Continued

CAS211, CAS212, CAS213, CAS214 & CAS215				
Parameter	Minimum	Typical	Maximum	Notes
Temperature Sensor (Digital Output):				
Scale factor	-	11lsb/°C	-	At +25°C
Offset	-	2336lsb	-	At +25°C
Temperature Sensor (Analogue Output):				
Scale factor	-	5mV/°C	-	-
Offset	-	1.49V	-	At +25°C
Repeatability	-5°C	-	+5°C	-
Start Up:				
Start up time	-	-	20ms	-
Recovery time	-	-	10ms	From over range/shock
Physical:				
Mass	-	0.4grams	-	-
Misalignment	-20mrad	-	20mrad	-
Orthogonality	-	1.7mrad	-	Internal relative to the other sensor

4 Absolute Minimum/Maximum Ratings

	Minimum	Maximum
Electrical:		
Vdd	-0.3V	+4.0V
ESD protection	-	2kV HBM
Environmental:		
Temperature (operating)	-40°C	+125°C
Temperature (storage)	-55°C	+150°C
Humidity	-	90% RH non-condensing
Shock (operating)	-	1,000g 1ms 1/2 sine
Shock (non-operational)	-	10,000g 0.5ms 1/2 sine (CAS214, CAS215) 6,500g 0.5ms 1/2 sine (CAS211, CAS212, CSA213)
Life:		
Unpowered	15 years	-
Powered	12,000 hours	-

Notes:

Exposure to the Absolute Maximum Ratings for extended periods may affect performance and reliability.

5 Typical Performance Characteristics

Graphs showing typical performance characteristics for Gemini™ are shown below:

Note: Typical data is with the device powered from a 3.3V supply.

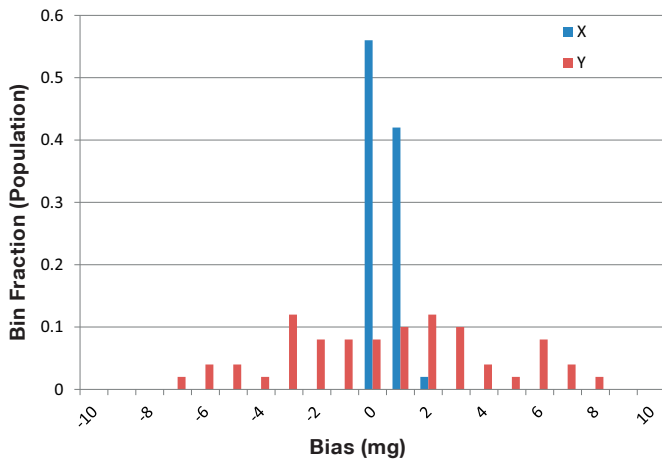

Figure 5.1 CAS211 (0.85g) Bias Distribution at 20°C

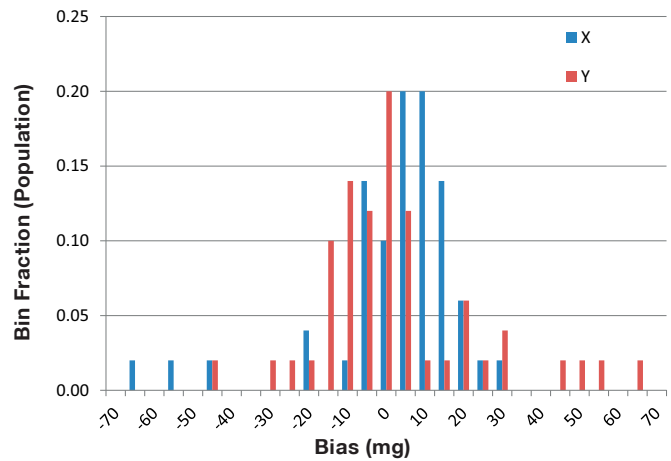

Figure 5.2 CAS212 (2.5g) Bias Distribution at 20°C

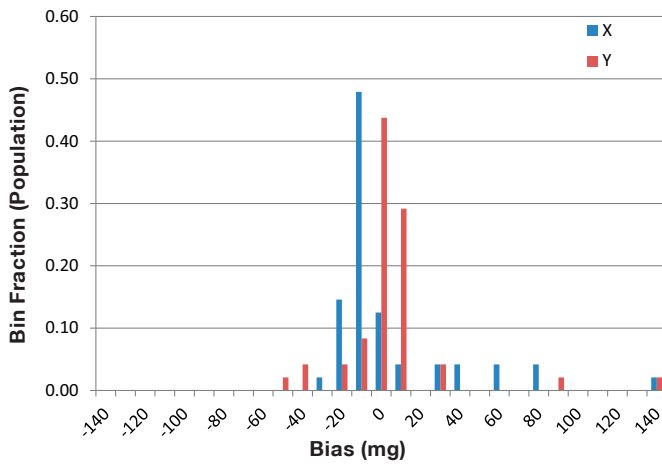

Figure 5.3 CAS213 (10g) Bias Distribution at 20°C

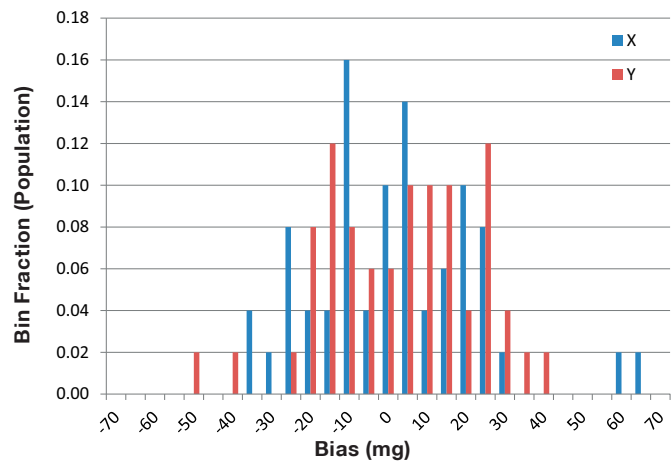

Figure 5.4 CAS214 (30g) Bias Distribution at 20°C

Typical Performance Characteristics Continued

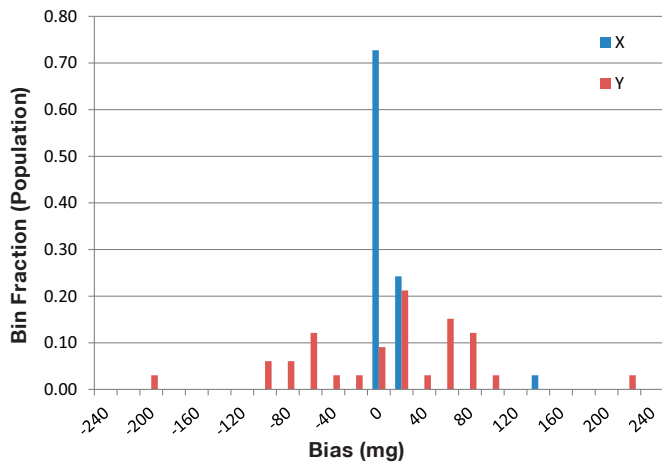

Figure 5.5 CAS215 (96g) Bias Distribution at 20°C

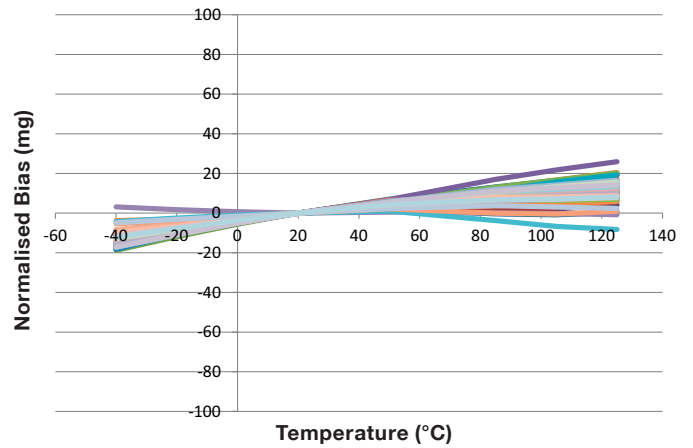

Figure 5.6 CAS211 (0.85g) Accelerometer Y Bias variation with Temperature

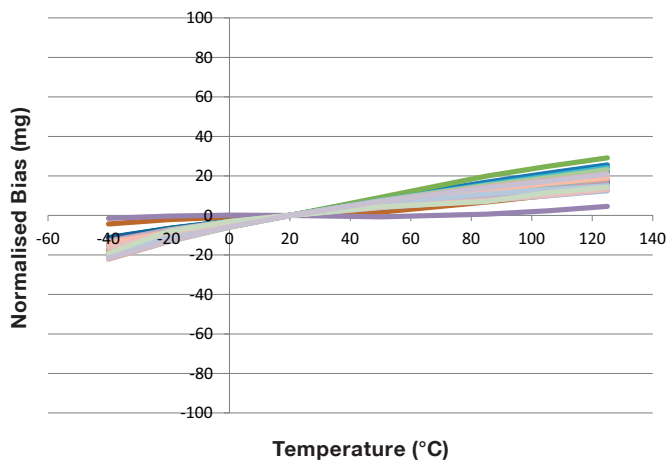

Figure 5.7 CAS212 (2.5g) Accelerometer Y Bias variation with Temperature

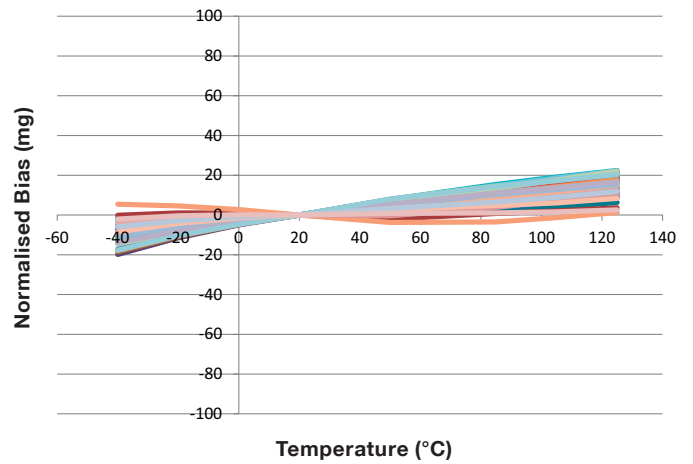

Figure 5.8 CAS213 (10g) Accelerometer Y Bias variation with Temperature

Typical Performance Characteristics Continued

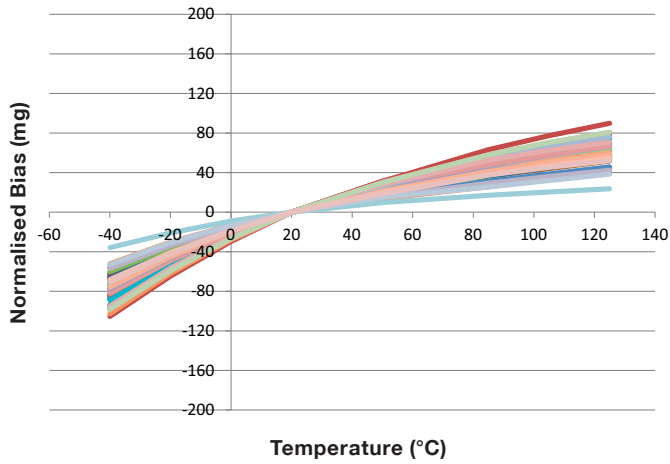

Figure 5.9 CAS214 (30g) Accelerometer Y Bias variation with Temperature

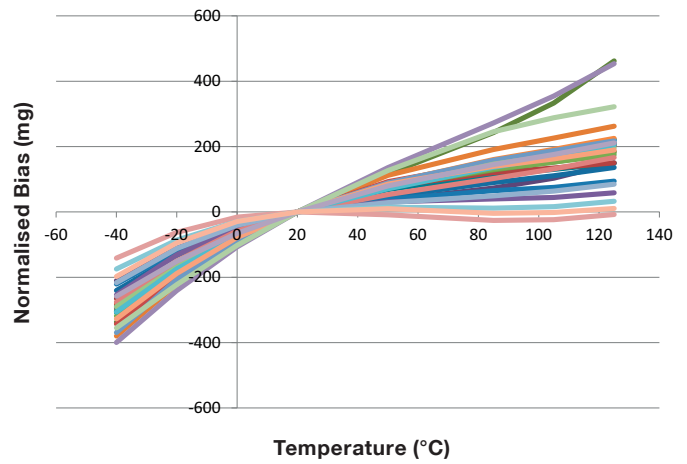

Figure 5.10 CAS215 (96g) Accelerometer Y Bias variation with Temperature

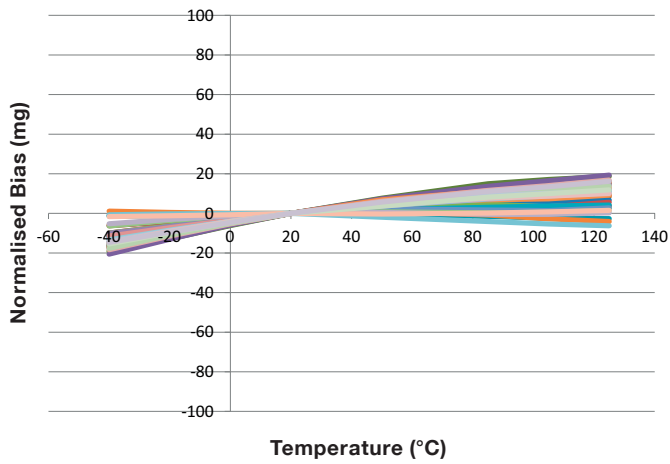

Figure 5.11 CAS211 (0.85g) Accelerometer X Bias variation with Temperature

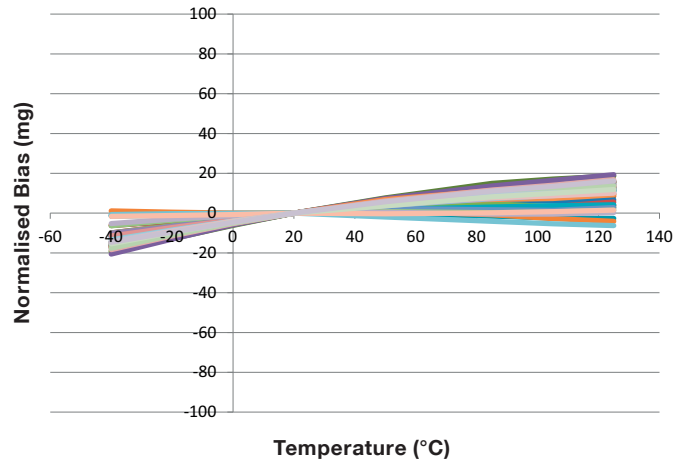

Figure 5.12 CAS212 (2.5g) Accelerometer X Bias variation with Temperature

Typical Performance Characteristics Continued

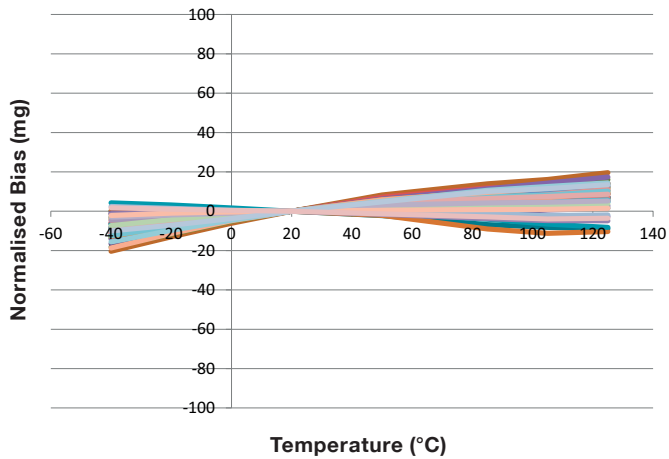

Figure 5.13 CAS213 (10g) Accelerometer X Bias variation with Temperature

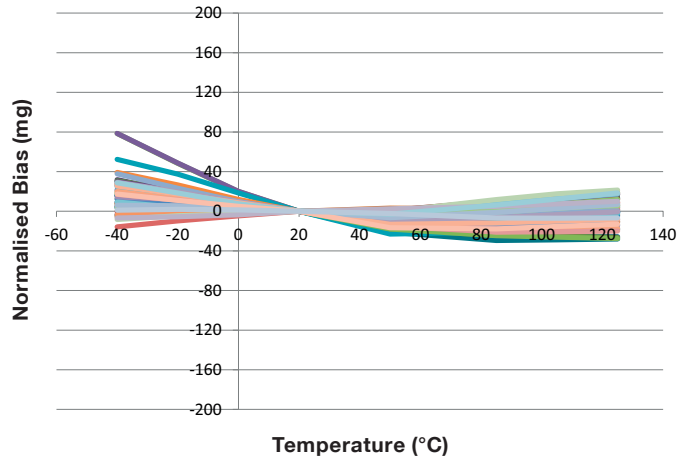

Figure 5.14: CAS214 (30g) Accelerometer X Bias variation with Temperature

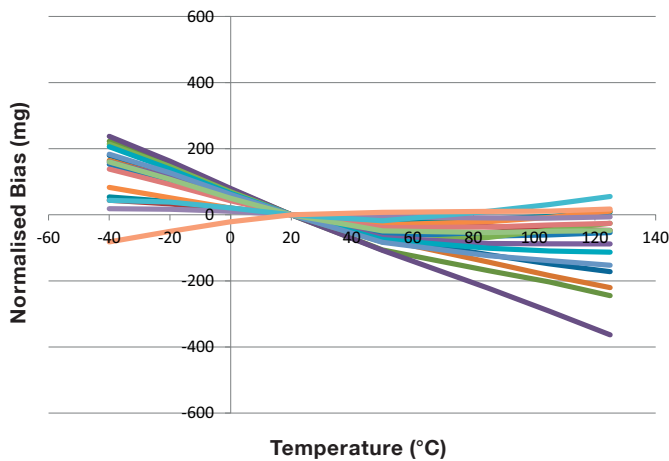

Figure 5.15: CAS215 (96g) Accelerometer X Bias variation with Temperature

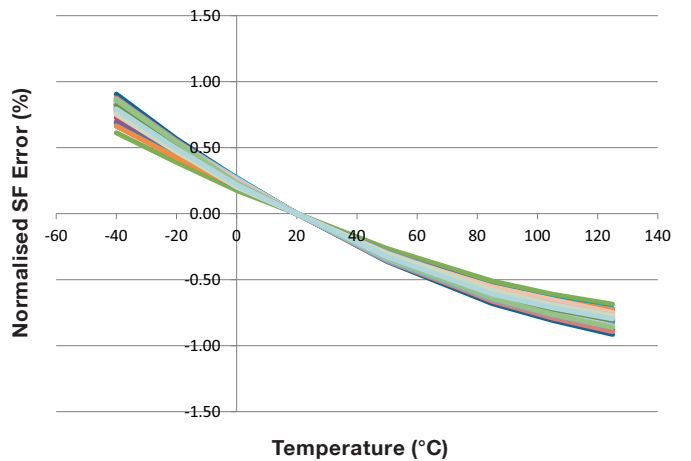

Figure 5.16 CAS211 (0.85g) Accelerometer Y SF Error with Temperature

Typical Performance Characteristics Continued

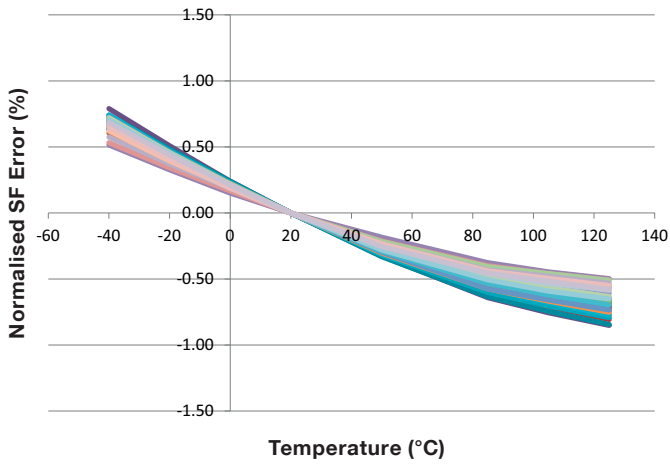

Figure 5.17 CAS212 (2.5g) Accelerometer Y SF Error with Temperature

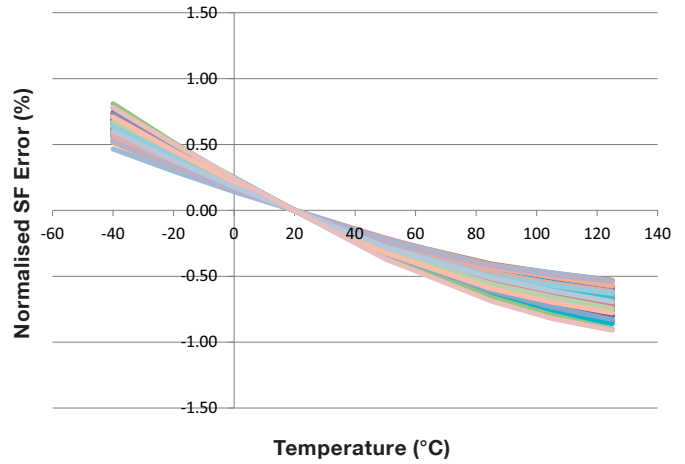

Figure 5.18 CAS213 (10g) Accelerometer Y SF Error with Temperature

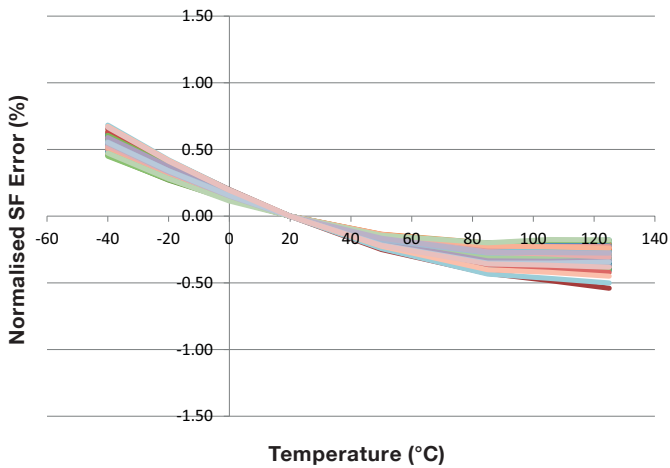

Figure 5.19 CAS214 (30g) Accelerometer Y SF Error with Temperature

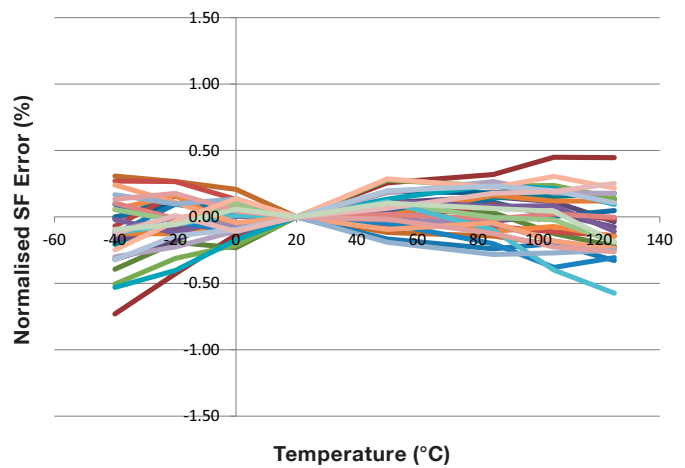

Figure 5.20 CAS215 (96g) Accelerometer Y SF Error with Temperature

Typical Performance Characteristics Continued

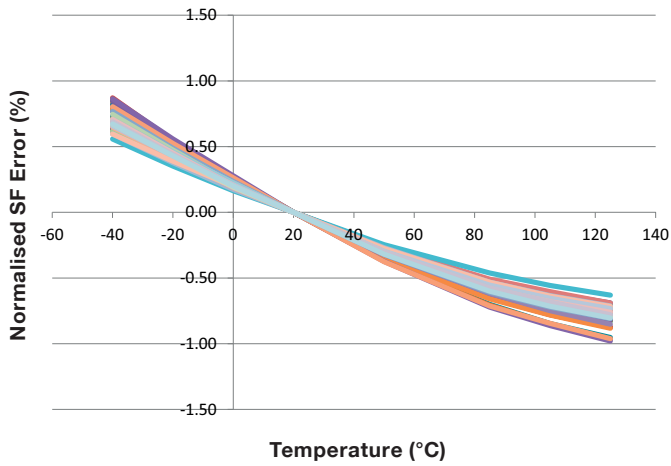

Figure 5.21 CAS211 (0.85g) Accelerometer X SF Error with Temperature

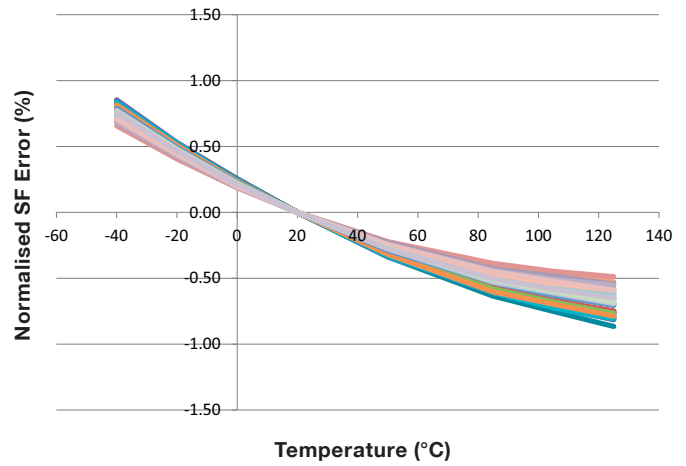

Figure 5.22 CAS212 (2.5g) Accelerometer X SF Error with Temperature

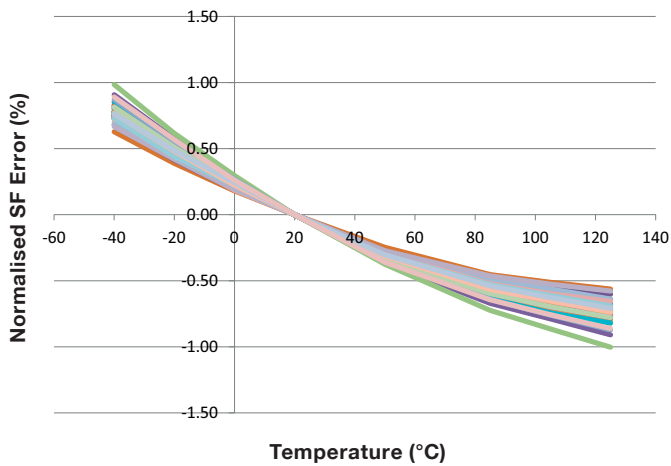

Figure 5.23 CAS213 (10g) Accelerometer X SF Error with Temperature

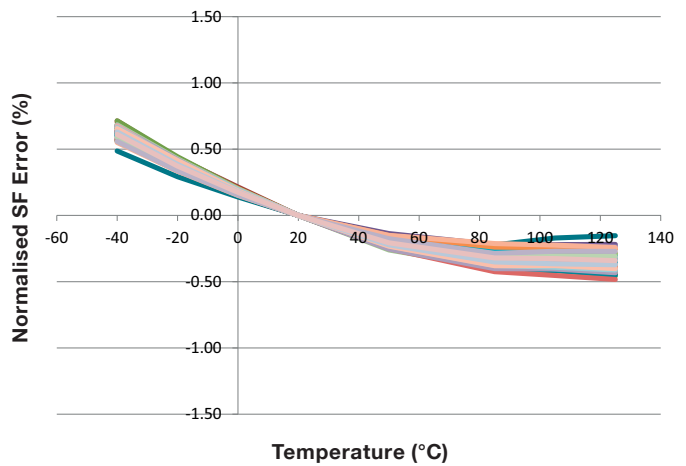

Figure 5.24 CAS214 (30g) Accelerometer X SF Error with Temperature

Typical Performance Characteristics Continued

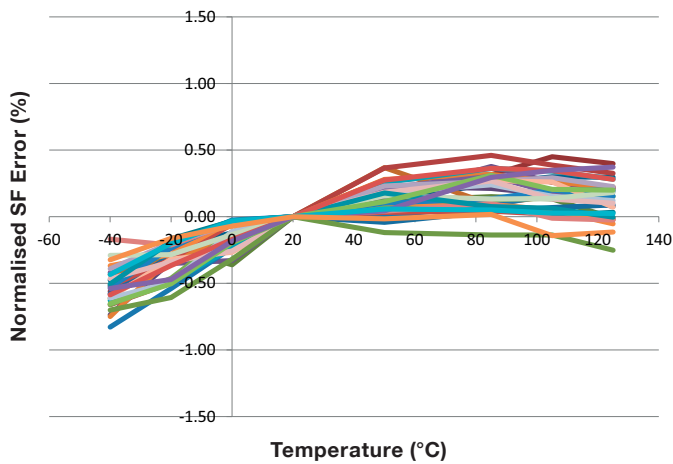

Figure 5.25 CAS215 (96g) Accelerometer X SF Error with Temperature

6 Glossary of Terms

ASIC	Application Specific Integrated Circuit	POR	Power On Reset
BIT	Built-In Test	PPO	Primary Pick-Off
BW	Bandwidth	SF	Scale Factor
CBIT	Commanded Built-In Test	SMT	Surface Mount Technology
CofG	Centre of Gravity	SOG	Silicon On Glass
DAC	Digital to Analogue Converter	T.B.A.	To Be Advised
DRIE	Deep Reactive Ion Etch	T.B.C.	To Be Confirmed
DSBSC	Double Side-Band Suppressed Carrier Signal		
ESD	Electro-Static Damage		
HBM	Human Body Model		
IPC	Institute of Printed Circuits		
LCC	Leadless Chip Carrier		
MEMS	Micro-Electro Mechanical Systems		
NEC	Not Electrically Connected (Do Not Connect)		
PCBA	Printed Circuit Board Assembly		

Pin Number	Pin Name	Signal Direction	Pin Function
1	Vdd_Cap	–	Used to smooth supply to CAS200. A 100nF X7R dielectric ceramic capacitor is recommended.
2	PROG	Input	For factory use, must be connected to Vdd in operation
3	Temp_Out	Output	Analogue temperature output. Scaling 5mV/°C at 3.3V supply - Ambient temperature reading of 1.474V
4	Acc X ANA	Output	X Accelerometer analogue output
5	Vss	–	Return connection for applied power (0V)
6	Vref_Cap	–	Used to decouple the internal voltage reference via an external capacitor. A 100nF X7R dielectric ceramic capacitor is recommended.
7	Data_Out	Output	Digital mode: SPI_MISO. Only enabled when SPI_Select is low. Tri-stated when SPI_SELECT is high.
8	Dclk	Input	Digital mode: SPI_CLK Internal Pull-up
9	Data_In	Input	Digital mode: SPI_MOSI Internal Pull-up
10	\overline{SS}	Input	Digital mode: SPI_SELECT Internal Pull-up
11	Acc Y ANA	Input	Y Accelerometer analogue output
12	Vdd	–	Positive power supply to the sensor. Range from 2.7 to 3.6V. Should be decoupled with a 100nF X7R dielectric ceramic capacitor, a bulk storage capacitor of 10µF should be nearby.
Centre and Side Pads (13,14 & 15)	NEC	–	Not Electrically Connected. These pins provide additional mechanical fixing to the Host System and should be soldered to an unconnected pad.

Table 7.1 Input/Output Pin Definitions

Parameter	Minimum	Maximum	Units
Supply			
Supply voltage (functional)	2.7	3.6	V
Supply voltage (full specification)	3.15	3.45	V
Supply voltage limits	-0.3	4.0	V
Supply current	–	5	mA
Discrettes			
Input voltage low	-0.5	0.3xVdd	V
Input voltage high	0.7xVdd	Vdd+0.5	V
Output voltage low	–	0.4	V
Output voltage high	0.8xVdd	–	V
Analogue			
Output impedance	–	<1k	Ω
Output load capacitance	–	300	pF
Input impedance	50k	–	Ω
Output source/sink current	–	1	mA

Table 7.2 Electrical Characteristics

7.2 Digital Interface

This section defines the SPI® interface timing and the message types and formats to and from the Gemini™ CAS200 sensor.

The SPI® interface, when selected, will be a 4-wire interface with the following signals:

Dclk	SPI® clock
Data_In	Message data input to sensor
Data_Out	Message data output by sensor
SS	Select sensor

Signal electrical characteristics are defined in Table 7.3.

Parameter	Minimum	Maximum	Units
Input voltage low	-0.5	0.3xVdd	V
Input voltage high	0.7xVdd	Vdd+0.5	V
Output voltage low	-	0.4	V
Output voltage high	0.8xVdd	-	V
Leakage current	-2	2	µA
Pull-up current	10	50	µA

Table 7.3 SPI® Electrical Characteristics

SPI_SELECT, SPI_CLK and SPI_MOSI all have internal pull-up resistors in the sensor ASIC.

SPI_MISO is held in tri_state if SPI_SELECT is High and is driven if SPI_SELECT is Low.

7.3 Signal Timing

The interface will transfer 6 bytes (48 bits) in each message. The message rate will be 1kHz (recommended), (1Hz-min, 10kHz-max) with a SPI® clock frequency of 1MHz (nom), (100kHz-min 8MHz-max). A sampling rate greater than 500Hz is recommended to reduce the effects of aliasing.

The sensor will be a slave on the interface. All accesses shall use SPI® Mode 0.

Figure 7.5 specifies the interface timing for correct operation.

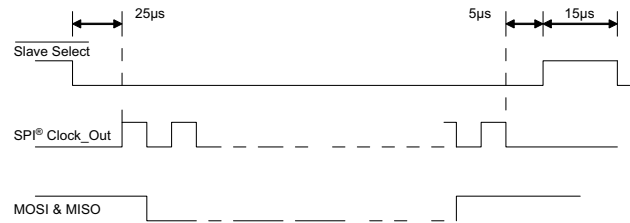

Figure 7.5 SPI® Timing Diagram

7.4 SPI® Message Format

This section defines the types and formats of the messages to the Gemini™ sensor.

7.4.1 Messages to ASIC (MOSI)

The messages to the sensor shall be sent in the following order:

- Byte 1 Command Byte (transmitted first, MSB first)
- Byte 2 Data 1
- Byte 3 Data 2
- Byte 4 Data 3
- Byte 5 Data 4
- Byte 6 Checksum (see note 3)

Data Format:

Command Byte	Bit 7	Set to 0	
	Bit 6	'0' = CBIT disabled '1' = CBIT enabled	
	Bit 5	Set to 0	
	Bit 4	Set to 0	
	Bits 3:0	Message Type	
	'0001'	Acceleration Y and X Request	
	'0010'	Status and Temperature Request	
	'0000'	SSSL Use Only	} Do not use
	'0011'	SSSL Use Only	
	'0100'	SSSL Use Only	
	'0101'	SSSL Use Only	
	'0110'	SSSL Use Only	
	'0111'	SSSL Use Only	
	'1000'	SSSL Use Only	
	'1001'	SSSL Use Only	
	'1010'	SSSL Use Only	
	'1011'	SSSL Use Only	
	'1100'	SSSL Use Only	
	'1101'	SSSL Use Only	
	'1110'	SSSL Use Only	
	'1111'	SSSL Use Only	

Message Data:

The following table defines the content of each byte of the input message.

Message Type	Data Byte	Byte Content
Acc Y/Acc X or Status/Temp	1	Bits (7.0) set to 0x00
	2	Bits (7.0) set to 0x00
	3	Bits (7.0) set to 0x00
	4	Bits (7.0) set to 0x00

Table 7.4 Message Content to Gemini™

Example message data:

- To request Acc Y and Acc X data only.

Command Byte = 0x01
 Data 1 Byte = 0x00
 Data 2 Byte = 0x00
 Data 3 Byte = 0x00
 Data 4 Byte = 0x00
 Checksum = 0xFE

- To request Status and Temperature.

Command Byte = 0x02
 Data 1 Byte = 0x00
 Data 2 Byte = 0x00
 Data 3 Byte = 0x00
 Data 4 Byte = 0x00
 Checksum = 0xFD

- To request CBIT and Acc Y and Acc X data.

Command Byte = 0x41
 Data 1 Byte = 0x00
 Data 2 Byte = 0x00
 Data 3 Byte = 0x00
 Data 4 Byte = 0x00
 Checksum = 0xBE

- To request CBIT and Status and Temperature.

Command Byte = 0x42
 Data 1 Byte = 0x00
 Data 2 Byte = 0x00
 Data 3 Byte = 0x00
 Data 4 Byte = 0x00
 Checksum = 0xBD

7.4.2 Message from Gemini™ (MISO)

The messages from the sensor shall be sent in the following order.

- Byte 1: Status Byte (MSB transmitted first)
- Byte 2: Data 1
- Byte 3: Data 2
- Byte 4: Data 3
- Byte 5: Data 4
- Byte 6: Checksum (see notes 3 and 4)

The data is output in 2's complement format, most significant byte first.

Data Format:

The Status Byte content depends on the message requested.

Status Byte	Bit 7	Sensor BIT Status '1' = BIT Failed '0' = Sensor OK
	Bit 6	ACC 1 BIT Status '1' = Acc Y Failed '0' = Acc Y OK
	Bit 5	ACC 2 BIT Status '1' = Acc X Failed '0' = Acc X OK
	Bit 4	'1' = Previous Input Checksum BIT Failed '0' = Previous Input Checksum BIT OK
	Bit 3	'0' = CBIT disabled '1' = CBIT enabled
	Bit 2:0	Output Message Type '001' = Acc Y/ Acc X '010' = Status Message/ Temperature Message '000' } '011' } Not used '100' } '101' } '110' } '111' }

Message Data Content:

The output message data content will depend on the command byte from the previous input message. The content is indicated by bits (2:0) of the Status byte.

Message Type	Data Byte	Byte Content
Acc Y/Acc X	1	Bits (7:0) - Acc Y MS bits (15:8)
	2	Bits (7:0) - Acc Y LS bits (7:0)
	3	Bits (7:0) - Acc X MS bits (15:8)
	4	Bits (7:0) - Acc X LS bits (7:0)
Status/Temp	1	Status Byte 1 (see note 5) Bit (7:6) - acc_bit_status Bit 5 - vref_cap_bit Bit 4 - acc_cap_bit Bit 3 - cbit_en Bit 2 '0' = OTP Parity OK '1' = OTP Parity Fail Bit 1 '0' = Previous input checksum Message Checksum OK '1' = Previous input checksum Message Checksum Fail Bit 0 '1'
	2	Bits (7:0) - (set to '0x00')
	3	Bits (7:0) - Temperature MS bits (15:8)
	4	Bits (7:0) - Temperature LS bits (7:0)

Table 7.5 Message Content from ASIC

Notes:

3. The checksum is the LS byte of the 1's complement of the first 5 bytes of message. If the checksum is incorrect the input message will be ignored and the checksum error flagged in the status byte of the next SPI® message. The content of the message following a bad checksum message shall be the message type selected in the last 'good' message. The message type shall default on power-up to Acc Y/Acc X message.

4. The checksum for the output message is calculated before the message is loaded into the SPI® registers. When the checksum is about to be calculated, the Data Bytes are stored and updates to them are inhibited. The Checksum is then calculated on the Status Byte and these 4 Data Bytes. The Status Byte can continue to be updated for a short time after the Checksum has been calculated. Therefore when the Status Byte, 4 Data Bytes and the Checksum are loaded into the SPI® register there is a small chance that the Checksum will be incorrect. It is therefore advised that if a Checksum Error is detected that the Status Byte should still be interrogated for the Status, such as BIT Fault.

5. For the status byte the following conditions apply.

Acc_bit_Status (0) = Acc Y '0' = Pass, '1' = Fail
Acc_bit_Status (1) = Acc X '0' = Pass, '1' = Fail
Vref_cap_bit '0' = Pass, '1' = Fail
Acc_cap_bit '0' = Pass, '1' = Fail
CBit_en '0' = CBIT OFF, '1' = CBIT ON

7.5 CBIT

The Gemini™ sensor has a Commanded Built in Test (CBIT) function which stimulates the output to give a synthetic acceleration output. This allows the acceleration channel to be functionally tested, identifying potential failure.

CBIT can be requested using the Command Byte as detailed in Section 7.4.1. The sensor will respond by applying a fixed offset to both acceleration outputs. The offset applied depends on the CAS variant being used, see Table 7.6 for details. The offset added will have a ±20% tolerance due to MEMS tolerance effects. The time taken to apply these offsets will be less than 35ms.

The intrusive nature of CBIT is such that whilst the sensor may continue to be used to indicate acceleration, the performance is not guaranteed while CBIT is asserted.







For full performance acceleration measurement, it is recommended that 35ms is allowed to elapse following the de-assertion of CBIT to allow the sensor to settle again.

Parameter	CAS200 Variant	Offset Added
Acceleration (both axes)	CAS215 (96g)	32.2g
	CAS214 (30.0g)	10g
	CAS213 (10.0g)	3.85g
	CAS212 (2.50g)	0.96g
	CAS211 (0.85g)	0.24g

Table 7.6 CBIT Offset for CAS200 Sensor

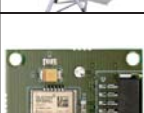
8 Design Tools and Resources Available

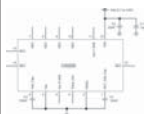
The following is planned to be available from the website in the near future.

Item	Description of Resource	Part Number	Order/Download
	Gemini™ Brochure: A one page sales brochure describing the key features of the Gemini™ Accelerometers.	CAS200-00-0100-131	Download (www.siliconsensing.com)
	Gemini™ CAS200 Datasheet: Full technical information on all part number options. Specification and other essential information for assembling and interfacing to Gemini™ Accelerometers, and getting the most out of them.	CAS200-00-0100-132	Download (www.siliconsensing.com)
	Gemini™ Presentation: A useful presentation describing the features, construction, principles of operation and applications for the Gemini™ Accelerometers.	—	Download (www.siliconsensing.com)
	Gemini™ evaluation board: Single Gemini™ fitted to a small PCBA for easy customer evaluation and test purposes. Refer to page 3 for ordering information.	CAS211-02-0302 CAS212-02-0302 CAS213-02-0302 CAS214-02-0302 CAS215-02-0302	Order
	Solid Model CAD files for Gemini™ Accelerometers: Available in .STP and .IGS file format	CAS200-00-0100-408	Download (www.siliconsensing.com)
	Library Parts: Useful library component files of Gemini™ Accelerometers: DxDesigner Schematic Symbols. PADS Decal (Footprint) PADS Part Type File.	—	Download (www.siliconsensing.com)
	Reference Circuit: A useful reference circuit design gerber files for the Gemini™ Accelerometer for use in host systems.	—	Download (www.siliconsensing.com)
	Questions and Answers: Some useful questions asked by customers and how we've answered them. This is an informal (uncontrolled) document intended purely as additional information.	—	Download (www.siliconsensing.com)
	RoHS compliance statement for Gemini™: Gemini™ is fully compliant with RoHS.	—	Download (www.siliconsensing.com)

9 Cleaning

Due to the natural resonant frequency and amplification factor ('Q') of the sensor, ultrasonic cleaning should NOT be used to clean the Gemini™ Accelerometer.

10 Soldering Information

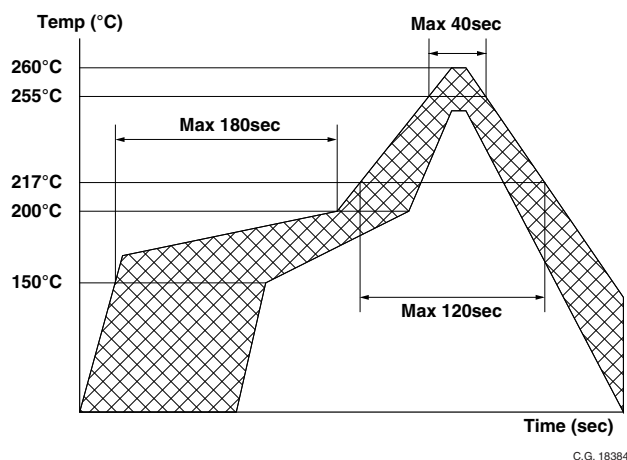

Figure 10.1 Recommended Reflow Solder Profile

11 Part Markings

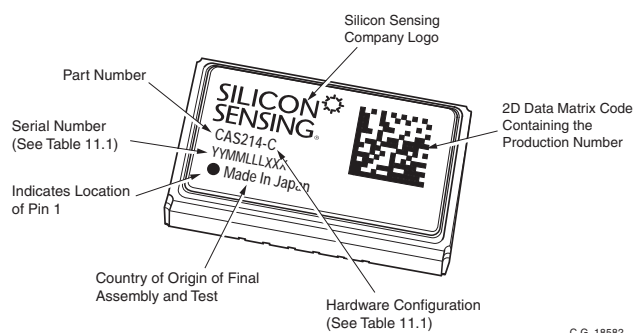

Figure 11.1 Part Marking

Item	Code	Range
Configuration	C	1 - Z
Year number	YY	00 - 99
Month number	MM	01 - 12
Lot number	LLL	000 - 999
Serial number	XXX	001 - 999

Table 11.1 Part Marking (Serial Number)

12 Packaging Information

Gemini™ sensors are supplied in tape format as either straight strips, or on either full-size or mini-reels, depending on the quantity being shipped. Table 12.1 defines the packaging method:

Shipping Quantity	Gemini™
Qty < 100	Strip of tape
100 ≥ Qty ≤ 1,000	Tape and mini-reel (approx. Ø175mm)
Qty > 100	Tape and full-size reel (approx. Ø330mm)

Table 12.1 Packaging Tape and Reel Format According to Shipping Quantity

The following information in this section defines the packaging for shipments using full-size reels.

Layer	Type	Quantity
CAS200	Tape and Reel	Max. 1500 pcs/ 1 Reel
Inner Bag	Aluminium Damp-proof Bag	1 Reel/Bag
Inner Box	Cardboard Box	Inner Bag x 1/Inner Box
Outer Box	Cardboard Box	Inner Box/Outer Box

Table 12.2 Packaging Information (Full-Size Reel)

Item	Dimension	Quantity	Material
Reel	DR2 23316C	1 Reel	PS
Emboss Tape	TE1612-091009-2	1 Roll	PS
Cover Tape	ALS-ATA 13.5mm x 480m	1 Roll	PET, PE, PS
Label for Reel	40mm x 80mm	1 label/Reel	Paper
Desiccant	FA 10g	1 Inner Bag	-
Inner Bag	0.101mm x 450mm x 530mm	1 Reel/Inner Bag	MB4800
Tray	451mm x 429mm x 55mm	2 Tray/Outer Box	-
Pad	451mm x 429mm x 20mm	3 Pad/Outer Box	-
Inner Box	413mm x 391mm x 52mm	2 Inner Box/Outer Box	Cardboard
Outer Box	462mm x 440mm x 208mm	1 Box	Cardboard
Label for Outer Box	102mm x 127mm	1 label/Outer Box	Paper

Table 12.3 Packaging Specification (Full-Size Reel)

Reel Information

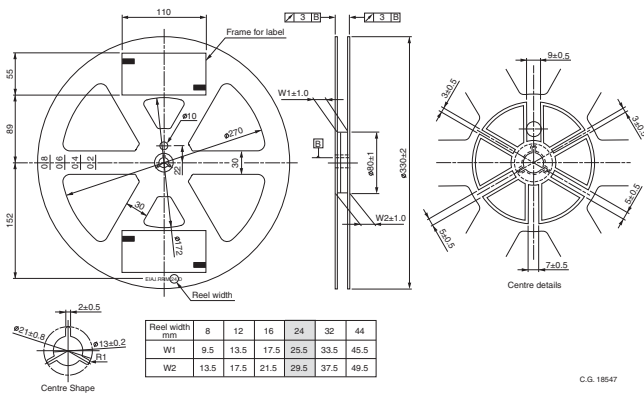

Emboss Tape Carrier Information

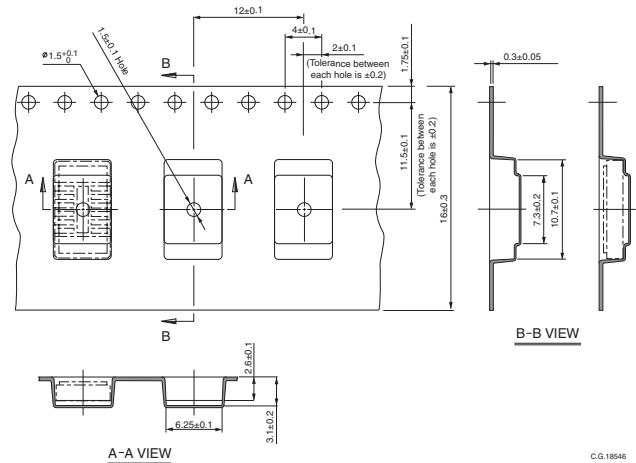

Tape Information

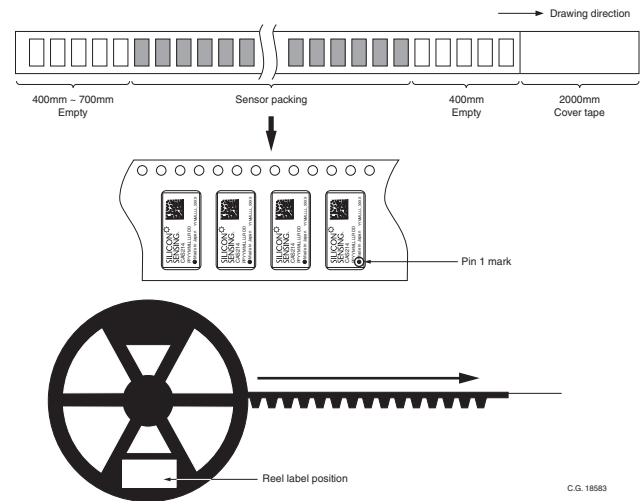

Label for Reel Information

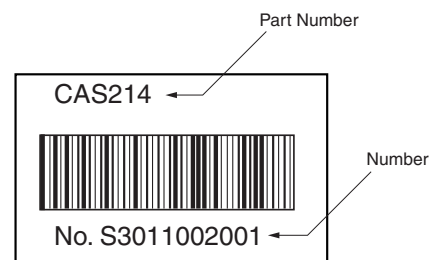

Inner Bag Packing Information

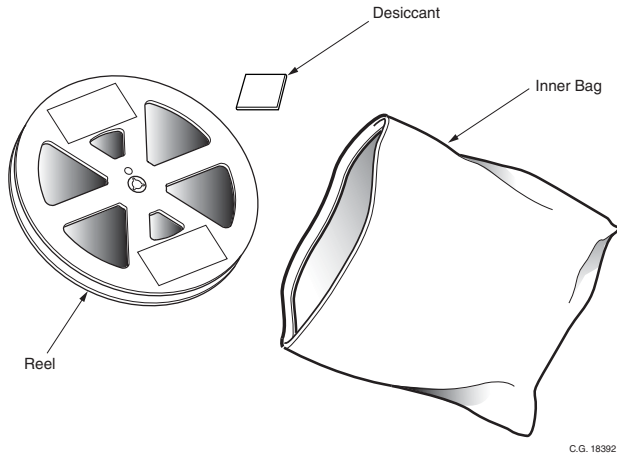

Inner Box Packing Information

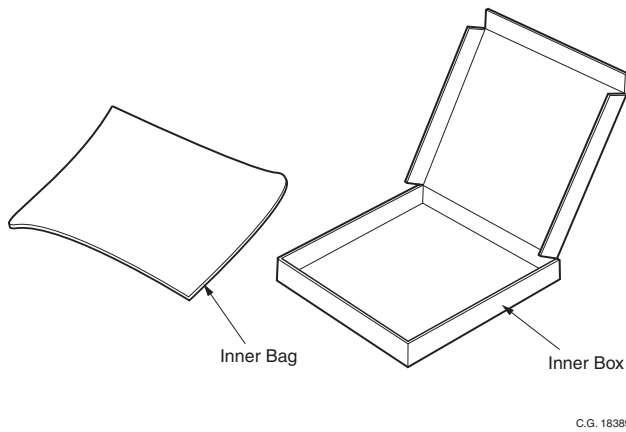

Outer Box Packing Information

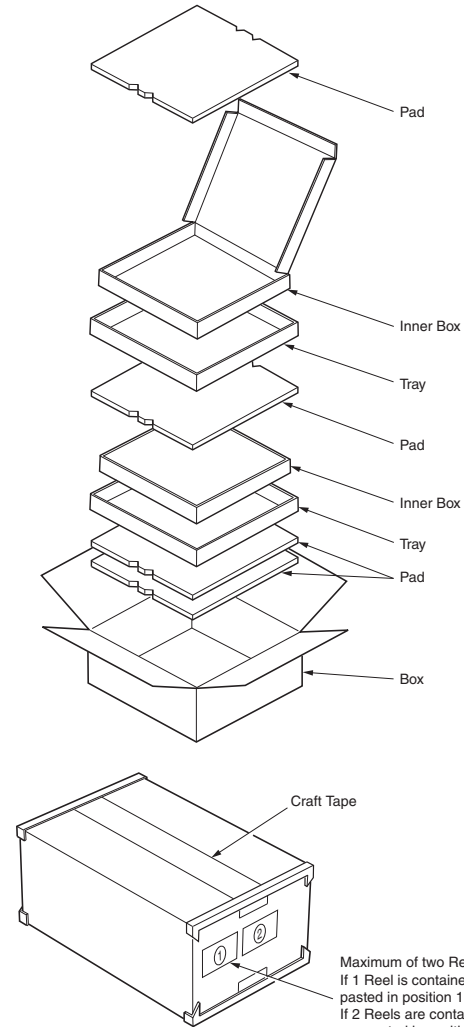

13 Internal Construction and Theory of Operation

Construction

Gemini™ is supplied as a PCBA surface mountable LCC ceramic packaged device. It comprises four main components; Silicon On Glass (SOG) Dual-Axis MEMS Accelerometer, ASIC and, the Package Base and Lid. The MEMS Sensors and ASIC are housed in a hermetically sealed package cavity with a nitrogen back-filled partial vacuum, this has particular advantages over sensors supplied in plastic packages which have Moisture Sensitivity Level limitations.

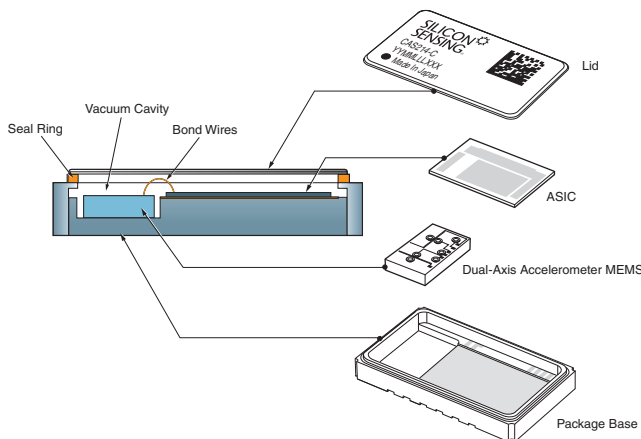

Figure 13.1 CAS200 Main Components

Silicon MEMS Dual-Axis Accelerometer

The Gemini™ dual-axis open loop accelerometer is a one-piece resonating silicon MEMS structure anodically bonded to top and bottom glass substrates to form a hermetically sealed Silicon on Glass (SOG) wafer sub-assembly. A DRIE bulk silicon process is used to create two orthogonal finger-like spring/seismic proof mass structures, each measuring 1.8mm square, and with a resonant frequency of 1.8kHz to 5.2kHz. Figure 13.2 shows a schematic cross section through the SOG wafer.

Capacitive drive and pick-off signals are transmitted by wire bond interconnections, in through-glass vias, between the metallised transducer plates on the MEMS proof mass and the Gemini™ ASIC.

Multiple inter-digitated fingers create increased capacitance thus enabling a high signal-to-noise ratio. The fingers are tapered to increase the resonant frequency and also have a high aspect ratio to provide highly stable performance. The differential gaps between the static electrode fingers and those of the proof mass provide an air squeeze film with near-critical damping.

Control of the accelerometer is handled by the Gemini™ ASIC.

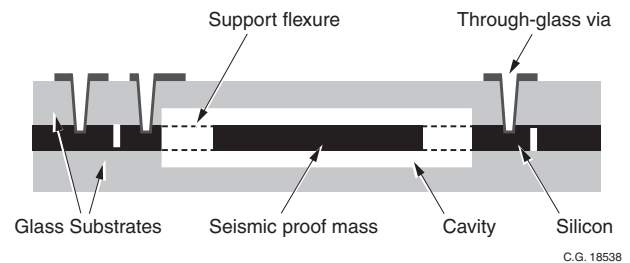

Figure 13.2 Schematic Section of the Silicon On Glass Accelerometer MEMS Wafer Sub-Assembly

ASIC

The ASIC is a 3.93mm x 3.2mm device fabricated using 0.35µm CMOS process. ASIC and MEMS are physically separate and are connected electrically by using gold bond wires and thus the ASIC has no MEMS-to-ASIC internal tracking, meaning there is reduced noise pick-up. Gold bond wires also connect the ASIC to the internal bond pads on the Package Base.

Package Base and Lid

The LCC ceramic Package Base is a multi-layer aluminium oxide construction with internal bond wire pads connected through the Package Base via integral multi-level tungsten interconnects to a series of external solder pads. Similar integral interconnects in the ceramic layers connect the Lid to Vss, thus the sensitive elements are inside a Faraday shield. Internal and external pads are electroplated gold on electroplated nickel.

The Package Base incorporates a seal ring on the upper layer onto which a Kovar® metal Lid is seam welded using a rolling resistance electrode, thus creating a totally hermetic seal. Unlike other MEMS

packages available on the market, Gemini™ has a specially developed seam weld process which eliminates the potential for internal weld spatter. Inferior designs can cause dislodged weld spatter which affects reliability due to interference with the moving MEMS element.

Theory of Operation (Accelerometer)

The accelerometer contains a seismic ‘proof mass’ with multiple fingers suspended via a ‘spring’, all of which is formed in the silicon MEMS structure. The proof mass is anodically bonded to the top and bottom glass substrates and thereby fixed to the Gemini™ Package Base.

When the Gemini™ sensor is subjected to a linear acceleration along its sensitive axis the proof mass tends to resist motion due to its own inertia, therefore the mass and it’s fingers becomes displaced with respect to the interdigitated fixed electrode fingers. Gas between the fingers provides a damping effect. This displacement induces a differential capacitance between the moving and fixed silicon fingers which is proportional to the applied acceleration.

Capacitor plate groups are electrically connected in pairs at the top and bottom of the proof mass. In-phase and anti-phase waveforms are applied by the Gemini™ ASIC separately to the ‘left’ and ‘right’ finger groups. The demodulated waveforms provide a signal output proportional to linear acceleration.

Figures 13.3(a) and 13.4(b) provide schematics of the accelerometer structure and control loop respectively.

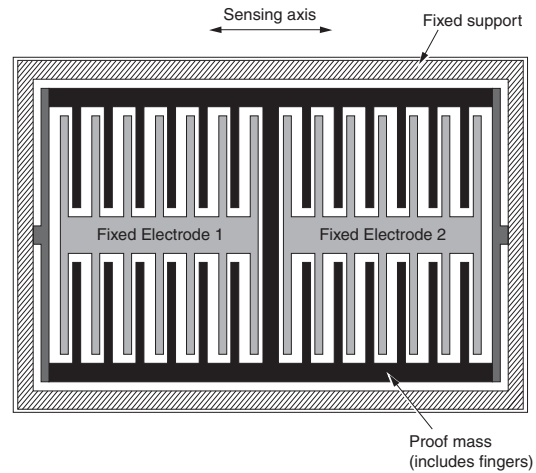

Figure 13.3(a) Schematic of Accelerometer Structure

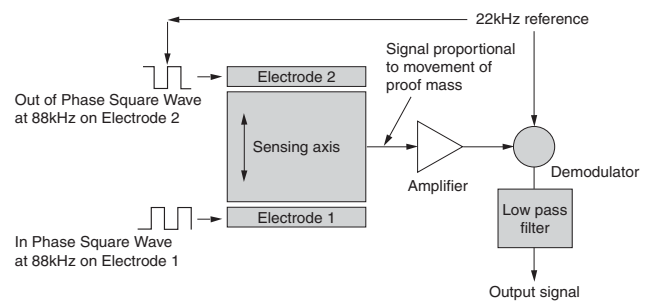

Figure 13.4(b) Schematic of Accelerometer Control Loop

14 Patent Applications

The following patent applications have been filed for the Gemini™ Accelerometers:

Patent Application	Status
US7047808	Granted
US7267006	Granted
EP1718980	Granted



Dual-Axis Accelerometer

CAS200 Technical Datasheet



www.siliconsensing.com

Notes

Silicon Sensing Systems Limited
Cliffa Road Southway
Plymouth Devon
PL6 6DE United Kingdom
T: +44 (0)1752 723330
F: +44 (0)1752 723331
W: siliconsensing.com

Silicon Sensing Systems Japan Limited
1-10 Fuso-Cho
Amagasaki
Hyogo 6600891 Japan
T: +81 (0)6 6489 5868
F: +81 (0)6 6489 5919
W: siliconsensing.com

Specification subject to change without notice.

© Copyright 2013
Silicon Sensing Systems Limited
All rights reserved.
Printed in England 09/2013
Date 23/09/2013

CAS200-00-0100-132 Rev 5
DCR No. 710005472