

PROGRAMMABLE | MULTI-RANGE ON DELAY, INTERVAL ON, FLASHER & TRUE OFF DELAY

TR-6 SERIES TIME RANGER™



- ◆ Each unit has 16 timing ranges built-in (8 on True Off Delay)
- ◆ Selecting a range is easy using a rotary switch (no math is required or DIP switches to set)
- ◆ Timing ranges up to 2 hours (30 minutes on True Off Delay)
- ◆ Uses industry-standard 8 pin octal sockets
- ◆ 10A DPDT output contacts



FUNCTION ■	INPUT VOLTAGE 50/60Hz.	PRODUCT NUMBER	WIRING/ SOCKETS
ON DELAY A	120V AC/DC 12V AC/DC 24V AC/DC 240V AC	TR-60222 TR-60226 TR-60228 TR-60221	8 PIN OCTAL 70169-D DIAGRAM 1
INTERVAL ON B	120V AC/DC 12V AC/DC 24V AC/DC 240V AC	TR-60522 TR-60526 TR-60528 TR-60521	
FLASHER (OFF 1st) E	120V AC/DC 12V AC/DC 24V AC/DC 240V AC	TR-60822 TR-60826 TR-60828 TR-60821	
FLASHER (ON 1st) F	120V AC/DC 12V AC/DC 24V AC/DC 240V AC	TR-60922 TR-60926 TR-60928 TR-60921	
TRUE OFF DELAY R	120V AC/DC 12V AC/DC 24V AC/DC 240V AC	TR-60622 TR-60626 TR-60628 TR-60621	

■ See "Definitions of Timing Functions".

TIMING RANGES

Select one of the 8 or 16 built-in time ranges by setting the rotary switch per a chart on the unit and adjust within that range using the knob on top:

TR-602, 605, 608 & 609 SERIES

Dial Setting	Timing Range
A	0.1 - 0.25 Sec.
B	0.2 - 0.5 Sec.
C	0.3 - 1 Sec.
D	0.5 - 2 Sec.
E	1 - 4 Sec.
F	2 - 8 Sec.
G	4 - 15 Sec.
H	8 - 30 Sec.
I	15 - 60 Sec.
J	30 - 120 Sec.
K	1 - 4 Min.
L	2 - 8 Min.
M	4 - 15 Min.
N	8 - 30 Min.
O	15 - 60 Min.
P	30 - 120 Min.

TR-606 SERIES

Dial Setting	Timing Range
A	0.05 - 5 Sec.
B	0.1 - 10 Sec.
C	0.3 - 30 Sec.
D	0.6 - 60 Sec.
E	1.8 - 180 Sec.
F	3 - 300 Sec.
G	0.1 - 10 Min.
H	0.3 - 30 Min.



Better. By Design.

800.238.7474

WWW.MACROMATIC.COM

SALES@MACROMATIC.COM

Sockets & Accessories available

Build your Time Delay Relays with the [Online Product Builder](#)

PROGRAMMABLE | MULTI-RANGE OFF DELAY, SINGLE SHOT & WATCHDOG

TR-6 SERIES TIME RANGER™

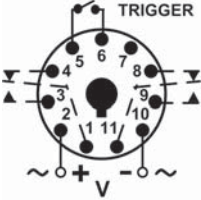
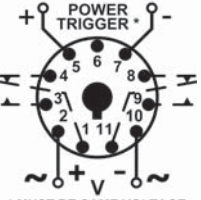
FUNCTION ■	INPUT VOLTAGE 50/60Hz.	PRODUCT NUMBER	WIRING/ SOCKETS
OFF DELAY Control Switch Trigger C	120V AC/DC 12V AC/DC 24V AC/DC 240V AC	TR-61622 TR-61626 TR-61628 TR-61621	11 PIN OCTAL 70170-D 
SINGLE SHOT Control Switch Trigger D	120V AC/DC 12V AC/DC 24V AC/DC 240V AC	TR-61522 TR-61526 TR-61528 TR-61521	DIAGRAM 2
WATCHDOG Control Switch Trigger (Retriggerable Single Shot) J	120V AC/DC 12V AC/DC 24V AC/DC 240V AC	TR-61322 TR-61326 TR-61328 TR-61321	DIAGRAM 2
OFF DELAY Power Trigger C	120V AC/DC 12V AC/DC 24V AC/DC 240V AC	TR-61922 TR-61926 TR-61928 TR-61921	11 PIN OCTAL 70170-D 
SINGLE SHOT Power Trigger D	120V AC/DC 12V AC/DC 24V AC/DC 240V AC	TR-61722 TR-61726 TR-61728 TR-61721	DIAGRAM 4
WATCHDOG Power Trigger (Retriggerable Single Shot) J	120V AC/DC 12V AC/DC 24V AC/DC 240V AC	TR-61822 TR-61826 TR-61828 TR-61821	DIAGRAM 4

■ See "Definitions of Timing Functions".

TIMING RANGES

Select one of the 16 built-in time ranges by setting the rotary switch per a chart on the unit and adjust within that range using the knob on top:

TR-613, 615, 616, 617,
618 & 619 SERIES

Dial Setting	Timing Range
A	0.1 - 0.25 Sec.
B	0.2 - 0.5 Sec.
C	0.3 - 1 Sec.
D	0.5 - 2 Sec.
E	1 - 4 Sec.
F	2 - 8 Sec.
G	4 - 15 Sec.
H	8 - 30 Sec.
I	15 - 60 Sec.
J	30 - 120 Sec.
K	1 - 4 Min.
L	2 - 8 Min.
M	4 - 15 Min.
N	8 - 30 Min.
O	15 - 60 Min.
P	30 - 120 Min.

Sockets & Accessories available



- ◆ Each unit has 16 timing ranges built-in
- ◆ Selecting a range is easy using a rotary switch (no math is required or DIP switches to set)
- ◆ Timing ranges up to 2 hours
- ◆ Uses industry-standard 11 pin octal sockets
- ◆ 10A DPDT output contacts



Better. By Design.

800.238.7474

WWW.MACROMATIC.COM

SALES@MACROMATIC.COM

Build your Time Delay Relays with the [Online Product Builder](#)

PROGRAMMABLE | MULTI-RANGE REPEAT CYCLE & DELAYED INTERVAL

TR-6 SERIES TIME RANGER™



- ◆ Each unit has 16 timing ranges built-in
- ◆ Selecting a range is easy using a rotary switch (no math is required or DIP switches to set)
- ◆ Timing ranges up to 24 hours
- ◆ Independently selectable & adjustable ON & OFF times
- ◆ Uses industry-standard 8 or 11 pin octal sockets
- ◆ 10A DPDT output contacts

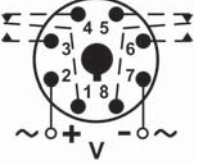
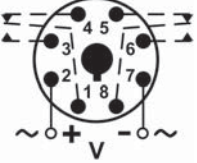
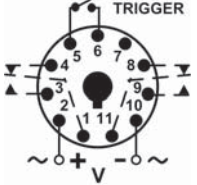

FUNCTION ■	INPUT VOLTAGE 50/60Hz.	PRODUCT NUMBER	WIRING/SOCKET
REPEAT CYCLE* (OFF Time First Followed By ON Time and Repeating) L	120V AC/DC 12V AC/DC 24V AC/DC 240V AC	TR-63122 TR-63126 TR-63128 TR-63121	8 PIN OCTAL 70169-D 
REPEAT CYCLE* (ON Time First Followed By OFF Time and Repeating) M	120V AC/DC 12V AC/DC 24V AC/DC 240V AC	TR-65122 TR-65126 TR-65128 TR-65121	
DELAYED INTERVAL* (OFF Time Followed by ON Time Followed by OFF State Until Reset) N	120V AC/DC 12V AC/DC 24V AC/DC 240V AC	TR-66122 TR-66126 TR-66128 TR-66121	DIAGRAM 1
DELAYED INTERVAL* Control Switch Trigger (OFF Time Followed by ON Time Followed by OFF State Until Reset) P	120V AC/DC 12V AC/DC 24V AC/DC 240V AC	TR-66522 TR-66526 TR-66528 TR-66521	11 PIN OCTAL 70170-D 

* These units have independently selectable & adjustable ON & OFF times. See www.macromatic.com/onoff for more information.

■ See "Definitions of Timing Functions".

TIMING RANGES

Select one of the 16 built-in time ranges by setting the rotary switch per a chart on the unit and adjust within that range using the knob on top:

TR-631, 651, 661 & 665 SERIES

Dial Setting	Timing Range
A	0.6 - 2.5 Sec.
B	1.5 - 5 Sec.
C	2.5 - 10.5 Sec.
D	5 - 21 Sec.
E	10 - 42 Sec.
F	0.4 - 1.4 Min.
G	0.7 - 2.8 Min.
H	1.5 - 5.5 Min.
I	3 - 11 Min.
J	5.5 - 22.5 Min.
K	11 - 45 Min.
L	0.4 - 1.5 Hr.
M	0.8 - 3 Hr.
N	1.5 - 6 Hr.
O	3 - 12 Hr.
P	6 - 24 Hr.

Sockets & Accessories available



Better. By Design.

800.238.7474

WWW.MACROMATIC.COM

SALES@MACROMATIC.COM

Build your Time Delay Relays with the [Online Product Builder](#)

TR-6 SERIES TIME RANGER™

APPLICATION DATA

Voltage Tolerance:

AC Operation: +10/-15% of nominal at 50/60 Hz.
DC Operation: +10/-15% of nominal.

Load (Burden):

2 VA

Setting Accuracy:

Maximum Setting (Adjustable): +5%, -0%
Minimum Setting (Adjustable): +0%, -50%

Repeat Accuracy (constant voltage and temperature):

> 2 Seconds Delay ±0.1%
0.1 - 2 Seconds Delay ±2%

Reset Time:

On Delay/Interval/Repeat Cycle/Delayed Interval: 0.1 Seconds
Off Delay/Single Shot/Watchdog/
Triggered Delayed Interval: 0.04 Seconds

Start-up Time:

(Time from when power is applied until unit is timing)
120 & 240V units 0.05 Seconds
12, 24 & 48V units 0.08 Seconds

Maintain Function Time:

(Time unit continues to operate after power is removed)
0.01 Seconds for all units

Temperature:

12-120V Input Voltage: -28° to 65°C (-18° to 150°F)
240V Input Voltage: -28° to 50°C (-18° to 122°F)

Triggering Off Delay, Single Shot or Watchdog Units:

Timing sequence must be initiated only after input voltage is applied to unit. Minimum required trigger switch closure time is 0.1 seconds.

Compatibility:

Using a solid state switch to initiate the time sequence is acceptable. See www.macromatic.com/leakage or contact Macromatic for information regarding leakage current limits and other solid state design considerations.

Output Contacts:

(All TR-6 Series Products except TR-606 True Off Delay)
DPDT 10A @ 240V AC/30V DC,
1/2HP @ 120/240V AC (N.O.), 1/3HP @ 120/240V AC (N.C.)
B300 & R300; AC15 & DC13

(TR-606 True Off Delay)

DPDT 10A @ 240V AC; 8A @ 28V DC,
1/2 HP @ 240V AC, 1/4HP @ 120V AC
B300 & R300

Life:

Mechanical: 10,000,000 operations (2,000,000 operations on TR-606 Series only)
Full Load: 100,000 operations

IMPORTANT FOR TR-606 SERIES ONLY: These relays are shipped from the factory in the OFF state. A shock to the relay during shipping or installation may cause it to change to the ON state. It is recommended that input voltage be applied to the product for at least 0.1 second and removed to cycle the unit to the OFF state prior to use in the application. Please note that it will take as long as the OFF Delay setting to reset the unit once input voltage has been removed.

Approvals:

(All TR-6 Series Products except TR-606 True Off Delay)



(TR-606 True Off Delay only)



(All TR-6 Series Products)



DIMENSIONS

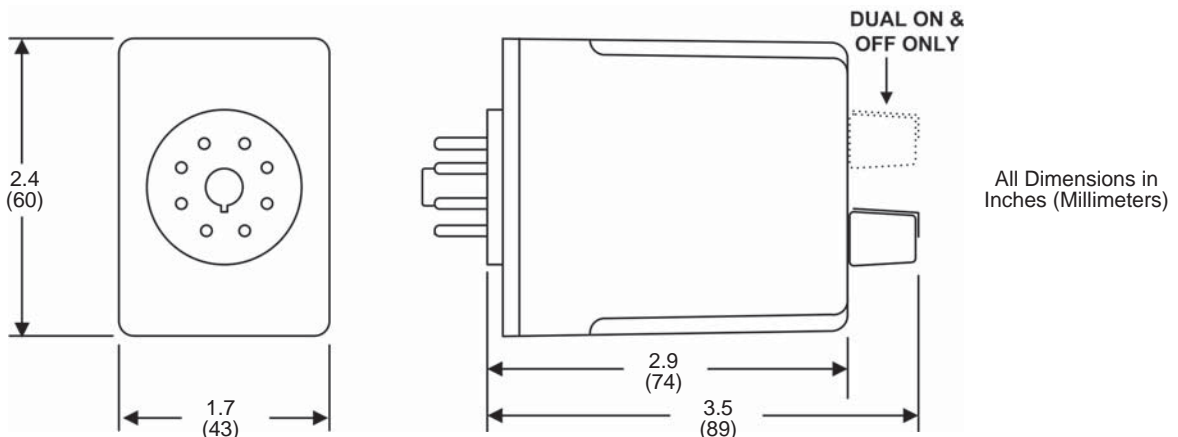

DEFINITION OF TIMING FUNCTIONS

Understanding the differences between all the functions available in time delay relays can sometimes be a daunting task. To begin with, time delay relays are simply control relays with a time delay built in. Their purpose is to control an event based on time.

Typically, time delay relays are initiated or triggered by one of two methods, depending on the function:

- ◆ application of input voltage
- ◆ application of a trigger

These triggers can be one of two signals: a control switch (dry contact), i.e., limit switch, push button, float switch, etc., or voltage (commonly known as a power trigger).

CAUTION: any time delay relay that is designed to be initiated with a dry contact control switch trigger could be damaged if voltage is applied to the trigger switch terminals. Only products that have a “power trigger” should be used with voltage as the trigger.

To help understand, some definitions are important:

- ◆ Input Voltage - control voltage applied to the input terminals. Depending on the function, input voltage will either initiate the unit or make it ready to initiate when a trigger is applied.
- ◆ Trigger- on certain timing functions, a trigger is used to initiate the unit after input voltage has been applied. As noted above, this trigger can either be a control switch (dry contact switch) or a power trigger (voltage).
- ◆ Output (Load) - every time delay relay has an output (either mechanical relay or solid state) that will open & close to control the load. Note that the user must provide the voltage to power the load being switched by the output contacts of the time delay relay. In all wiring diagrams, the output is shown in the normal de-energized position.

Below and on the following pages are both written and visual descriptions on how the common timing functions operate. A Timing Chart shows the relationship between Input Voltage, Trigger (if present) and Output. If you cannot find a product to fit your requirements or have any questions, Macromatic's Application Engineers offer technical information along with product selection and application assistance. Call us at 800-238-7474 or e-mail us tech-help@macromatic.com.

Function/Code	Operation	Timing Chart
ON DELAY Delay on Operate Delay on Make A	Upon application of input voltage, the time delay (t) begins. At the end of the time delay (t), the output is energized. Input voltage must be removed to reset the time delay relay & de-energize the output..	
INTERVAL ON Interval B	Upon application of input voltage, the output is energized and the time delay (t) begins. At the end of the time delay (t), the output is de-energized. Input voltage must be removed to reset the time delay relay.	
OFF DELAY Delay on Release Delay on Break Delay on De-Energization C	Upon application of input voltage, the time delay relay is ready to accept a trigger. When the trigger is applied, the output is energized. Upon removal of the trigger, the time delay (t) begins. At the end of the time delay (t), the output is de-energized. Any application of the trigger during the time delay will reset the time delay (t) and the output remains energized.	
SINGLE SHOT One Shot Momentary Interval D	Upon application of input voltage, the time delay relay is ready to accept a trigger. When the trigger is applied, the output is energized and the time delay (t) begins. During the time delay (t), the trigger is ignored. At the end of the time delay (t), the output is de-energized and the time delay relay is ready to accept another trigger.	

DEFINITION OF TIMING FUNCTIONS

Function/Code	Operation	Timing Chart
FLASHER (Off First) E	<p>Upon application of input voltage, the time delay (t) begins. At the end of the time delay (t), the output is energized and remains in that condition for the time delay (t). At the end of the time delay (t), the output is de-energized and the sequence repeats until input voltage is removed.</p>	
FLASHER (ON First) F	<p>Upon application of input voltage, the output is energized and the time delay (t) begins. At the end of the time delay (t), the output is de-energized and remains in that condition for the time delay (t). At the end of the time delay (t), the output is energized and the sequence repeats until input voltage is removed.</p>	
ON/OFF DELAY G	<p>Upon application of input voltage, the time delay relay is ready to accept a trigger. When the trigger is applied, the time delay (t1) begins. At the end of the time delay (t1), the output is energized. When the trigger is removed, the output contacts remain energized for the time delay (t2). At the end of the time delay (t2), the output is de-energized & the time delay relay is ready to accept another trigger. If the trigger is removed during time delay period (t1), the output will remain de-energized and time delay (t1) will reset. If the trigger is removed during time delay period (t2), the output will remain energized and the time delay (t2) will reset.</p>	
SINGLE SHOT FALLING EDGE H	<p>Upon application of input voltage, the time delay relay is ready to accept a trigger. When the trigger is applied, the output remains de-energized. Upon removal of the trigger, the output is energized and the time delay (t) begins. At the end of the time delay (t), the output is de-energized unless the trigger is removed and re-applied prior to time out (before time delay (t) elapses). Continuous cycling of the trigger at a rate faster than the time delay (t) will cause the output to remain energized indefinitely.</p>	
WATCHDOG Retriggerable Single Shot J	<p>Upon application of input voltage, the time delay relay is ready to accept a trigger. When the trigger is applied, the output is energized and the time delay (t) begins. At the end of the time delay (t), the output is de-energized unless the trigger is removed and re-applied prior to time out (before time delay (t) elapses). Continuous cycling of the trigger at a rate faster than the time delay (t) will cause the output to remain energized indefinitely.</p>	
TRIGGERED ON DELAY K	<p>Upon application of input voltage, the time delay relay is ready to accept a trigger. When the trigger is applied, the time delay (t) begins. At the end of the time delay (t), the output is energized and remains in that condition as long as either the trigger is applied or the input voltage remains. If the trigger is removed during the time delay (t), the output remains de-energized & the time delay (t) is reset.</p>	

DEFINITION OF TIMING FUNCTIONS

Function/Code	Operation	Timing Chart
REPEAT CYCLE (OFF 1st) L	Upon application of input voltage, the time delay (t1) begins. At the end of the time delay (t1), the output is energized and remains in that condition for the time delay (t2). At the end of this time delay, the output is de-energized and the sequence repeats until input voltage is removed.	
REPEAT CYCLE (ON 1st) M	Upon application of input voltage, the output is energized and the time delay (t1) begins. At the end of the time delay (t1), the output is de-energized and remains in that condition for the time delay (t2). At the end of this time delay, the output is energized and the sequence repeats until input voltage is removed.	
DELAYED INTERVAL Single Cycle N	Upon application of input voltage, the time delay (t1) begins. At the end of the time delay (t1), the output is energized and remains in that condition for the time delay (t2). At the end of this time delay (t2), the output is de-energized. Input voltage must be removed to reset the time delay relay.	
TRIGGERED DELAYED INTERVAL P	Upon application of input voltage, the time delay relay is ready to accept a trigger. When the trigger is applied, the time delay (t1) begins. At the end of the time delay (t1), the output is energized and remains in that condition for the time delay (t2). At the end of this time delay (t2), the output is de-energized & the relay is ready to accept another trigger. During both time delay (t1) & time delay (t2), the trigger is ignored.	
TRUE OFF DELAY R	Upon application of input voltage, the output is energized. When the input voltage is removed, the time delay (t) begins. At the end of the time delay (t), the output is de-energized. Input voltage must be applied for a minimum of 0.5 seconds to assure proper operation. Any application of the input voltage during the time delay (t) will reset the time delay. No external trigger is required.	
ON DELAY/ TRUE OFF DELAY S	Upon application of input voltage, the time delay (t1) begins. At the end of the time delay (t1), the output is energized. When the input voltage is removed, the output remains energized for the time delay (t2). At the end of the time delay (t2), the output is de-energized. Input voltage must be applied for a minimum of 0.5 seconds to assure proper operation. Any application of the input voltage during the time delay (t2) will keep the output energized & reset the time delay (t2). No external trigger is required.	
SINGLE SHOT-FLASHER T	Upon application of input voltage, the time delay relay is ready to accept a trigger. When the trigger is applied, the time delay (t1) begins and the output is energized for the time delay (t2). At the end of this time delay (t2), the output is de-energized and remains in that condition for the time delay (t2). At the end of the time delay (t2), the output is energized and the sequence repeats until time delay (t1) is completed. During the time delay (t1), the trigger is ignored.	
ON DELAY-FLASHER X	Upon application of input voltage, the time delay begins (t1). At the end of the time delay (t1), the output is energized and remains in that condition for the time delay (t2). At the end of this time delay (t2), the output is de-energized and remains in that condition for the time delay (t2). At the end of the time delay (t2), the output is energized and the sequence repeats until input voltage is removed.	

SOCKETS & ACCESSORIES

8 Pin Octal Socket- Surface or DIN Rail-Mounted

10A @ 600V
1 or 2 #12-22 AWG Wire
Recommended Tightening Torque
of 7 in-lbs. (12 in-lbs maximum)
Pressure Wire Clamp Terminations



File #E169693 File #LR701114

Catalog Number 70169-D

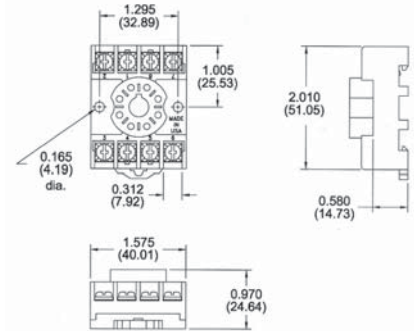

11 Pin Octal Socket- Surface or DIN Rail-Mounted

10A @ 300V
1 or 2 #12-22 AWG Wire
Recommended Tightening Torque
of 7 in-lbs. (12 in-lbs maximum)
Pressure Wire Clamp Terminations



File #E169693 File #LR701114

Catalog Number 70170-D

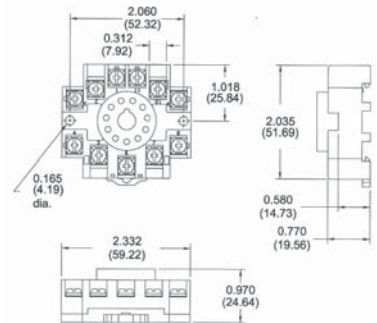

8 Pin Octal Socket- Back-Mounted

10A @ 300V
Pressure Wire Clamp Terminations



File #E62437

Catalog Number SR6P-M08G

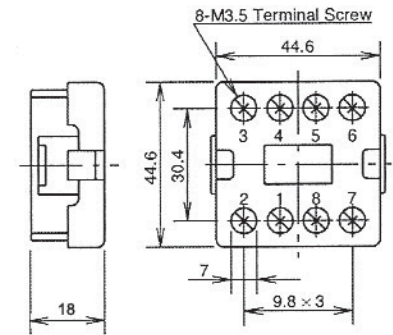

11 Pin Octal Socket- Back-Mounted

10A @ 300V
Pressure Wire Clamp Terminations



File #E62437

Catalog Number SR6P-M11G

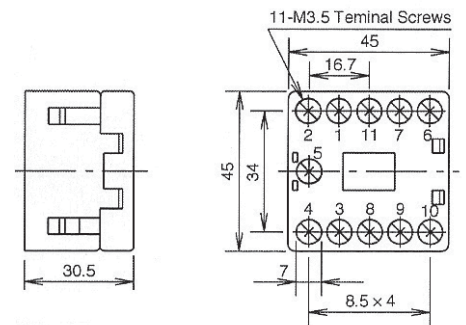

SOCKETS & ACCESSORIES

SOCKETS & ACCESSORIES

Hold Down Spring Catalog Number 70166

Can be used for:

- ◆ Panel-Mounted Sockets
 - ◆ Sockets Mounted to 35mm DIN Rail *
- * Requires two machine screws with washers & nuts-- contact Macromatic or www.macromatic.com/70166 for more information.



DIN Rail Adaptor Kit Catalog Number 70500

- Quick & Economical Way to Install Any THx Series 2" x 2" Encapsulated Time Delay Relays on 35mm DIN Rail
- ◆ Clip Comes with a Threaded Hole to Eliminate Need for a Washer & Nut
 - ◆ All Mounting Hardware Included

