

T H E R M O M E T R I C S  
A C O M M I T M E N T T O E X C E L L E N C E

# NTC Diode

## Thermometrics

### Thermistors



A range of NTC chip thermistors in DO-35 style glass package (diode outline) with axial solder-coated copper-clad steel wires.

- Designed for accurate temperature measurement, control and compensation
- Tight tolerances on resistance and B value
- Operation up to 482°F (250°C) with excellent stability
- Glass body provides hermetic seal and voltage insulation and excellent stability
- Designed for cost effective solid state sensor
- Lead-wires metallurgically bonded to thermistor element for improved reliability (Type GE only)
- Resistant to corrosive atmospheres and harsh environments
- Available on axial bandolier to IEC-286-1/EIA-468A and packet taped to EIA RS-481 for MELF.
- Also available loose-packed with axial, radial and SMD wire forms
- Suitable for automotive, telecom (battery packs), HVAC and white goods applications
- Temperature sensing for household appliances such as rice cookers, electronic ranges, ovens, etc.
- Temperature sensing for industrial products such as pharmaceuticals, chemicals, food, etc. components.

**Amphenol**  
**Advanced Sensors**

# Type DK Specifications

Chip thermistor in DO-35 glass package

## Options

- Other resistance values within the ranges shown; e.g. code DKA302\*2 for  $3000\ \Omega \pm 2\%$  at 77°F (25°C)
- Reference temperatures in the range 0°F to 302°F (-18°C to 150°C)
- Operation to 572°F (300°C) (no solder coating on wires)
- Wire lengths 0.16 in to 1.26 in (4 mm to 32 mm)  $\pm 0.04$  in ( $\pm 1$  mm) for DK-N; up to 1.02 in (26 mm) for DK-H

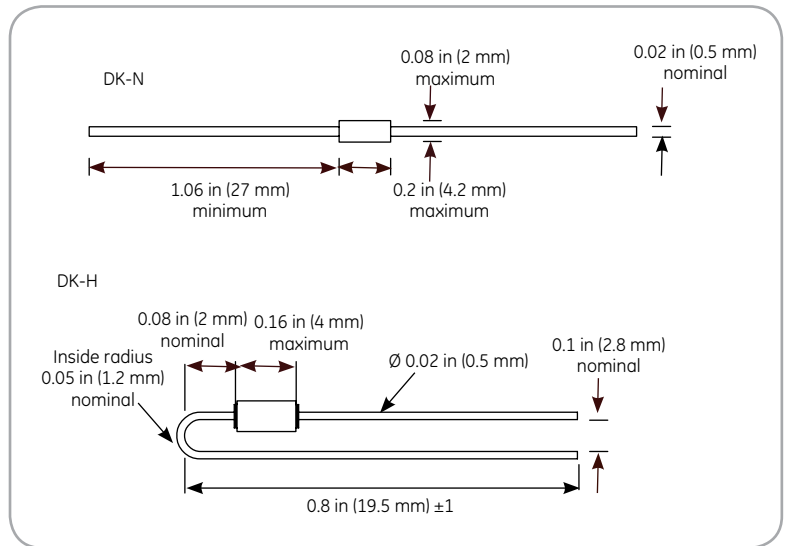

NTC Type DK wires should not be bent within 0.08 in (2 mm) of glass body

## Coding

Replace \* in the codes shown below as follows:

- Axial, loose-packed: N
- Axial, banded: B
- Radial, loose-packed: H
- Surface mount, loose-packed: M

## Data

- Operating temperature: -40°F to 482°F (-40°C to 250°C)
- Thermal time constant: 7 seconds (cooling in air)
- Dissipation factor: 3.0 mW/K
- Mass: 0.2 g
- Packing/MOQ: 1000/box (loose), 5000/reel (banded)

R25 $\Omega$	Material system	B 25/85 K	Code R25 $\pm 2\%$	Code R25 $\pm 3\%$	Code R25 $\pm 5\%$	Code R25 $\pm 10\%$
2000	2	3540 $\pm 1\%$	DKA202*2	DKA202*3	DKA202*5	DKA202*10
5000	2	3540 $\pm 1\%$	DKA502*2	DKA502*3	DKA502*5	DKA502*10
10,000	2	3540 $\pm 1\%$	DKA103*2	DKA103*3	DKA103*5	DKA103*10
10,000	5A	3730 $\pm 2\%$		DKC103*3	DKC103*5	DKC103*10
12,000	5A	3730 $\pm 2\%$	DKC123*2	DKC123*3	DKC123*5	DKC123*10
10,000	3	3960 $\pm 1\%$	DKF103*2	DKF103*3	DKF103*5	DKF103*10
20,000	3	3960 $\pm 1\%$	DKF203*2	DKF203*3	DKF203*5	DKF203*10
30,000	3	3960 $\pm 1\%$	DKF303*2	DKF303*3	DKF303*5	DKF303*10
50,000	3	3960 $\pm 1\%$	DKF503*2	DKF503*3	DKF503*5	DKF503*10
100,000	3	3960 $\pm 1\%$	DKF104*2	DKF104*3	DKF104*5	DKF104*10
200,000	G	4263 $\pm 2\%$			DKG204*5	DKG204*10
500,000	D	4573 $\pm 2\%$			DKD504*5	DKD504*10
1,000,000	D	4573 $\pm 2\%$			DKD105*5	DKD105*10

See separate tables for resistance-temperature data.  
Consult factory for additional tolerance requirements.

# Type DKM Specifications

Glass encapsulated SMD thermistor

## Description

A range of thermistors in DO-35 style glass package (diode outline formed for surface lead-wires and applications) with solder-coated copper-clad steel lead-wires.

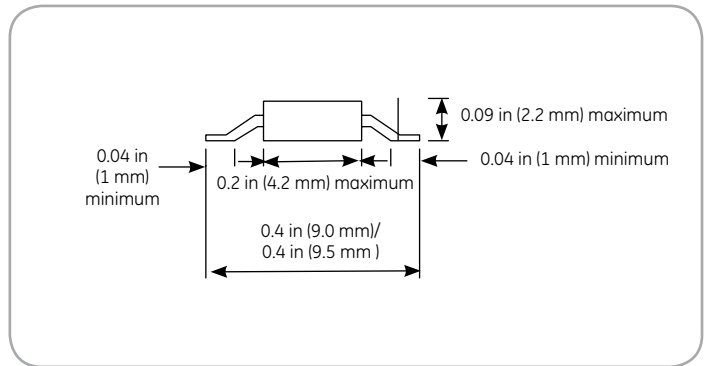

NTC Type DKM wires should not be bent within 0.08 in (2 mm) of glass body

## Options

- Other resistance values within the ranges shown; e.g. code DKA302M2 for  $3000 \Omega \pm 2\%$  at 77°F (25°C)
- Reference temperatures in the range 32°F to 302°F (0°C to 150°C)
- For tape and reel, add suffix "AB"
- Operation to 572°F (300°C); no solder coating on lead-wires

## Data

- Operating temperature: -40°F to 482°F (-40°C to 250°C)
- Thermal time constant: 7 seconds (cooling in air)
- Dissipation factor: 3.0 mW/K
- Mass: 0.2 g
- Packing/MOQ: 1000/box (loose)

R25 $\Omega$	Material System	B 25/85 K	Code R25 $\pm 2\%$	Code R25 $\pm 3\%$	Code R25 $\pm 5\%$	Code R25 $\pm 10\%$
2000	2	3540 $\pm 1\%$	DKA202M2	DKA202M3	DKA202M*5	DKA202M10
5000	2	3540 $\pm 1\%$	DKA502M*2	DKA502M3	DKA502M5	DKA502M10
10,000	2	3540 $\pm 1\%$	DKA103M2	DKA103M3	DKA103M5	DKA103M10
10,000	5A	3730 $\pm 2\%$		DKC103M3	DKC103M5	DKC103M10
10,000	3	3960 $\pm 1\%$	DKF103M2	DKF103M3	DKF103M5	DKF103M10
20,000	3	3960 $\pm 1\%$	DKF203M2	DKF203M3	DKF203M5	DKF203M10
30,000	3	3960 $\pm 1\%$	DKF303M2	DKF303M3	DKF303M5	DKF303M10
50,000	3	3960 $\pm 1\%$	DKF503M2	DKF503M3	DKF503M5	DKF503M10
100,000	3	3960 $\pm 1\%$	DKF104M2	DKF104M3	DKF104M5	DKF104M10
200,000	G	4263 $\pm 2\%$			DKG204M5	DKG204M10
500,000	D	4573 $\pm 2\%$			DKD504M5	DKD504M10
1,000,000	D	4573 $\pm 2\%$			DKD105M5	DKD105M10

See separate tables for resistance-temperature data..  
Consult factory for additional tolerance requirements.

# Type GE Specifications

Glass encapsulated DO-35 package

## Options

- For reel taping "R" suffix
- Nickel leads for welding
- Other resistances in the range 250 Ω to 5 MΩ
- Other tolerances, tolerances at other temperatures
- Alternative leads lengths, lead materials
- Can be expanded to 572°F (300°C) with nickel leads

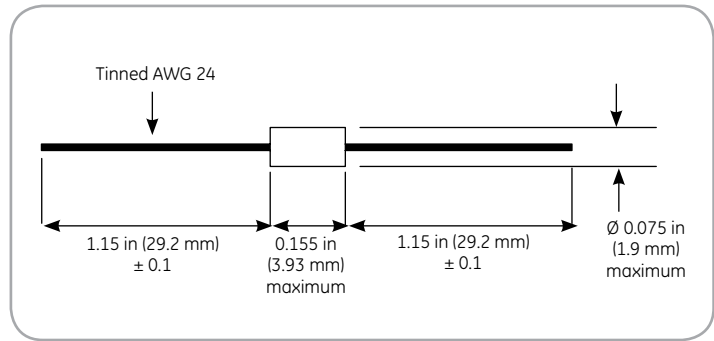

NTC Type GE dimensions

## Data

- Standard resistance tolerance: ±10% @ 77°F (25°C)
- Dissipation constant: 3.0 mW/K
- Time constant: 7 seconds
- Operating range: -58°F to 400°F (-50°C to 204°C)

Ro@25° C (Ω)	Material System	Beta 25/85	Type Number
250	GE5.5*	2983	AL03006-165.9-55-K
500	GE5.5*	2983	AL03006-331.8-55-K
1K	GE7.3	3499	AL03006-624-73-K
2K	GE7.3	3499	AL03006-1248-73-K
2786	GE10.1	4102	AL03006-1576-101-K
3K	GE7.6	3553	AL03006-1847-76-K
4K	GE7.6	3553	AL03006-2463-76-K
5K	GE7.6	3553	AL03006-3079-76-K
10K	GE9.7A	3992	AL03006-5818-97-K
20K	GE9.8	3974	AL03006-11.7K-98-K
30K	GE9.8	3974	AL03006-17.53K-98-K
50K	GE9.7B	3952	AL03006-29.1K-97-K
100K	GE9.7B	3952	AL03006-58.2K-97-K
200K	GE12.3	4365	AL03006-111.3K-123-K
500K	GE13.8	4567	AL03006-269.8K-138-K
1M	GE14.5	4661	AL03006-535K-145-K
5M	GE16.4	4848	AL03006-2.6M-164-K

\*maximum operating temperature 302°F (150°C)

# Type MELF Specifications

Glass encapsulated SMD thermistor

## Description

Hermetically sealed, glass encapsulated thermistor in SOD-80 SMD package.

## Options

- For  $\pm 5\%$  @ 77°F (25°C), replace "K" with "J"
- For  $\pm 3\%$  @ 77°F (25°C), replace "K" with "H"
- For  $\pm 2\%$  @ 77°F (25°C), replace "K" with "G"
- For reel taping add "R" suffix
- Other resistances in the range 250  $\Omega$  to 5 M $\Omega$  available
- Other tolerances, tolerances at other temperatures

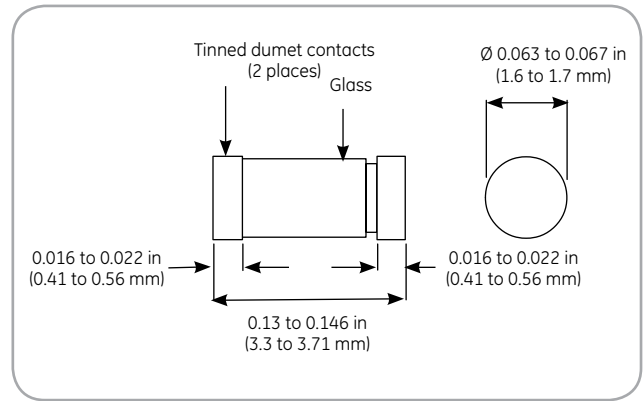

NTC Type MELF dimensions

## Data

- Standard resistance tolerance:  $\pm 10\%$  @ 77°F (25°C)
- Dissipation constant: 3.0 mW/°C
- Time constant: 7 seconds
- Operating range: -58°F to 400°F (-50°C to 204°C)

Ro@25° C ( $\Omega$ )	Material System	Beta 25/85	Type Number
250	GE5.5*	2983	03006-165.9-55-K
500	GE5.5*	2983	03006-331.8-55-K
1K	GE7.3	3499	03006-624-73-K
2K	GE7.3	3499	03006-1248-73-K
2786	GE10.1	4102	03006-1576-101-K
3K	GE7.6	3553	03006-1847-76-K
4K	GE7.6	3553	03006-2463-76-K
5K	GE7.6	3553	03006-3079-76-K
10K	GE9.7A	3992	03006-5818-97-K
20K	GE9.8	3974	03006-11.7K-98-K
30K	GE9.8	3974	03006-17.53K-98-K
50K	GE9.7B	3952	03006-29.1K-97-K
100K	GE9.7B	3952	03006-58.2-97-K
200K	GE12.3	4365	03006-111.3K-123-K
500K	GE13.8	4567	03006-269.8K-138-K
1M	GE14.5	4661	03006-535K-145-K
5M	GE16.4	4848	03006-2.6M-164-K

\*maximum operating temperature 302°F (150°C)

# Type TH Specifications

Glass encapsulated radial lead thermistor

Part Number	Resistance (25 Ω)	β Constant (25/50)	Recommended Maximum Operating Current at 77°F (25°C)	Maximum Permissible Current at 77°F (25°C)
TH220J33G	2.0 K	3375 K	0.22 mA	30.0 mA
TH225J13G	2.545 K	3745 K	0.22 mA	30.0 mA
TH238J34G	3.896 K	3434 K	0.20 mA	26.5 mA
TH253J34G	5.369 K	3434 K	0.16 mA	24.0 mA
TH310J34G	10.74 K	3434 K	0.13 mA	20.0 mA
TH310J36G	10.0 K	3684 K	0.14 mA	20.0 mA
TH310J39G	10.0 K	3933 K	0.14 mA	20.0 mA
TH315J39G	15.0 K	3933 K	0.12 mA	17.0 mA
TH320J39G	20.0 K	3952 K	0.10 mA	15.0 mA
TH349J39G	49.12 K	3952 K	0.06 mA	10.0 mA
TH350J39G	50.0 K	3952 K	0.06 mA	10.0 mA
TH398J40G	98.63 K	4014 K	0.045 mA	5.0 mA
TH410J40G	100.0 K	4014 K	0.045 mA	5.0 mA
TH420J34G	200.0 K	3450 K	0.015 mA	3.5 mA
TH423J41G	231.4 K	4176 K	0.015 mA	3.5 mA
TH510J44G	1,000 K	4491 K	0.007 mA	1.5 mA
TH513J44G	1,388 K	4491 K	0.005 mA	1.0 mA

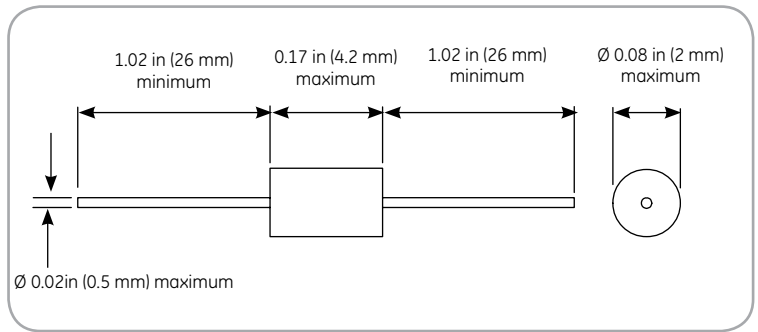

NTC Type TH dimensions

- The tolerance of resistance is  $\pm 5\%$  for standard device.
- The tolerance of B constant is  $\pm 2\%$  for standard device. The constant is determined by the equation:  

$$B = 3853.9 \ln (R_{25}/R_{50})$$
 R25 and R50 represent the thermistor resistance at 77°F and 122°F (25°C and 50°C) respectively.
- Others: For non-standard devices, consult Thermometrics.

Dissipation Factor (in still air)	Time Constant (in still air)	Operating Temperature Range	Rated Power at 77°F (25°C)
2.0 (mW/°C)	25 (seconds)	-40°F to 482°F (-40°C to 250°C)	25 mW



