

QorIQ Multicore Processor Development

QorIQ T4240 Reference Design Board



Overview

The QorIQ T4240 reference design board (T4240RDB) is a compact (1U), highly integrated board featuring the 24-virtual-core T4240 device. With its 1.67 GHz T4240 processor and rich input/output (I/O) mix, the board is designed for evaluating the T4240, T4160, and T4080 processors in networking, telecom/datacom, wireless infrastructure and military/aerospace applications. The T4 processor family can be used for combined control, data path and application layer processing in routers, switches, gateways and general-purpose embedded computing systems.

T4240RDB Block Diagram

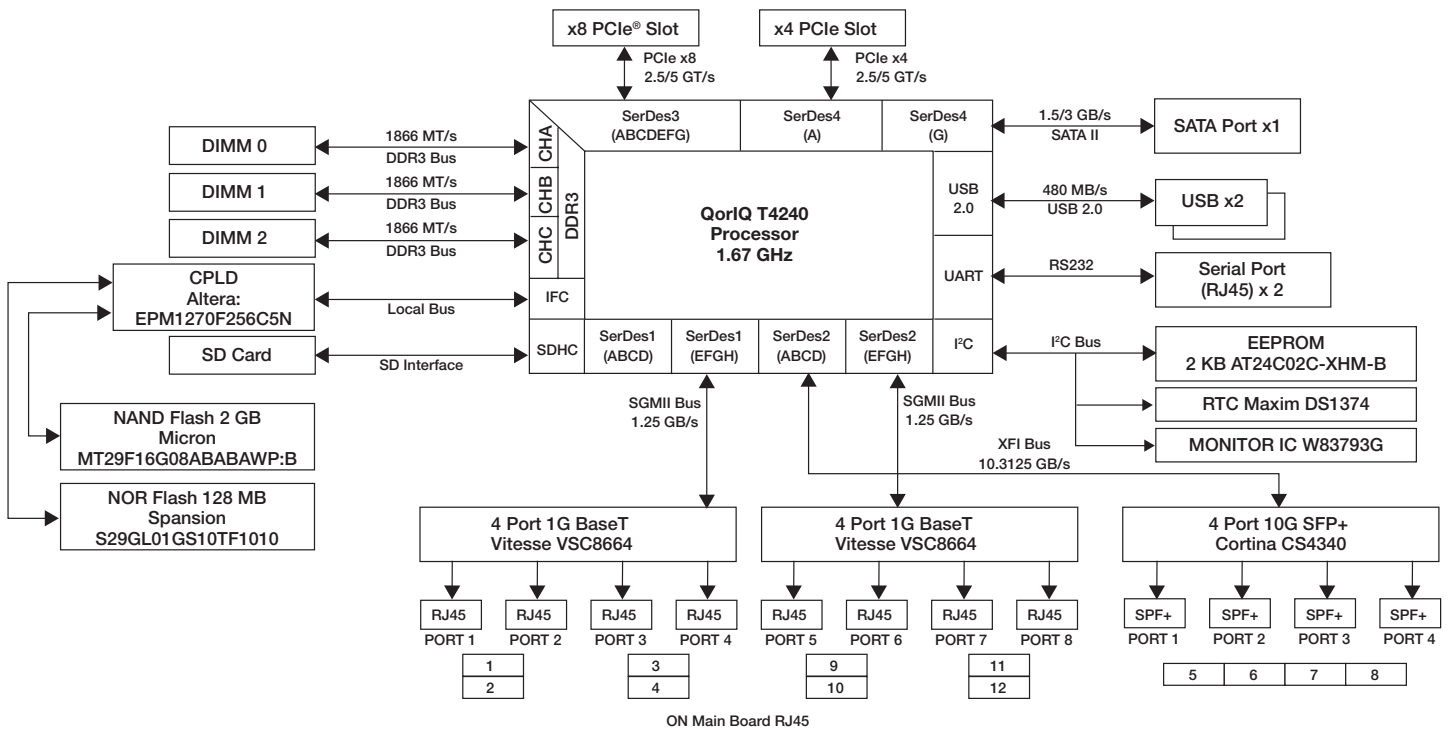

QorIQ T4240RDB Board Features

Processor

- QorIQ T4240 processor, 1.67 GHz core with 1866 MT/s DDR3 data rate
- Multiple SysClk inputs for generating various device frequencies

Memory

- Three unbuffered DDR3 240-pin uDIMM modules with ECC (72-bit bus), 6 GB memory, 1866 MT/s data rate
- 128 MB NOR flash, 16-bit
- 2 GB SLC NAND flash
- 2 KB 24C02 I²C EEPROM
- SD connector to interface

PCI Express®

- PCIe x4 connector
- PCIe x8 connector

USB 2.0

- Dual Type-A USB slot, connected to USB PHY

Ethernet

- Four 10 GB/s SFP+ ports
- LAN1–LAN8: Connected to SGMII PHY-VSC8664

Others

- LEDs for power and Ethernet link and active
- JTAG for debugging
- I²C
 - Serial EEPROM: Board identification
 - Real-time clock
- ATX power supply

The T4240RDB supports two PCI Express® slots, as well as an SD/MMC card slot and two USB 2.0 receptacles. These components, integrated with the T4 family, provide an application-specific platform that can help you get a jump start on your next design. The T4240RDB memory supports 6 GB of DDR3 at 1866 MHz, 128 MB of NOR flash, a 2 GB NAND flash and a 2 KB I²C EEPROM.

The T4240RDB is pre-loaded with the Embedded Linux® Essentials for QorIQ processors with data path acceleration software development kit. This kit includes a 64-bit SMP Linux kernel, hugetlbfs for applications with a large memory footprint, user space Data Path Acceleration Architecture (DPAA) for high-performance packet handling, u-boot, the GCC tool chain and virtualization support, among many other features. This board is also available from Nexcom in production volumes. For more information, visit nexcom.com/#QorIQ.

About the T4 Processor

The T4240 processor contains the e6500 core, built on Power Architecture® technology, offering speeds of 1500–1800 MHz. It has a three-level cache hierarchy with 32 KB of instruction and data cache per core, 6 MB L2 cache clustered in banks of four cores allowing efficient sharing of code and data within a multicore cluster, and a 1.5 MB CoreNet platform cache. I/O includes 32 SerDes lanes running at up to 10 GHz, multiplexed across four PCI Express controllers (up to two at Gen3), up to four 10 Gigabit Ethernet interfaces (XFI, XAUI, 10Gbase-KR or HiGig), up to 16 1 Gigabit Ethernet interfaces (SGMII and RGMII), two Serial RapidIO® 2.0 controllers and two SATA 2.0 interfaces.

The T4240 processor supports three 64-bit DDR3 and DDR3L (low power) SDRAM memory controllers with ECC support running at up to 1867 MHz data rate. It includes two USB 2.0 interfaces (including PHY), an SD/MMC interface, a NOR/NAND controller, four I²C and SPI. It also includes the accelerator blocks collectively known as the DPAA that offload various tasks from the core, including routine packet handling, security algorithm calculations, compression, decompression and pattern matching. In addition, each e6500 core implements the Freescale Altivec technology SIMD engine, which achieves DSP-like performance for math-intensive applications.

In addition to the 24-threaded T4240 processor, the QorIQ T4 family also includes the 16-threaded T4160 and the 8-threaded T4080 processors. These three family members offer a performance scaling factor of 3x within a pin compatible package. The T4240RDB can be configured to look like a T4160 or T4080 reference design board.



For more information, visit freescale.com/QorIQ

Freescale, the Freescale logo, Altivec and QorIQ are trademarks of Freescale Semiconductor, Inc., Reg. U.S. Pat. & Tm. Off. CoreNet is a trademark of Freescale Semiconductor, Inc. All other product or service names are the property of their respective owners. The Power Architecture and Power.org word marks and the Power and Power.org logos and related marks are trademarks and service marks licensed by Power.org. © 2013, 2014 Freescale Semiconductor, Inc.

Document Number: T4240RDBFS REV 1

