



4-Channel Analog Video Decoders and Analog Video Encoder for Automotive Applications

TW9966

The TW9966 includes four high quality NTSC/PAL/SECAM video decoders that convert analog composite video signal to digital component YCbCr data for automotive applications. Each channel contains a 10-bit ADC and proprietary clamp and gain controllers and utilizes a 4H comb filter for separating luminance and chrominance to reduce cross noise artifacts. The TW9966 adopts the image enhancement techniques, such as IF compensation filter, CTI and programmable peaking. TW9966 also includes one NTSC/PAL video encoder with two 10-bit DAC's to support CVBS and YC output. The TW9966 also includes audio CODEC, which has five audio Analog-to-Digital converters and one Digital-to-Analog converter. A built-in audio controller can generate digital outputs for recording/mixing and accepts digital input for playback.

Features

- Accepts all NTSC(M/4.43) / PAL(B/D/G/H/I/K/L/M/N/60)/SECAM standards with auto detection
- Integrated four video analog anti-aliasing filters and 10-bit CMOS ADCs
- High performance adaptive 4H comb filters for all NTSC/PAL standards
- IF compensation filter for improvement of color demodulation
- Color Transient Improvement (CTI)
- Automatic white peak control
- Programmable hue, saturation, contrast, brightness and sharpness
- Proprietary fast video locking system for non-real-time application
- Supports the standard ITU-R BT.656 format or time multiplexed output with 54/108MHz
- Provides simultaneous four channel Full D1 and CIF time-multiplexed outputs with 54MHz
- Integrated five audio ADCs and one audio DAC
- Provides multi-channel audio mixed analog output
- Supports I2S/DSP Master/Slave interface for record output and playback input
- PCM 8/16 bit and u-Law/A-Law 8-bit for audio word length
- Programmable audio sample rate that covers popular frequencies of 8/16/32/44.1/48kHz
- Supports a two-wire serial host interface
- Integrated one video encoder and two 10-bit video CMOS DACs
- Integrated clock PLL for 108MHz clock output
- Ultra low power consumption (Typical 666.84mW)
- Automotive Grade
- 128 pin LQFP package

Block Diagram

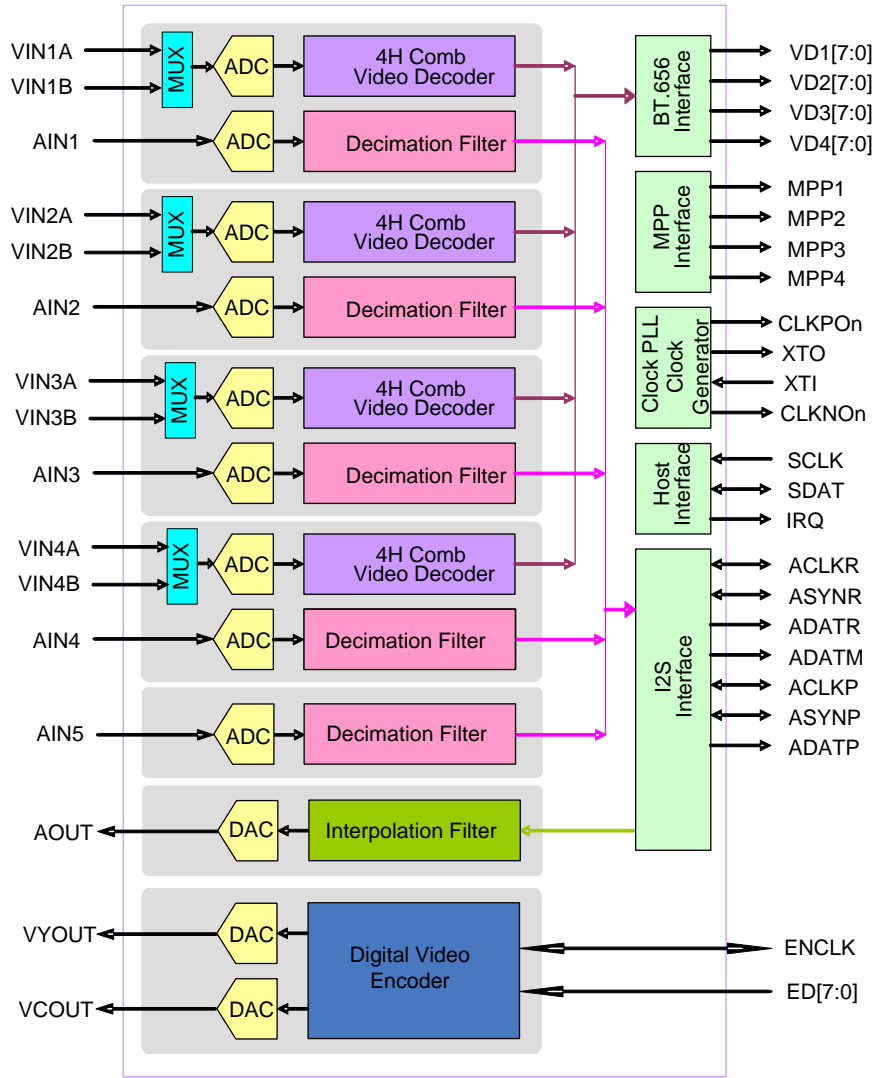

For additional products, see www.intersil.com/product_tree

Intersil Automotive Qualified products are manufactured, assembled and tested utilizing TS16949 quality systems as noted in the quality certifications found at www.intersil.com/design/quality

Intersil products are sold by description only. Intersil Corporation reserves the right to make changes in circuit design, software and/or specifications at any time without notice. Accordingly, the reader is cautioned to verify that data sheets are current before placing orders. Information furnished by Intersil is believed to be accurate and reliable. However, no responsibility is assumed by Intersil or its subsidiaries for its use; nor for any infringements of patents or other rights of third parties which may result from its use. No license is granted by implication or otherwise under any patent or patent rights of Intersil or its subsidiaries.