

92mm sq.

San Ace 92W

- 25mm thick (9WL type)
- 25mm thick (9WS type)
- 25mm thick (9WP type)
- 38mm thick (9VV type)



Model no. 9WP0912S401, 9WP0912F401, 9WP0924S401 are not certified.

General Specifications

- Material: Frame: Plastics (Flammability: UL94V-0), Impeller: Plastics (Flammability: UL94V-0)
- Expected Life: Refer to specifications (Indoor, L10:Survival rate: 90% at 60°C, rated voltage, and continuously run in a free air state)
- Lead Wire: ⊕red ⊖black or blue (Sensor) yellow
- Storage Temperature: -30°C to +70°C (Non-condensing)

92×92×25mm (Mass : 120g) **IP 68** **9WP type**

Specifications

The following nos. have pulse sensors and ribs.

Model No.	Rated Voltage [V]	Operating Voltage Range [V]	Rated Current [A]	Rated Input [W]	Rated Speed [min ⁻¹]	Max. Airflow [m ³ /min] [CFM]	Max. Static Pressure [Pa] [inchH ₂ O]	SPL [dB(A)]	Operating Temperature [°C]	Expected Life [h]
9WP0912S401	12	6 to 13.8	0.27	3.24	3,550	1.66 58.6	57.7 0.231	39	-20 to +70	40,000
9WP0912F401			0.14	1.68	2,650	1.24 43.8	32.2 0.129	30		
9WP0924G401			0.19	4.56	3,900	1.76 62.2	66.5 0.267	43		
9WP0924S401	24	12 to 27.6	0.15	3.6	3,550	1.66 58.6	57.7 0.231	39		
9WP0924H401			0.1	2.4	3,150	1.45 51.2	44 0.177	33		
9WP0924F401			0.08	1.92	2,650	1.24 43.8	32.2 0.129	30		
9WP0924B401			0.05	1.20	2,000	0.90 31.8	18.0 0.072	23	-10 to +70	

Some models can also be equipped without sensors as an option. Please refer to the index (pp. 417 to 437).

Dimensions (unit : mm)

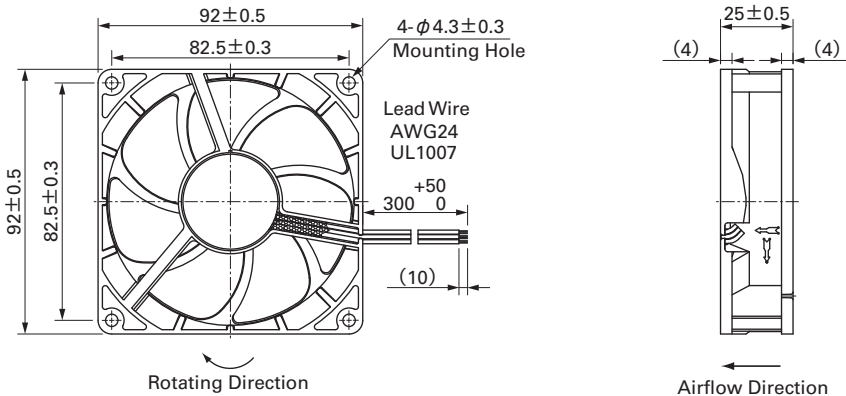

Options (unit : mm)

Finger Guards

Model : 109-099C Surface treatment : Nickel-chrome plating (silver) Color : Nickel-chrome plating (silver)

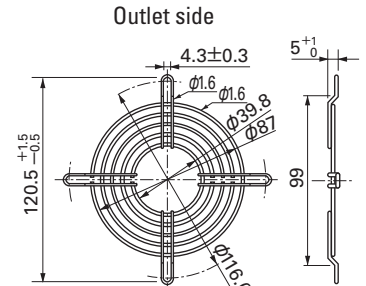

Mass : 22g

Model : 109-099E Surface treatment : Nickel-chrome plating (silver) Color : Nickel-chrome plating (silver)
: 109-099H : Cation electropainting (black)

Reference Dimension of Mounting Holes and Vent Opening (unit : mm)

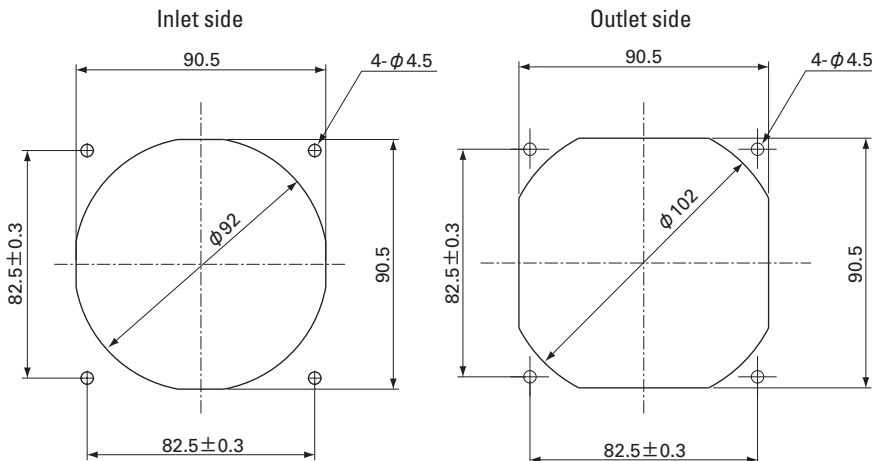

Inlet side, Outlet side

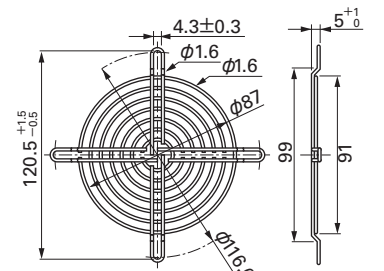

Mass : 29g