



New PAN1740 Series Place and Play *Bluetooth*® Low Energy Module



Revolutionizing Bluetooth Low Energy with a 5mA Current Consumption in Tx or Rx!

A revolution is underway in Bluetooth Low Energy to dramatically shrink power budgets for battery powered applications. Panasonic's "nanopower" family of 2nd generation BLE modules reduces transmit and receive current consumption by more than 66% when compared to the current generation of BLE devices and nearly a 90% reduction from Bluetooth Classic devices. Most significant is that these current reductions have been achieved without range reduction, without Tx power reduction and without changes to the Bluetooth specification.

The **PAN1740 Series** is Panasonic's next generation "nanopower" Bluetooth Low Energy module with reduced form factor, significantly lower power consumption, embedded BLE stack and profile. Panasonic cost engineering lowers component count and the application BOM. This single mode Bluetooth system-on-chip module is optimized for low power and small size. The power consumption of only 5mA in Tx or Rx mode allows for the use of coin cell batteries and reduces battery requirements up to 50% when compared to current generation BLE devices. With a fully shielded case, integrated crystal oscillators and chip antenna, the 9.0 x 9.5 x 1.8 mm footprint of the **PAN1740 Series** makes it one of the smallest BLE modules available. The **PAN1740 Series** is qualified to the Bluetooth 4.0 standard – FCC, IC, CE certifications are pending. Panasonic's designer friendly Easy-to-Use (ETU) development kits reduce design efforts and critical time to market.

Features

- Bluetooth Smart® Module
- Tx Current @ 0dBm: 5mA
- Small Footprint: 9 x 9.5 x 1.8mm
- High Sensitivity: -93dbm typ.
- Output Power Up to 0dbm
- Embedded BLE Stack and GATT Profile
- Industrial Temperature Range: -40 to 85°C
- Two Internal Crystal Oscillators
- Integrated Antenna

Applications

- Consumer Electronics
- Wireless Sensors
- Cable Replacement
- Instrumentation
- Heart Rate Monitors
- Blood Glucose Meters

Technical Characteristics

Parameter	Value	Condition
Receiver Sensitivity	-93 dBm typ.	Ideal Signal
Output Power	+0 dBm typ.	@ 50 Ohm Antenna Pin
Power Supply	2.35 to 3.3 V	Single Voltage Operation
Transmit	4.9 mA	GFSK
Receive	4.9 mA	GFSK
Operating Temperature	-40 to +85°C	

Block Diagram (PAN1740)

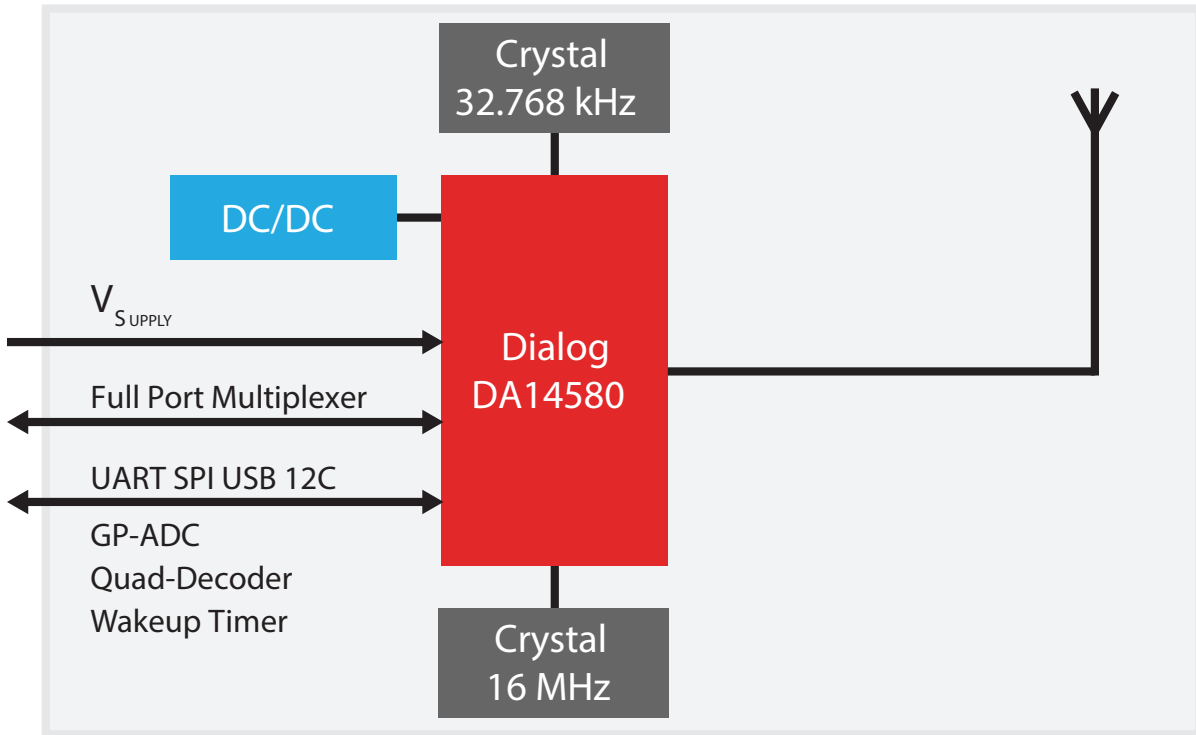

Ordering Information

Part Number	Description
ENW89846A1KF	PAN1740 <i>Bluetooth</i> Low Energy Module, Integrated Antenna
PAN1740-KIT	PAN1740 Evaluation Kit, Two USB Development Modules

Additional Information

For more information on the PAN1740 Bluetooth Low Energy Module, visit our blog by clicking on the link below. There, you can download our new whitepaper, entitled "Moving Forward With Bluetooth Low Energy".

<http://www.pidtechinsights.com/2014/03/11/moving-forward-with-bluetooth-low-energy/>