

Keysight N6780 Series Source/Measure Units (SMUs) for the N6700 Modular Power System

N6781A 2-Quadrant Source/Measure Unit for Battery Drain Analysis (20 W)

N6782A 2-Quadrant Source/Measure Unit for Functional Test (20 W)

N6784A 4-Quadrant General Purpose Source/Measure Unit (20 W)

N6785A 2-Quadrant Source/Measure Unit for Battery Drain Analysis (80 W) **NEW**

N6786A 2-Quadrant Source/Measure Unit for Functional Test (80 W) **NEW**

Deliver exceptional battery life

Only Keysight's N6780 Series SMUs let you visualize current drain from nA to A in one pass and one picture unlocking insights to deliver exceptional battery life

Data Sheet



Deliver exceptional battery life

For many years, the trend in the consumer electronics market has been to make an increasing number of devices integrated and portable. As a result, smartphones, “phablets,” eBook readers, tablets, and MP3 players with multiple functions and features have emerged. Over the past few years, these devices have and continue to grow in size and power consumption. Aside from functionality and features, battery life has become the single-most critical factor to product differentiation and customer satisfaction.

Only Keysight’s N6780 Series SMUs let you visualize current drain from nA to A in one pass and one picture unlocking insights to deliver exceptional battery life.

Key Features

- Exceptional sourcing: Accurately emulate a battery
 - Stable, glitch-free sourcing and sinking (charge/eLoad), just like a battery
 - Programmable output resistance mimics the battery’s internal resistance
- Exceptional measurement: Make measurements you didn’t think were possible
 - Characterize your device’s off-, sleep-, and transmit-mode current in one pass and one picture with Keysight’s exclusive, patented seamless measurement ranging technology - no need to make multiple measurement sweeps
 - Perform battery rundown tests and characterize how your device performs with an actual battery with the SMU’s ammeter (zero-burden current shunt) mode
- Exceptional Analysis: See your device’s power consumption like never before
 - Built-in digitizer measures and logs voltage, current, and power every ~5 us (~200 kHz)
 - 14585A software provides scope, data logger, and CCDF functionality to see and analyze short- and long-term power usage

Keysight patented feature: Seamless Dynamic Measurements

N6781A, N6782A, N6785A, and N6786A

Measuring static current accurately can be a challenge. Measuring dynamic currents from nA to A is an even greater challenge. Depending on the level of current, a different precision measurement resistor must be used, representing a measurement range in the power supply.

The N6781A, N6782A, N6785A, and N6786A have multiple current measurement ranges making them tuned to measure the different operating states of a device; off-, sleep-, standby-, and transmit-mode. In addition, the top three ranges support a Keysight Technologies, Inc. exclusive feature called “seamless measurement ranging.” When you enable this feature, as the current drawn by the device under test (DUT) changes, the SMU automatically and instantaneously detects which current measurement range will return the most precise measurement and changes to that range seamlessly. When combined with the SMU’s built-in 18-bit digitizer, seamless measurement ranging enables unprecedented effective vertical resolution of ~28-bits. This provides unrivaled productivity gains and insights into power consumption never possible before. Only Keysight’s N6780 Series SMUs let you visualize current drain from nA to A in one pass and one picture unlocking insights to deliver exceptional battery life

The N6784A also has multiple measurement ranges, but does not support seamless measurement ranging.

14585A Control and Analysis Software

The software for the DC power analyzer compliments the front panel of the N6705 mainframe, offering advanced functionality and PC control. It is a flexible R&D tool for any application. It can control any of the N6700 family’s over 30 DC power modules when installed in a N6705 mainframe. When used to control an N6781A or N6785A SMU, it can be used for advanced battery drain analysis applications.

Key features

- Compliments the N6705 DC power analyzer’s front panel controls.
- Control and analyze data from up to four N6705 DC power analyzer mainframes and any installed modules at once – that’s up to 16 power supplies simultaneously.
- Easily create complex waveforms to stimulate or load down a DUT by inputting a formula, choosing from built-in, or importing waveform data.
- Enhanced control and analysis of data with familiar PC controls and large display.

www.keysight.com/find/14585

Applications

- N6781A and N6785A SMUs are tuned for battery drain analysis of any and all battery-powered devices from 20 W to 80 W, including e-Book readers, MP3 players, wireless mice, mobile phones, large smartphone “phablets,” tablets, and military radios.
- N6782A and N6786A SMUs are tuned for functional tests of devices such as DC/DC converters, PMUs, PMICs, and power amplifiers from 20 W to 80 W.
- N6784A SMU is designed to be a versatile tool for general-purpose applications in automated test systems or on an R&D bench.
- 14585A software compliments the N6781A and N6785A SMUs when used with the N6705 DC power analyzer by adding advanced battery drain functionality such as statistical analysis. However, it is also useful as a generic R&D power analysis tool since any of the over 30 other N6700 Series DC power modules can be controlled by the software when installed in an N6705 mainframe

N6781A and N6785A are SMU tuned for battery drain analysis

Unlike any other product available today, the N6781A and N6785A offer the features necessary to accurately capture the power consumption of portable, battery-powered devices from 20 W to 80 W. When used with the Keysight 14585A software, the N6781A and N6785A become an even more powerful battery drain analysis solution offering even further insights into your measurements. Whether the DUT is an e-Book reader, MP3 player, mobile phone, “phablet,” tablet, or pacemaker, the N6781A and N6785A’s seamless measurement ranging, programmable output resistance, and auxiliary DVM combine to be the only solution on the market that helps you deliver exceptional battery life.

- Deliver exceptional battery life with insight into your device’s power consumption you can get nowhere else
- Measure all modes of operation simultaneously, no need to change measurement ranges with seamless, dynamic measurements down to nA and μV
- More accurately emulate performance of a battery with internal resistance of a battery using the programmable output resistance of the N6781A and N6785A.
- Perform tests with the actual battery – monitor your battery’s voltage with the built-in auxiliary voltage measurement system while using the SMU’s ammeter mode (zero-burden current shunt) to perform real-world battery rundown tests
- Easily make sense of your measurements – scope, data logger, and complementary cumulative distribution function (CCDF) statistical analysis all help you understand what you’ve measured

N6782A and N6786A are ideal for advanced functional test

The ability to modulate the output up to 100 kHz along with 2-quadrant operation makes the N6782A, N6786A a perfect fit for advanced functional test of a variety of devices such as DC/DC converters, power management units, power amplifiers, and power management ICs (PMICs) from 20 W to 80 W.

- Stimulate the input stage of your DUT with fast sourcing and waveforms up to 100 kHz using the advanced arbitrary waveform generation feature.
- The output stage can be loaded down and measured with the electronic load capabilities of the N6782A and N6786A, providing a total test solution

N6784A SMU is the ideal general-purpose tool

General-purpose applications can span many different industries and many different devices under test. The N6784A SMU's glitch-free operation ensures safe usage with the DUT during output and measurement range changes, even with capacitances of up to 150 μ F. This enables use with a wide variety of DUTs. Its 4-quadrant operation enables it to act as a bipolar power supply or a bipolar electronic load, for added versatility.

Key features

- Glitch-free operation ensures that during programmed output or measurement ranges changes, the N6784A's output voltage and current remain steady and the DUT remains damage-free.
- Four current programming ranges (3 A, 300 mA, 100 mA, and 10 mA) enables the N6784A to be a precise current source or electronic load down to μ A.

Emulation modes to enhance usability

All of the N6780 Series SMUs have user-selectable emulation modes to improve usability and productivity by instantly configuring the SMU for the most common use cases. When one of the emulation modes is selected, the SMU optimizes all of its features and settings for that particular use case.

Emulation modes

- 4-quadrant power supply (N6784A only)
- 2-quadrant power supply
- Unipolar power supply (i.e. 1-quadrant)
- CC load
- CV load
- Voltage measure (i.e. voltmeter mode)
- Current measure (i.e. ammeter mode)
- Battery emulator (N6781A and N6785A only)
- Battery charger (N6781A and N6785A only)

www.keysight.com/find/n6781

www.keysight.com/find/n6782

www.keysight.com/find/n6784

www.keysight.com/find/n6785

www.keysight.com/find/n6786

N6781A/82A/84A Performance Specifications

This is an abbreviated list of specifications and characteristics. For the full list of specifications and characteristics, please see Chapter 5 in the Keysight N6700 Series Power Modules Specifications Guide, literature number N6700-90001 (<http://literature.cdn.keysight.com/litweb/pdf/N6700-90001.pdf>)

	N6781A, N6782A	N6784A	N6785A, N6786A
DC output ratings:			
Voltage	+ 20 V/6V	20 V / 6 V	20 V/15 V/10 V/6 V
Current (derated 1% per °C above 30°C)	±1A/± 3 A	± 1 A / ±3 A	±4 A/±5 A/±6.7 A/±8 A
Power	20 W	20 W	80 W
Output voltage ripple & noise (PAR): (from 20 Hz – 20 MHz, at full load)			
CV peak-to-peak	12 mV	12 mV	15 mV
CV rms	1.2 mV	1.2 mV	1.5 mV
Load effect (load regulation): (For any load change, based on a load lead drop 1.0 V. The load lead drop reduces the maximum available voltage at the load.)			
Voltage, 20 V, 15 V, 10 V, & 6 V ranges	700 µV, N/A, N/A, 400 µV	700 µV, N/A, N/A, 400 µV	700 µV
Current, 3 A, 1 A, & 300 mA ranges	100 µA, 50 µA	100 µA, 50 µA	N/A
Current, 8 A, 6.7 A, 5 A, & 4 A ranges	-	-	400 µA
Programming accuracy: (At 23 °C ±5 °C after 30 min. warm-up. Applies from minimum to maximum programming range at any load.)			
Voltage, 20 V range	0.025% + 1.8 mV	0.025% + 1.8 mV	0.025% + 1.8 mV
Voltage, 15 V & 10 V ranges	-	-	0.025% + 1.8 mV
Voltage, 6 V range	0.025% + 600 µV	0.025% + 600 µV	0.025% + 1.8 mV
Voltage, 600 mV range	0.025% + 200 µV	0.025% + 200 µV	-
Current, 8 A, 6.7 A, 5 A, & 4 A ranges	-	-	0.04% + 1.5 mA
Current, 3 A & 1 A range	0.04% + 300 µA	0.04% + 300 µA	-
Current, 300 mA range	0.03% + 150 µA	-	-
Current, 100 mA range	-	0.03% + 12 µA	-
Current, 10 mA range	-	0.025% + 5 µA	-
Resistance (in 20 V output range)	0.1% + 3 mΩ	-	0.1% + 1 mΩ
Resistance for 15 V & 10 V ranges	-	-	0.1% + 1 mΩ
Resistance (in 6 V output range)	0.1% + 1.5 mΩ	-	0.1% + 1 mΩ
Measurement accuracy: (at 23 °C ±5 °C)			
Voltage, 20 V range	0.025% + 1.2 mV	0.025% + 1.2 mV	0.025% + 1.8 mV
Voltage, 1 V range	0.025% + 75 µV	0.025% + 75 µV	-
Voltage, 100 mV range	0.025% + 50 µV	0.025% + 50 µV	-
Auxiliary Voltage Measurement Input	0.025% + 5 mV	-	0.025% + 5 mV
Current, 8 A range	-	-	0.04% + 1.5 mA
Current, 3 A range	0.03% + 250 µA	0.03% + 250 µA	-
Current, 100 mA range	0.025% + 10 µA	0.025% + 10 µA	0.025% + 10 µA
Current, 1 mA range	0.025% + 100 nA	0.025% + 100 nA	0.025% + 100 nA
Current, 10 µA range	0.025% + 8 nA	0.025% + 8 nA	-
Load transient response time in Voltage Priority mode: Time to recover to within the settling band. With 150 µF cap (ESR=50 mΩ) at load, remote sensing at cap, 4.25' twisted pair load leads - See Service Guide for setup information.			
Rise time (10% to 90%)	10 µs	10 µs	10 µs
Settling band			
20 V range with a 0.8 A load step	± 10 mV	± 10 mV	± 20 mV
15 V & 10 V range with a 1.4 A load step	-	-	± 20 mV
6 V range with a 1.4 A load step	± 20 mV	± 20 mV	± 20 mV
Recovery time	≤ 35 µs	≤ 35 µs	≤ 35 µs

N6781A/82A/84A Performance Specifications, continued

	N6781A, N6782A	N6784A	N6785A, N6786A
Source effect (line regulation)			
Voltage	300 μ V	300 μ V	100 μ V
Current	60 μ A	60 μ A	100 μ A

Supplemental Characteristics

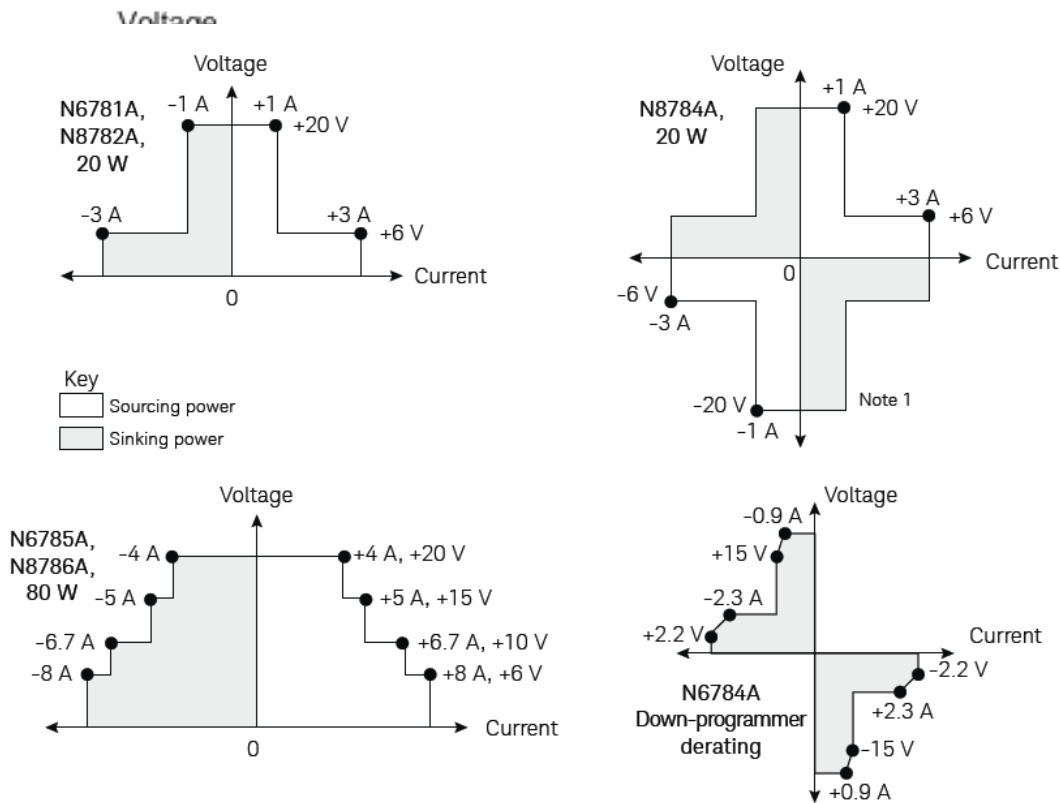

Note 1.

When sinking power, the N6784A model can operate at the maximum rated output power for only a limited amount of time. The unit monitors the temperature of the internal power devices and latches the output off if the output power has exceeded its safe limits. A protect clear is required to resume normal operation. The condition is annunciated by the OT status bit. Refer to the downprogrammer derating figure for the values of the safe limit boundaries.

Unless otherwise noted, specifications are warranted over the ambient temperature range of 0 to 55 °C after a 30-minute warm-up period. Unless otherwise noted, specifications apply at the mainframe output terminals, with each module's sense terminals internally connected to its output terminals (local sensing).

For the setup conditions and all output specifications refer to the Keysight N6705 Service Guide (literature number N6705-90010) (<http://literature.cdn.keysight.com/litweb/pdf/N6700-90001.pdf>)

Supplemental characteristics are not warranted but are descriptions of performance determined either by design or by type testing. All supplemental characteristics are typical unless otherwise noted.



Ordering information

Model Number	Description
N6781A	2-Quadrant Source/Measure Unit for Battery Drain Analysis (20 W)
N6782A	2-Quadrant Source/Measure Unit for Functional Test (20 W)
N6784A	4-Quadrant General Purpose Source/Measure Unit (20 W)
N6785A	2-Quadrant Source/Measure Unit for Battery Drain Analysis (80 W)
N6786A	2-Quadrant Source/Measure Unit for Functional Test (80 W)
N6705B-056	Software License to Control N6705A/B with 14585A Control and Analysis Software (Option to the N6705B when ordered new)
N6705U-056	Upgrade an N6705A/B DC Power Analyzer with 14585A Software License
N6705U-057	Upgrade kit, rear panel only - replaces rear panel of N6705A with that of N6705B
N6705U-058	SMU accessories - output adapter kit for N6705A, cable extensions for N6785A/86A

Web resources

Visit our web sites for additional product information and literature.

N6780 Series SMUs

www.keysight.com/find/N6781

www.keysight.com/find/N6782

www.keysight.com/find/N6784

www.keysight.com/find/N6785

www.keysight.com/find/N6786

14585A Control and Analysis Software

www.keysight.com/find/14585

N6705B DC Power Analyzer

www.keysight.com/find/N6705

N6700 Modular Power System

www.keysight.com/find/N6700

Related literature

Keysight DC Power Analyzer Product Overview, literature number 5989-6319EN

Keysight N6705 DC Power Analyzer User's Guide, literature number N6705-90001

Keysight N6705 DC Power Analyzer Service Guide, literature number N6705-90010

Keysight N6700 MPS Low-Profile Modular Power System Product Overview, literature number 5989-1411EN

Keysight N6700 Series Power Modules Specifications Guide, literature number N6700-90001.

myKeysight

myKeysight

www.keysight.com/find/mykeysight

A personalized view into the information most relevant to you.



www.axiestandard.org

AdvancedTCA® Extensions for Instrumentation and Test (AXIe) is an open standard that extends the AdvancedTCA for general purpose and semiconductor test. Keysight is a founding member of the AXIe consortium. ATCA®, AdvancedTCA®, and the ATCA logo are registered US trademarks of the PCI Industrial Computer Manufacturers Group.



www.lxistandard.org

LAN eXtensions for Instruments puts the power of Ethernet and the Web inside your test systems. Keysight is a founding member of the LXI consortium.



www.pxisa.org

PCI eXtensions for Instrumentation (PXI) modular instrumentation delivers a rugged, PC-based high-performance measurement and automation system.



Three-Year Warranty

www.keysight.com/find/ThreeYearWarranty

Keysight's commitment to superior product quality and lower total cost of ownership. The only test and measurement company with three-year warranty standard on all instruments, worldwide.



Keysight Assurance Plans

www.keysight.com/find/AssurancePlans

Up to five years of protection and no budgetary surprises to ensure your instruments are operating to specification so you can rely on accurate measurements.



www.keysight.com/go/quality

Keysight Technologies, Inc.
DEKRA Certified ISO 9001:2008
Quality Management System

Keysight Channel Partners

www.keysight.com/find/channelpartners

Get the best of both worlds: Keysight's measurement expertise and product breadth, combined with channel partner convenience.

For more information on Keysight Technologies' products, applications or services, please contact your local Keysight office. The complete list is available at: www.keysight.com/find/contactus

Americas

Canada	(877) 894 4414
Brazil	55 11 3351 7010
Mexico	001 800 254 2440
United States	(800) 829 4444

Asia Pacific

Australia	1 800 629 485
China	800 810 0189
Hong Kong	800 938 693
India	0124 229 2010
Japan	0120 (421) 345
Korea	080 769 0800
Malaysia	1 800 888 848
Singapore	1 800 375 8100
Taiwan	0800 047 866
Other AP Countries	(65) 6375 8100

Europe & Middle East

Austria	0800 001122
Belgium	0800 58580
Finland	0800 523252
France	0805 980333
Germany	0800 6270999
Ireland	1800 832700
Israel	1 809 343051
Italy	800 599100
Luxembourg	+32 800 58580
Netherlands	0800 0233200
Russia	8800 5009286
Spain	800 000154
Sweden	0200 882255
Switzerland	0800 805353
	Opt. 1 (DE)
	Opt. 2 (FR)
	Opt. 3 (IT)
United Kingdom	0800 0260637

For other unlisted countries:
www.keysight.com/find/contactus
(BP-02-06-15)

