

WL50S High-Intensity Work Spot Light



Datasheet

General-purpose LED work lighting

For the latest technical information about this product, including specifications, dimensions, and wiring, see www.bannerengineering.com.

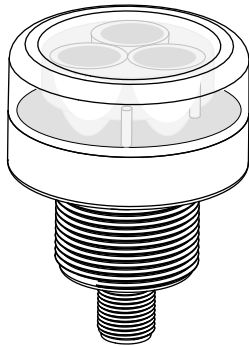

- Three lens options, depending on model, to vary spot size
- Illuminates a large area with an even pattern of light and no shadows
- 12 to 30V dc operation
- Cabled and quick-disconnect models available
- 50 mm diameter with flat profile and 30 mm mounting base
- Rugged sealed housing rated to IP69K



WARNING: Not To Be Used for Personnel Protection

Never use this device as a sensing device for personnel protection. Doing so could lead to serious injury or death. This device does not include the self-checking redundant circuitry necessary to allow its use in personnel safety applications. A sensor failure or malfunction can cause either an energized or de-energized sensor output condition.

Models

Model ¹	LED Color	Lumens	Lux		Lens Angle	Connection
			0.5 m	1 m		
WL50SWL5Q	White, 5000-8300 K	295	13780	3445	±5° (smaller, more focused spot; see graph)	5 pin Euro integral QD connector (use with a 4-wire mating cordset; only 2 wires used for connection)
WL50SRL5Q	Red, 620-630 nm	110	8000	2000		
WL50SGL5Q	Green, 520-535 nm	210	13000	3250		
WL50SWL11Q	White, 5000-8300 K	285	5460	1365	±11° (larger spot; see graph)	
WL50SRL11Q	Red, 620-630 nm	105	2500	625		
WL50SGL11Q	Green, 520-535 nm	200	3900	975		
WL50SWL20Q	White, 5000-8300 K	270	2000	500	±20° (largest spot; see graph)	
WL50SRL20Q	Red, 620-630 nm	100	1040	260		
WL50SGL20Q	Green, 520-535 nm	190	1700	425		

¹ Integral QD models only are listed. For integral 2 m (6.5') PVC cable, omit suffix Q from model number (example, WL50SWL5). A model with a QD requires a mating cordset (see [4-Pin Euro-Style Cordsets](#) on page 3).



Specifications

Supply Voltage and Current

Operating voltage: 12 to 30V dc
Current draw: 400 mA max.

Supply Protection Circuitry

Protected against reverse polarity and transient voltages

Light Source

Three high-intensity LEDs; see models table for color temperature or wavelengths

Useful Life

When operating within specifications, output will decrease less than 30% after 50,000 hours.

Construction

Black anodized aluminum housing; polycarbonate window; nickel-plated QD connector or PVC-jacketed cable; black zinc-plated steel mounting nut

Mounting:

30x1.5 mm thread base mount

Connections

Integral 5-pin M12/Euro style QD or 2 m (6.5 ft) integral cable, depending on model; 4-pin connecting cordset required for QD models; only 2 wires used

Environmental Rating

IEC IP67, IP69K per DIN 40050-9



NOTE: Do not spray the cable with a high-pressure sprayer or cable damage will result.

Operating Conditions

-20 °C to +50 °C (-4 °F to +122 °F)
95% maximum relative humidity (non-condensing)

Vibration and Mechanical Shock

All models meet Mil. Std. 202F requirements method 201A (vibration: 10 to 60 Hz max., double amplitude 0.06", maximum acceleration 10G). Also meets IEC 947-5-2; 30G 11 ms duration, half sine wave.

Storage Temperature

-40 °C to +70 °C (-40 °F to +158 °F)

Certifications



Beam Patterns

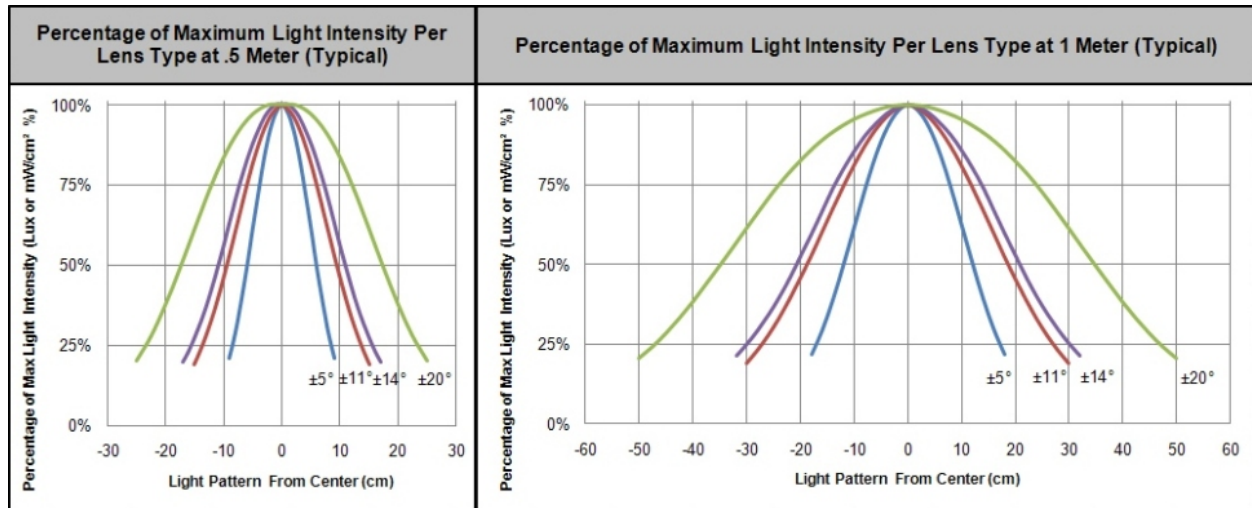

Dimensions

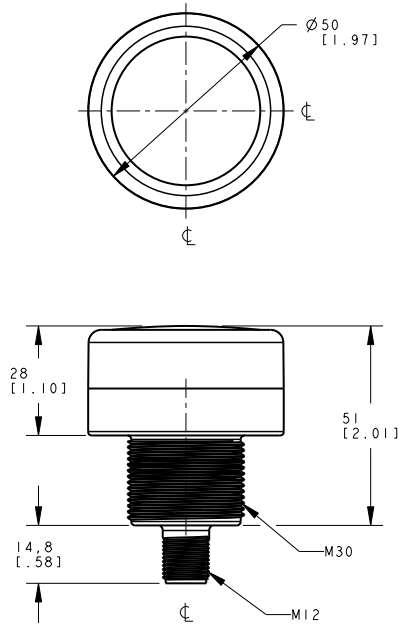

Wiring

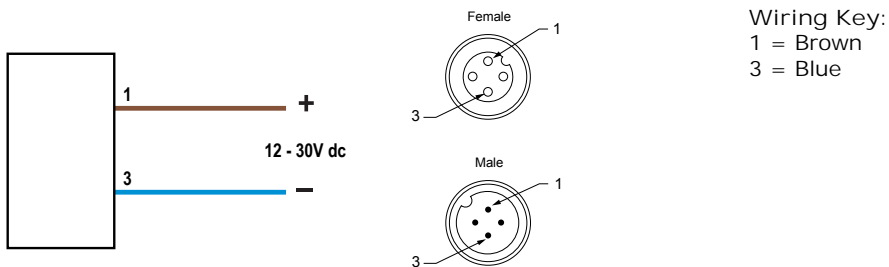

4-Pin Euro-Style Cordsets

4-Pin Threaded M12/Euro-Style Cordsets				
Model	Length	Style	Dimensions	Pinout
MQDC-406	1.83 m (6 ft)	Straight		<p>1 = Brown 2 = White 3 = Blue 4 = Black</p>
MQDC-415	4.57 m (15 ft)			
MQDC-430	9.14 m (30 ft)			
MQDC-450	15.2 m (50 ft)			

4-Pin Threaded M12/Euro-Style Cordsets				
Model	Length	Style	Dimensions	Pinout
MQDC-406RA	1.83 m (6 ft)	Right-Angle		
MQDC-415RA	4.57 m (15 ft)			
MQDC-430RA	9.14 m (30 ft)			
MQDC-450RA	15.2 m (50 ft)			

Mounting Brackets

All measurements are in mm

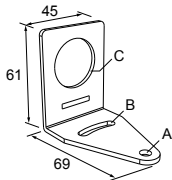
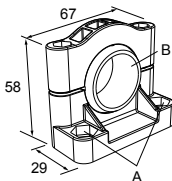
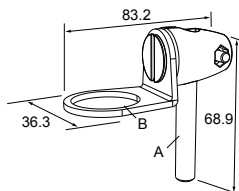
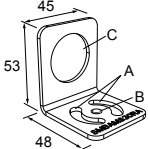
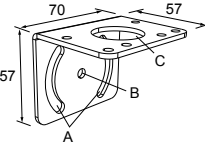
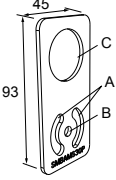
<p>SMB30A</p> <ul style="list-style-type: none"> Right-angle bracket with curved slot for versatile orientation Clearance for M6 (¼ in) hardware Mounting hole for 30 mm sensor 12-ga. stainless steel  <p>Hole center spacing: A to B=40 Hole size: A=ø 6.3, B= 27.1 x 6.3, C=ø 30.5</p>	<p>SMB30SC</p> <ul style="list-style-type: none"> Swivel bracket with 30 mm mounting hole for sensor Black reinforced thermoplastic polyester Stainless steel mounting and swivel locking hardware included  <p>Hole center spacing: A=ø 50.8 Hole size: A=ø 7.0, B=ø 30.0</p>
<p>SMB30FA</p> <ul style="list-style-type: none"> Swivel bracket with tilt and pan movement for precise adjustment Mounting hole for 30 mm sensor 12-ga. 304 stainless steel Easy sensor mounting to extrude rail T-slot Metric and inch size bolt available  <p>Bolt thread: SMB30FA, A= 3/8 - 16 x 2 in; SMB30FAM10, A= M10 - 1.5 x 50 Hole size: B= ø 30.1</p>	<p>SMBAMS30RA</p> <ul style="list-style-type: none"> Right-angle SMBAMS series bracket 30 mm hole for mounting sensors Articulation slots for 90° + rotation 12-ga. (2.6 mm) cold-rolled steel  <p>Hole center spacing: A=26.0, A to B=13.0 Hole size: A=26.8 x 7.0, B=ø 6.5, C=ø 31.0</p>
<p>SMB30MM</p> <ul style="list-style-type: none"> 12-ga. stainless steel bracket with curved mounting slots for versatile orientation Clearance for M6 (¼ in) hardware Mounting hole for 30 mm sensor  <p>Hole center spacing: A = 51, A to B = 25.4 Hole size: A = 42.6 x 7, B = ø 6.4, C = ø 30.1</p>	<p>SMBAMS30P</p> <ul style="list-style-type: none"> Flat SMBAMS series bracket 30 mm hole for mounting sensors Articulation slots for 90° + rotation 12-ga. 300 series stainless steel  <p>Hole center spacing: A=26.0, A to B=13.0 Hole size: A=26.8 x 7.0, B=ø 6.5, C=ø 31.0</p>

Banner Engineering Corp Limited Warranty

Banner Engineering Corp. warrants its products to be free from defects in material and workmanship for one year following the date of shipment. Banner Engineering Corp. will repair or replace, free of charge, any product of its manufacture which, at the time it is returned to the factory, is found to have been defective during the warranty period. This warranty does not cover damage or liability for misuse, abuse, or the improper application or installation of the Banner product.

THIS LIMITED WARRANTY IS EXCLUSIVE AND IN LIEU OF ALL OTHER WARRANTIES WHETHER EXPRESS OR IMPLIED (INCLUDING, WITHOUT LIMITATION, ANY WARRANTY OF MERCHANTABILITY OR FITNESS FOR A PARTICULAR PURPOSE), AND WHETHER ARISING UNDER COURSE OF PERFORMANCE, COURSE OF DEALING OR TRADE USAGE.

This Warranty is exclusive and limited to repair or, at the discretion of Banner Engineering Corp., replacement. IN NO EVENT SHALL BANNER ENGINEERING CORP. BE LIABLE TO BUYER OR ANY OTHER PERSON OR ENTITY FOR ANY EXTRA COSTS, EXPENSES, LOSSES, LOSS OF PROFITS, OR ANY INCIDENTAL, CONSEQUENTIAL OR SPECIAL DAMAGES RESULTING FROM ANY PRODUCT DEFECT OR FROM THE USE OR INABILITY TO USE THE PRODUCT, WHETHER ARISING IN CONTRACT OR WARRANTY, STATUTE, TORT, STRICT LIABILITY, NEGLIGENCE, OR OTHERWISE.

Banner Engineering Corp. reserves the right to change, modify or improve the design of the product without assuming any obligations or liabilities relating to any product previously manufactured by Banner Engineering Corp.