

Dual IGBTMOD™ A-Series Module 300 Amperes/1700 Volts

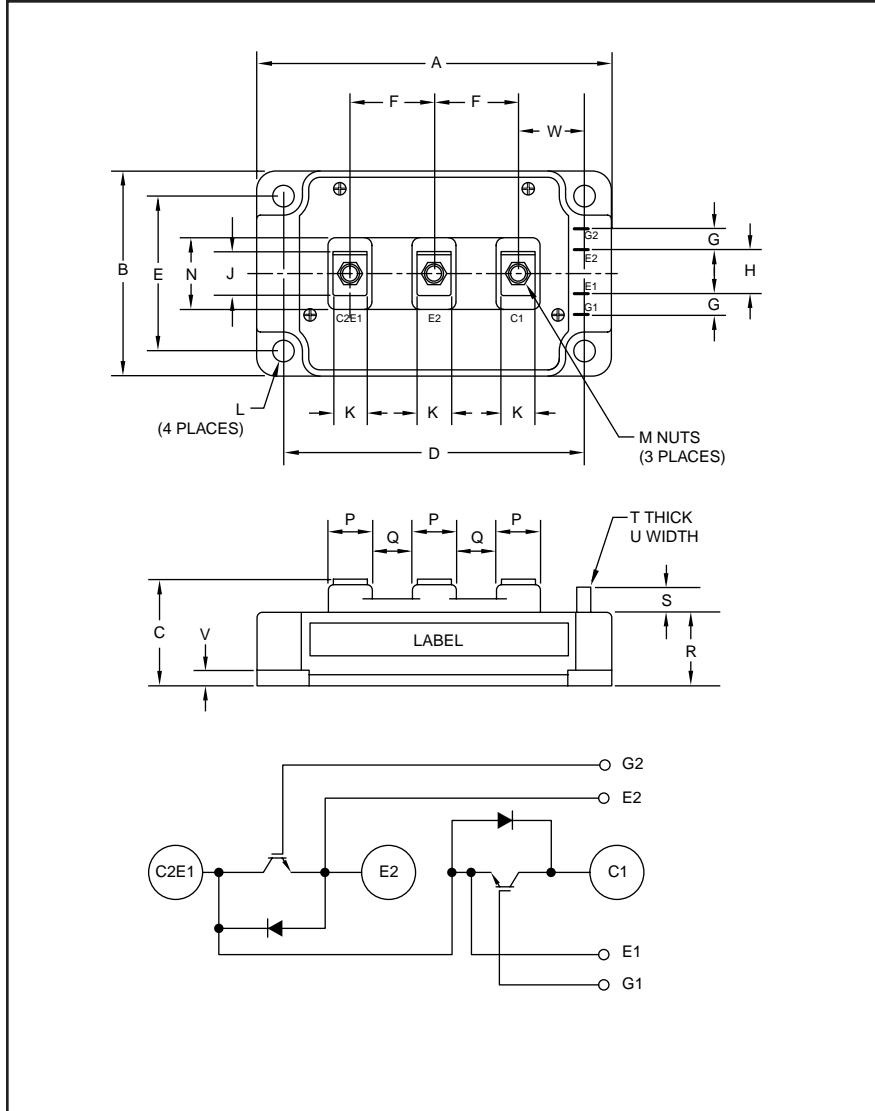

Outline Drawing and Circuit Diagram

Dimensions	Inches	Millimeters
A	4.33	110.0
B	3.15	80.0
C	1.14+0.04/-0.02	29.0+1.0/-0.5
D	3.66±0.01	93.0±0.25
E	2.44±0.01	62.0±0.25
F	0.98	25.0
G	0.24	6.0
H	0.59	15.0
J	0.81	20.5
K	0.55	14.0
L	0.26 Dia.	Dia. 6.5

Dimensions	Inches	Millimeters
M	M6 Metric	M6
N	1.18	30.0
P	0.71	18.0
Q	0.28	7.0
R	0.83	21.2
S	0.33	8.5
T	0.02	0.5
U	0.110	2.8
V	0.16	4.0
W	0.85	21.5

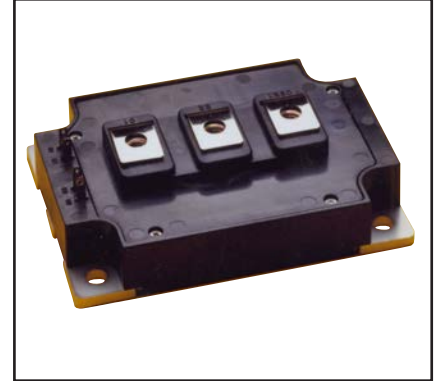

Description:

Powerex IGBTMOD™ Modules are designed for use in switching applications. Each module consists of two IGBT Transistors in a half-bridge configuration with each transistor having a reverse-connected super-fast recovery free-wheel diode. All components and interconnects are isolated from the heat sinking baseplate, offering simplified system assembly and thermal management.

Features:

- Low Drive Power
- Low $V_{CE(sat)}$
- Discrete Super-Fast Recovery Free-Wheel Diode
- Isolated Baseplate for Easy Heat Sinking

Applications:

- AC Motor Control
- UPS
- Battery Powered Supplies

Ordering Information:

Example: Select the complete part module number you desire from the table below -i.e. CM300DY-34A is a 1700V (V_{CES}), 300 Ampere Dual IGBTMOD™ Power Module.

Type	Current Rating Amperes	V_{CES} Volts (x 50)
CM	300	34



Powerex, Inc., 173 Pavilion Lane, Youngwood, Pennsylvania 15697 (724) 925-7272 www.pwr.com

CM300DY-34A
Dual IGBTMOD™ A-Series Module
 300 Amperes/1700 Volts

Absolute Maximum Ratings, $T_j = 25^\circ\text{C}$ unless otherwise specified

Ratings	Symbol	CM300DY-34A	Units
Junction Temperature	T_j	-40 to 150	$^\circ\text{C}$
Storage Temperature	T_{stg}	-40 to 125	$^\circ\text{C}$
Collector-Emitter Voltage (G-E Short)	V_{CES}	1700	Volts
Gate-Emitter Voltage (C-E Short)	V_{GES}	± 20	Volts
Collector Current (DC, $T_C = 108^\circ\text{C}$)*4	I_C	300	Amperes
Peak Collector Current (Pulse Repetition)*2	I_{CM}	600	Amperes
Maximum Collector Dissipation ($T_C = 25^\circ\text{C}$, $T_j \leq 150^\circ\text{C}$)*2,*4	P_C	2900	Watts
Emitter Current ($T_C = 25^\circ\text{C}$)	I_E^{*1}	300	Amperes
Peak Emitter Current (Pulse Repetition)*2	I_{EM}^{*1}	600	Amperes
Mounting Torque, M5 Main Terminal	—	30	in-lb
Mounting Torque, M6 Mounting	—	40	in-lb
Weight	—	580	Grams
Isolation Voltage (Main Terminal to Baseplate, $f = 60\text{Hz}$, AC 1 min.)	V_{ISO}	3500	Volts

Static Electrical Characteristics, $T_j = 25^\circ\text{C}$ unless otherwise specified

Characteristics	Symbol	Test Conditions	Min.	Typ.	Max.	Units
Collector-Cutoff Current	I_{CES}	$V_{CE} = V_{CES}$, $V_{GE} = 0\text{V}$	—	—	1.0	mA
Gate Leakage Current	I_{GES}	$V_{GE} = V_{GES}$, $V_{CE} = 0\text{V}$	—	—	2.0	μA
Gate-Emitter Threshold Voltage	$V_{GE(th)}$	$I_C = 30\text{mA}$, $V_{CE} = 10\text{V}$	5.5	7.0	8.5	Volts
Collector-Emitter Saturation Voltage	$V_{CE(sat)}$	$I_C = 300\text{A}$, $V_{GE} = 15\text{V}$, $T_j = 25^\circ\text{C}^{*3}$	—	2.2	2.8	Volts
		$I_C = 300\text{A}$, $V_{GE} = 15\text{V}$, $T_j = 125^\circ\text{C}^{*3}$	—	2.45	—	Volts
Total Gate Charge	Q_G	$V_{CC} = 1000\text{V}$, $I_C = 300\text{A}$, $V_{GE} = 15\text{V}$	—	2000	—	nC
Emitter-Collector Voltage	V_{EC}^{*1}	$I_E = 300\text{A}$, $V_{GE} = 0\text{V}^{*3}$	—	—	3.0	Volts

Dynamic Electrical Characteristics, $T_j = 25^\circ\text{C}$ unless otherwise specified

Characteristics	Symbol	Test Conditions	Min.	Typ.	Max.	Units
Input Capacitance	C_{ies}		—	—	74.0	nf
Output Capacitance	C_{oes}	$V_{CE} = 10\text{V}$, $V_{GE} = 0\text{V}$	—	—	8.4	nf
Reverse Transfer Capacitance	C_{res}		—	—	1.6	nf
Inductive	Turn-on Delay Time	$t_{d(on)}$	—	—	950	ns
	Rise Time	t_r	—	—	300	ns
Switch	Turn-off Delay Time	$t_{d(off)}$	—	—	1000	ns
	Fall Time	t_f	—	—	350	ns
Diode Reverse Recovery Time	t_{rr}^{*1}	Switching Operation,	—	—	450	ns
Diode Reverse Recovery Charge	Q_{rr}^{*1}	$I_E = 300\text{A}$	—	30	—	μC

*1 Represents characteristics of the anti-parallel, emitter-to-collector free-wheel diode (FWDI).

*2 Pulse width and repetition rate should be such that device junction temperature (T_j) does not exceed $T_{j(max)}$ rating.

*3 Pulse width and repetition rate should be such as to cause negligible temperature rise.

*4 Case temperature (T_C), and heatsink temperature (T_f) measured point is just under the chips.

CM300DY-34A
Dual IGBTMOD™ A-Series Module
 300 Amperes/1700 Volts

Thermal and Mechanical Characteristics, $T_j = 25^\circ\text{C}$ unless otherwise specified

Characteristics	Symbol	Test Conditions	Min.	Typ.	Max.	Units
Thermal Resistance, Junction to Case	$R_{th(j-c)Q}$	Per IGBT*4	—	—	0.043	$^\circ\text{C/W}$
Thermal Resistance, Junction to Case	$R_{th(j-c)D}$	Per FWDi*4	—	—	0.072	$^\circ\text{C/W}$
Contact Thermal Resistance	$R_{th(c-f)}$	Thermal Grease Applied*4,*5	—	—	—	$^\circ\text{C/W}$
External Gate Resistance	R_G		1.6	—	16	Ω

*4 Case temperature (T_C), and heatsink temperature (T_f) measured point is just under the chips.

*5 Typical value is measured by using thermally conductive grease of $\lambda = 0.9$ [W/(m • K)].

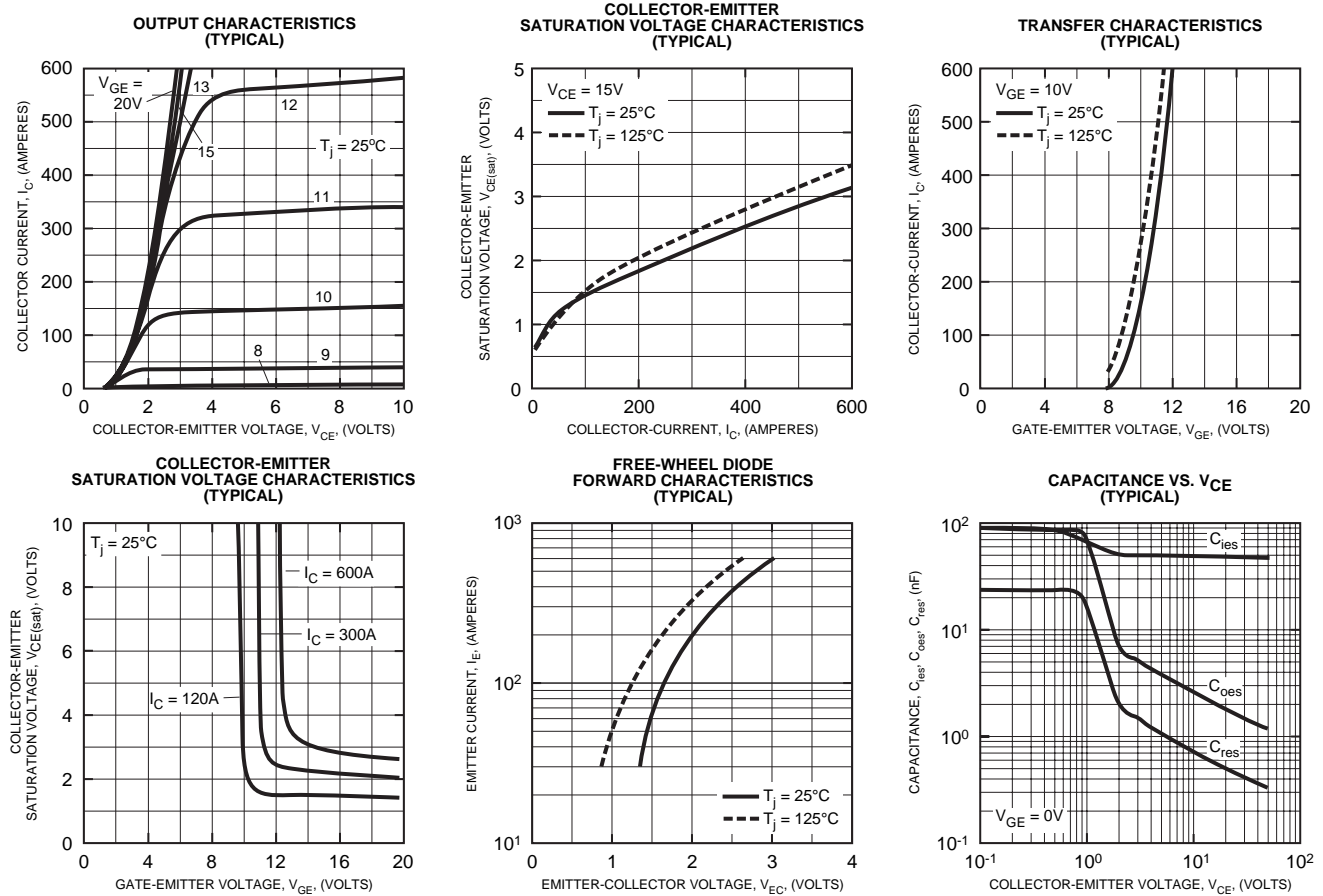

CM300DY-34A
Dual IGBTMOD™ A-Series Module
 300 Amperes/1700 Volts

