

(2,00 mm) .0787"

ESQT (-368), PTHF SERIES

PC/104-PLUS™ SELF-NESTING SOCKETS

SPECIFICATIONS

For complete specifications and recommended PCB layouts see www.samtec.com?ESQT or www.samtec.com?PTHF

Insulator Material:

Black Liquid Crystal Polymer (ESQT)
Black High Temp Nylon (PTHF)

Contact Material:

Phosphor Bronze

Plating:

Au or Sn over 50µ" (1,27 µm) Ni

Operating Temp Range:

-55°C to +125°C

Contact Resistance:

10 mΩ

Insertion Depth:

(2,62 mm) .103" to

(5,03 mm) .198"

Insertion Force:

(Single contact only)

4 oz (1,11 N) average

Normal Force:

60 grams (0,59 N) average

Withdrawal Force:

(Single contact only)

3 oz (0,83 N) average

Max Cycles:

100 with 10µ" (0,25 µm) Au

RoHS Compliant:

Yes

Lead-Free Solderable:

Yes (ESQT)

Mates with:
ESQT, PTHF

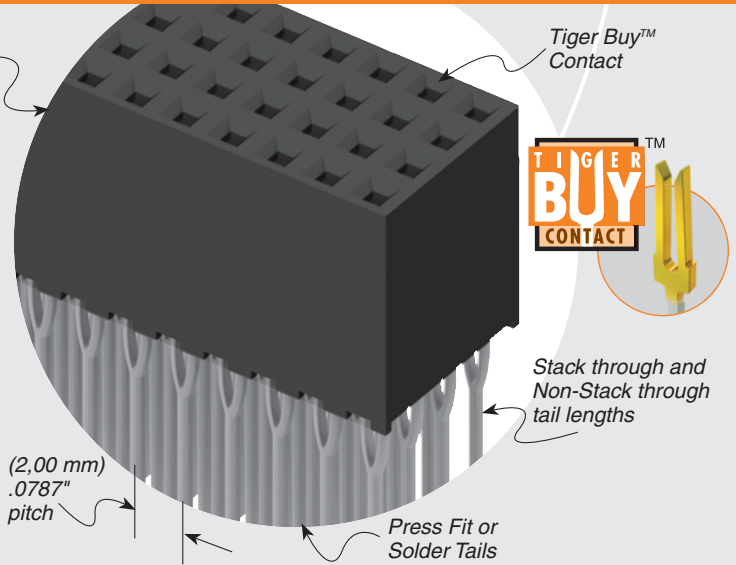
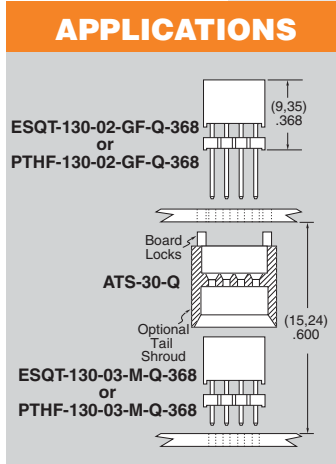

TYPE STRIP	1	NO. PINS PER ROW	30	LEAD STYLE	PLATING OPTION	Q	368
ESQT = Solder Tails				Specify LEAD STYLE from chart	-GF = 15µ" (0,38 µm) Gold on contact, Gold flash on tail (-02 Lead Style only)		
PTHF = Press Fit Tails					-M = 20µ" (0,51 µm) Gold on contact, Matte Tin on tail (-03 Lead Style only)		

LEAD STYLE	ESQT		PTHF	
	A	B	A	B
-02	(21,59) .850	(12,24) .482	(21,59) .850	(12,24) .482
-03	(11,63) .458	(2,29) .090	(12,34) .486	(3,00) .118

RECOGNITIONS

For complete scope of recognitions see www.samtec.com/quality



TOOLING

- Press fit tooling
- Contact Samtec.

OTHER SOLUTIONS

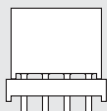

Paste In Hole (PIH) processing. Contact Samtec ASP Group. (Not recommended for stack through applications) ESQT only.

Note: Some lengths, styles and options are non-standard, non-returnable.

ALSO AVAILABLE (MOQ Required)

- Other platings
- Contact Samtec.

